

**UTILITY FENCE DETAILS** N.T.S. **14**

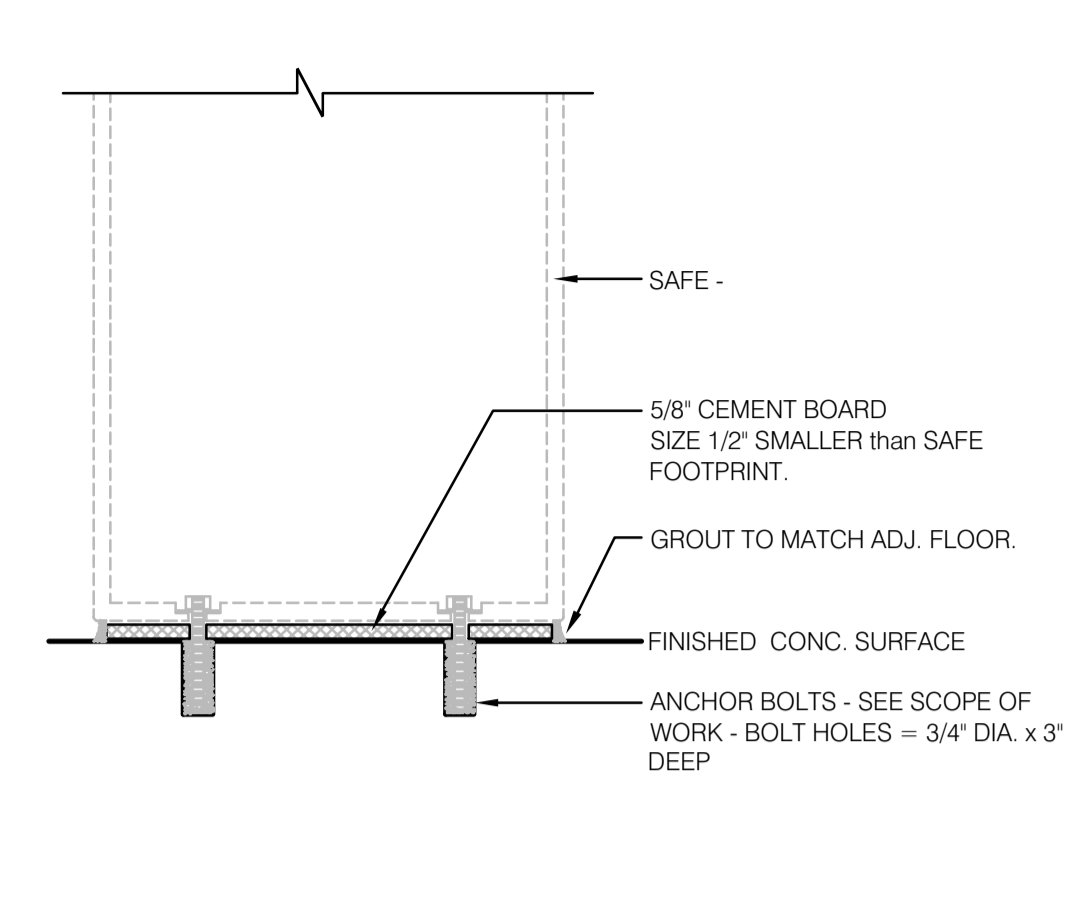

**SAFE PEDESTAL** 1-1/2" = 1'-0" **9**

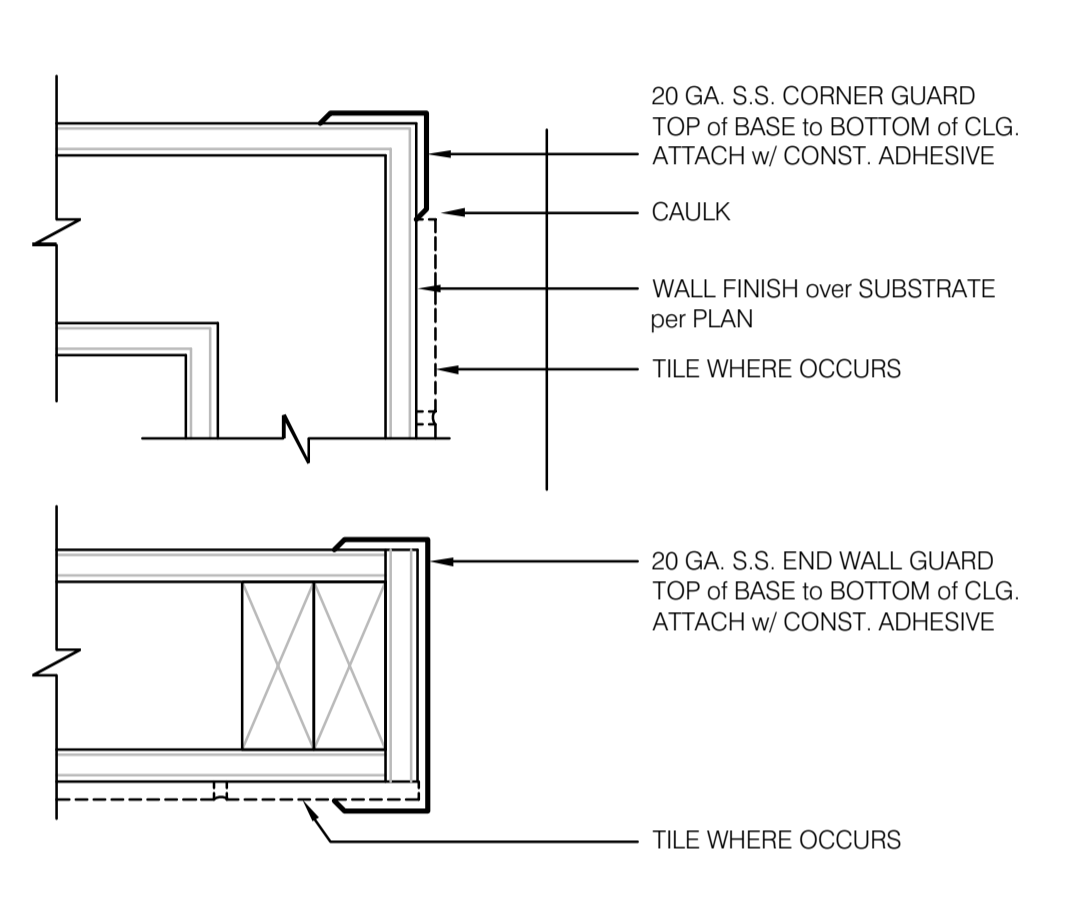

**CORNER GUARD** 3" = 1'-0" **10**

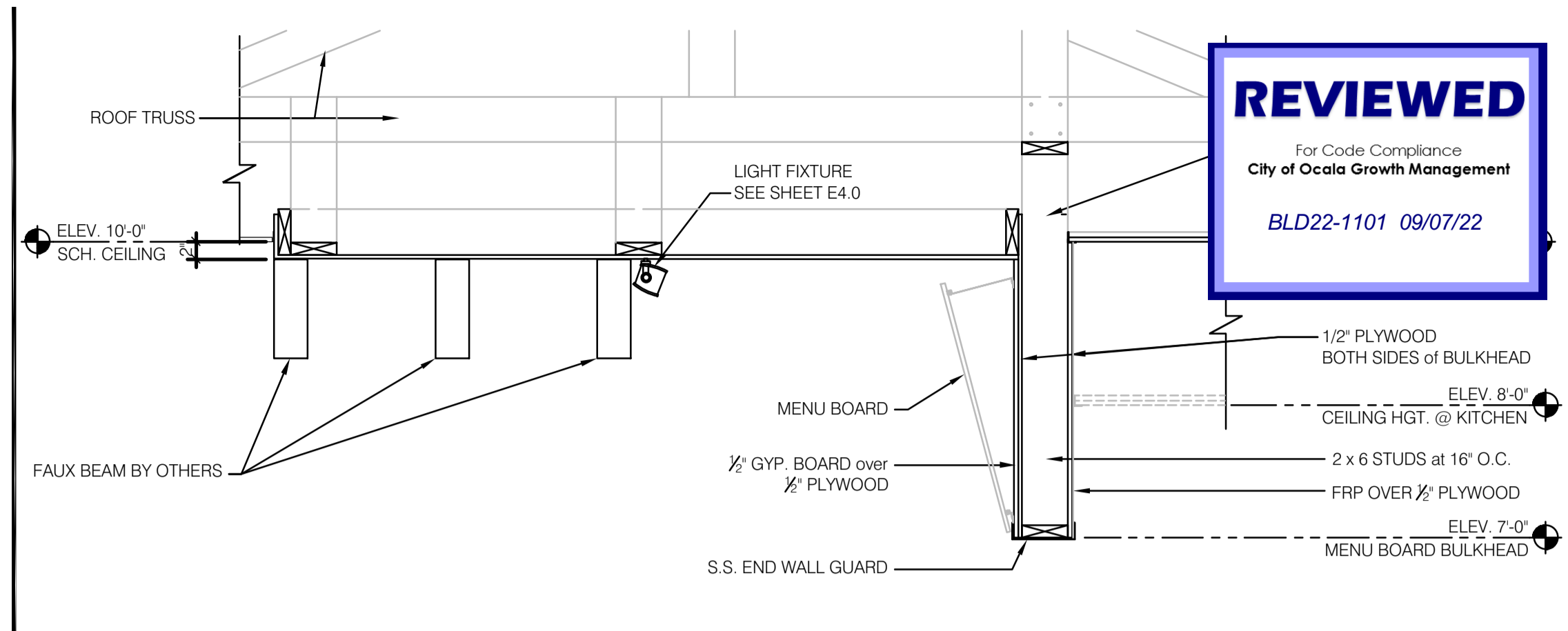

**REVIEWED**

For Code Compliance  
City of Ocala Growth Management

BLD22-1101 09/07/22

**SECTION at MENU BOARD** 3/4" = 1'-0" **1**

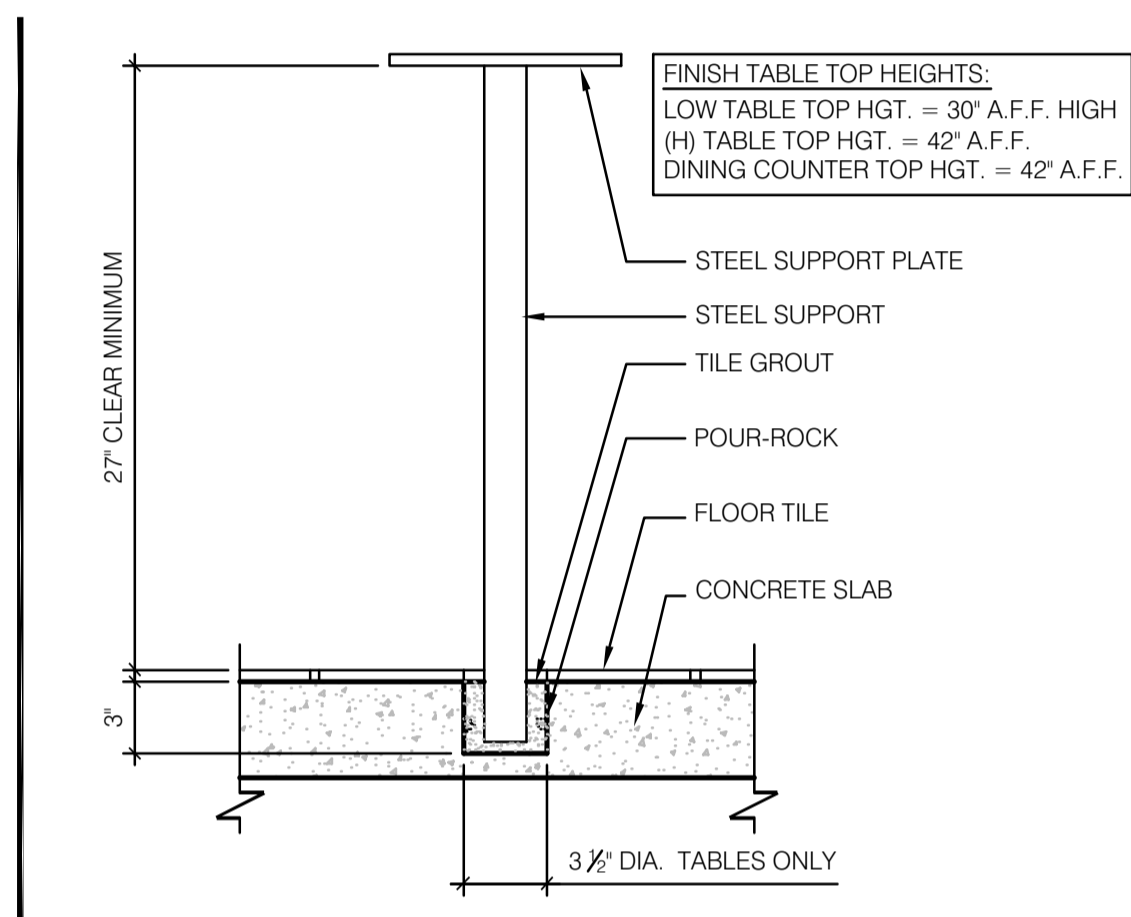

**CORE DRILL** 1-1/2" = 1'-0" **6**

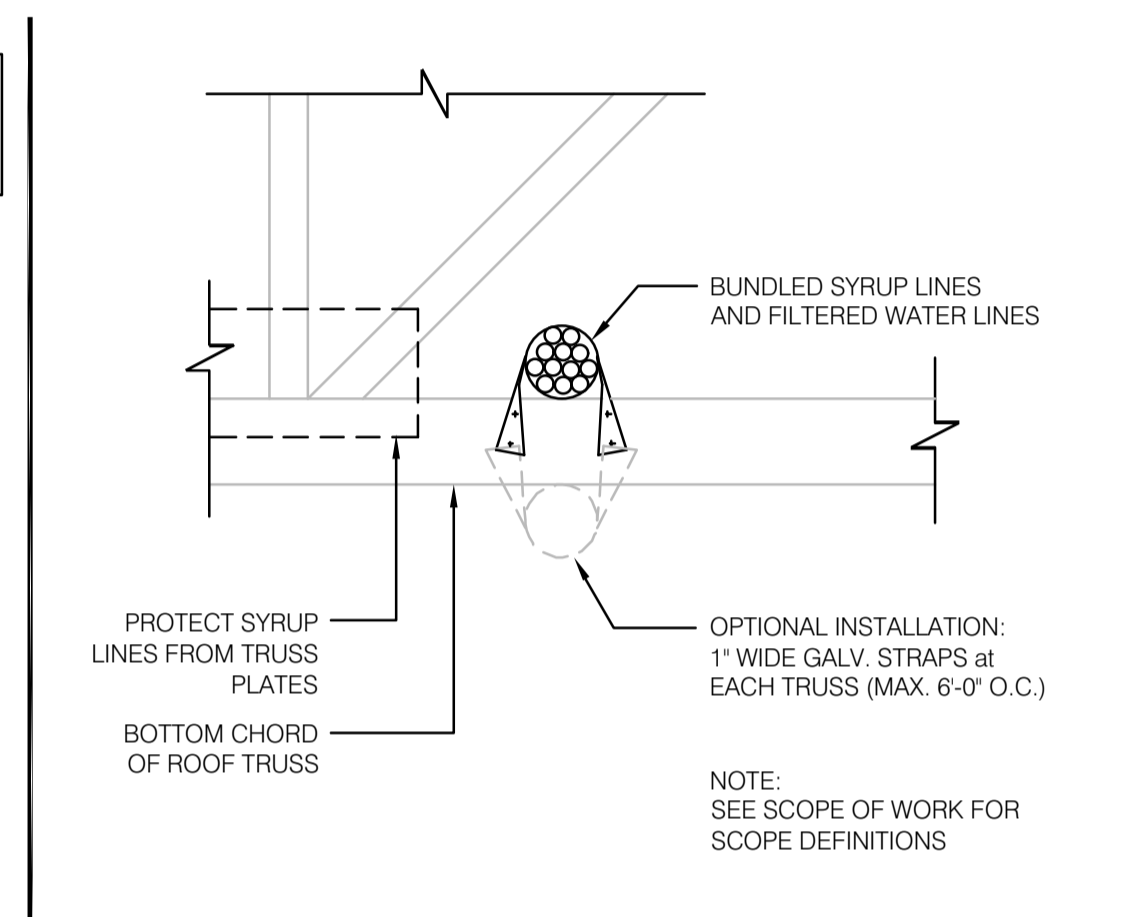

**SYRUP LINE IN CEILING** N.T.S. **2**

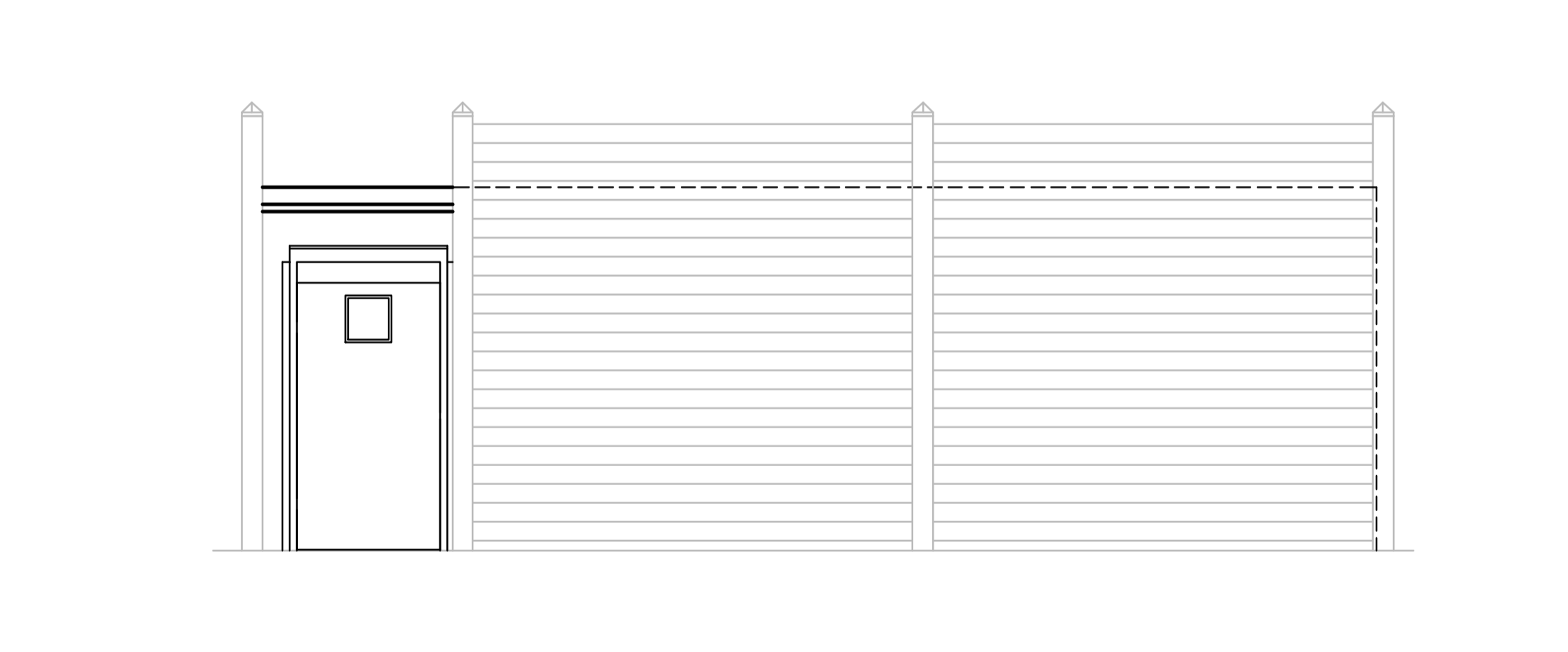

**ENLARGED FENCE ELEVATION** N.T.S. **15**

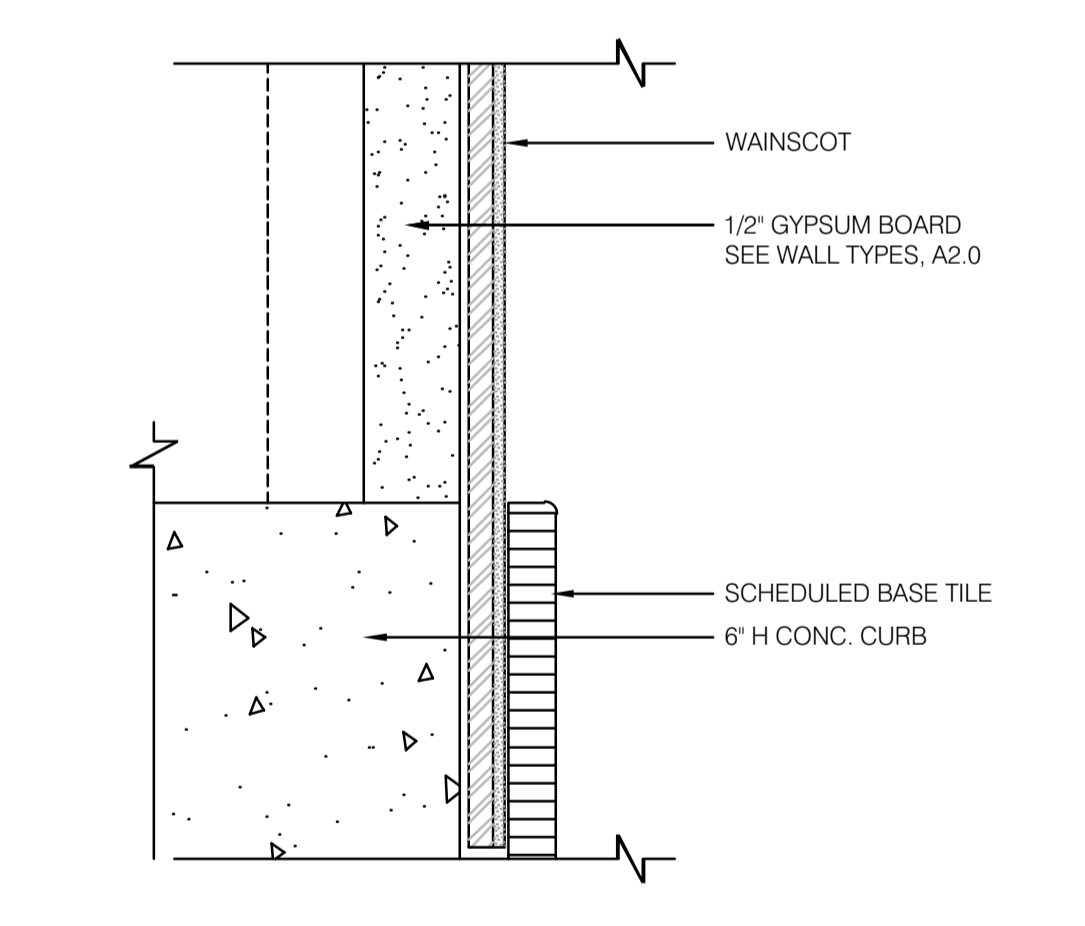

**WC TRIM TERMINATION @ BASE** N.T.S. **11**

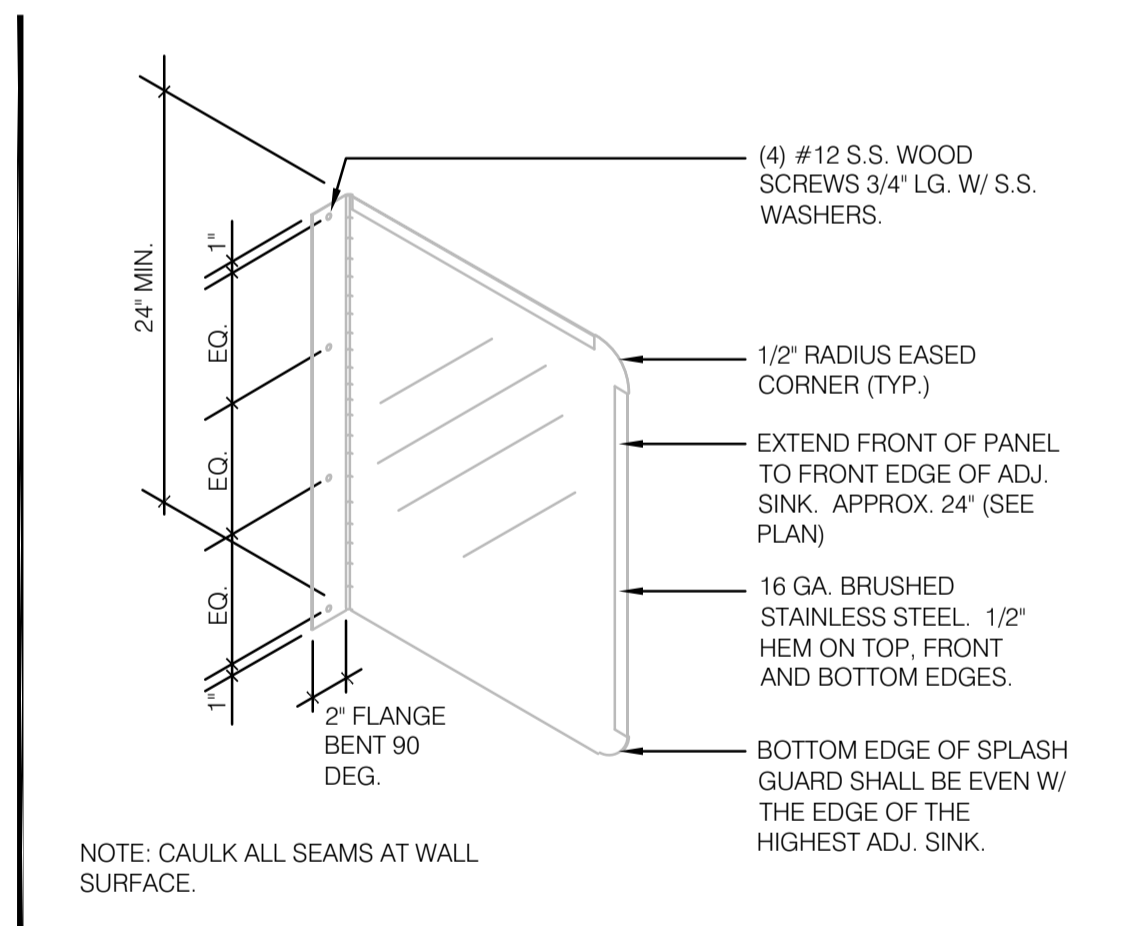

**SPLASH GUARD** N.T.S. **7**

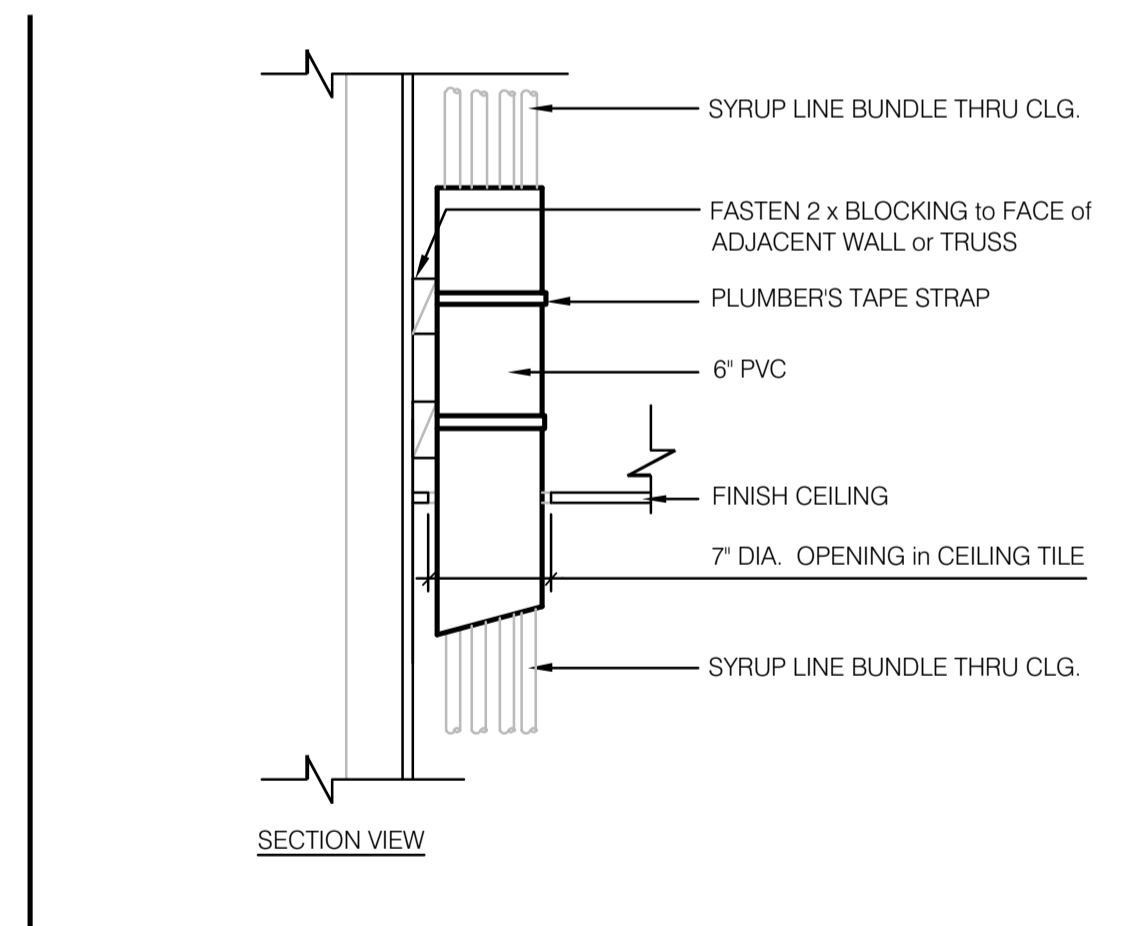

**SYRUP BUNDLE CLG. PENETRATION** N.T.S. **3**

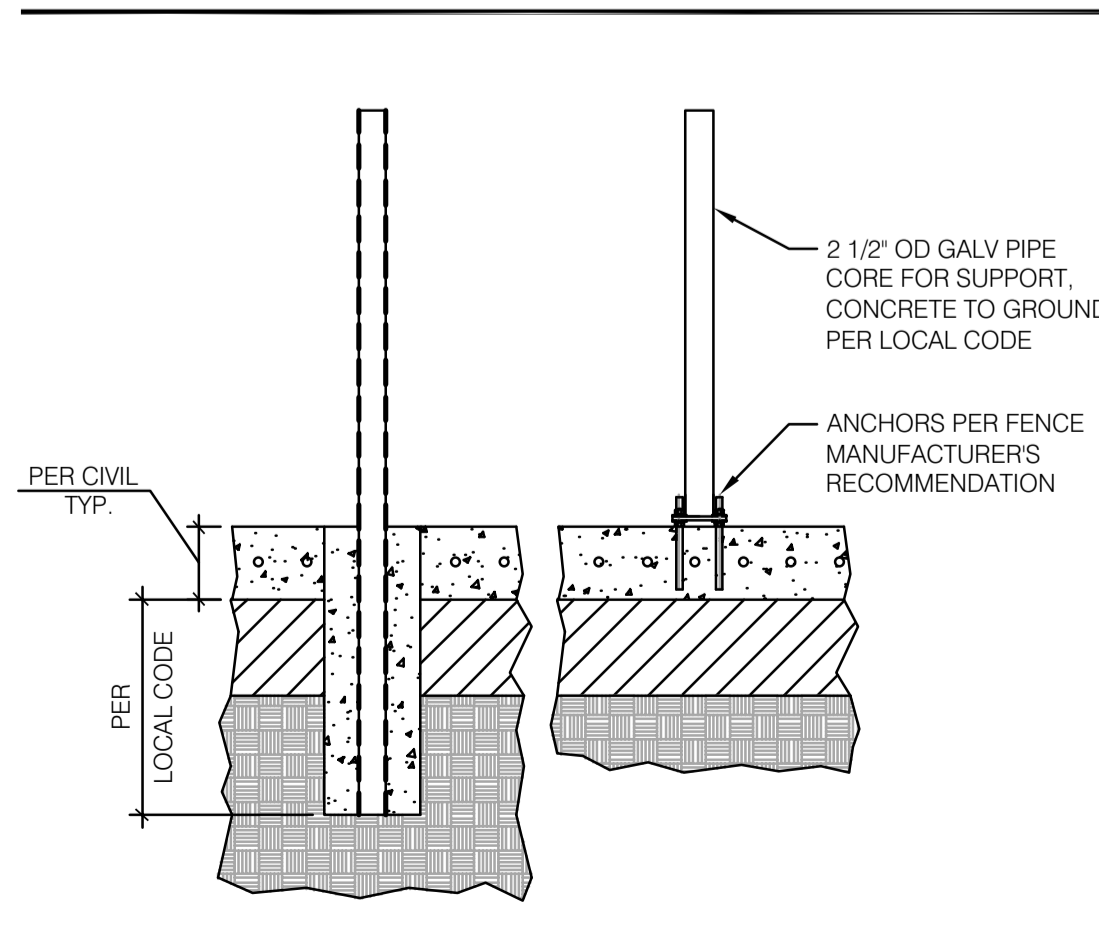

**FENCE FOUNDATION DETAILS** N.T.S. **20**

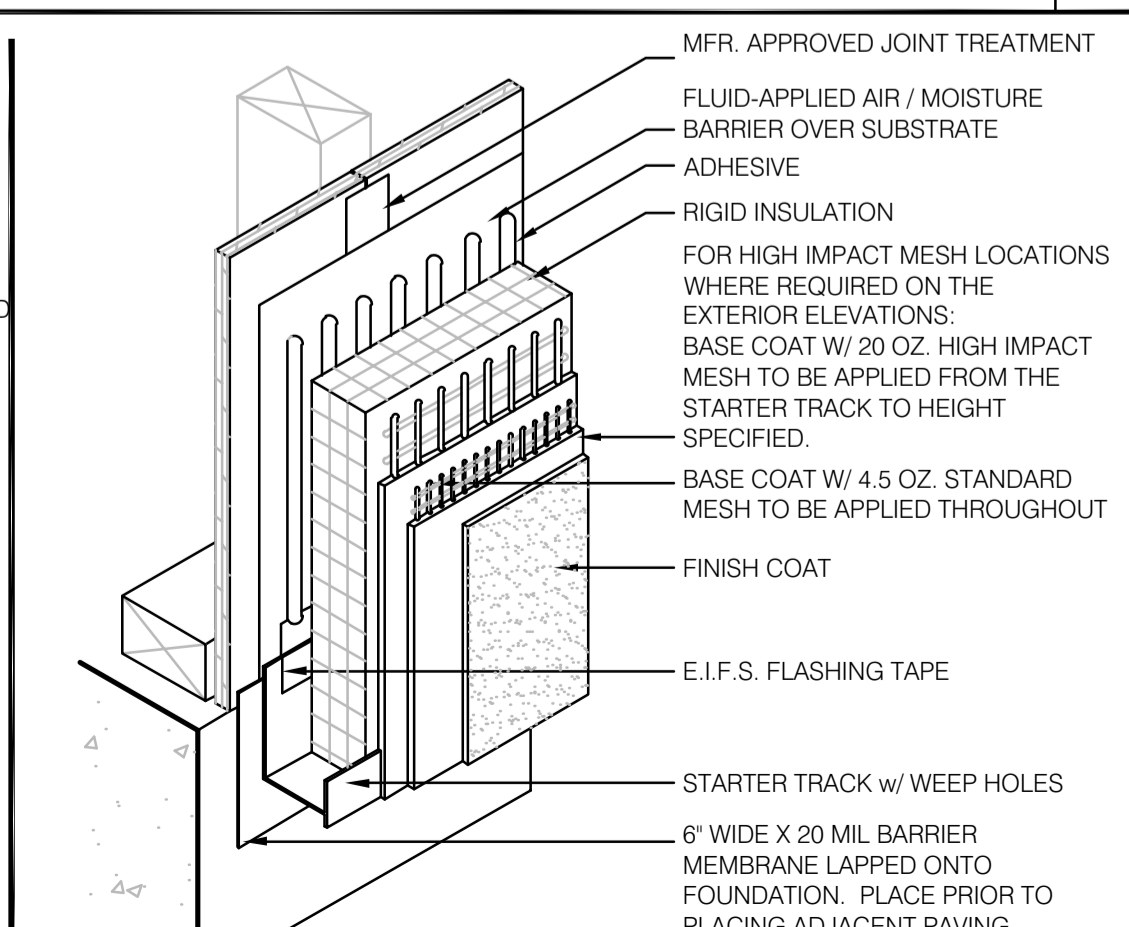

**TYP. E.I.F.S. BASE TERMINATION** N.T.S. **16**

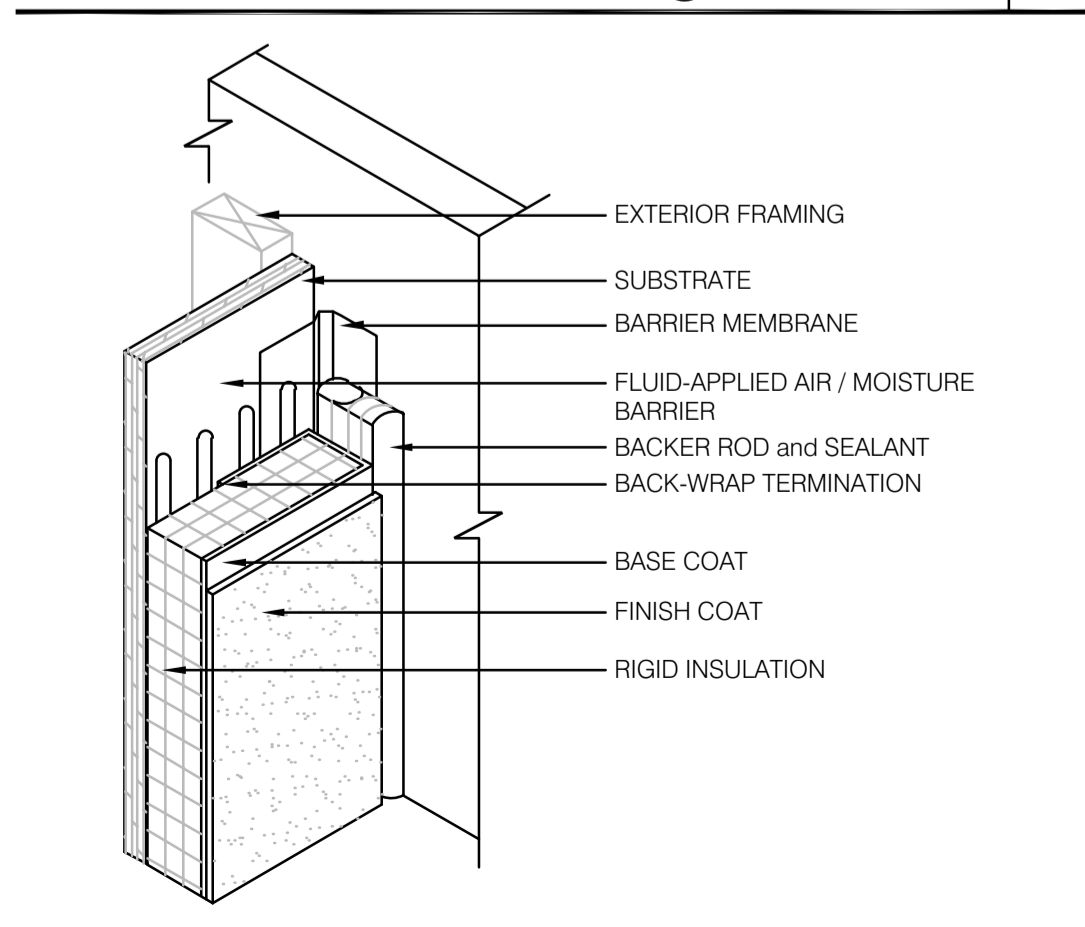

**TYP. E.I.F.S. @ INSIDE CORNER** N.T.S. **12**

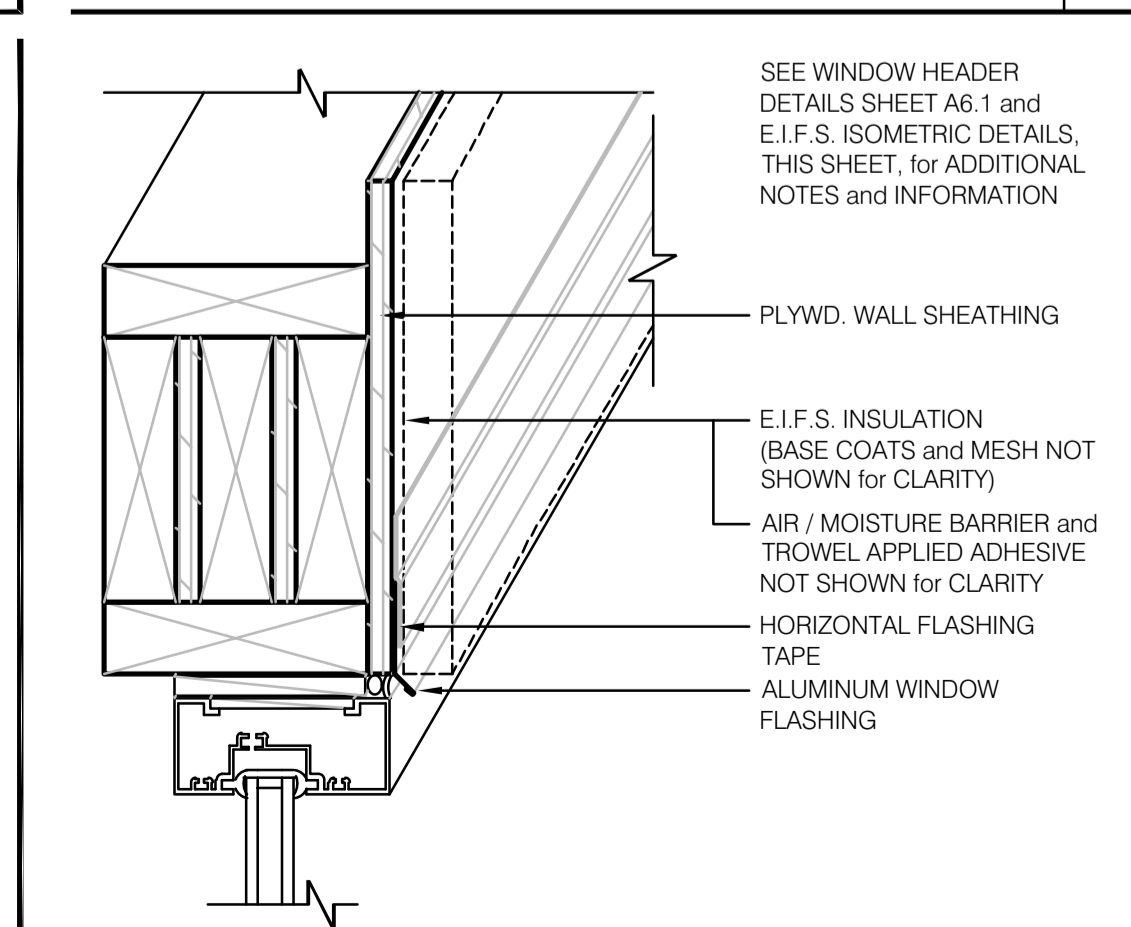

**TYP. E.I.F.S. FLASHING TAPE** N.T.S. **8**

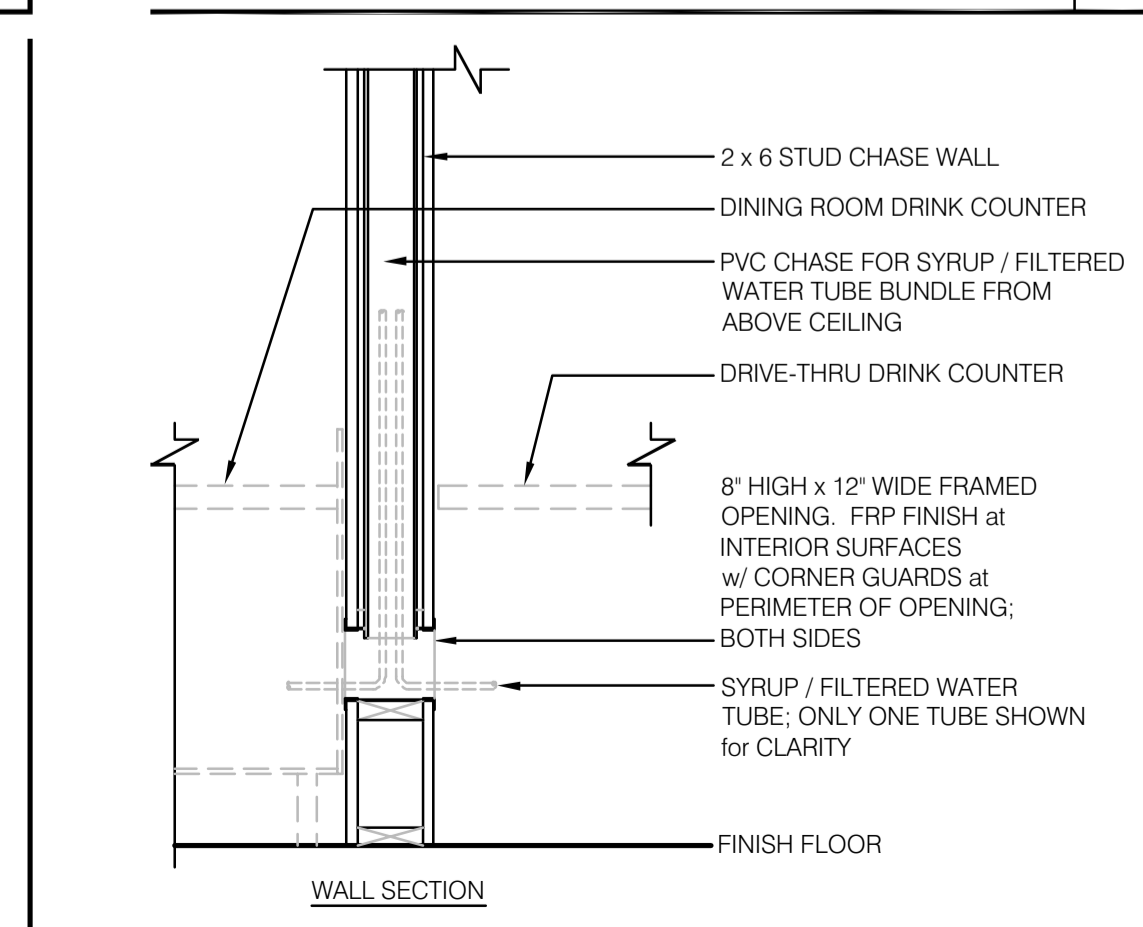

**SYRUP CHASE IN WALL** N.T.S. **4**

ARCHITECTURE ENGINEERING

**LIS**

ARCHITECTURE ENGINEERING OFFICE  
2572 West State Road 426  
Suite 2064, Ocala, FL 32765  
Phone: (321) 244-0402  
facsimile: (321) 244-9419

LAND INVESTMENT SERVICES, LLC  
AA 2602040 CA NO: 6853 LP1057

ENGINEERING OFFICE  
21430 Palm Beach Blvd.  
Avala, Fla. 33920  
Phone: (239) 693-9244  
facsimile: (239) 693-9828



Digitally signed by Harold Hutter  
DN: c=US, o=Unaffiliated,  
ou=A01410C00001734EB2BCFF  
00000303, cn=Harold Hutter  
Date: 2022.03.31 15:21:47 -04'00'

HAROLD DANIEL HUTTER III  
FL. REG. AR98913

PLAN SET REVISIONS:

CONTRACT DATE: ...2019

BUILDING TYPE: Kb 30-19

PLAN VERSION: 2018.A

SITE NUMBER:

ENTITY NUMBER:

STORE NUMBER:

LIS PROJECT: 2019-304

**KFC**

3615 W SILVER SPRINGS BLVD.  
OCALA, FL

Kb 30-19

**CONSTRUCTION  
DETAILS  
INTERIOR  
FINISH**

**A6.3**

PLOT DATE: 03/29/2022