

**BLOCKING DETAIL** 3' = 1'-0" **17**

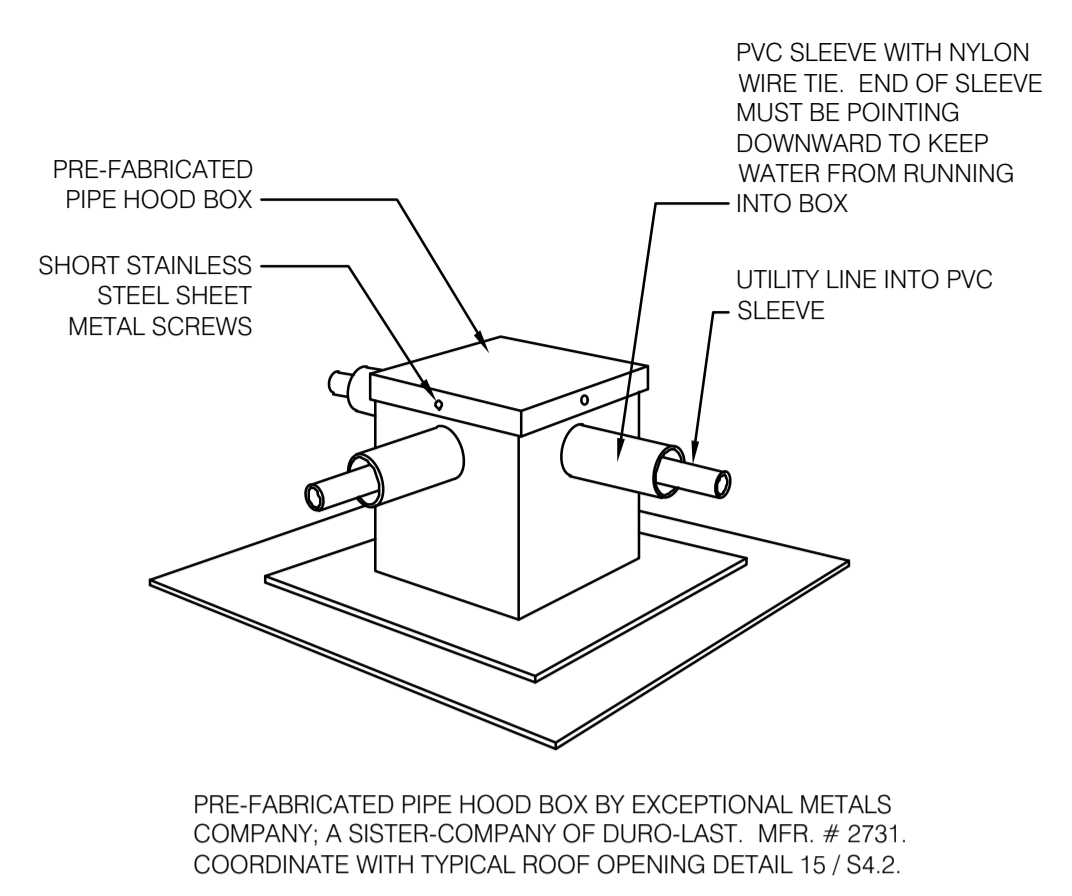

**PIPE HOOD DETAIL** NTS **9**

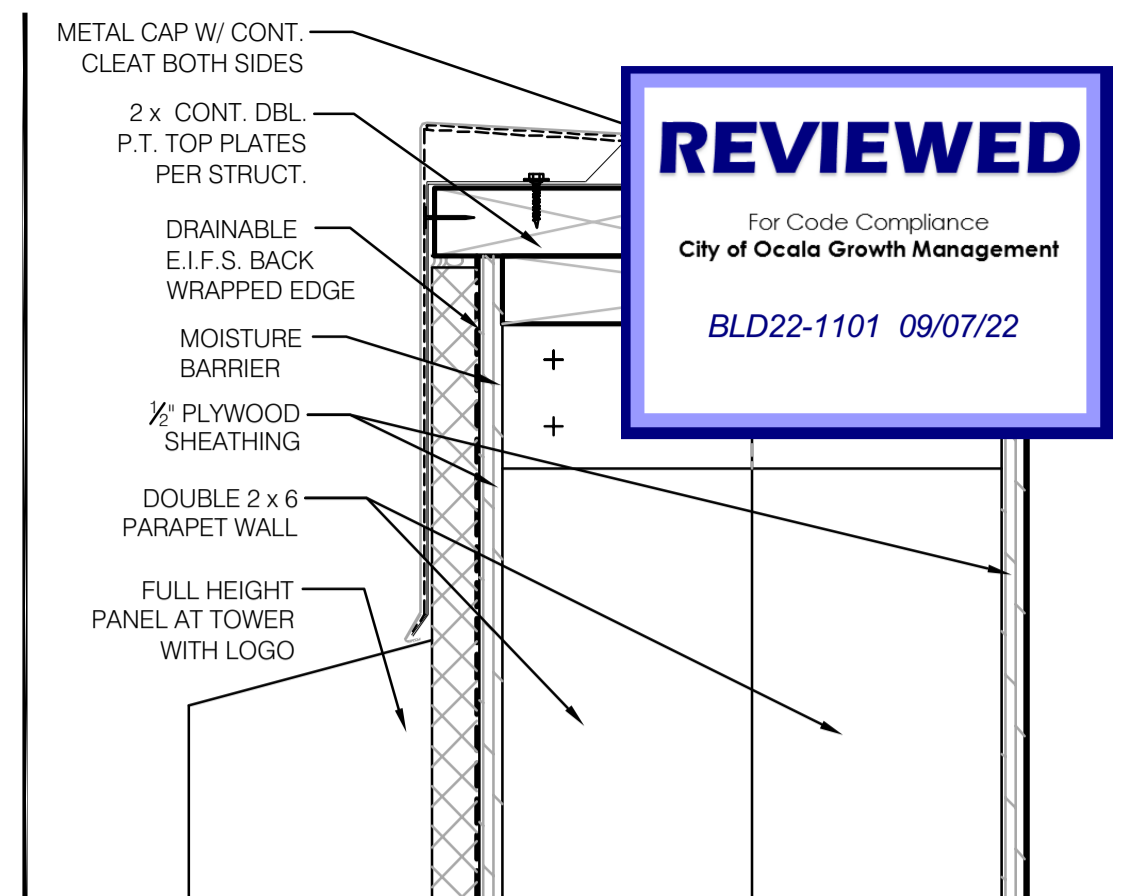

**PARAPET COPING AT TOWER** 3' = 1'-0" **1**

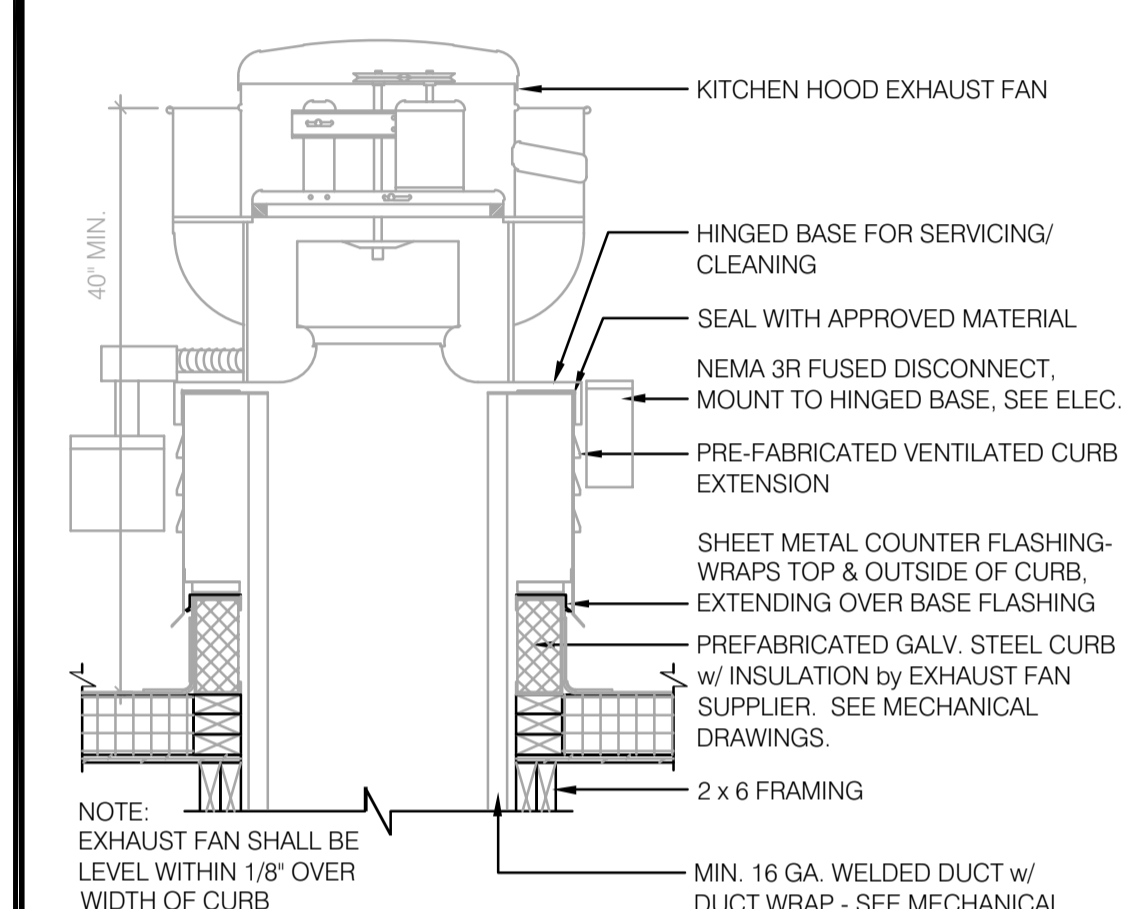

**CURB for EXHAUST FANS EF-1 / EF-2** N.T.S. **18**

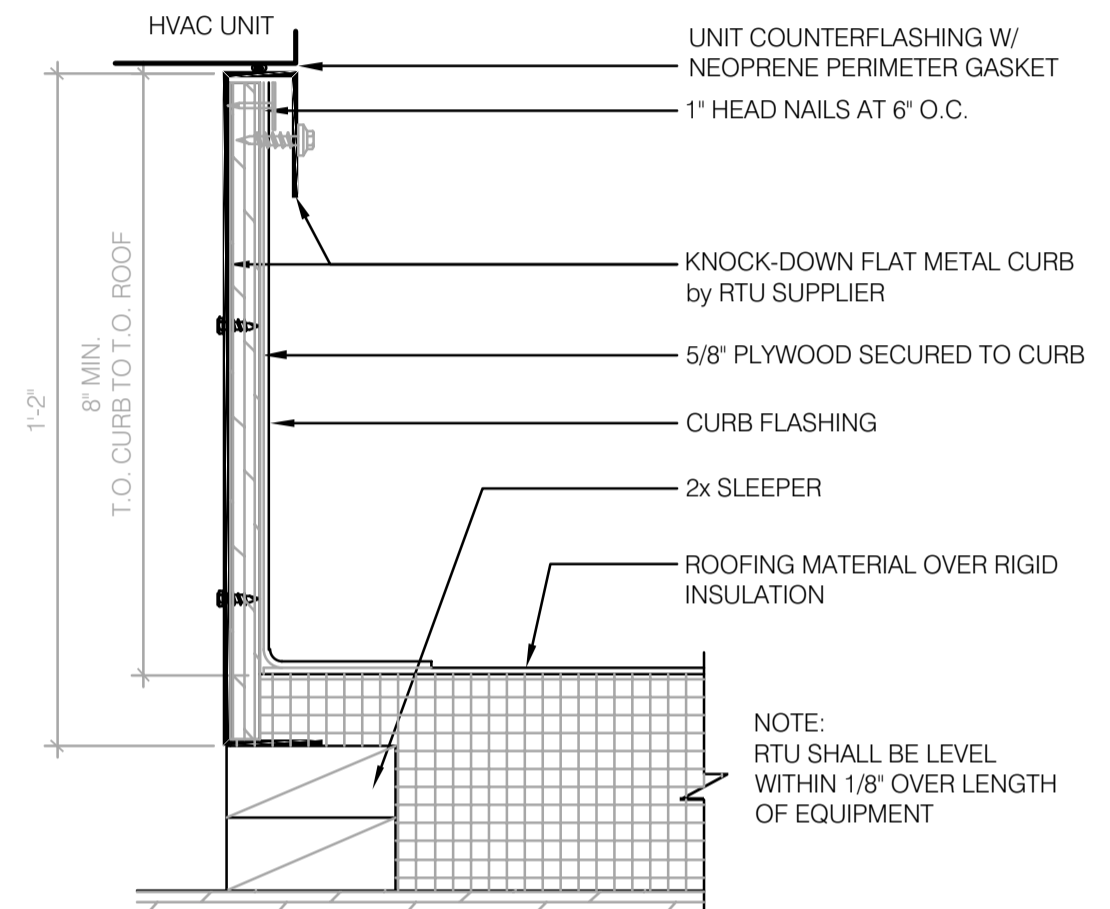

**HVAC CURB** 3' = 1'-0" **14**

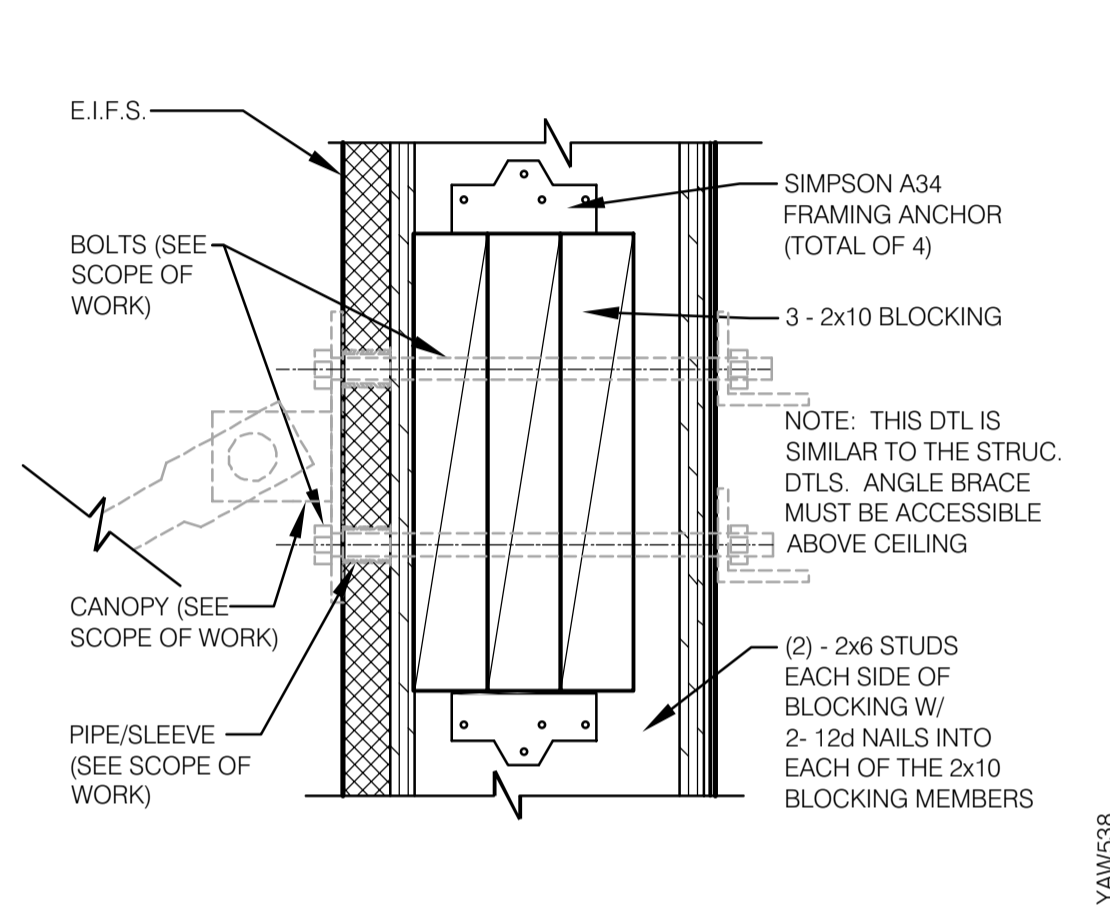

**CANOPY TIE-ROD BLOCKING DETAIL** 3' = 1'-0" **6**

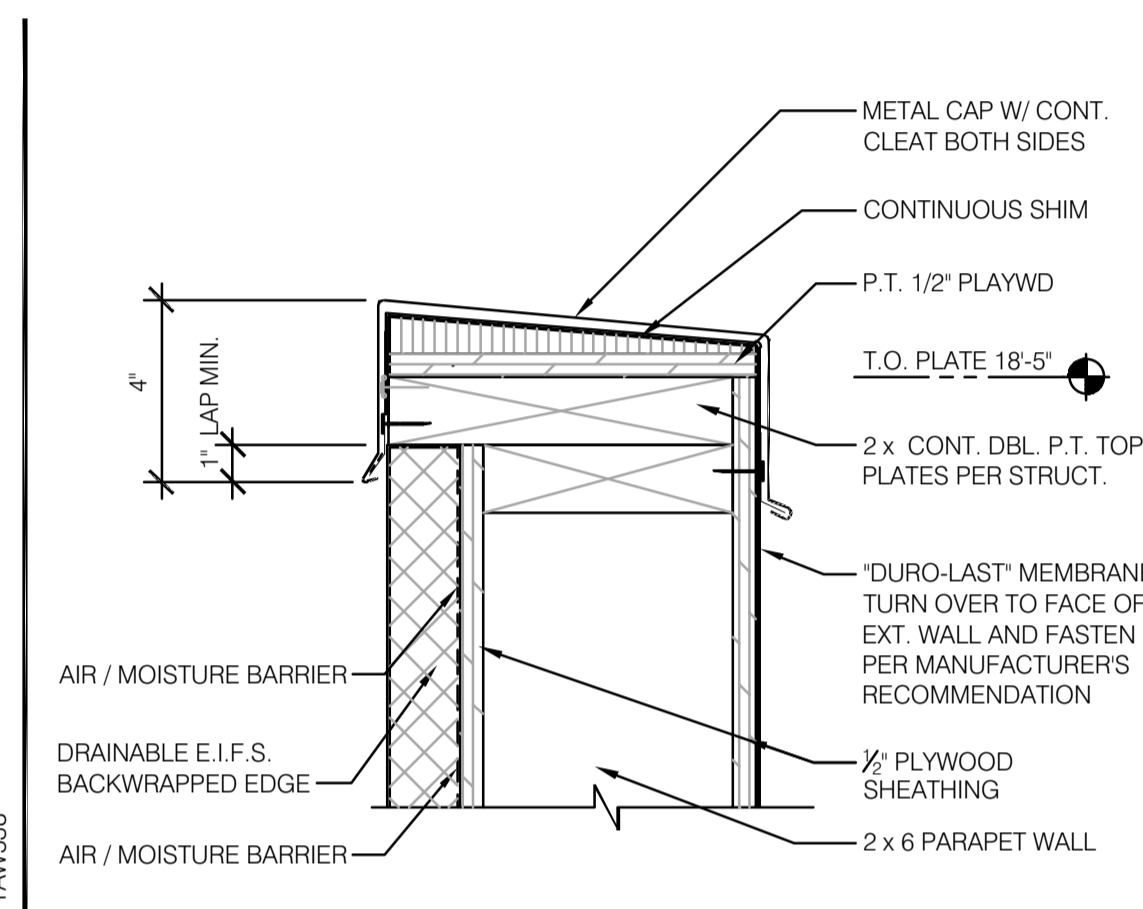

**PARAPET COPING TYPICAL** 3' = 1'-0" **2**

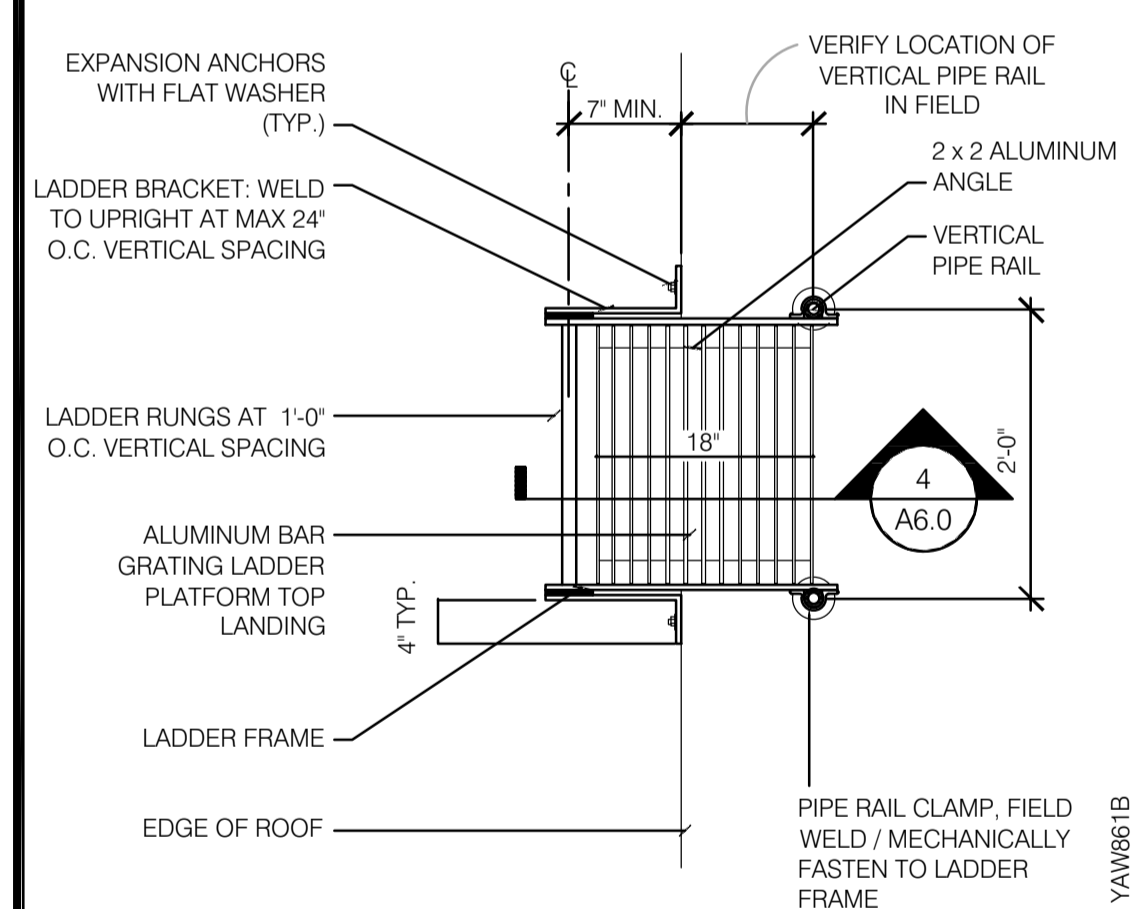

**ROOF LADDER** 1' = 1'-0" **19**

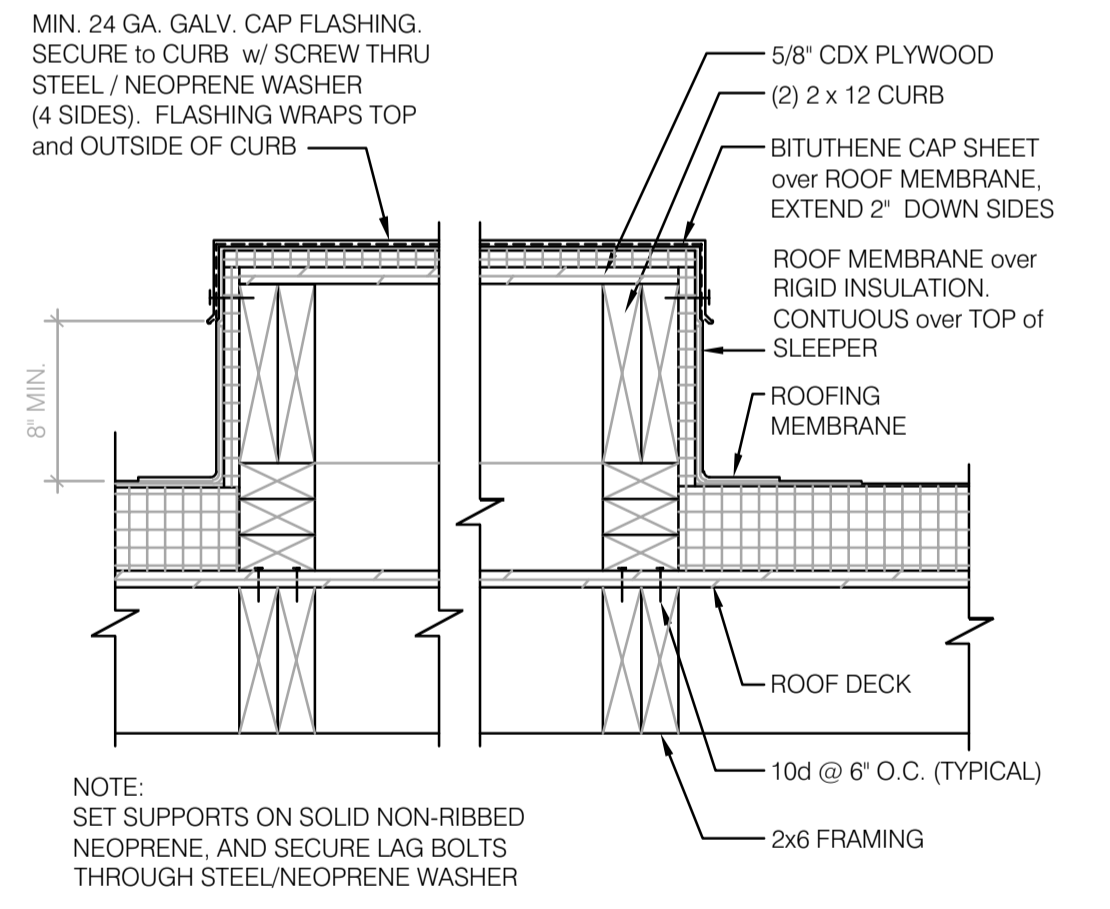

**SLEEPER SUPPORT** 1 1/2' = 1'-0" **15**



**SEALED PIPE FLASHING** 1 1/2' = 1'-0" **12**

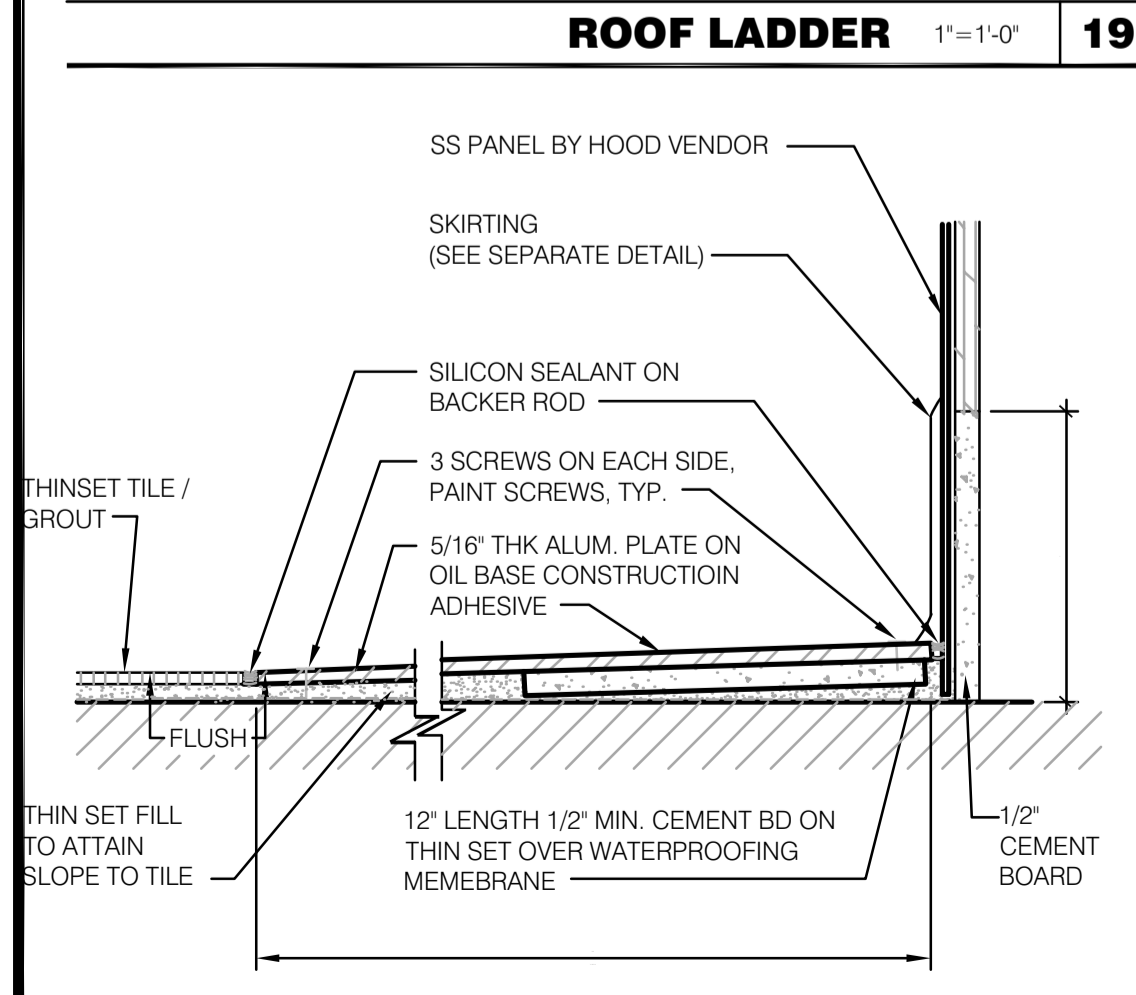

**ALUM. FLR. PLATE DETAIL** 3' = 1'-0" **20**

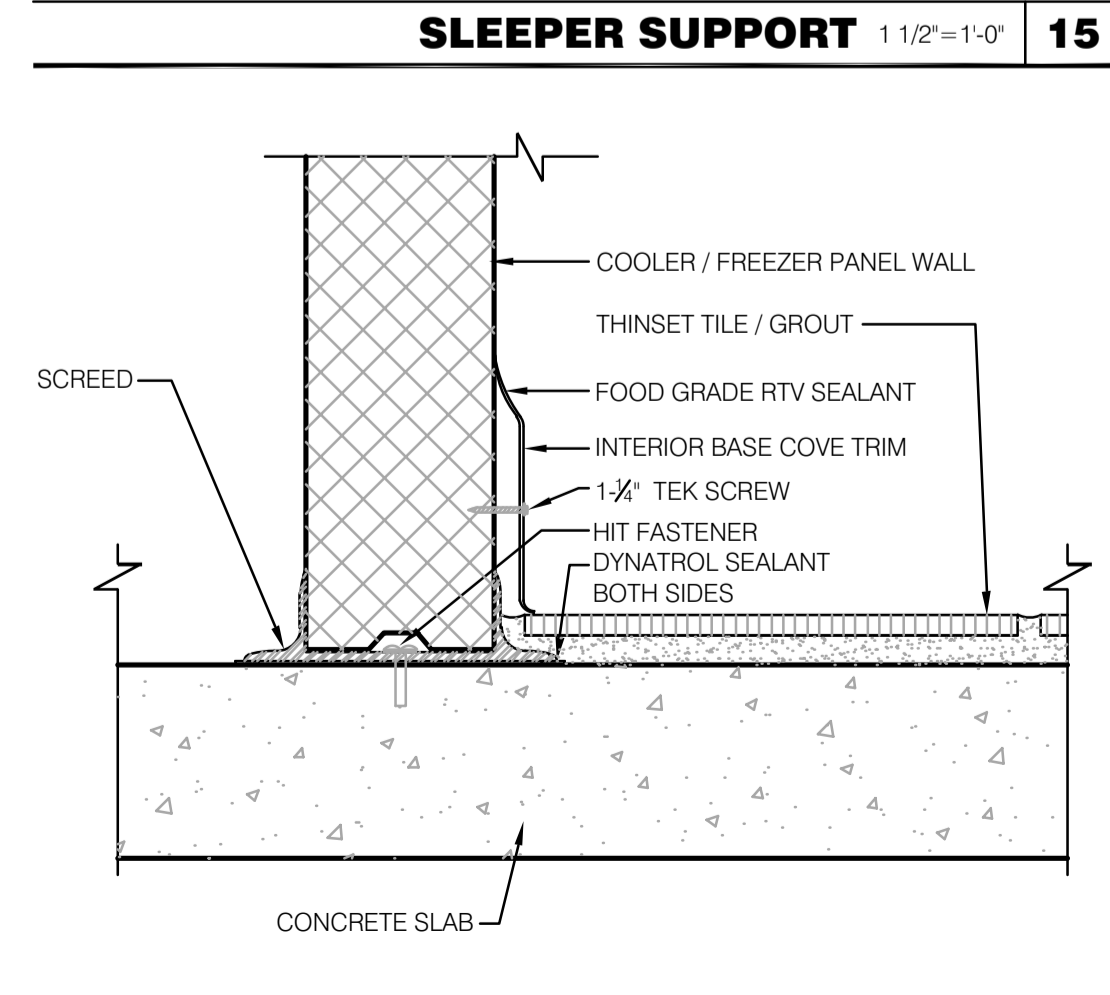

**TILE/BASE at COOLER/FREEZER** 3' = 1'-0" **16**

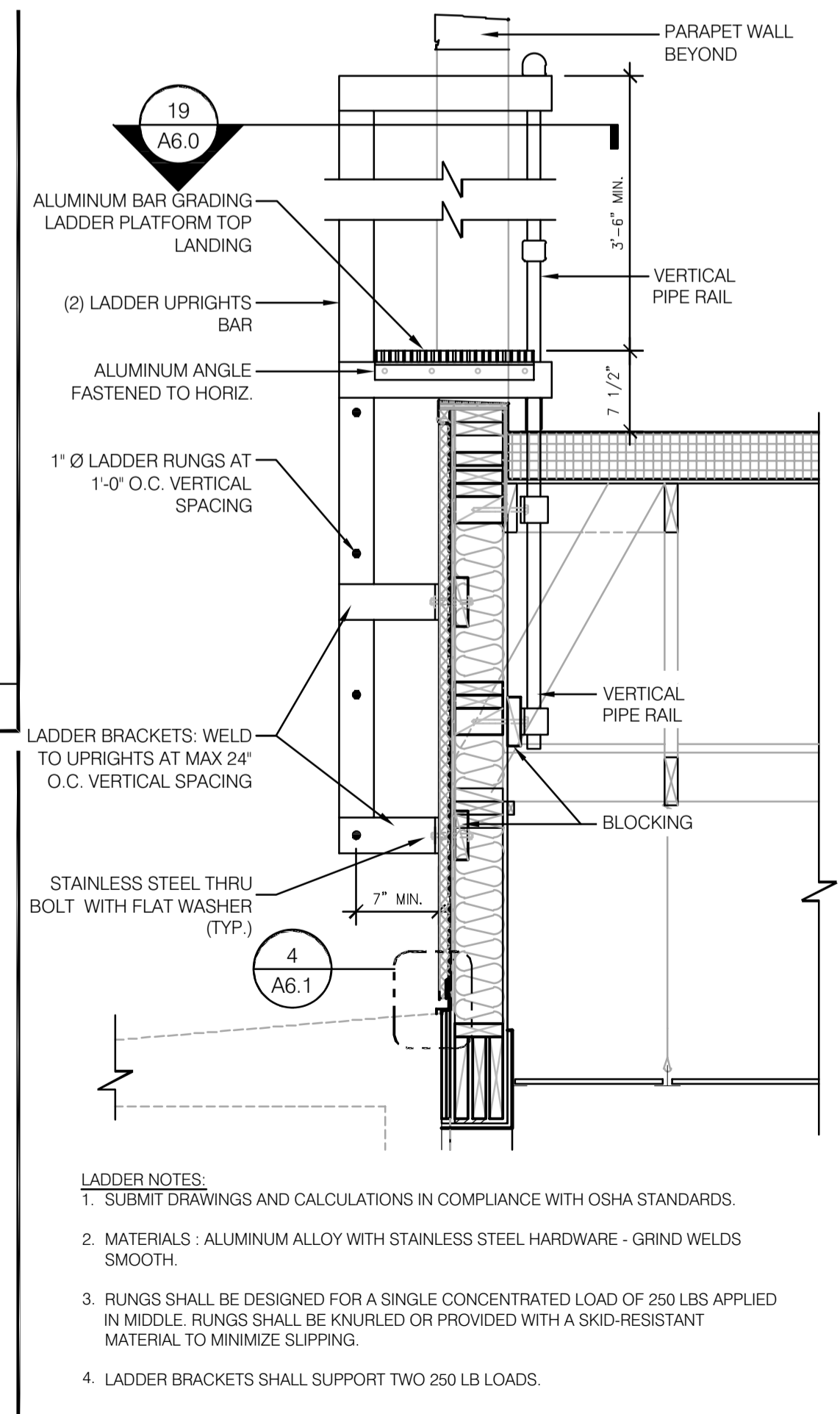
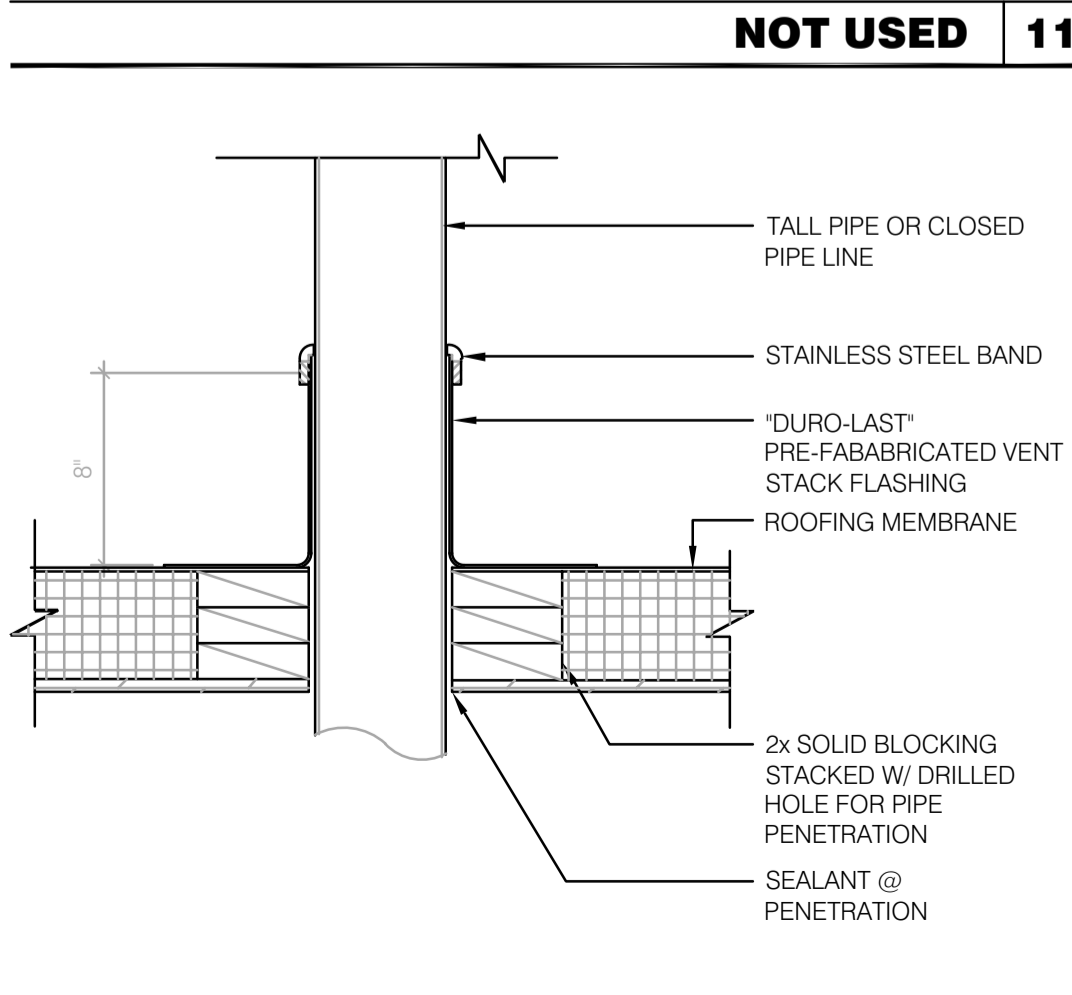

**ROOF LADDER** 1' = 1'-0" **4**

- LADDER NOTES:**
- SUBMIT DRAWINGS AND CALCULATIONS IN COMPLIANCE WITH OSHA STANDARDS.
  - MATERIALS: ALUMINUM ALLOY WITH STAINLESS STEEL HARDWARE - GRIND WELDS SMOOTH.
  - RUNGS SHALL BE DESIGNED FOR A SINGLE CONCENTRATED LOAD OF 250 LBS APPLIED IN MIDDLE. RUNGS SHALL BE KNURLED OR PROVIDED WITH A SKID-RESISTANT MATERIAL TO MINIMIZE SLIPPING.
  - LADDER BRACKETS SHALL SUPPORT TWO 250 LB LOADS.

ENGINEERING OFFICE  
21430 Palm Beach Blvd.  
Avala, Fla. 33920  
Phone: (239) 693-9244  
Facsimile: (239) 693-9828

ARCHITECTURE  
ENGINEERING

**LIS**

LAND INVESTMENT SERVICES, LLC  
AA 26002040 CA NO: 6853 LB1057

ARCHITECTURE / ENGINEERING OFFICE  
2572 West State Road 426  
Suite 2064, Oviedo, FL 32765  
Phone: (321) 244-0402  
Facsimile: (321) 244-9419



Digitally signed by Harold Hutter  
DN: c=US, o=Unaffiliated,  
ou=A01410C000001734E2BCCF  
00000303, cn=Harold Hutter  
Date: 2022.03.31 15:20:55 -04'00'

HAROLD DANIEL HUTTER III  
FL. REG. AR98913

PLAN SET REVISIONS:

△	
△	
△	
△	
△	
△	
△	
△	
△	
△	
△	
△	

CONTRACT DATE: ...-2019

BUILDING TYPE: Kb 30-19

PLAN VERSION: 2018.A

SITE NUMBER:

ENTITY NUMBER:

STORE NUMBER:

LIS PROJECT: 2019-304

**KFC**

3615 W SILVER SPRINGS BLVD.  
OCALA, FL

Kb 30-19

**CONSTRUCTION  
DETAILS**

**A6.0**

PLOT DATE: 03/29/2022