

Circuit	AMP	PHASE	WIRE	LOAD	L.T.G.	RECEP.	EQUIP.	PANELBOARD SCHEDULE								L.T.G.	LOAD	WIRE	P	AMP	Ckt								
								M														A							
								REFER TO ONE-LINE														REFER TO ONE-LINE							
								OTHER PH	OTHER EQUIP.	RECEP.	L.T.G.	PHASE	WIRE	AMP	Ckt							OTHER PH	OTHER EQUIP.	RECEP.	L.T.G.	PHASE	WIRE	AMP	Ckt
1	200	3	#3/0	PANEL A	17152	3420	8322	3000	A	0	32520	14877	0	PANEL B	#1/0	3	200	2											
3	50	3	#6	RTU-1					B	0	37781	3840	0	PANEL D	#1/0	3	150	4											
5	50	3	#6	RTU-3					B	9420	9420		RTU-2	#6	3	50	6												
7	20	2	#6	EF-1			800		A									8											
9	20	2	#6	EF-2			1200		A									10											
11	20	2	#12	WALK-IN BOX COOLER CONDENSER					A	3400			FROZEN COKE MACHINE	#10	2	30	12												
13	30	3	#10	WALK-IN BOX FREEZER CONDENSER					B	9420			RTU-4	#6	3	50	14												

Circuit	AMP	PHASE	WIRE	LOAD	L.T.G.	RECEP.	EQUIP.	PANELBOARD SCHEDULE								L.T.G.	LOAD	WIRE	P	AMP	Ckt								
								B														D							
								REFER TO ONE-LINE														REFER TO ONE-LINE							
								OTHER PH	OTHER EQUIP.	RECEP.	L.T.G.	PHASE	WIRE	AMP	Ckt							OTHER PH	OTHER EQUIP.	RECEP.	L.T.G.	PHASE	WIRE	AMP	Ckt
1	20	1	#12	12 V SODA SYSTEM W/ICE					A		1320		P.O.S. RECEPTACLE - DT. WINDOW 1	#12	1	20	2												
3	20	1	#12	P.O.S. RECEPTACLE - DT. WINDOW 2					B	580			FRY FREEZER W/FRY BASKET HOLDER	#12	1	15	4												
5	20	1	#12	P.O.S. RECEPTACLE - DT. WINDOW 3					C	400			BROILER	#10	1	20	6												
7	20	1	#12	DRIVE THRU DRINK DISPENSER			2070		A		1320		P.O.S. RECEPTACLE - DT. WINDOW 1	#12	1	20	8												
9	20	1	#12	BEAR DOOR BUZZER			720		B		376		SERVICE CRT/DT. RECEPTACLE	#12	1	20	10												
11	20	1	#12	DOOR ALARM			720		C	1344			FRY HOOD CONTROL	#12	1	20	12												
13	20	1	#12	WATER HEATER			180		A	700			MEAT FREEZER	#12	1	20	14												
15									B	1560			4 VAT Fryer-1	#12	1	20	16												
17	20	3	#20	SHAKE/SOFTSERVE#1 (SLF)			3120		A		540		DINING AREA RECEPTACLES	#12	1	20	18												
19									B	2600			ICE MACHINE	#12	2	20	20												
23	20	2	#12	COFFEE/TEA BREWER			2704		C		1560		4 VAT Fryer-2	#12	1	20	22												
25	20	1	#12	SHORTENING STORAGE UNIT			500		A	1000			WALL GRAPHICS	#10	1	20	24												
27	20	1	#12	WATER BOOSTER			1428		B		1000		WALL GRAPHICS	#10	1	20	26												
29	20	1	#12	SPARE			500		A		8320		FRY DUMP STATION	#10	2	40	30												
31	20	1	#12	CHICKEN BATTER STATION			500		B				SPARE	#12	1	20	32												
33									C				SPARE	#12	1	20	34												
35	20	3	#10	TRASH COMPACTOR			3058		A	576			POWER SOAK SOAP DISP. (OPT) 4.B.A	#12	1	20	36												
37									B		2280		P.O.S. RECEPTACLE - SERVICE COUNTER	#12	1	30	40												
39	20	1	#12	P.O.S. RECEPTACLE - SERVICE COUNTER			1320		C		721		DINING AREA RECEPTACLE	#12	1	20	42												
43	20	1	#10	ELG BERRG.			850		A				SPARE	#12	1	20	44												
45	20	1	#10	SPARE					C	7197			COOMBI OVEN STEAMER ELECTRIC	#12	3	25	48												
47	20	1	#10	SPARE					A				SPARE	#12	1	20	50												
49	20	1	#10	SPARE					B				SPARE	#12	1	20	52												
51	20	1	#10	SPARE					C				SPARE	#12	1	20	54												
53	20	1	#10	SPARE					A				SPARE	#12	1	20	56												

Sub-Total	Demand Factor	Total Load
17,152	x 1.25	21,440
10,000	x 1.0	10,000
12,137	x 0.50	6,069
54,082	x 1.0	54,082
80,623	x 1.0	80,623
	x 0.25	0
TOTALS WITH NEC FACTORS: VA	173,994	172,214
	VOLTS	AMPS
	208	479

Sub-Total	Demand Factor	Total Load
0	x 1.25	0
10,000	x 1.0	10,000
4,877	x 0.50	2,439
0	x 1.0	0
32,520	x 1.0	32,520
	x 0.25	0
TOTALS WITH NEC FACTORS: VA	47,397	44,959
	VOLTS	AMPS
	208	125

PANELBOARD NOTES:

- PROVIDE ISOLATED GROUND BUS.
- CONTRACTOR SHALL WIRE THESE CIRCUITS THRU MASTER CONTACTOR PANEL. REFERENCE WIRING DIAGRAM SHEET E-5.
- HL PROVIDE HLO-1 HANDLE LOCK-OFF.

CIRCUIT BREAKER SYMBOL DESCRIPTIONS:

TC WIRE THROUGH CONTACTOR
HACR HACR TYPE BREAKER
LO LOCKED BREAKER
GFCI GROUND FAULT CIRCUIT INTERRUPTOR
IG WIRE SEPARATE TO ISOLATED GROUND BUS

Circuit	AMP	PHASE	WIRE	LOAD	L.T.G.	RECEP.	EQUIP.	PANELBOARD SCHEDULE								L.T.G.	LOAD	WIRE	P	AMP	Ckt								
								M														A							
								REFER TO ONE-LINE														REFER TO ONE-LINE							
								OTHER PH	OTHER EQUIP.	RECEP.	L.T.G.	PHASE	WIRE	AMP	Ckt							OTHER PH	OTHER EQUIP.	RECEP.	L.T.G.	PHASE	WIRE	AMP	Ckt
1	20	1	#10	SPARE					C				1200	FLAG POLE LIGHTS	#10	1	20	2											
3	20	1	#10	SPARE					A				800	DINING ROOM LIGHTS	#12	1	20	4											
5	20	1	#10	PREVIEW BOARD LANE 2					C	1200			1500	KITCHEN AREA LIGHTS	#12	1	20	6											
7	20	1	#10	PREVIEW BOARD LANE 1					B	1200			720	OCU LANE 1	#10	1	20	8											
9	20	1	#8	PYLON SIGN			1200		B		900			DIGITAL MENU BOARD	#10	1	20	10											
11	20	1	#10	CHANNEL LETTER / LOGO			1200		C				400	RESTROOM LIGHTS / EF-3	#12	1	20	12											
13	20	1	#10	DRIVE THRU MENU - LANE 2					A		720			DIRECTIONAL SIGNS	#8	1	20	14											
15	20	1	#10	CLEARANCE BARS			600		B				1320	KITCHEN / SERVICE / OFFICE LIGHTS	#12	1	20	16											
17	20	1	#10	MOTION LIGHT - TRASH COMPACTOR			27		C	360				SMOKE DETECTOR ALARM PANEL	#12	1	20	18											
19	20	1	#12	CHANNEL LETTER / LOGO			1200		A	720				OCU LANE 2	#10	1	20	20											
21	20	1	#10	PARKING LIGHT BOARD			340		B	720				RELAY PANEL	#12	1	20	22											
23	20	1	#12	CHANNEL LETTER / LOGO			1200		C				1550	EXTERIOR BUILDING LIGHTS	#12	1	20	24											
25	20	1	#10	DRIVE THRU MENU - LANE 1					A	180				TELEPHONE RECEPTACLE	#12	1	20	26											
27	20	1	#10	EXTERIOR CANOPY LIGHTS			1475		B				180	EXTERIOR RECEPTACLE	#12	1	20	28											
29	20	1	#12	COOK / FRIZR LIGHTS / DOOR HR. / HE.			400		C	540				KITCHEN RECEPTACLES	#12	1	20	30											
31	20	1	#12	EXTERIOR RECEPTACLES			720		A					SPARE	#12	1	20	32											
33	20	1	#12	SERVICE COUNTER / CORRIDOR			360		B					SPARE	#12	1	20	34											
35	20	1	#12	DRY FREEZE / SERVICE CAMERA			540		C				720	OFFICE RECEPTACLES	#12	1	20	36											
37	20	1	#12	KITCHEN AREA LIGHTS			1200		A					WALK-IN COOLER & FREEZER EVAPORATORS	#12	2	20	38											
39	20	1	#12	CREW / STORAGE RECEPTACLES			720		B		2222			SAFE	#12	2	20	40											
41	20	1	#12	CHANNEL LETTER / LOGO			1200		C	300				SAFE	#12	1	20	42											

Sub-Total	Demand Factor	Total Load
17,152	x 1.25	21,440
3,420	x 1.0	3,420
0	x 0.50	0
3,000	x 1.0	3,000
8,322	x 1.0	8,322
	x 0.25	0
TOTALS WITH NEC FACTORS: VA	31,894	36,182
	VOLTS	AMPS
	208	101

Sub-Total	Demand Factor	Total Load
0	x 1.25	0
3,840	x 1.0	3,840
0	x 0.50	0
0	x 1.0	0
37,781	x 1.0	37,781
	x 0.25	0
TOTALS WITH NEC FACTORS: VA	41,621	41,621
	VOLTS	AMPS
	208	116

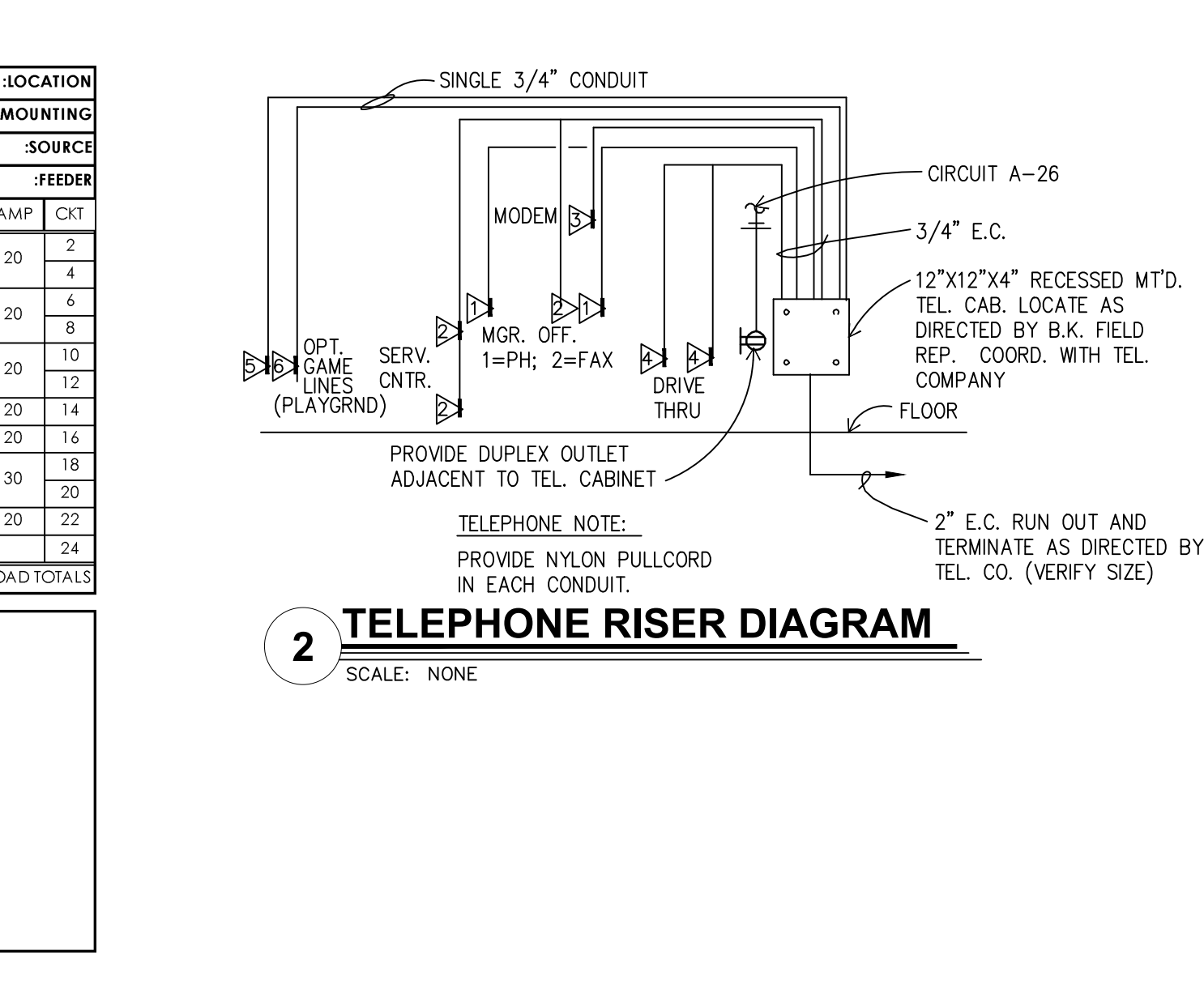
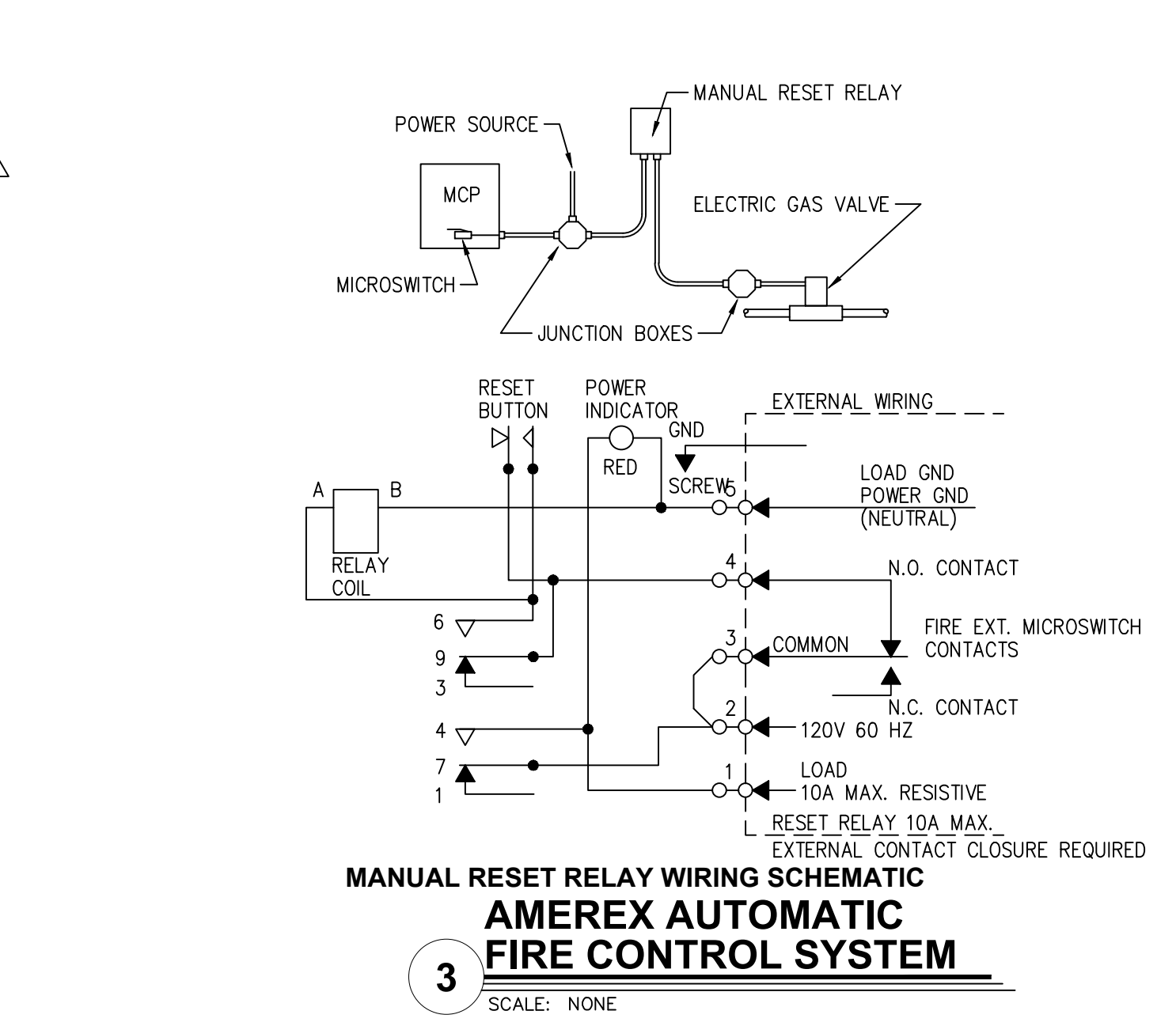
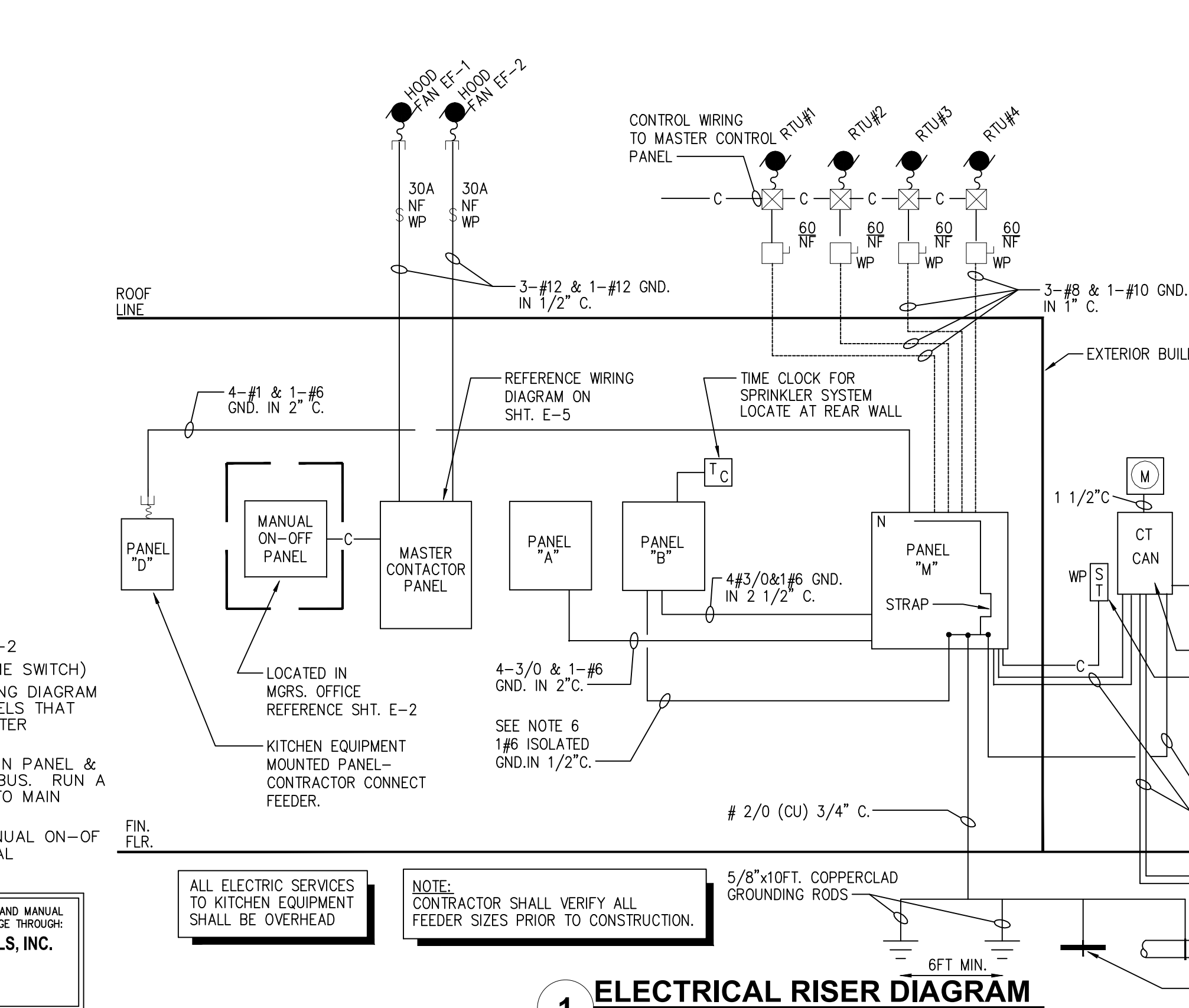

Issued:		Date:	
A	BKC Approval		10/29/2021
B	Permit Set		1/21/2022
C	Bid Set		1/24/2022
D	Construction Set		3/14/2022
E			

Revisions:		Date:	
1	Addendum # 1		02/08/22
2	Addendum # 2		02/21/22
3			
4			
5			
6			
7			
8			
9			

Copyright © 2022 APD Engineering & Architecture, LLC

Drawing Alteration

It is a violation of law for any person, unless acting under the direction of licensed Architect, Professional Engineer, Landscape Architect, or Land Surveyor to alter any item on this document in any way. Any licensee who alters this document is required by law to affix his or her seal and to add the notation "Altered by followed by his or her signature and the specific description of the alteration or revision."

DO NOT SCALE PLANS

Copying, Printing, Software and other processes required to produce these prints can stretch or shrink the actual paper or layout. Therefore, scaling of this drawing may be inaccurate. Contact APD E&A with any need for additional dimensions or clarifications.

APD ENGINEERING ARCHITECTURE

615 Fishers Run Victor, NY 14564
585.742.2222 - www.apd.com

Ampler Development LLC

4700 Falls of Neuse Rd
Suite 400
Raleigh, NC 27609
phone: (919) 484-0965

Burger King Inc. Store #

322 Pottstown Ave
Pennsburg, PA 18073
Montgomery County

Project Name & Location: