



FCC COMMERCIAL FURNITURE INC.  
8452 OLD HWY 99 N. ROSEBURG, OR 97470 USA  
T: 800.322.7328 | F: 541.673.7441 | WWW.FCCFURN.COM  
DESIGNED AND BUILT IN U.S.A.

PROPERTY OF FCC COMMERCIAL FURNITURE  
THIS IS A FOR DESIGN PURPOSE TO EXPRESS DESIGN CONCEPTS TO THE ARCHITECT, CLIENT, CONTRACTOR AND INSTALLER FOR THE PROJECT SHOWN. THIS DESIGN AND THE CONCEPTS HEREIN SHALL NOT BE ALTERED OR USED AS CONSTRUCTION DOCUMENTS. DO NOT REPRODUCE OR LEND WITHOUT WRITTEN PERMISSION FROM FCC COMMERCIAL FURNITURE INC.

**IMPORTANT**

WRITTEN DIMENSIONS HAVE PRECEDENCE OVER SCALE IN ALL CASES.

DO NOT SCALE OFF PLANS. CONTACT FCC COMMERCIAL FURNITURE'S REPRESENTATIVE TO VERIFY ANY QUESTIONABLE DIMENSIONS AT TELEPHONE # 800.322.7328

THE GENERAL CONTRACTOR MUST VERIFY ALL BUILDING DIMENSIONS, EQUIPMENT, FURNITURE PLACEMENT, UTILITY LOCATIONS, AND CONDITIONS AT THE JOB SITE.

THE GENERAL CONTRACTOR MUST NOTIFY FCC COMMERCIAL FURNITURE OF ALL DISCREPANCIES AND/OR REQUIRED ADJUSTMENTS PRIOR TO STARTING WORK.

FCC COMMERCIAL FURNITURE HAS PREPARED THESE DOCUMENTS AS ACCURATELY AS POSSIBLE WITH THE ARCHITECTURAL INFORMATION PROVIDED. DUE TO LACK OF ACCURATE AND COMPLETE DIMENSIONED ARCHITECTURAL PLANS, OWNER UNDERSTANDS THAT ADJUSTMENTS TO THE FINAL LOCATIONS OF EQUIPMENT AND/OR FURNITURE PLACEMENT MAY BE REQUIRED AT THE OWNER'S EXPENSE DUE TO DISCREPANCIES BASED ON ACTUAL JOB SITE DIMENSIONS AND CONDITIONS.

REFER TO ARCHITECTURAL OR ENGINEER DRAWINGS FOR COMPLETE AND ACCURATE DIMENSIONS OF BUILDING STRUCTURE.

THESE CONTRACT DOCUMENTS AND THE INFORMATION THEY CONTAIN ARE THE PROPERTY OF FCC COMMERCIAL FURNITURE INC., ROSEBURG, OREGON, 97470.

ALL PREPARED CONTRACT DOCUMENTS MAY NOT BE COPIED, REPRODUCED, USED OR IMPLEMENTED IN ANY WAY, IN PART OR IN WHOLE, WITHOUT THE EXPRESS WRITTEN CONSENT OF FCC COMMERCIAL FURNITURE INC.

ANY UNAUTHORIZED USE OF THESE PLANS WILL RESULT IN PAYMENT DUE FOR SERVICES RENDERED BY FCC COMMERCIAL FURNITURE INC.

ANY DEVIATIONS FROM THESE DRAWINGS FOR ANY REASON SHALL NOT BE DONE WITHOUT CONSENT OF FCC COMMERCIAL FURNITURE INC. IN ADVANCE. IN WRITING. FCC COMMERCIAL FURNITURE IS NOT RESPONSIBLE FOR DEVIATIONS, CHANGES, ADDITIONS, OR DELETIONS NOT REVIEWED AND APPROVED IN ADVANCE BY FCC COMMERCIAL FURNITURE INC.

THESE DOCUMENTS REFLECT SPECIFIC SEATING AND DECOR EQUIPMENT ORDERED OF DATE SHOWN BELOW.

CLIENT:



Burger King  
322 Pottstown Ave.  
Pennsburg, PA 18073  
Decor: Garden Grill  
Building Type: ROC-2502T

CUSTOMER  
Ampler Development

SHEET TITLE:  
INTERIOR BUILDING  
ELEVATIONS

WORK ORDER NUMBER:

FINALS BY:

DRAWN BY:  
Joe Logsdon  
SCALE:  
1/4" = 1'-0"  
ORIGINAL DATE:  
December 7, 2021

PLOT DATE:  
March 14, 2022  
PROJECT #:

**22834-001**

SHEET #:  
**D2.3**

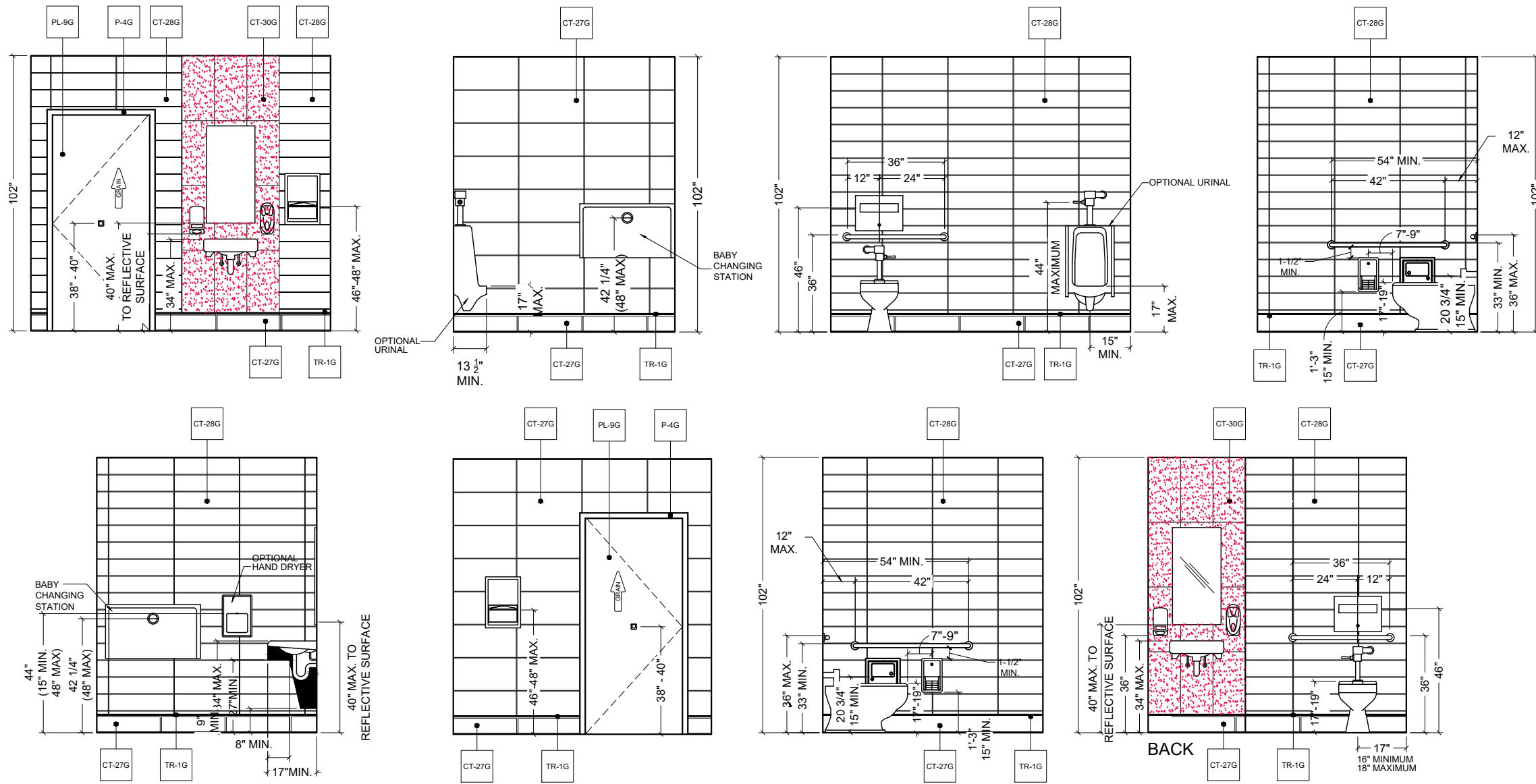

**TYPICAL RESTROOM FINISH ELEVATIONS**

RE : WALL FINISH PLAN

NOTE:  
REFER TO 20/20 GARDEN GRILL DECOR GUIDELINES FOUND AT DESIGNWITHBK.COM (INTERIOR DESIGN GUIDELINES) FOR REQUIRED RESTROOM GRAPHICS.

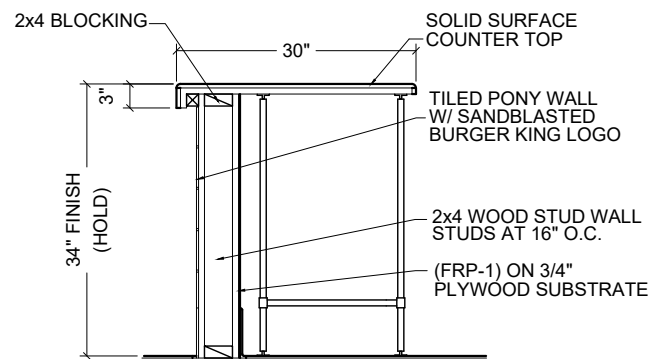

**1** SECTION AT SERVICE COUNTER (F12A)  
N.T.S.

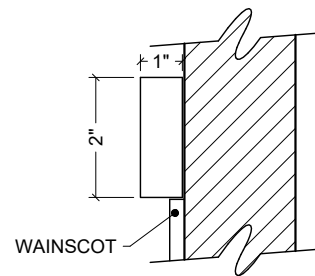

**2** SECTION AT CHAIR RAIL (B6A)  
N.T.S.

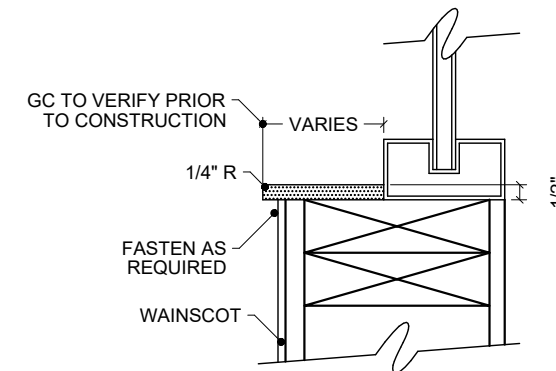

**3** SECTION AT WINDOW SILLS (B10A)  
N.T.S.