

REV	DATE	DESCRIPTION	BY	CHKD	DATE	DESCRIPTION	BY	CHKD	DATE	DESCRIPTION
07	JFA	4/11/13	No Change							
06	JFA	11/25/11	MOVE C-12634 REV 01 TO C-12634 REV 6 BK APPROVED #							

REV	DATE	DESCRIPTION	BY	CHKD	DATE	DESCRIPTION	BY	CHKD	DATE	DESCRIPTION
07	JFA	4/11/13	No Change							
06	JFA	11/25/11	MOVE C-12634 REV 01 TO C-12634 REV 6 BK APPROVED #							

REV	DATE	DESCRIPTION	BY	CHKD	DATE	DESCRIPTION	BY	CHKD	DATE	DESCRIPTION
07	JFA	4/11/13	No Change							
06	JFA	11/25/11	MOVE C-12634 REV 01 TO C-12634 REV 6 BK APPROVED #							

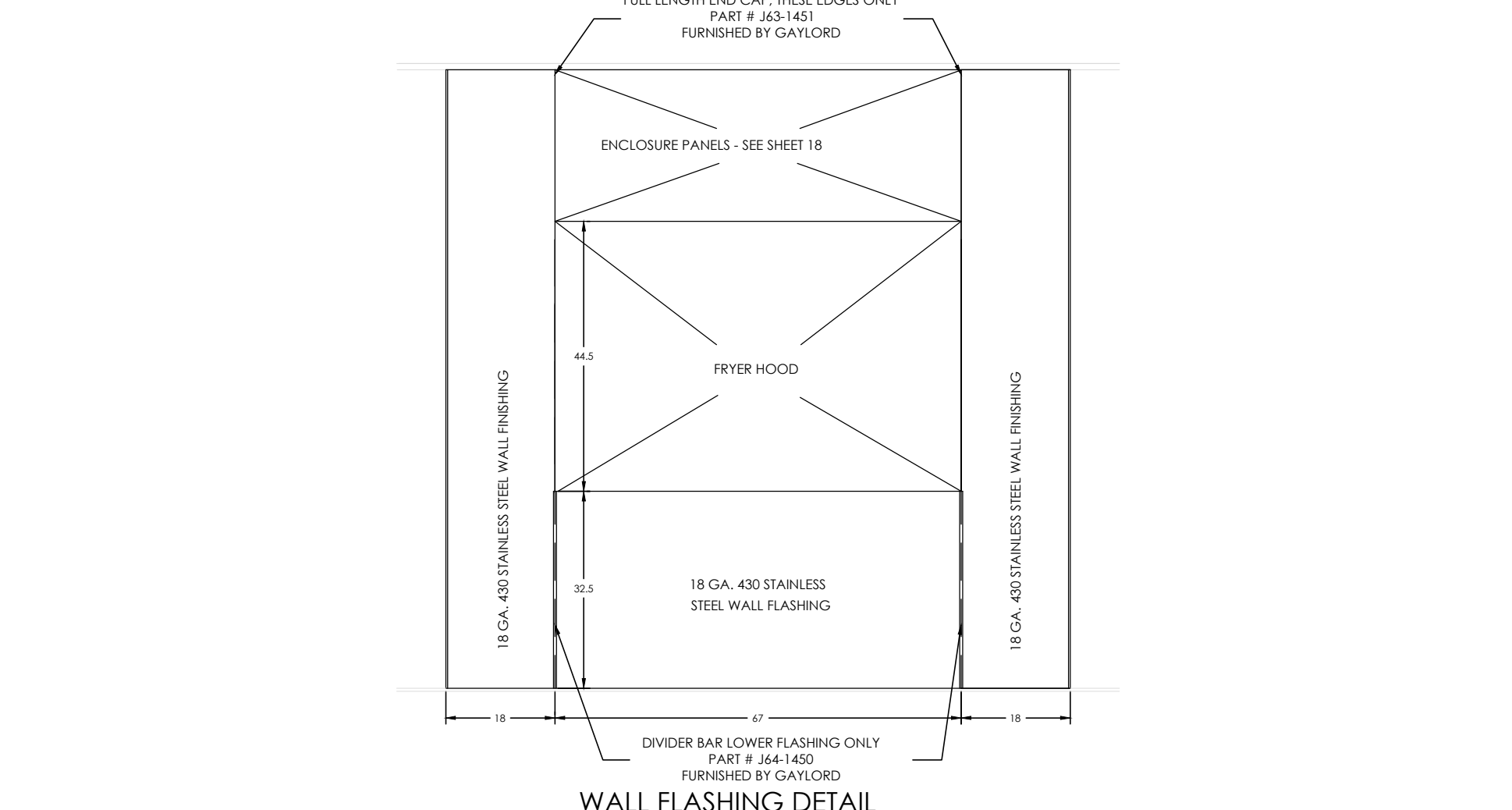
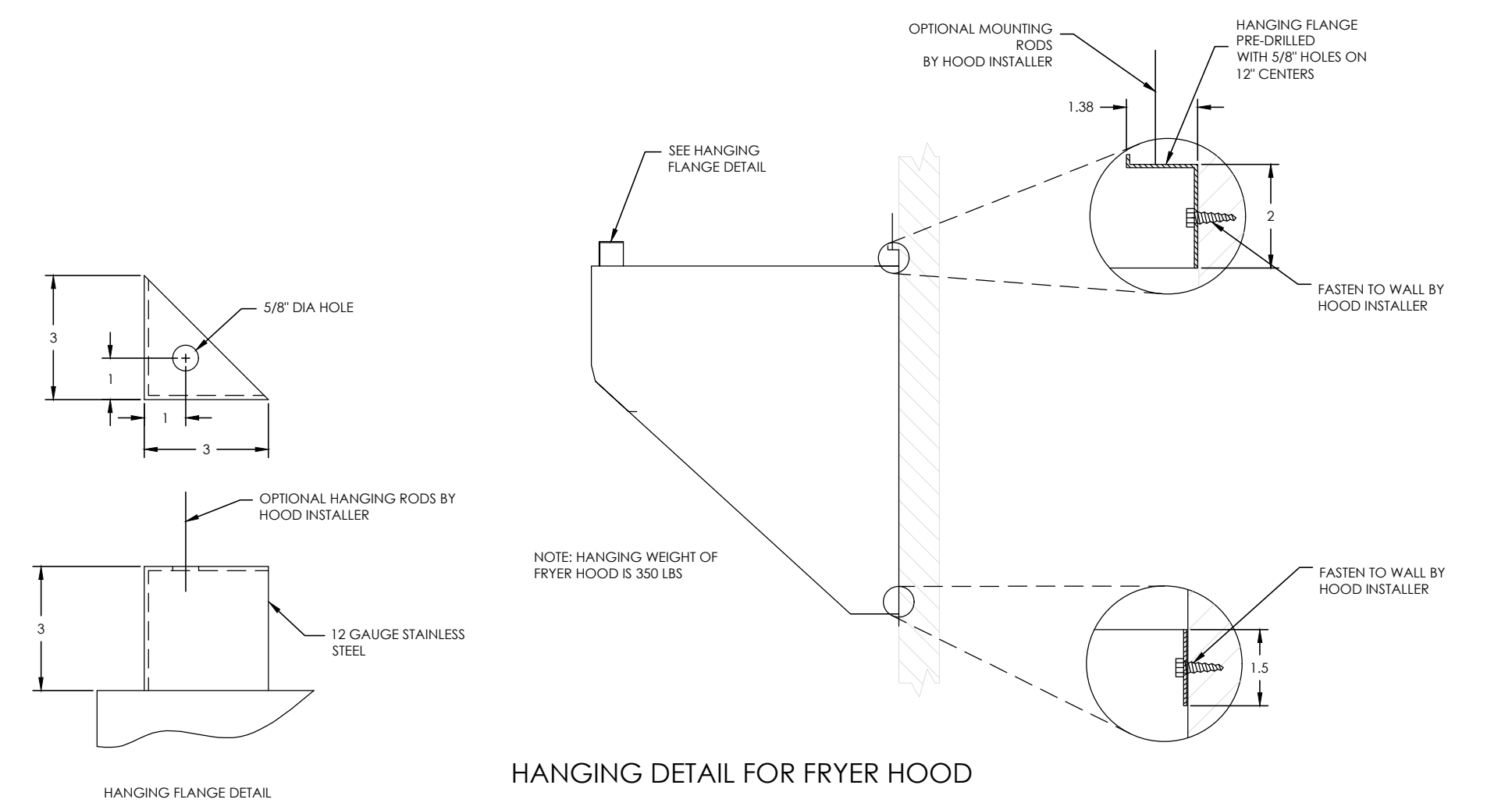
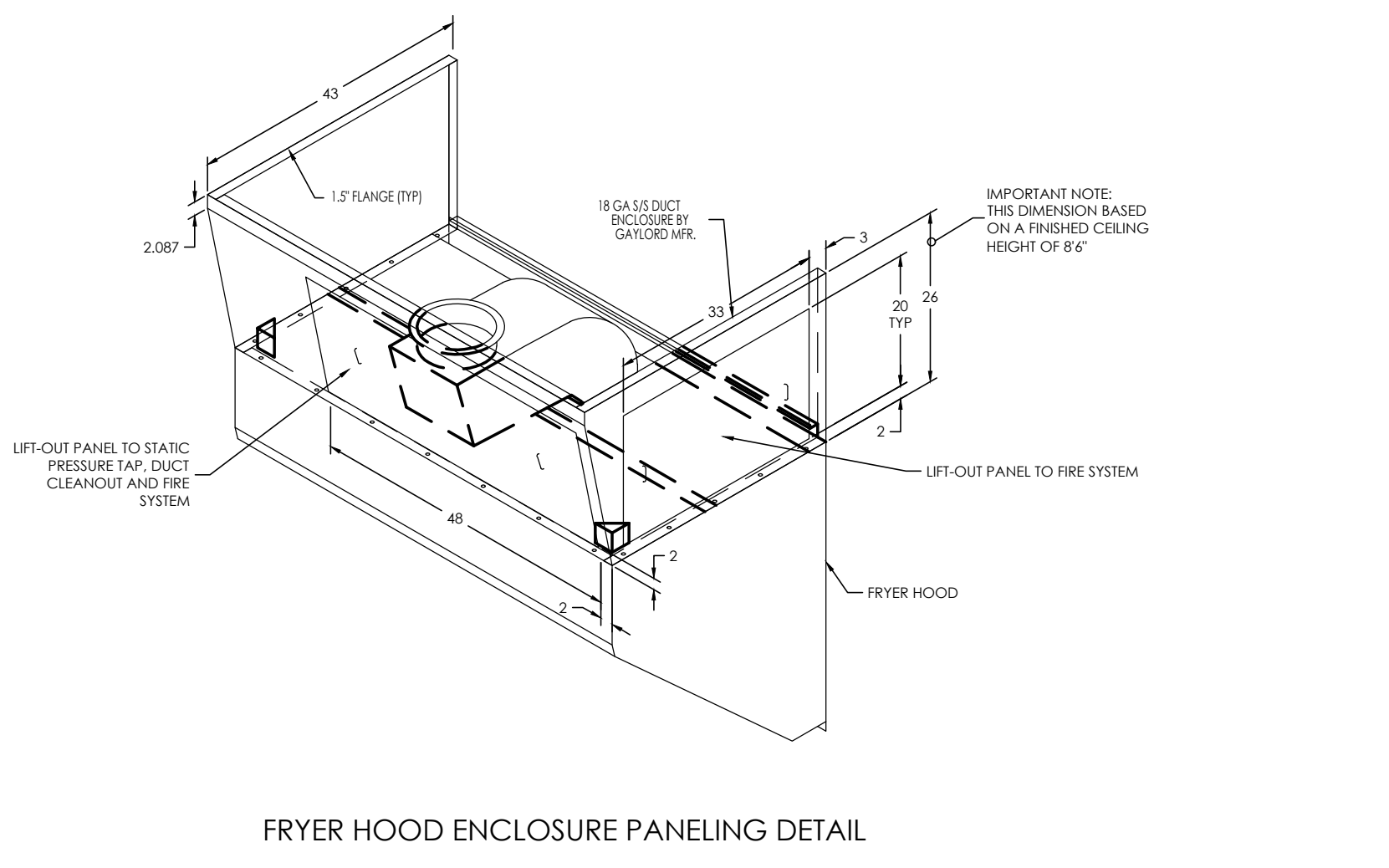

REV	DATE	DESCRIPTION	BY	CHKD	DATE	DESCRIPTION	BY	CHKD	DATE	DESCRIPTION
07	JFA	4/11/13	No Change							
06	JFA	11/25/11	MOVE C-12634 REV 01 TO C-12634 REV 6 BK APPROVED #							

REV	DATE	DESCRIPTION	BY	CHKD	DATE	DESCRIPTION	BY	CHKD	DATE	DESCRIPTION
07	JFA	4/11/13	No Change							
06	JFA	11/25/11	MOVE C-12634 REV 01 TO C-12634 REV 6 BK APPROVED #							

REV	DATE	DESCRIPTION	BY	CHKD	DATE	DESCRIPTION	BY	CHKD	DATE	DESCRIPTION
07	JFA	4/11/13	No Change							
06	JFA	11/25/11	MOVE C-12634 REV 01 TO C-12634 REV 6 BK APPROVED #							

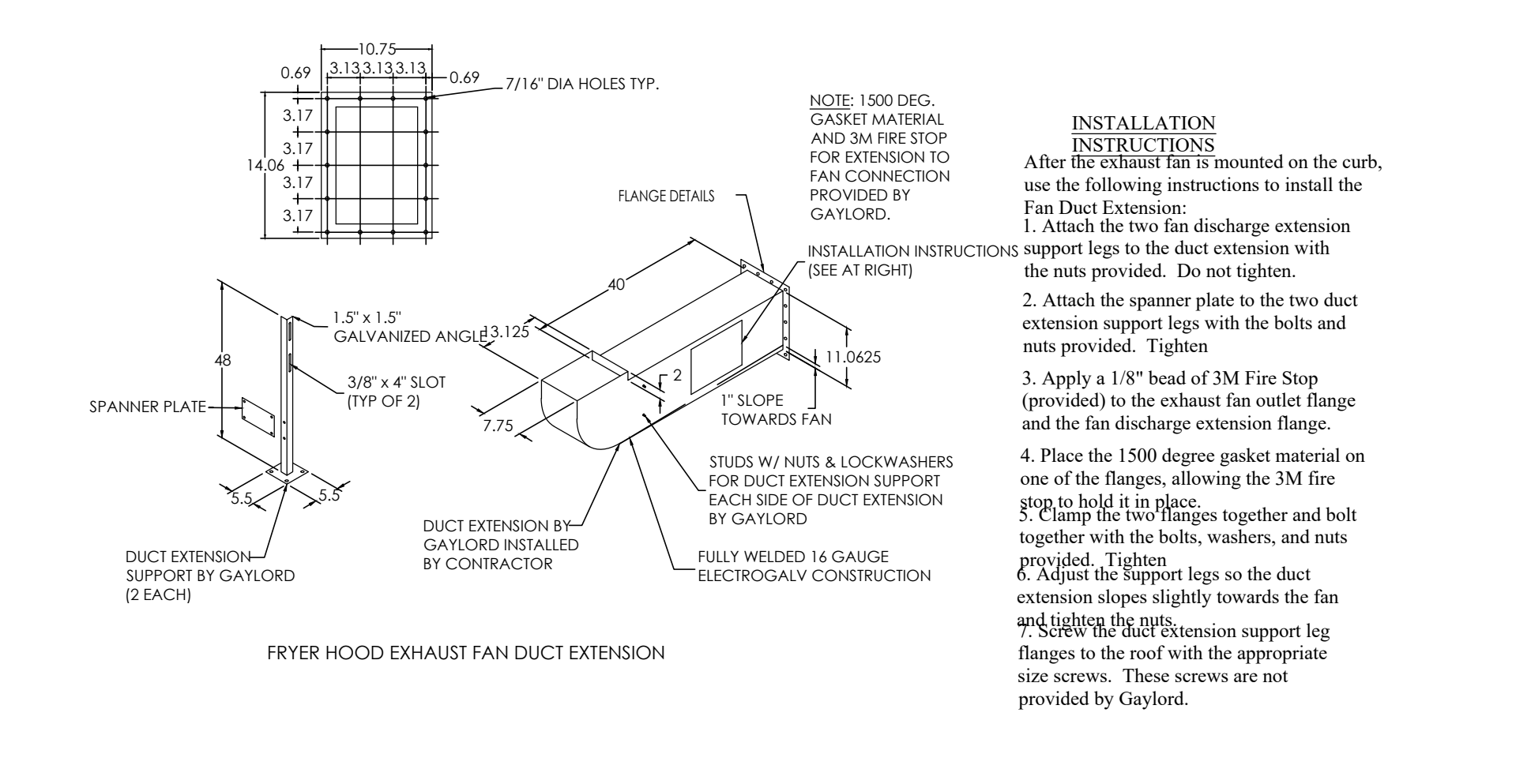
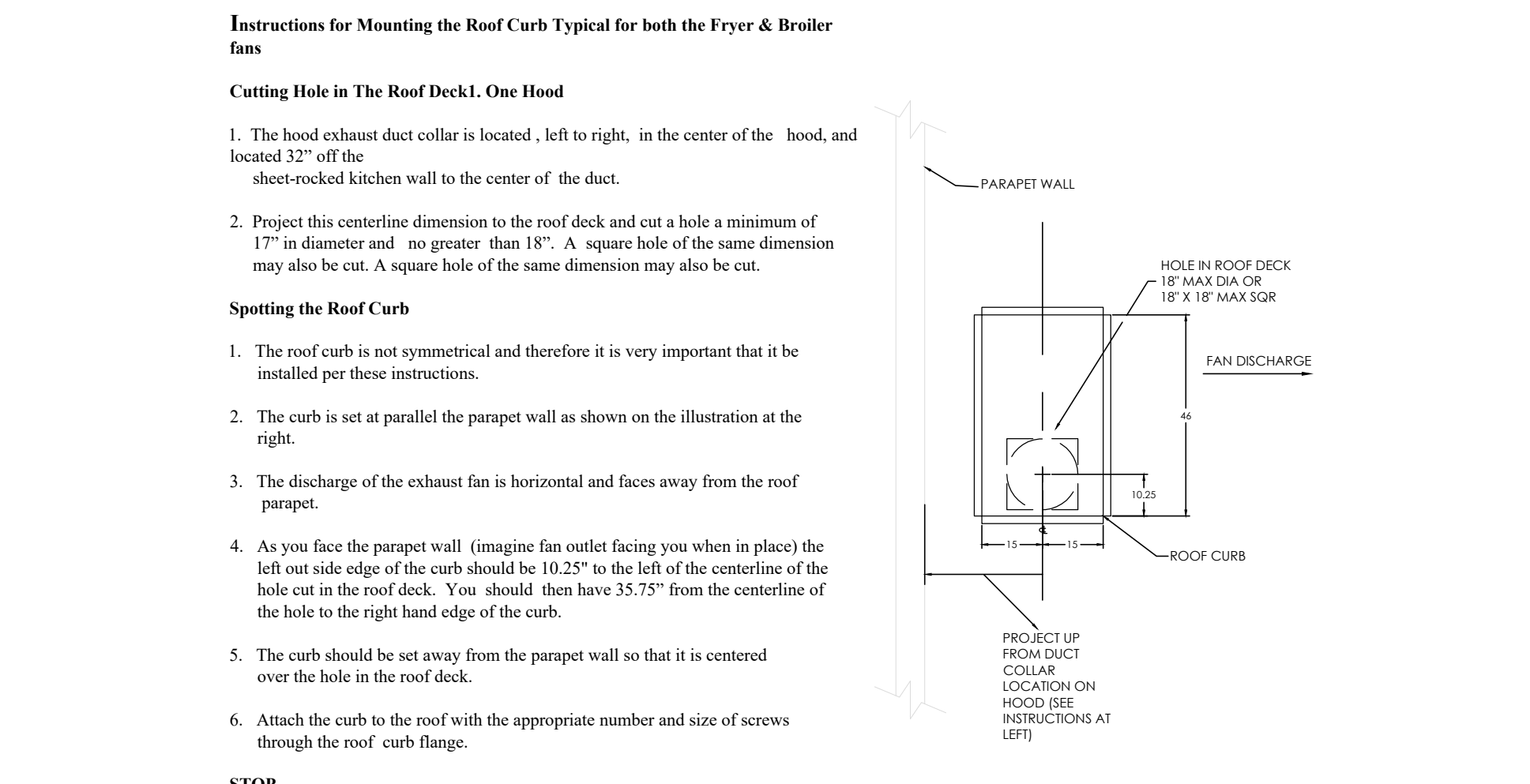
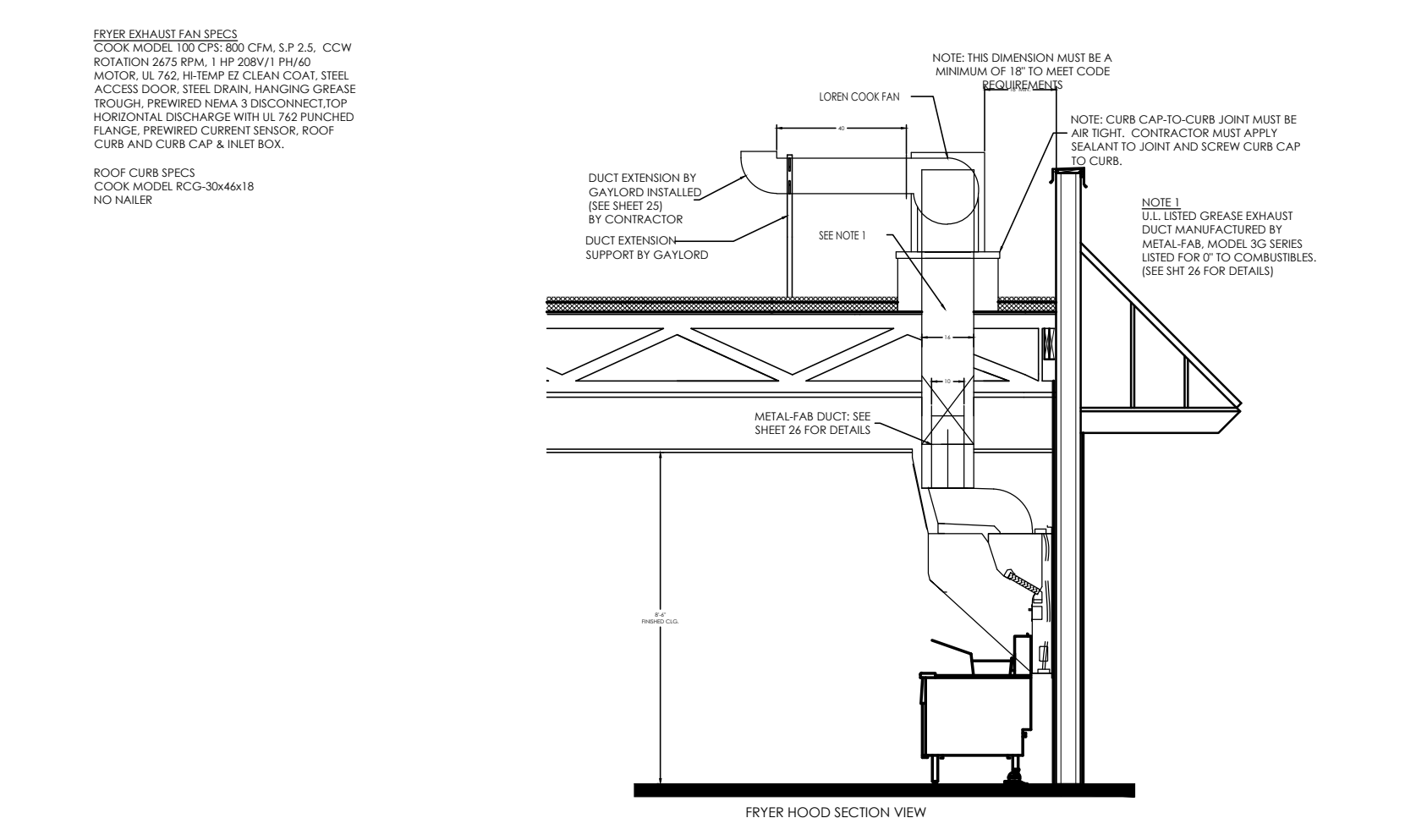

REV	DATE	DESCRIPTION	BY	CHKD	DATE	DESCRIPTION	BY	CHKD	DATE	DESCRIPTION
07	JFA	4/11/13	No Change							
06	JFA	11/25/11	MOVE C-12634 REV 01 TO C-12634 REV 6 BK APPROVED #							

REV	DATE	DESCRIPTION	BY	CHKD	DATE	DESCRIPTION	BY	CHKD	DATE	DESCRIPTION
07	JFA	4/11/13	No Change							
06	JFA	11/25/11	MOVE C-12634 REV 01 TO C-12634 REV 6 BK APPROVED #							

REV	DATE	DESCRIPTION	BY	CHKD	DATE	DESCRIPTION	BY	CHKD	DATE	DESCRIPTION
07	JFA	4/11/13	No Change							
06	JFA	11/25/11	MOVE C-12634 REV 01 TO C-12634 REV 6 BK APPROVED #							

No.	Date	By	Notes
3	5/26/21	DB	PLANNING SUBMITTAL
4	7/27/21	DB	BUILDING SUBMITTAL
5	8/27/21	AS	BUILDING REVISIONS
6	10/29/21	AS	ENGINEERING REVISIONS
7	12/10/21	AS	BUILDING REVISIONS 2

Drawn By: CP
Checked: SB
Scale: AS NOTED
Date: 03.24.21

ALL RIGHTS RESERVED. NO PART OF THESE DRAWINGS OR SPECIFICATIONS MAY BE REPRODUCED OR USED IN CONNECTION WITH ANY WORK OTHER THAN THE SPECIFIC PROJECT FOR WHICH THEY HAVE BEEN PREPARED, WITHOUT PRIOR WRITTEN AUTHORIZATION FROM THE ARCHITECT.

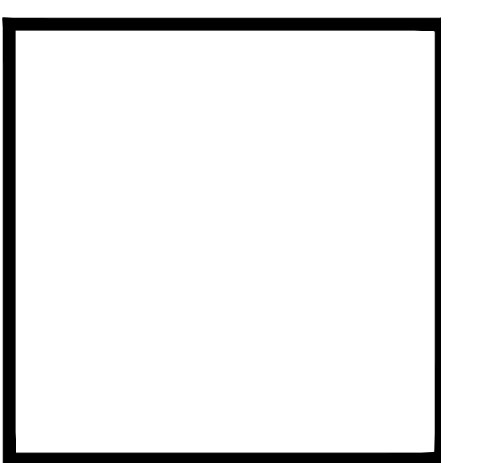
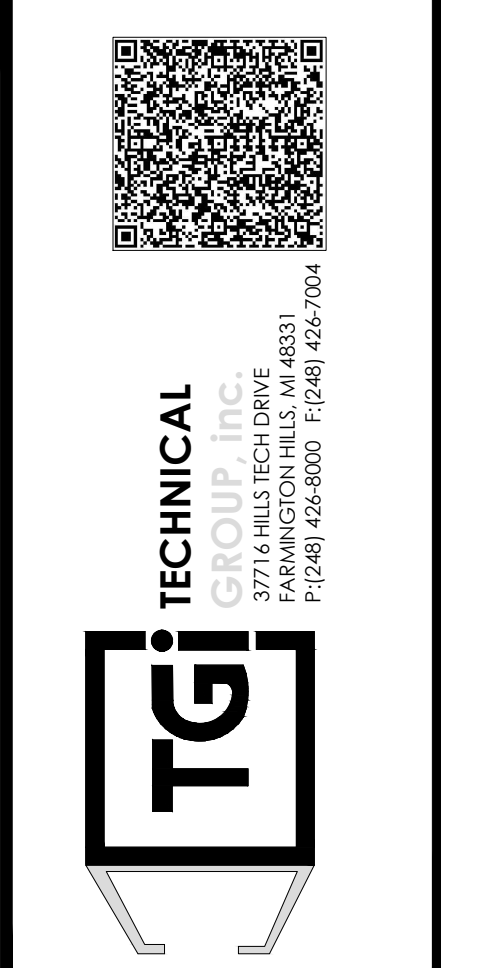
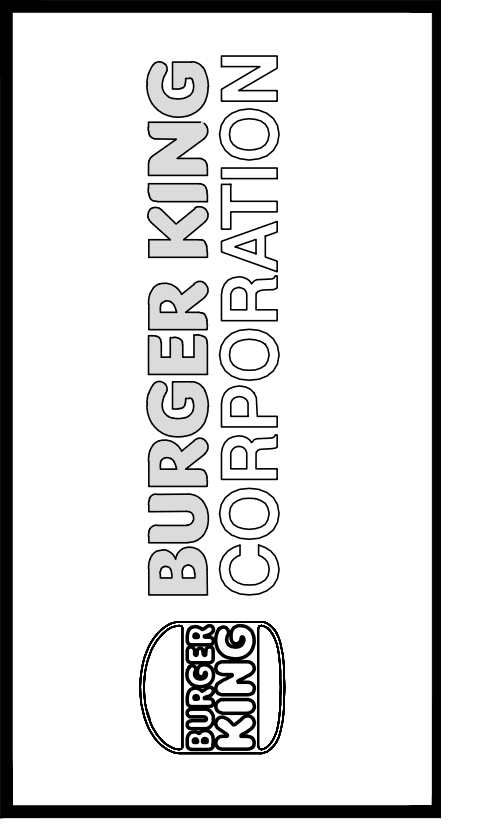

REV	DATE	DESCRIPTION	BY	CHKD	DATE	DESCRIPTION	BY	CHKD	DATE	DESCRIPTION
07	JFA	4/11/13	No Change							
06	JFA	11/25/11	MOVE C-12634 REV 01 TO C-12634 REV 6 BK APPROVED #							