

**1** PLAN DETAIL  
SCALE: 1-1 / 2" = 1'-0"

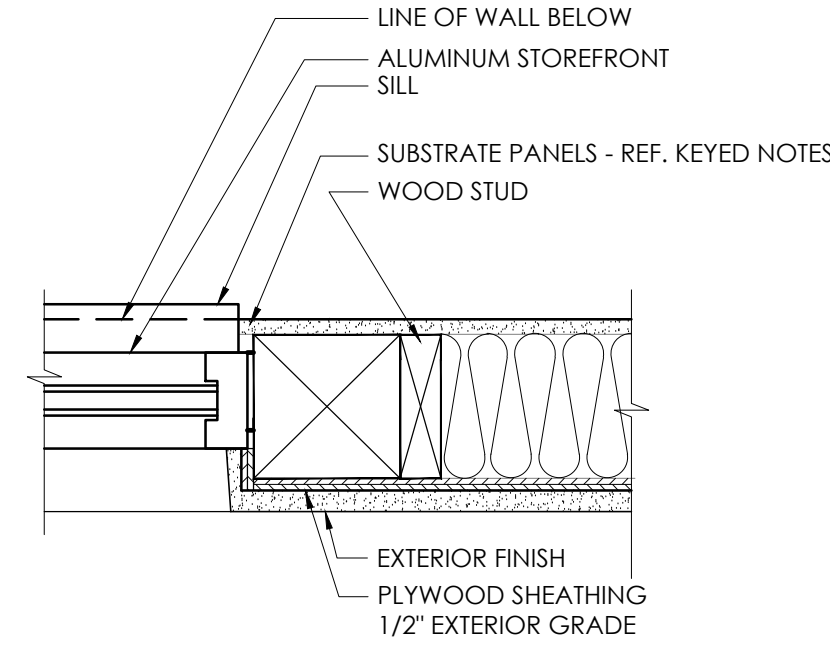

**2** PLAN DETAIL  
SCALE: 1-1 / 2" = 1'-0"

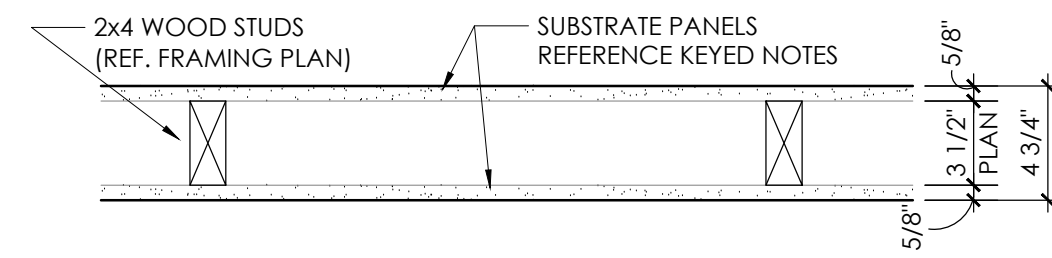

**3** TYPICAL INTERIOR PARTITION  
SCALE: 1-1 / 2" = 1'-0"

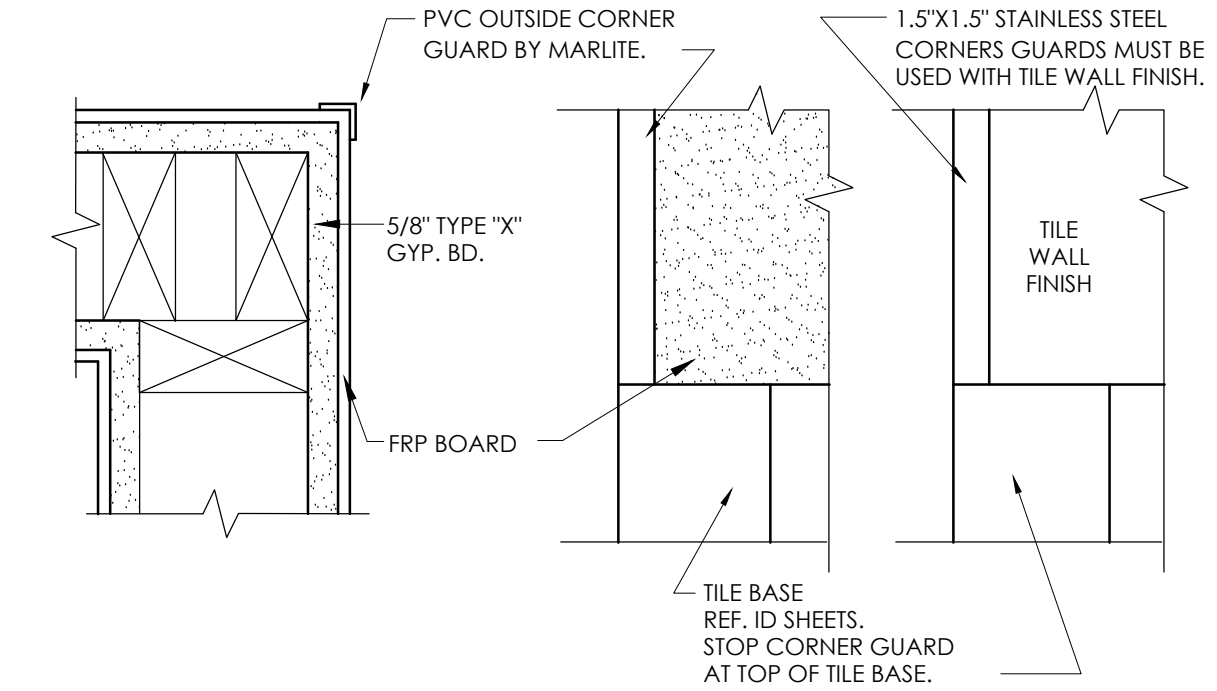

PLAN VIEW ELEVATION

**4** CORNER GUARD DETAIL  
SCALE: 1-1 / 2" = 1'-0"

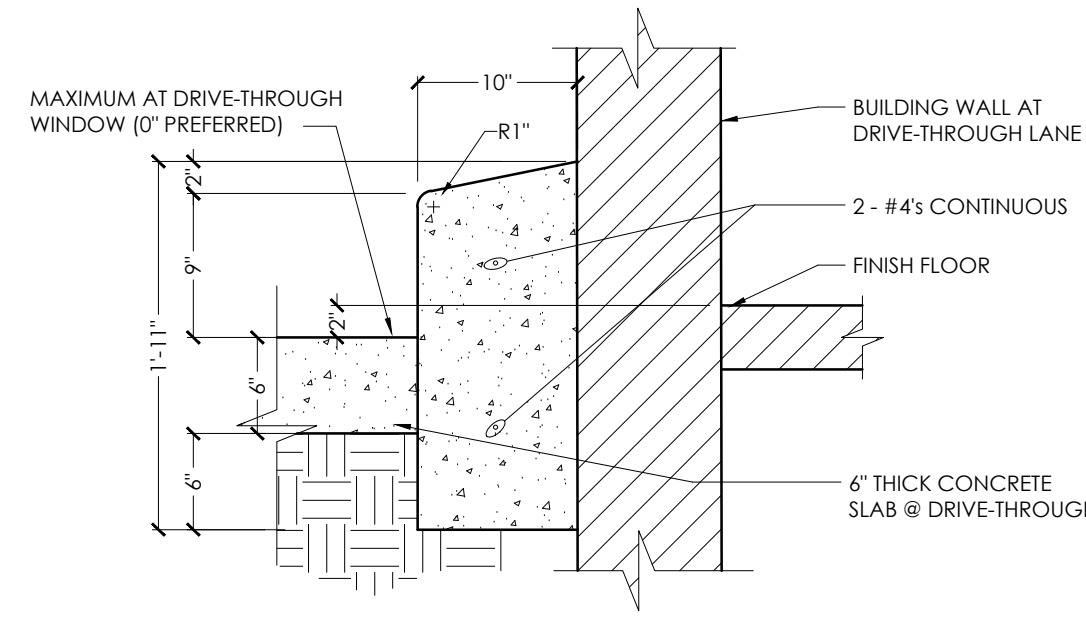

**5** BARRIER CURB DETAIL  
SCALE: 1-1 / 2" = 1'-0"

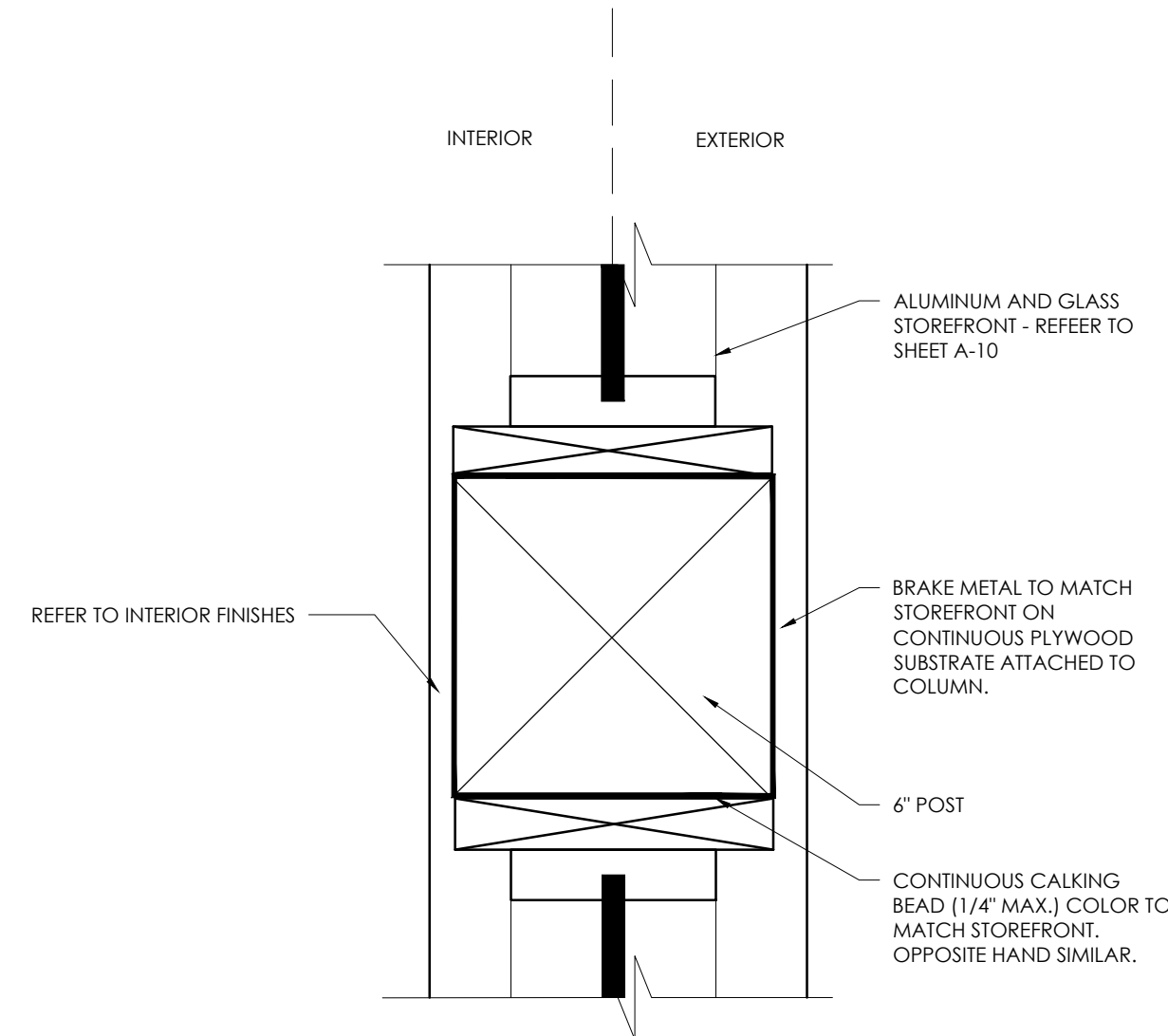

**6** COLUMN BRAKE METAL ENCLOSURE  
SCALE: 3" = 1'-0"

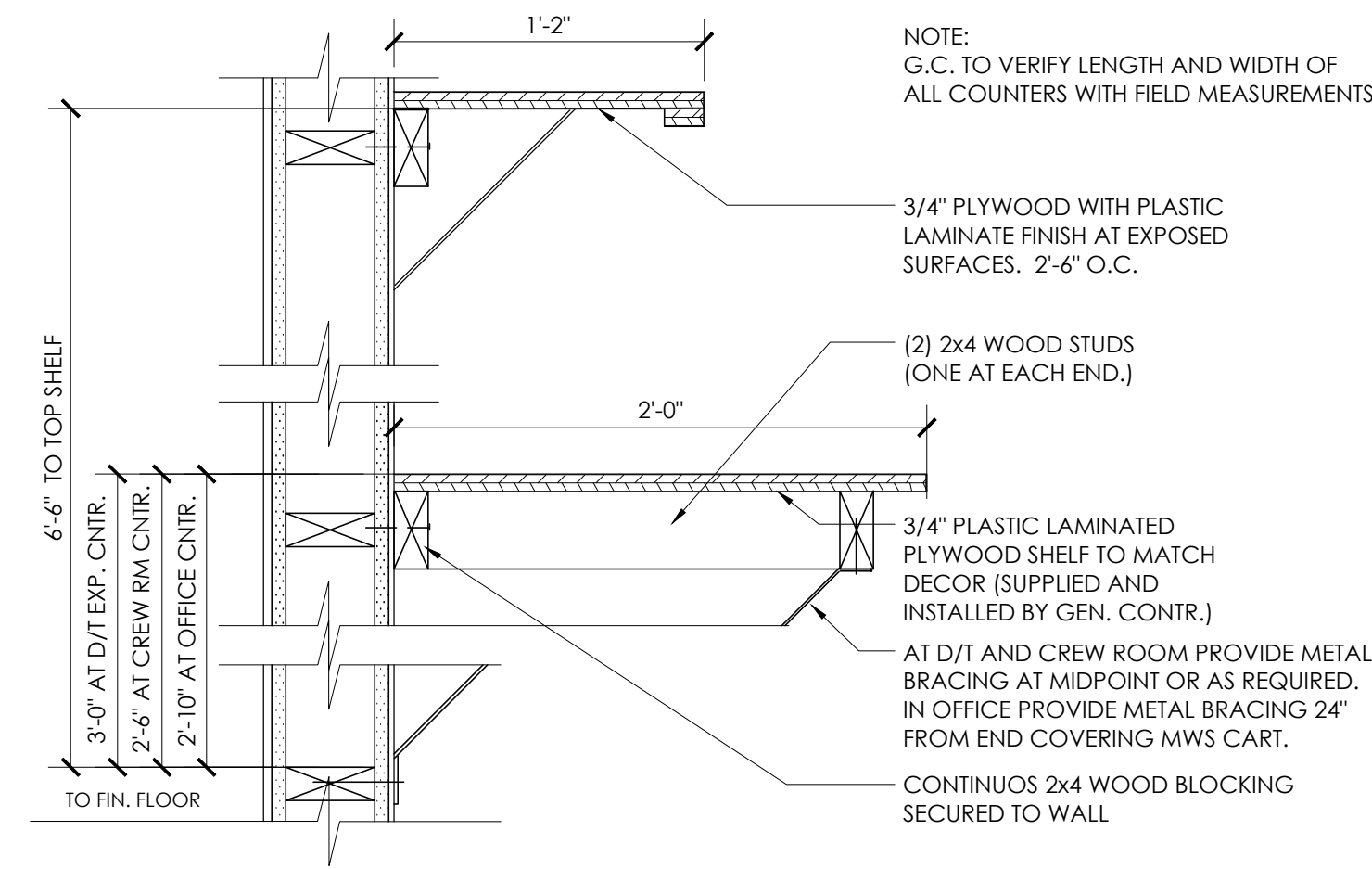

**7** OFFICE COUNTER DETAIL  
SCALE: 1-1 / 2" = 1'-0"

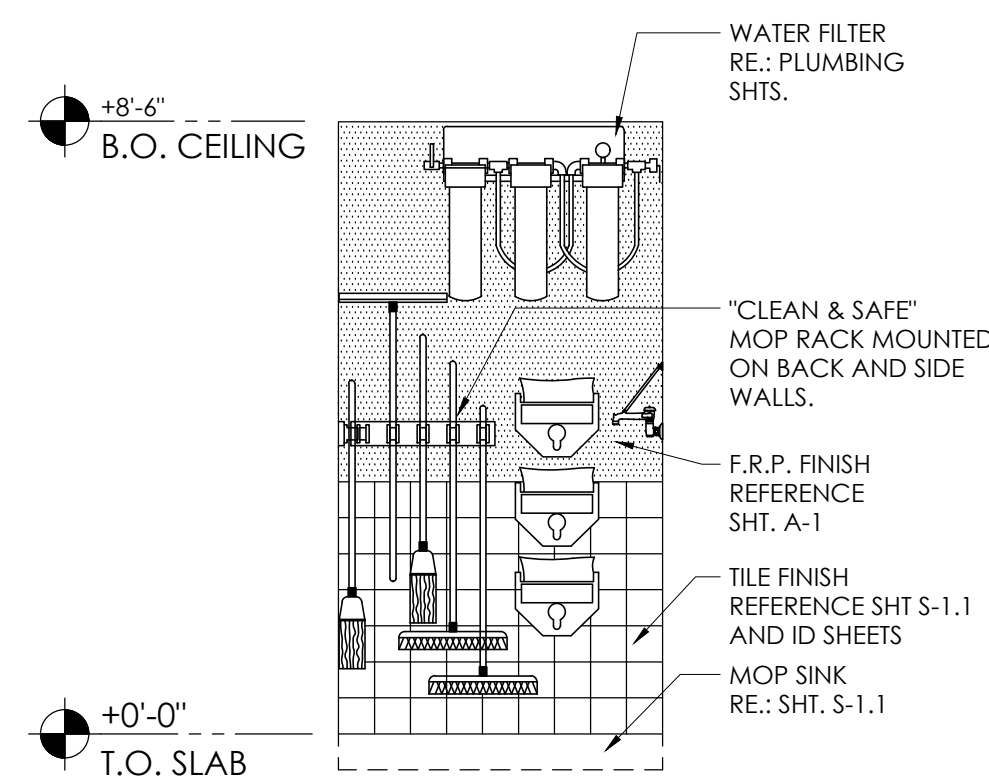

**A** ELEVATION  
SCALE: 3/8" = 1'-0"

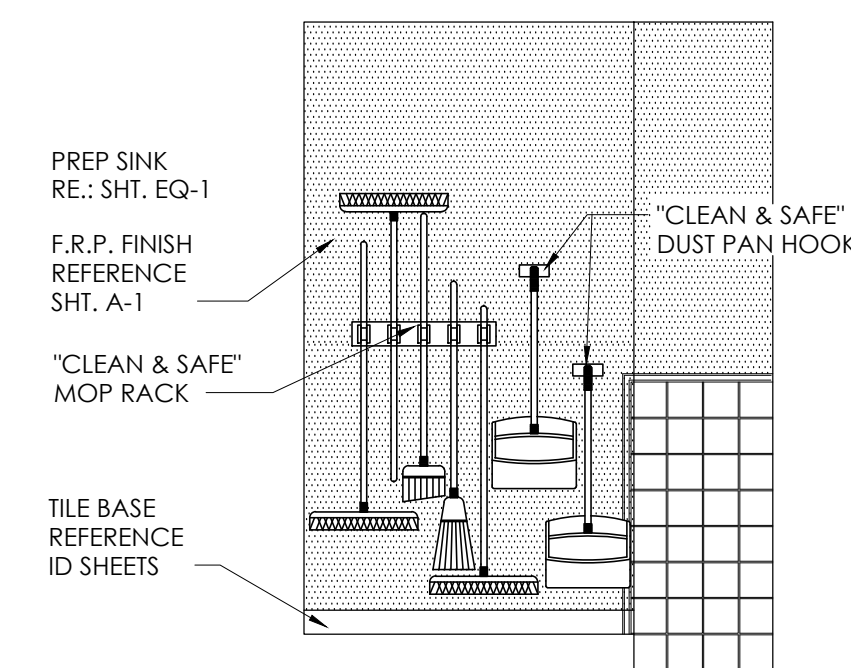

**B** ELEVATION  
SCALE: 3/8" = 1'-0"

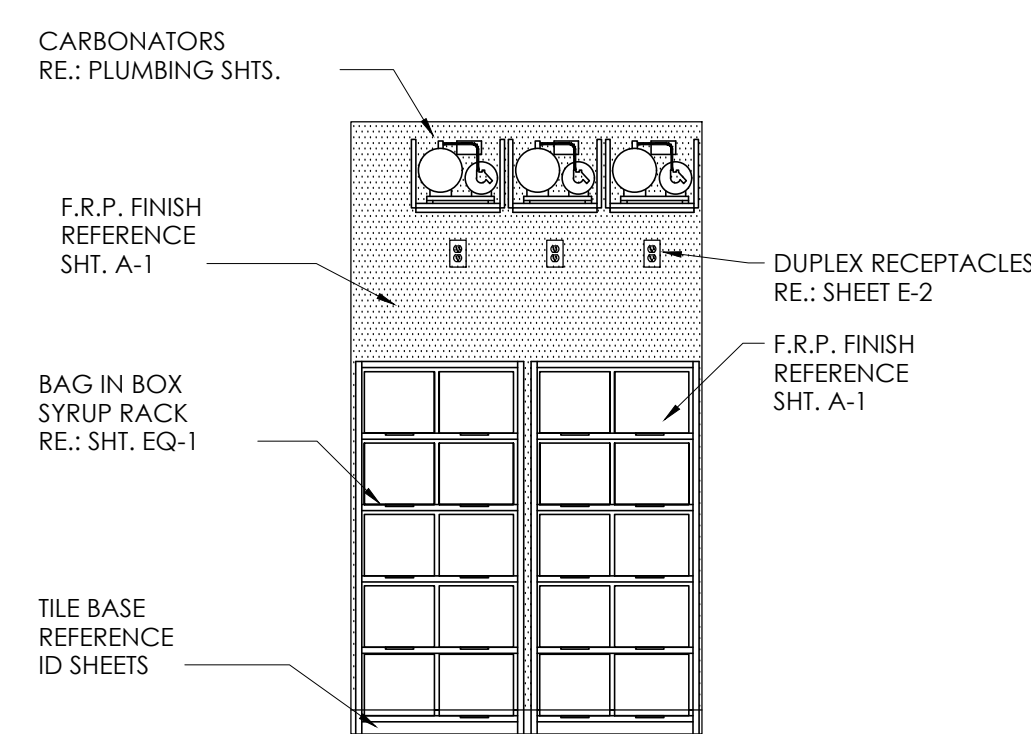

**C** ELEVATION  
SCALE: 3/8" = 1'-0"

No.	Date	By	Notes
3	5/26/21	DB	PLANNING SUBMITTAL
4	7/27/21	DB	BUILDING SUBMITTAL
5	8/27/21	AS	BUILDING REVISIONS
6	10/29/21	AS	ENGINEERING REVISIONS
7	12/10/21	AS	BUILDING REVISIONS 2

Drawn By: CP  
Checked: SB  
Scale: AS NOTED  
Date: 03.24.21

ALL RIGHTS RESERVED. NO PART OF THESE DRAWINGS OR SPECIFICATIONS MAY BE COPIED, REPRODUCED OR USED IN CONNECTION WITH ANY WORK OTHER THAN THE SPECIFIC PROJECT FOR WHICH THEY HAVE BEEN PREPARED, WITHOUT PRIOR WRITTEN AUTHORIZATION FROM THE ARCHITECT.

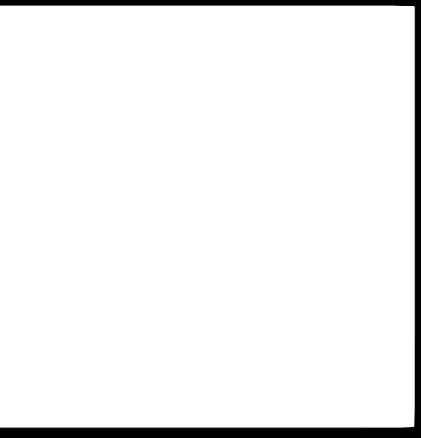
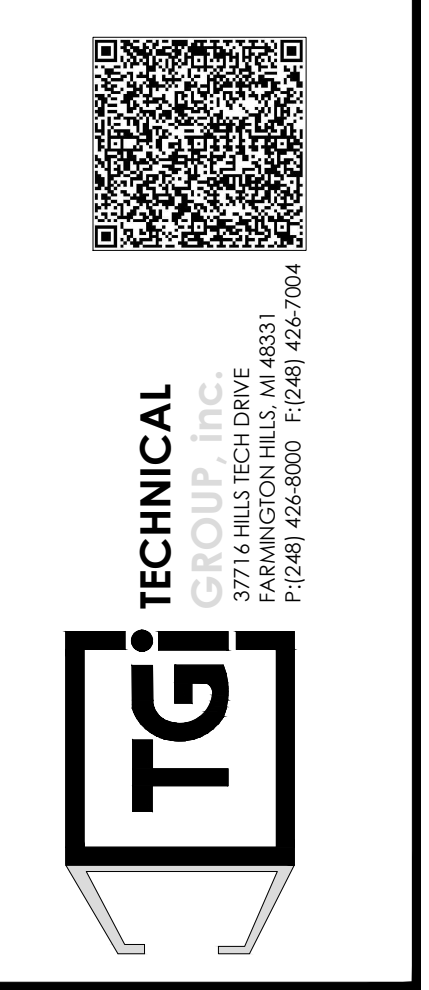

PROJECT BURGER KING #29300 - PORT RD. GRAVE CITY, OH 43024	SHEET TITLE MISCELLANEOUS DETAILS
DO NOT SCALE THIS PRINT. USE FIGURED DIMENSIONS ONLY.	
JOB # TG-21657	
SHEET A-1.1	