

ARCHITECTURE
ENGINEERING

LIS
LAND INVESTMENT SERVICES, LLC
ARR8913 CA NO. 29005
2577 West State Road 436
Suite 205A, Ocala, FL 32765
Phone: (352) 244-9402
Facsimile: (352) 244-9419

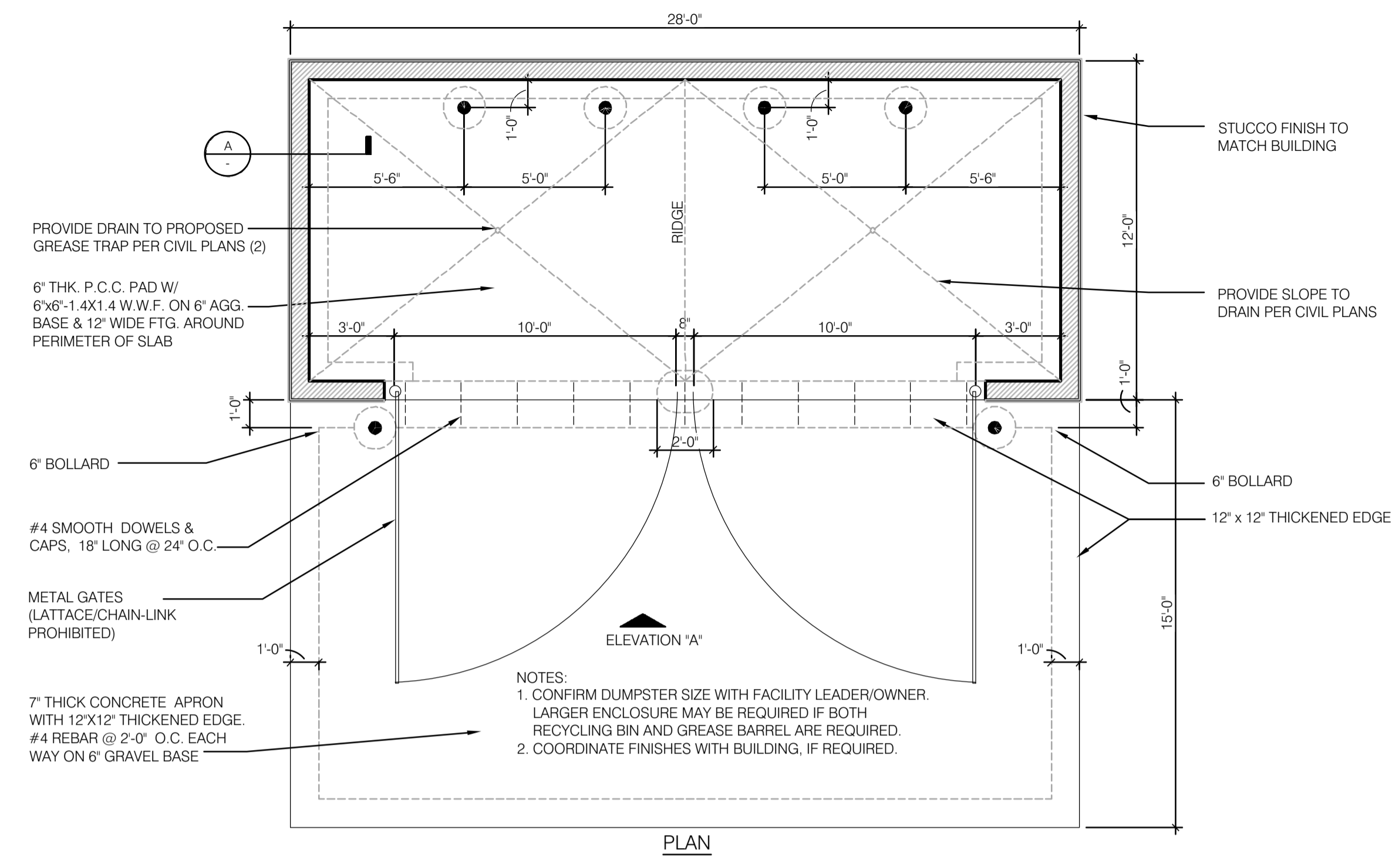
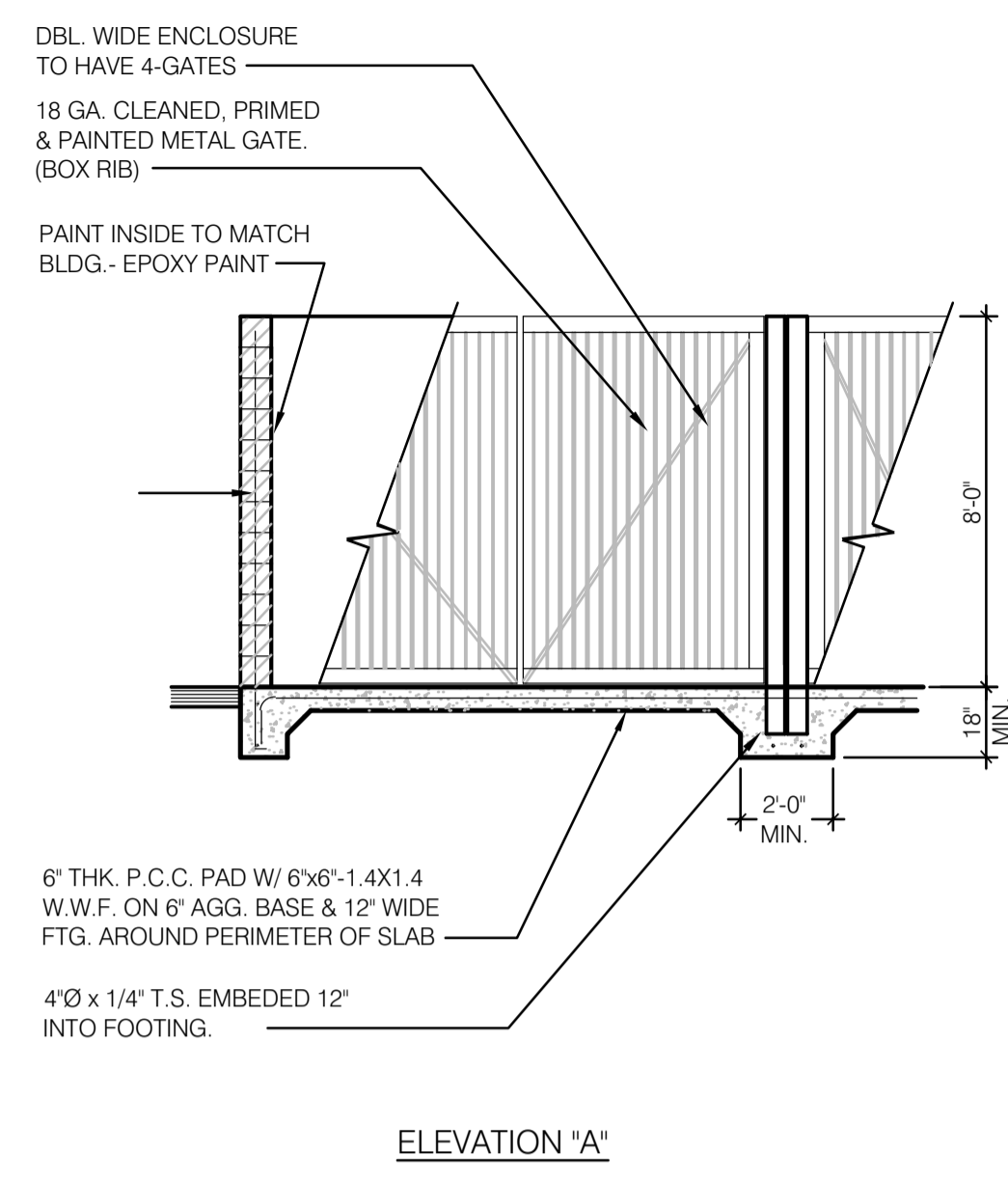

DUMPSTER ENCLOSURE PLAN AND ELEVATIONS 1/4" = 1'-0" **1**

Digitally signed by
ROBERT W CASE
Date: 2022.12.02 09:22:41 -05'00'
ROBERT WAYNE CASE
FLORIDA PE. #44643

PLAN SET REVISIONS:

CONTRACT DATE: ...-2019
BUILDING TYPE: Kb 30-19
PLAN VERSION: 2018.A
SITE NUMBER:
ENTITY NUMBER:
STORE NUMBER:
LIS PROJECT: 2019-304

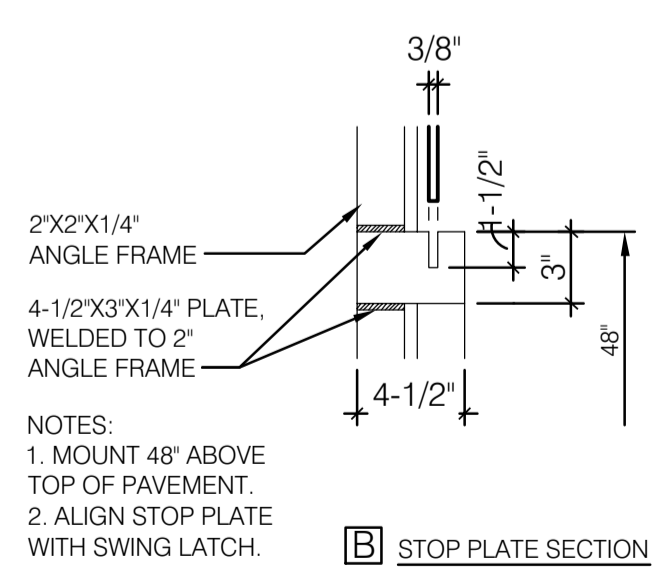
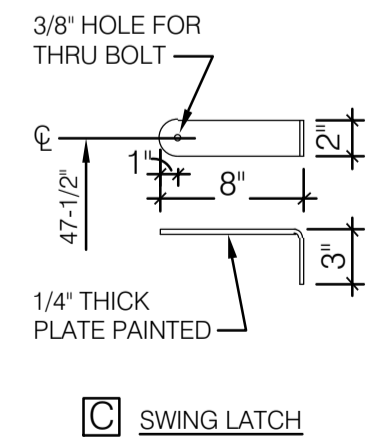
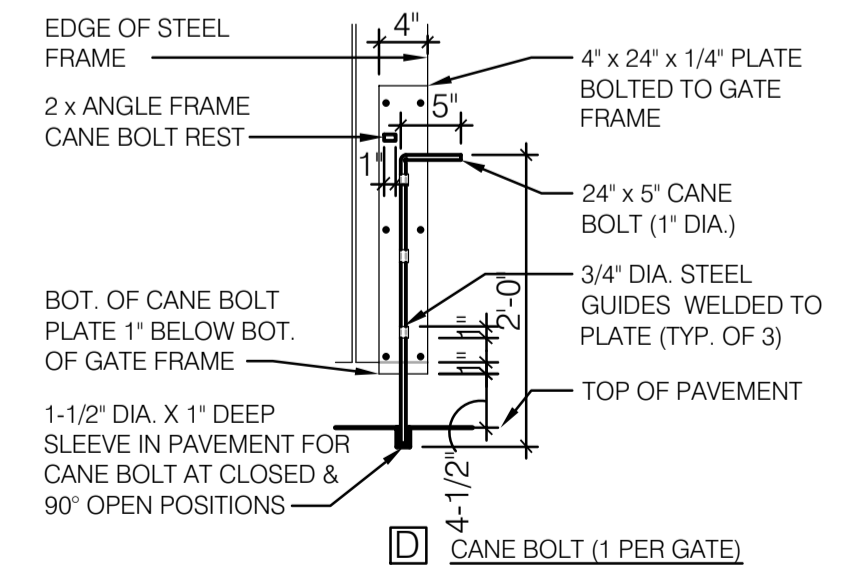
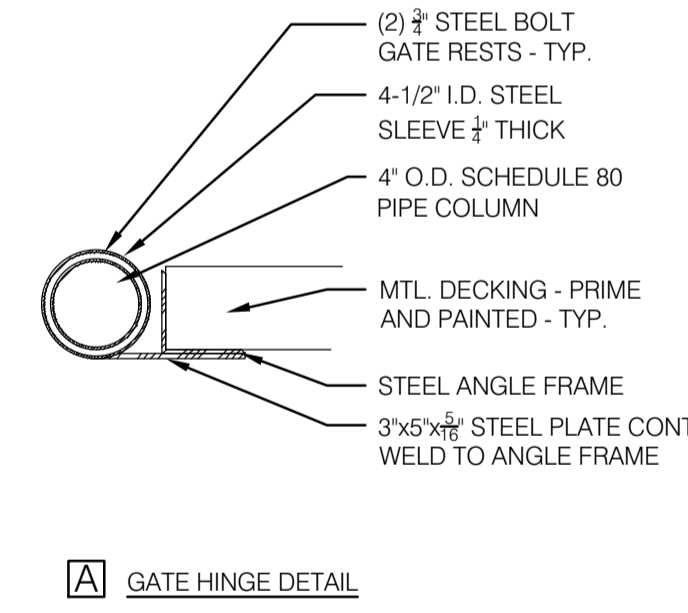
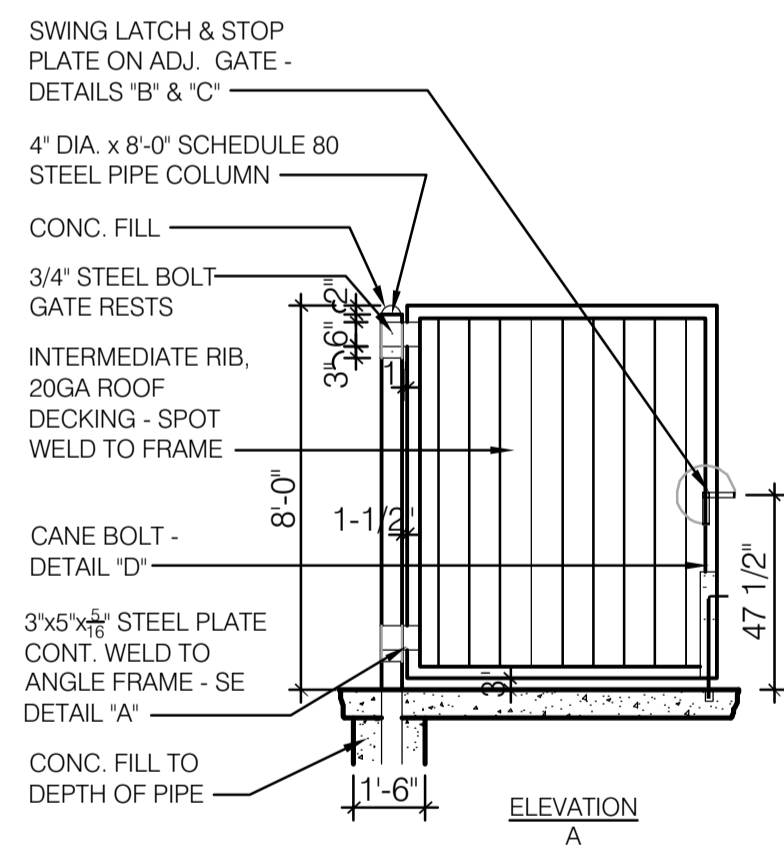
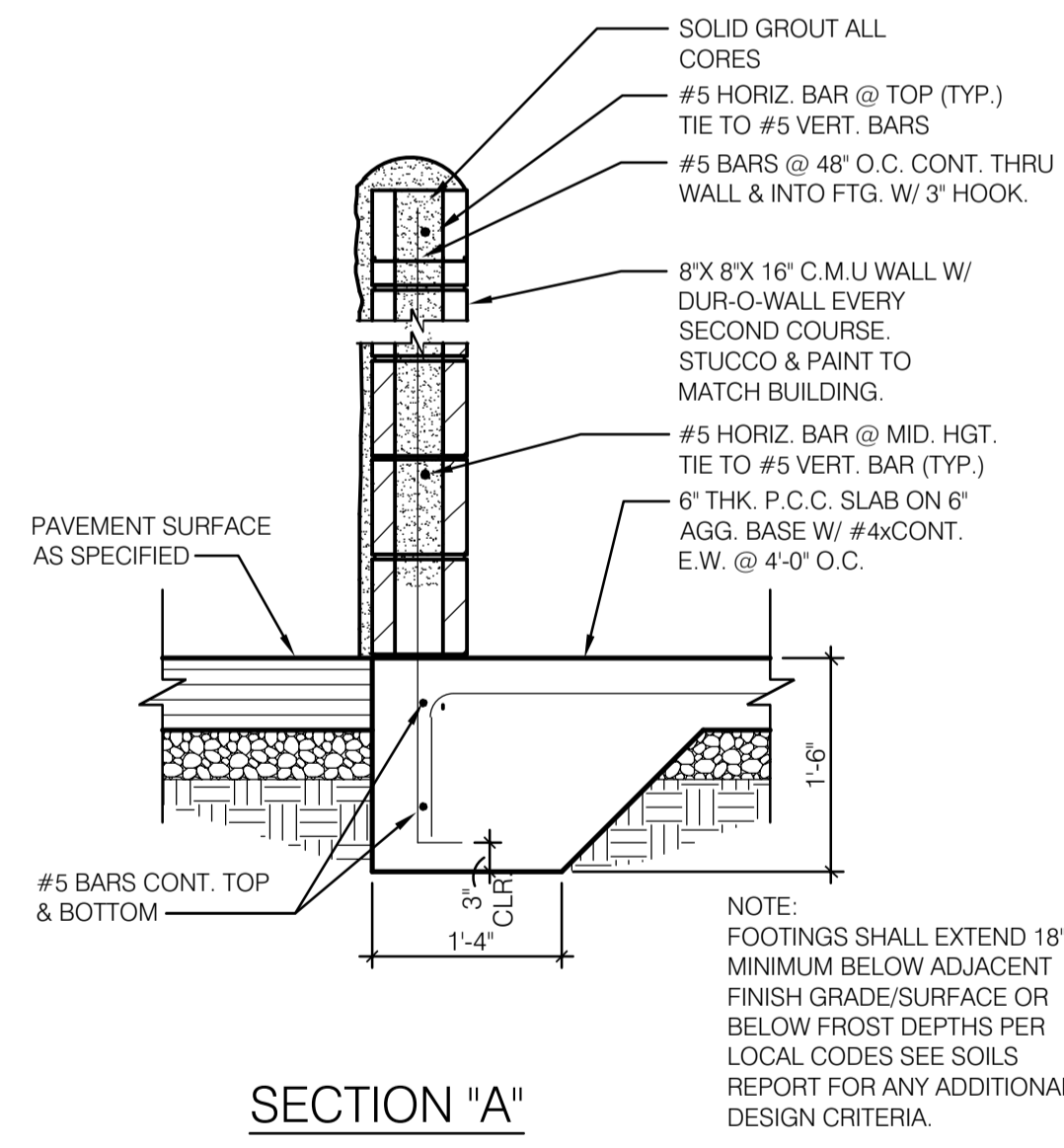
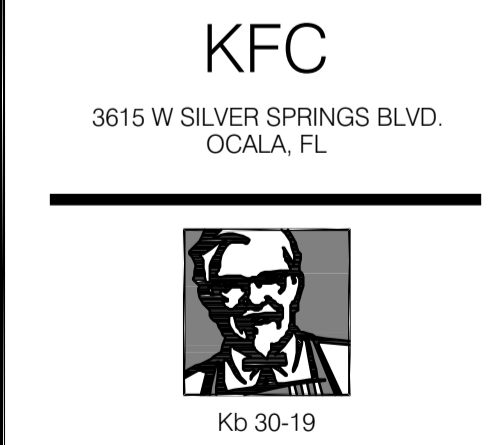

NOTES:
1. MOUNT 48" ABOVE TOP OF PAVEMENT.
2. ALIGN STOP PLATE WITH SWING LATCH.

DUMPSTER ENCLOSURE DETAILS **2**

DUMPSTER PLAN/DETAIL
C1.0

PLOT DATE: 03/29/2022