

ELEVATION "A"

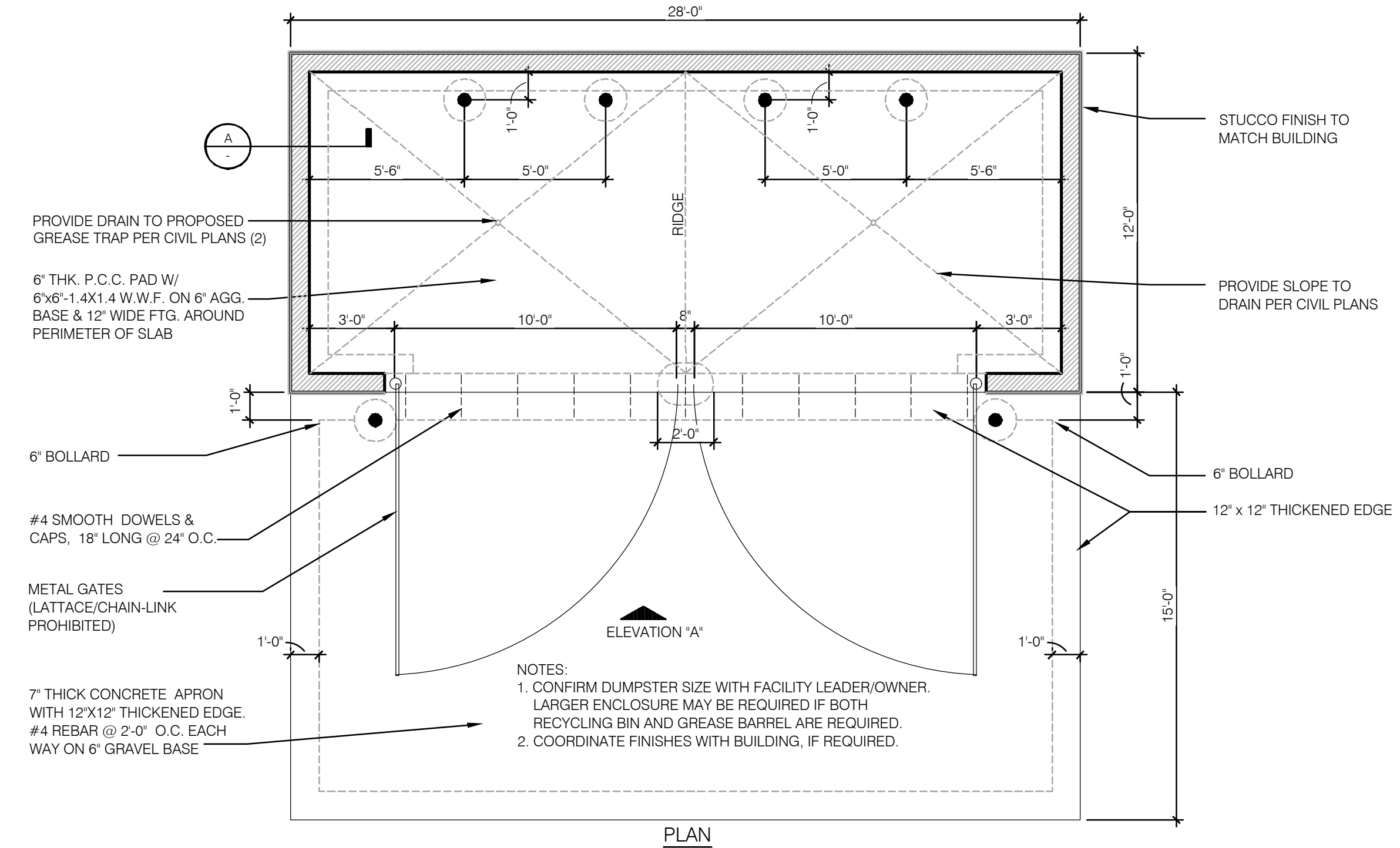

PLAN

DUMPSTER ENCLOSURE PLAN AND ELEVATIONS 1/4" = 1'-0" 1

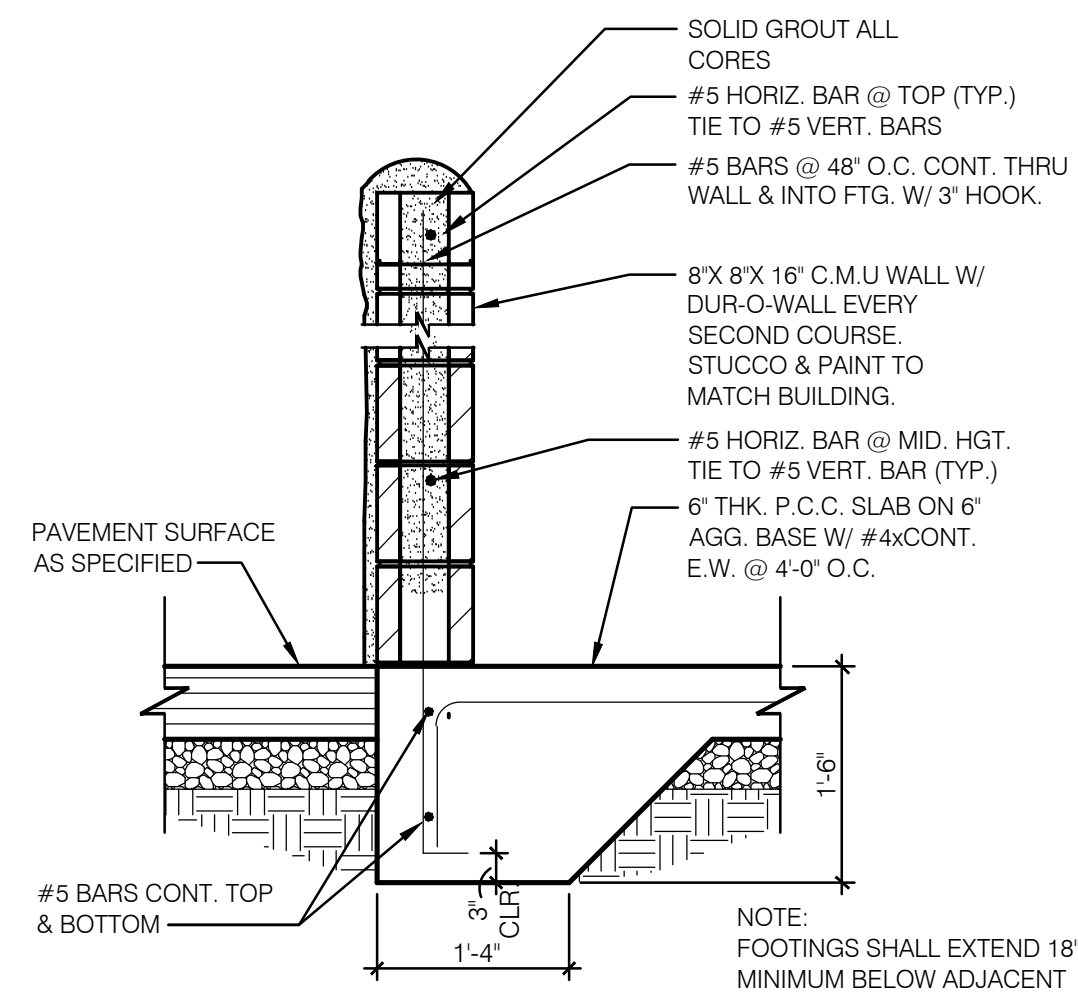

SECTION "A"

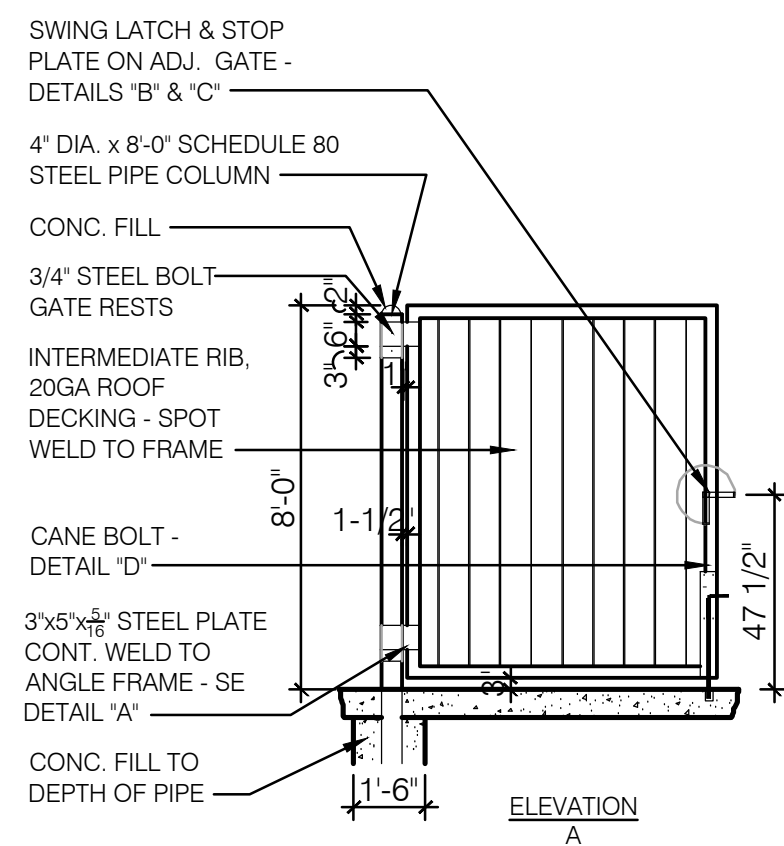

ELEVATION "A"

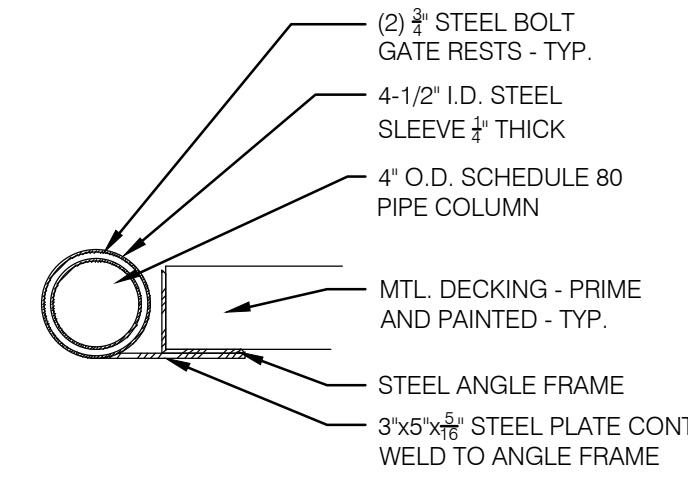

A GATE HINGE DETAIL

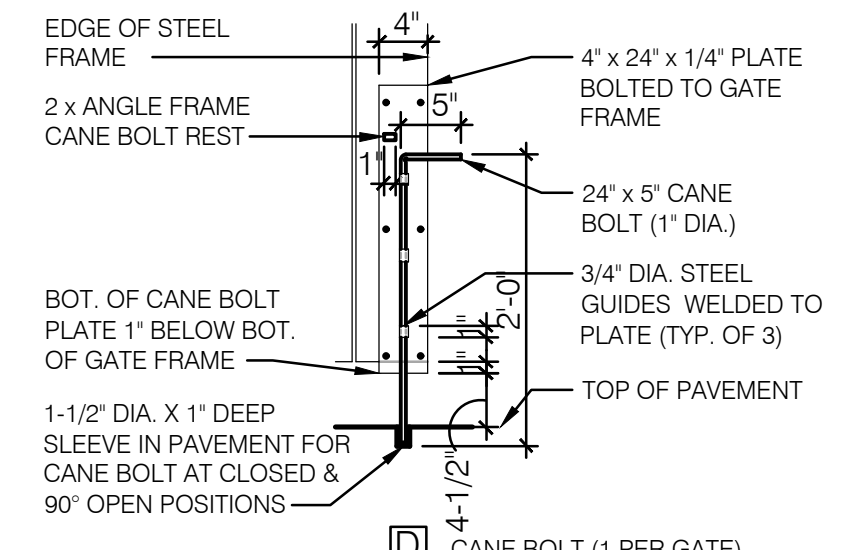

D CANE BOLT (1 PER GATE)

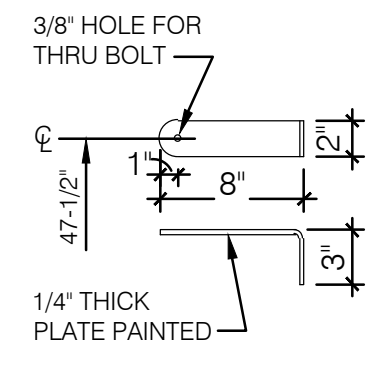

C SWING LATCH

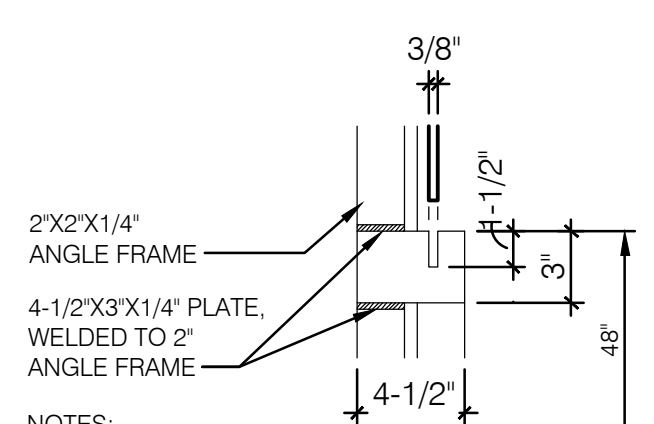

B STOP PLATE SECTION

NOTE: FOOTINGS SHALL EXTEND 18" MINIMUM BELOW ADJACENT FINISH GRADE/SURFACE OR BELOW FROST DEPTHS PER LOCAL CODES SEE SOILS REPORT FOR ANY ADDITIONAL DESIGN CRITERIA.

CA NO. 6853
21430 Palm Beach Blvd
Suite 100, Ft. Lauderdale, FL 33324
Phone: (239) 658-9244
Facsimile: (239) 658-9828

ARCHITECTURE
ENGINEERING

LIS
LAND INVESTMENT SERVICES, LLC
AR88913 CA NO. 28005
2577 West State Road 426
Suite 205A, Ocala, FL 32765
Phone: (321) 244-4002
Facsimile: (321) 244-9419

Digitally signed by
ROBERT W CASE
Date: **2022.12.02 09:22:41 -05'00'**

ROBERT WAYNE CASE
FLORIDA PE. #44643

PLAN SET REVISIONS:

| | |
|--|--|
| | |
| | |
| | |
| | |
| | |
| | |
| | |
| | |
| | |
| | |
| | |

CONTRACT DATE: ...-2019
BUILDING TYPE: Kb 30-19
PLAN VERSION: 2018.A
SITE NUMBER:
ENTITY NUMBER:
STORE NUMBER:
LIS PROJECT: 2019-304

KFC
3615 W SILVER SPRINGS BLVD.
OCALA, FL



DUMPSTER PLAN/DETAIL

C1.0