

TYPICAL SAMPLE POINT

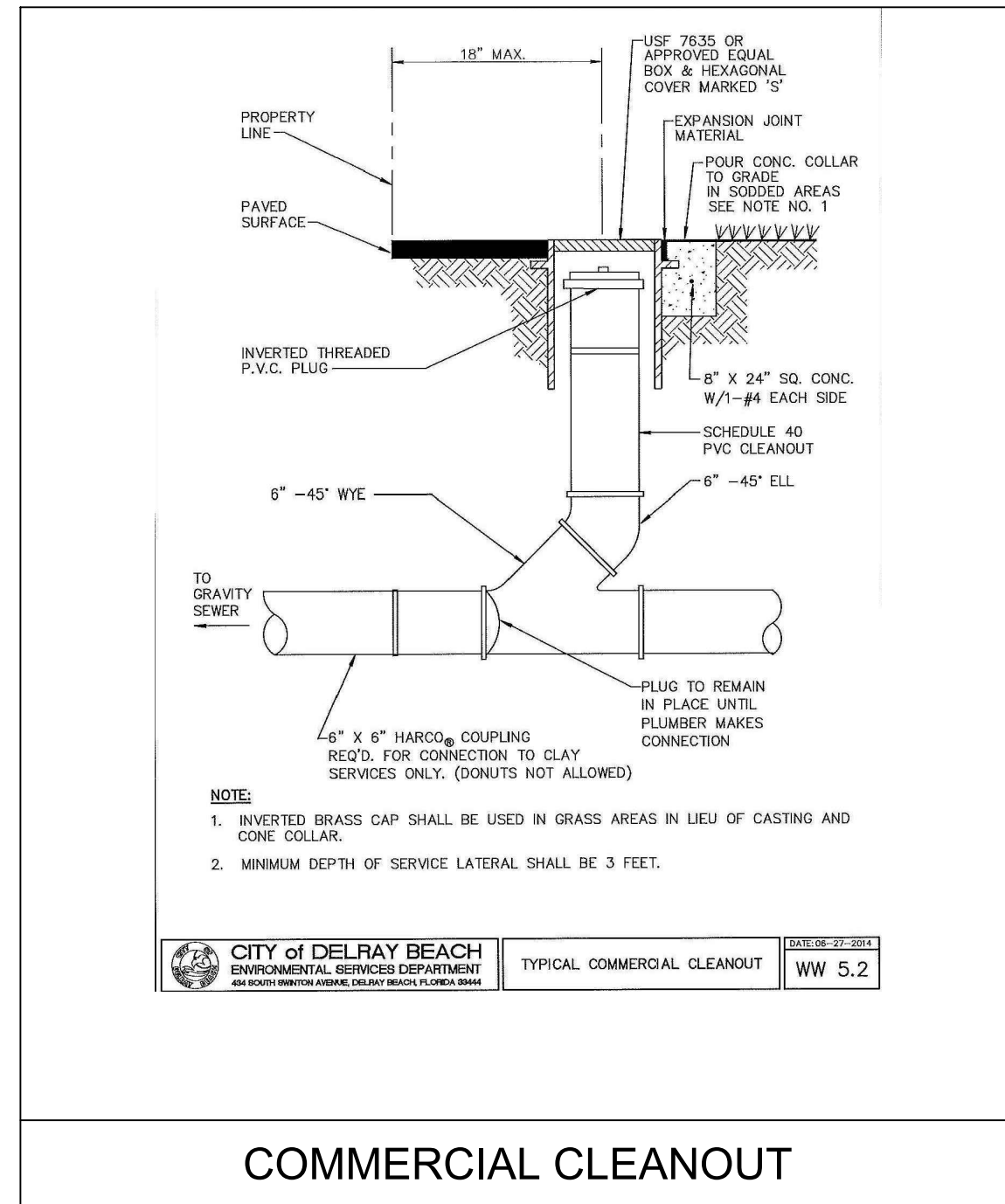

COMMERCIAL CLEANOUT

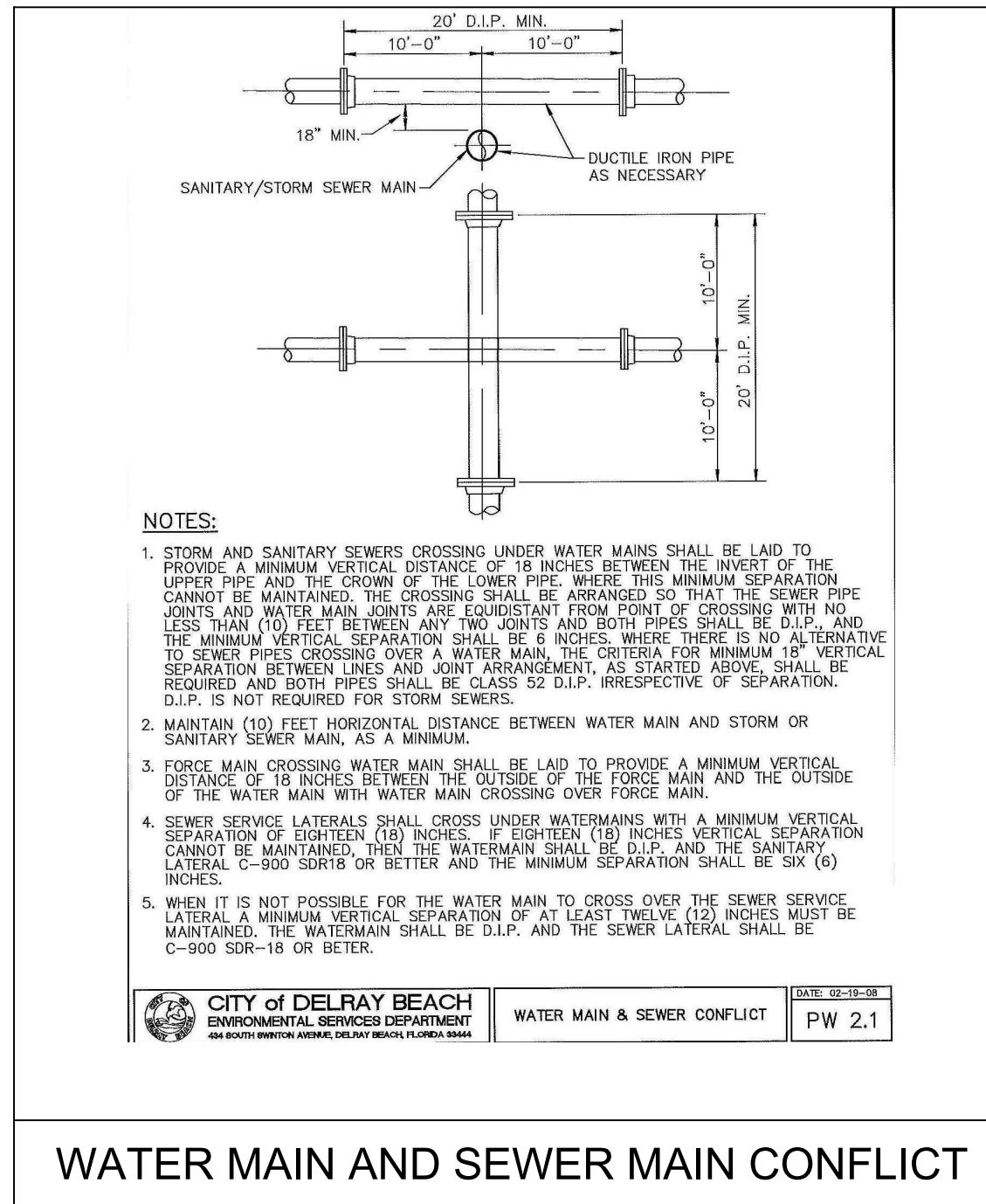

WATER MAIN AND SEWER MAIN CONFLICT

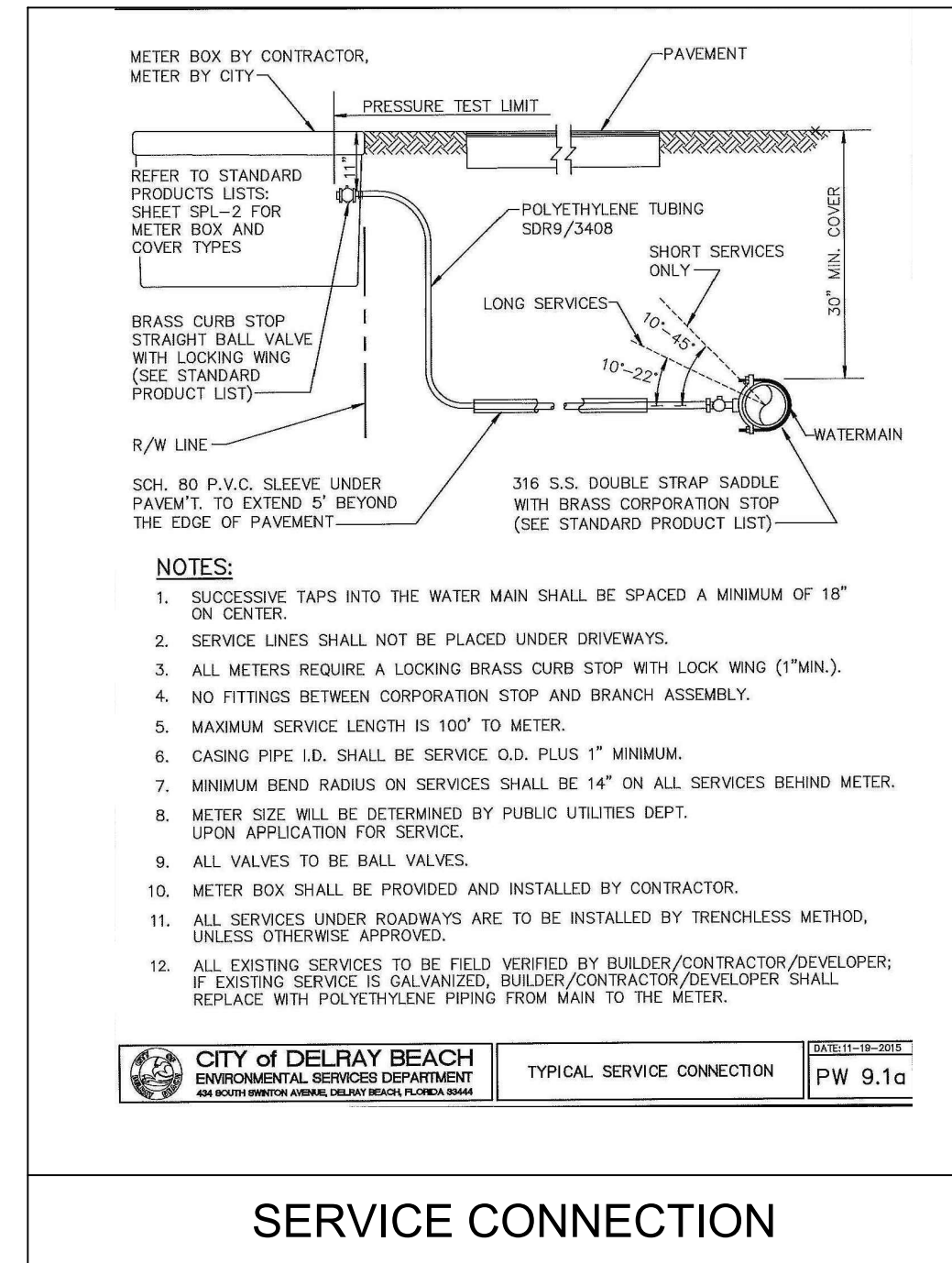

SERVICE CONNECTION

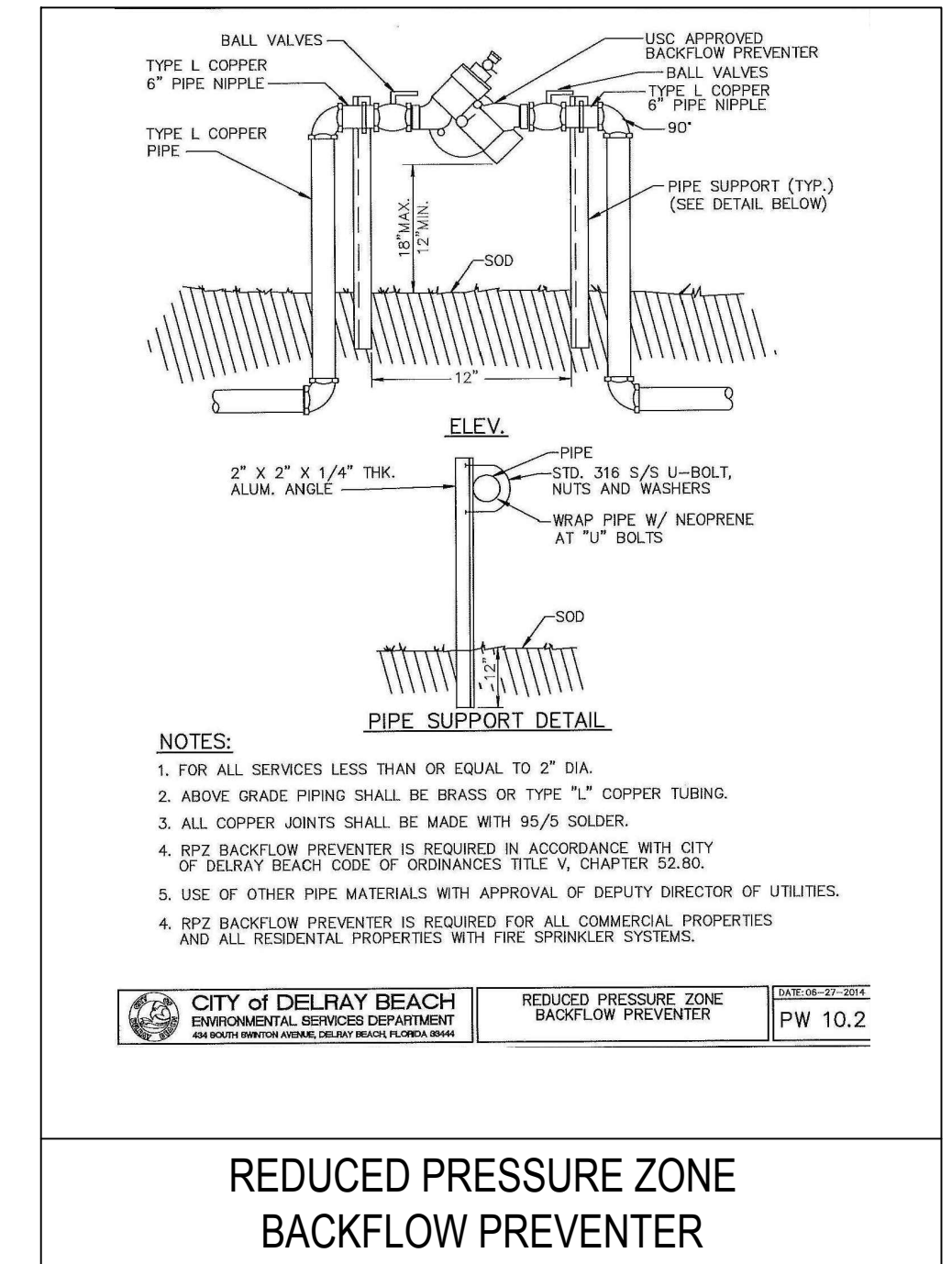

REDUCED PRESSURE ZONE BACKFLOW PREVENTER

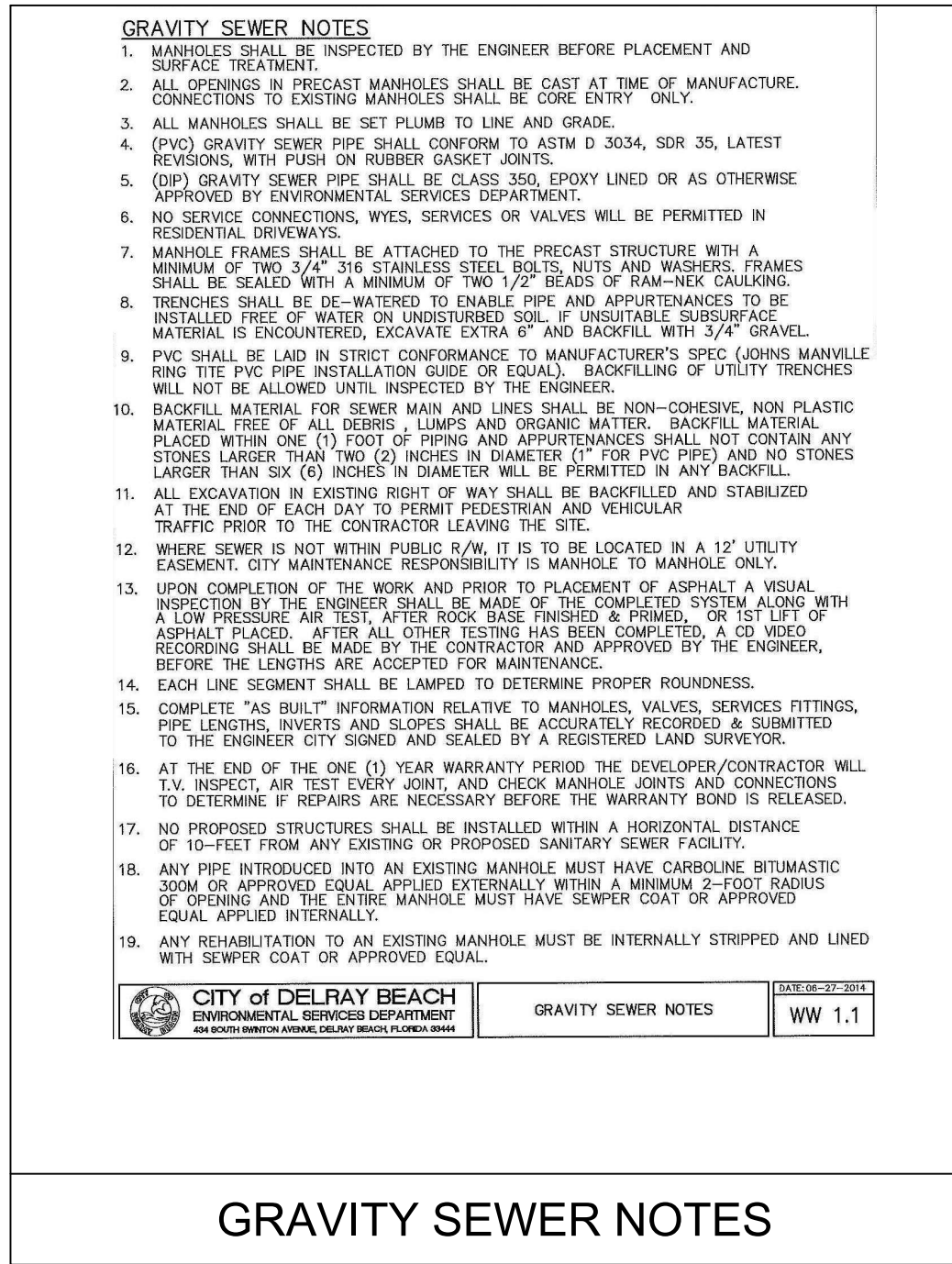

GRAVITY SEWER NOTES

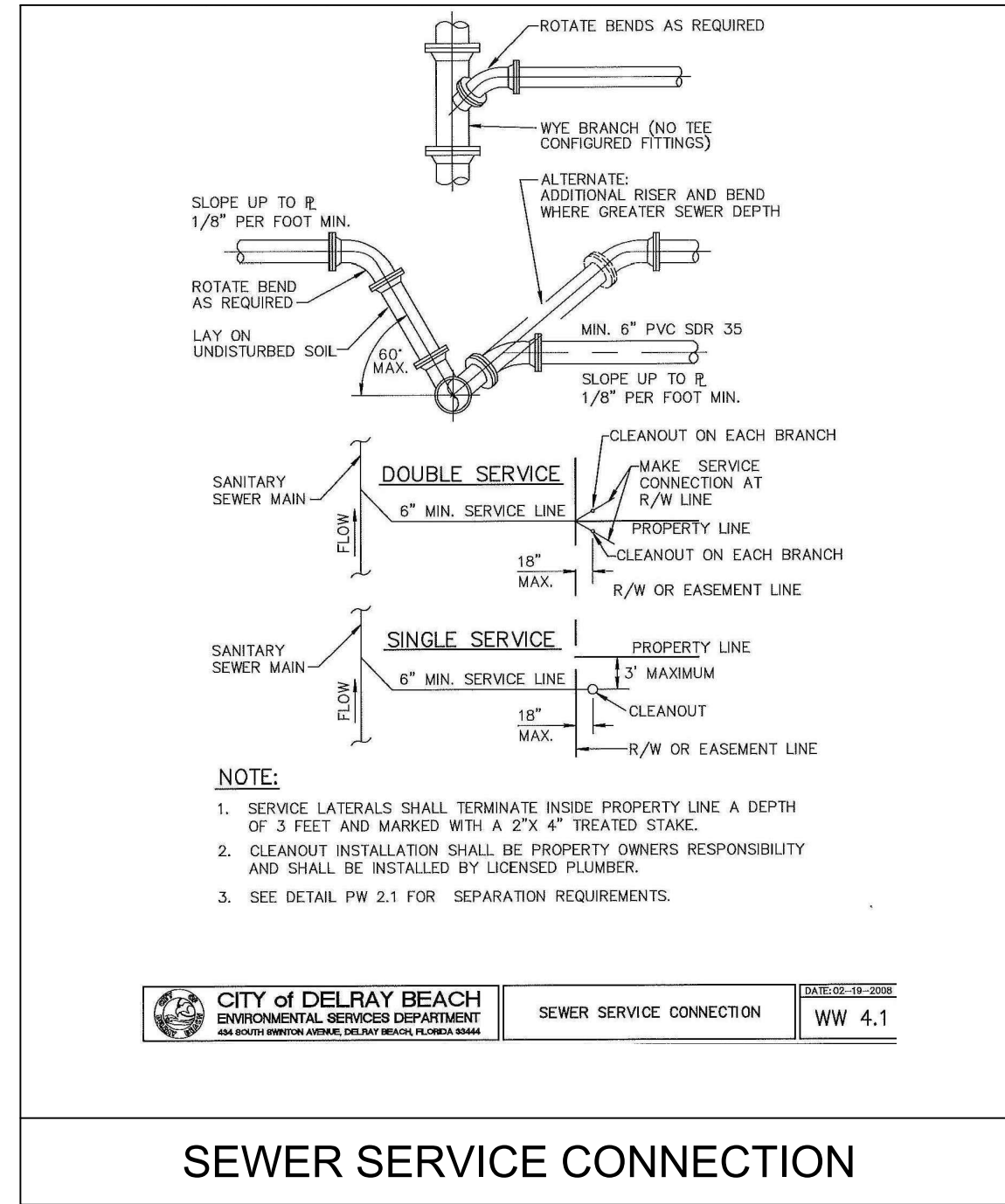

SEWER SERVICE CONNECTION

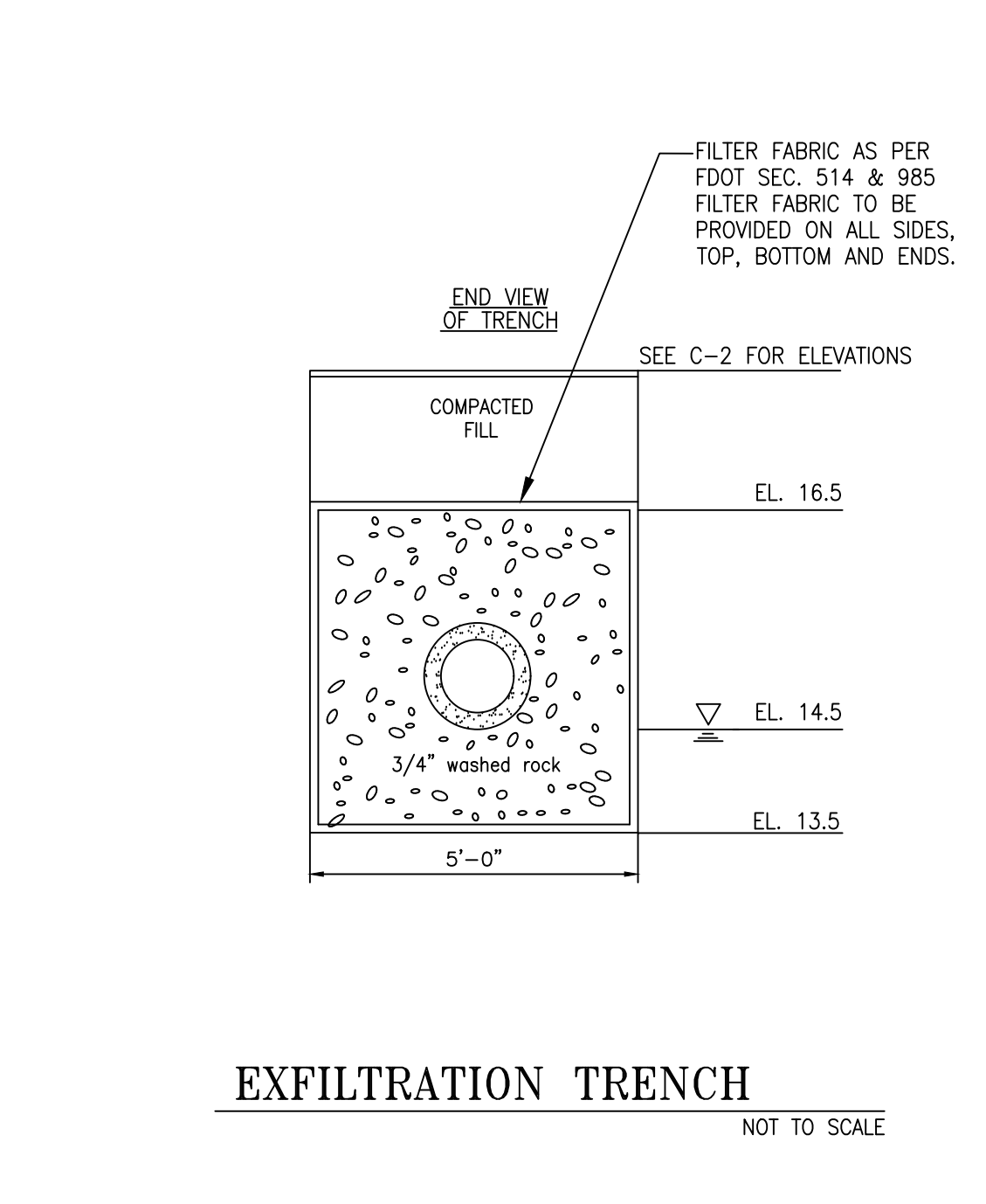

EXFILTRATION TRENCH

NOT TO SCALE

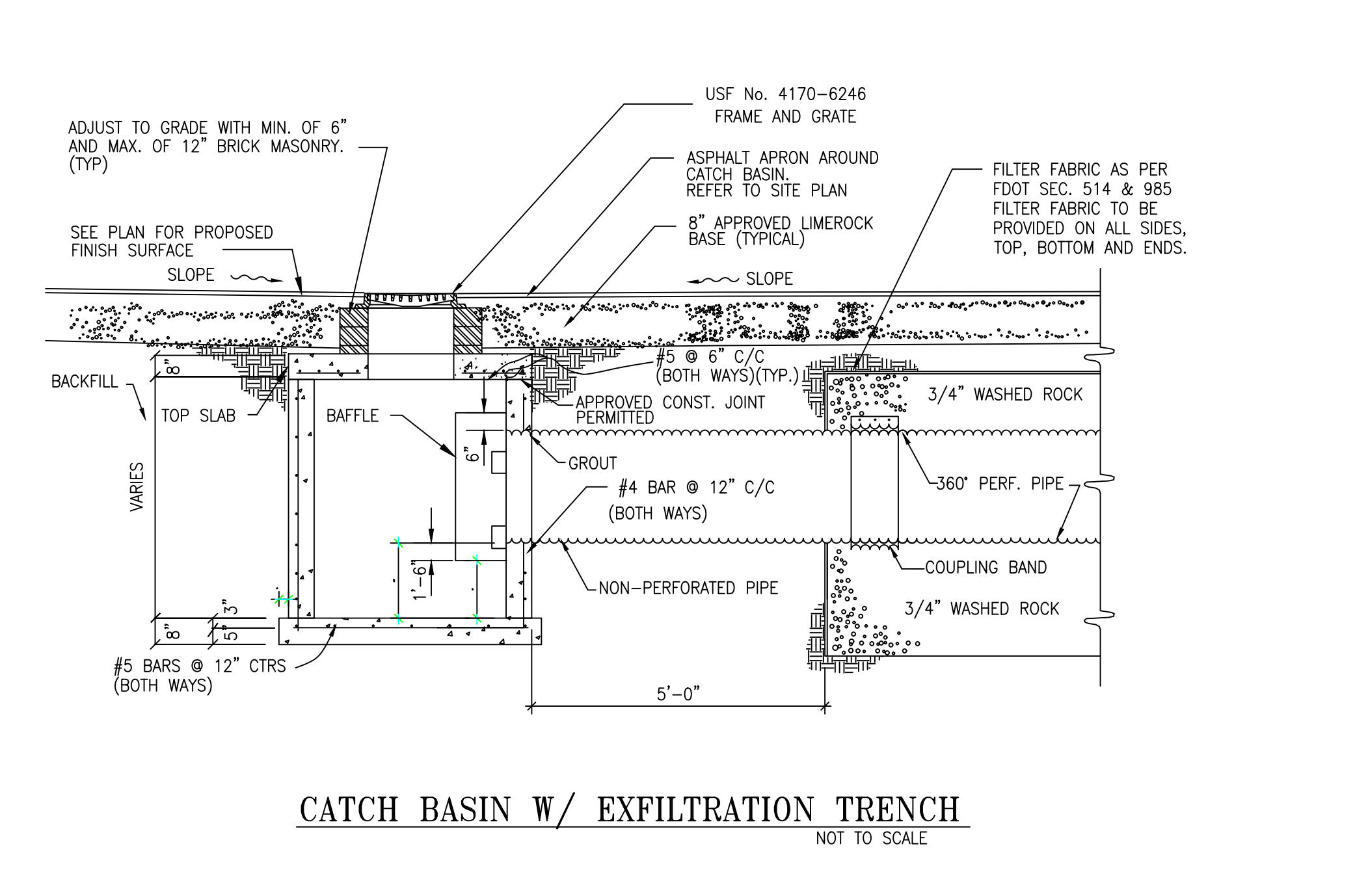

CATCH BASIN W/ EXFILTRATION TRENCH

NOT TO SCALE

GROUP

CKE GROUP
INCORPORATED
engineering • architecture • planning

15500 NEW BARN ROAD
SUITE 106
MIAMI LAKES, FLORIDA 33014

PHONE: (305) 558-4124
FAX: (305) 826-0619
EB#0004432

SEAL

EDUARDO L. CARCACHÉ
CIVIL ENGINEER-PE 31914
ANA A. GONZALEZ VALDEZ
ARCHITECT-AR 97769

NO.	DATE	DESCRIPTION
1	03-02-18	
2		
3		
4		
5		
6		
7		
8		
9		
10		

CONTRACT DATE:	-----
BUILDING TYPE:	CUSTOM
PLAN VERSION:	1
SITE NUMBER:	309797
STORE NUMBER:	420630

TACO BELL
5070 W. Atlantic Blvd.
Delray Bch., FL

TACO BELL

T-40
OPEN KITCHEN
DELRAY BEACH SOL
CONSTRUCTION
DETAILS

CD-4

PLOT DATE: 07-26-2018