

# SV24

## Sewer Viewer™ Wastewater Sampling Port Technical Data

Submittal | Special Precautions | Specifications | Installation

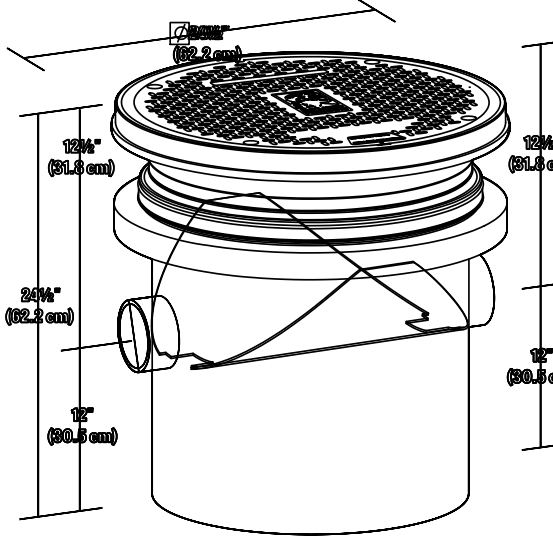

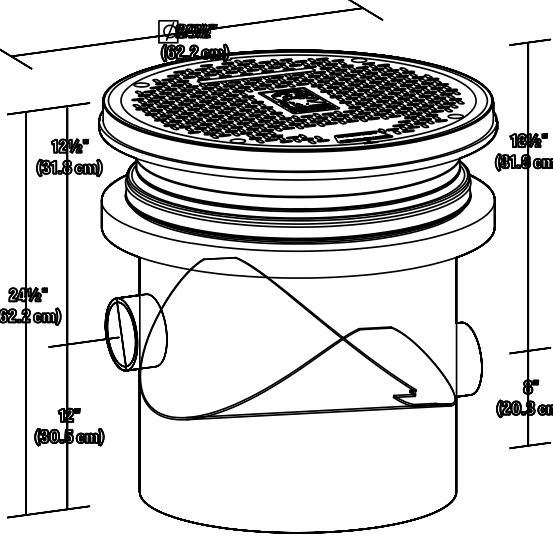

**SV24-L**                      **SV24-O**

### SUBMITTAL

**STANDARD:** 4" plain end inlet/outlet | Highway traffic load rated, bolted, gas/water tight composite covers. (16,000 lbs.)

<p><b>OPTIONS:</b></p> <ul style="list-style-type: none"> <li><input type="checkbox"/> 4" Level Connections</li> <li><input type="checkbox"/> 4" Offset Connections</li> <li><input type="checkbox"/> 48" 4" Male pipe thread connection</li> <li><input type="checkbox"/> 8" 6" Plain End SCH. 40 Inlet/Outlet</li> <li><input type="checkbox"/> 8" 6" Pedestrian rated cover (2,000 lbs.)</li> <li><input type="checkbox"/> 8" 6" H2O Load Rated Pickable Cast Iron Covers</li> </ul>	<p><b>Table 2: Rise Options</b></p> <ul style="list-style-type: none"> <li><input type="checkbox"/> LR24 (x) 4'-1/2" - 23"</li> <li><input type="checkbox"/> LR24 (x) 23" - 37'-3/4"</li> <li><input type="checkbox"/> SR24 (x) 37'-3/4" - 42'-1/2"</li> <li><input type="checkbox"/> SR24 (x) + LR24 (x) &gt;42'-1/2" - 57'-1/2"</li> <li><input type="checkbox"/> LR24 (x) &gt;57'-1/2" - 72"</li> </ul>	<p><b>APPROVAL:</b></p> <p>Signature: _____</p> <p>Date: _____</p> <p>Company: _____</p> <p>Specifying Engineer: _____</p> <p>Engineering Firm: _____</p>
-----------------------------------------------------------------------------------------------------------------------------------------------------------------------------------------------------------------------------------------------------------------------------------------------------------------------------------------------------------------------------------------------------------------------------------------------------------------------------------------	------------------------------------------------------------------------------------------------------------------------------------------------------------------------------------------------------------------------------------------------------------------------------------------------------------------------------------------------------------------------------------------------------------	-----------------------------------------------------------------------------------------------------------------------------------------------------------



**SCHIER**  
LIFETIME GUARANTEED  
GREASE INTERCEPTORS

8600 Woodland Road | Edwardsville, IL 62011 | Tel: 618-481-8800 | Fax: 618-481-8888 | www.schierproducts.com

**MODEL NUMBER:** SV24

**DESCRIPTION:** Polyethylene Wastewater Sampling Port

**PART #:** 8063-XXX-02    **DATE:** 2/25/2016    **REV:** 3 10/3/2017    **DOC:** 1067

**DATE:** 05/10/20

page 1 of 6

## SPECIAL PRECAUTIONS

For All Schier Grease Interceptor Installations

### Installation Instructions

Installation instructions and additional components are located inside the Interceptor. Read all instructions prior to installation. This interceptor is intended to be installed by a licensed plumber in conformance with all local codes.

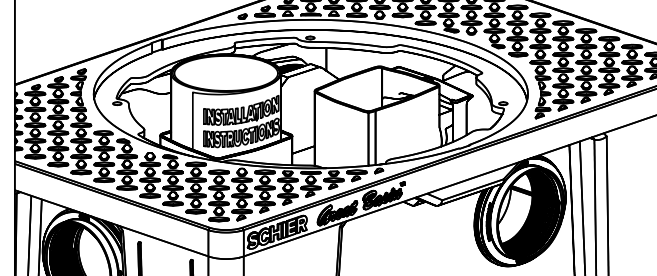

### When Installing Interceptor Inside

If your dishwashing sink(s) discharges into a floor drain (sink), you must regulate the flow into the drain to avoid an overflow of water onto the kitchen floor. This can be done by installing a valve or flow restriction cap on the sink piping that discharges into the drain. See drawing below for guidance. For detailed guidance on indirect connections, go to: [http://webtools.schierproducts.com/Technical\\_Data/Indirect\\_Connections.pdf](http://webtools.schierproducts.com/Technical_Data/Indirect_Connections.pdf)

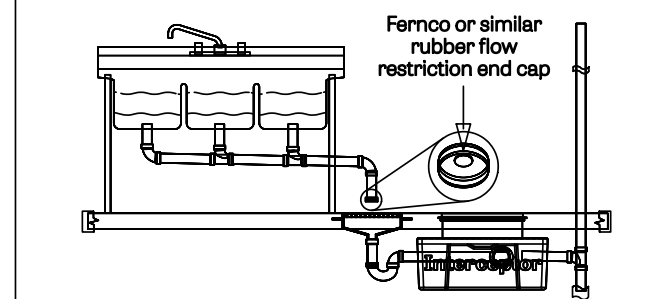

### High Temperature (Kitchen Water)

If water is entering the interceptor at excessive temperature (over 140° F), a drain water tempering valve (DWT) must be installed. Most state and local plumbing codes prohibit water above 140° F being discharged into the sanitary sewer. Water above 140° F will weaken or deform PVC Schedule 40 pipe, poly drainage features like interceptors and erode the coating of cast iron (leading to eventual failure). Failure to follow this guidance voids your warranty.

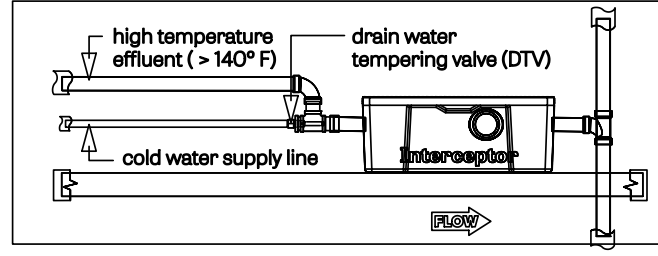

### High Water Table Installations

Interceptors and risers are not designed to withstand water table height in excess of the top of the unit when buried (see figure). If it is possible for this to occur, install the interceptor and riser in a water-tight concrete vault or backfill with concrete or flowable fill (wet concrete and flowable backfill should be poured in stages to avoid crushing the interceptor). At risk areas include but are not limited to tidal surge areas, floodplains and areas that receive storm water. Failure to follow this guidance voids your warranty. Models GB-50, GB-76, and GB-250 that are direct buried in high water table scenarios must be installed with model AK1 anchor kit or warranty is void.

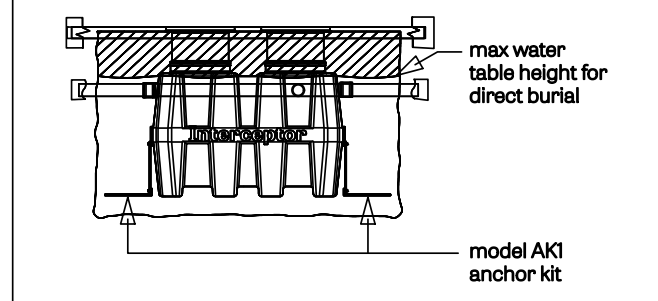

### Hydrostatic Slabs (or Pressure Slabs)

When installed under a hydrostatic slab (slab designed to withstand upward lift, usually caused by hydrostatic pressure) interceptor must be enclosed in a watertight concrete vault. Failure to follow this guidance voids your warranty.

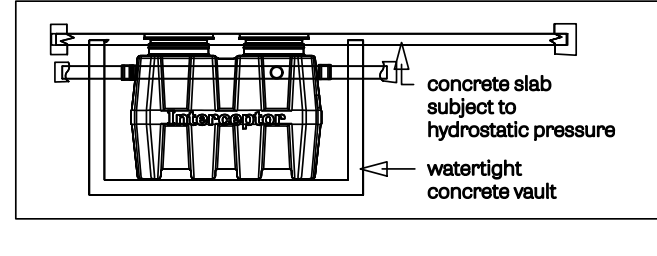



**SCHIER**  
LIFETIME GUARANTEED  
GREASE INTERCEPTORS

8600 Woodland Road | Edwardsville, IL 62011 | Tel: 618-481-8800 | Fax: 618-481-8888 | www.schierproducts.com

**MODEL NUMBER:** SV24

**DESCRIPTION:** Polyethylene Wastewater Sampling Port

**PART #:** 8063-XXX-02    **DATE:** 2/25/2016    **REV:** 3 10/3/2017    **DOC:** 1067

**DATE:** 05/10/20

page 2 of 6

## SPECIFICATIONS

**NOTES:**

- 4" plain end inlet/outlet
- Unit weight - 65 lbs.
- Unit supplied with built-in adapter for up to 3" of continuous adjustability. Additional riser(s) are also available for deeper burial depth.
- Maximum operating temperature: 140° F continuous

**ENGINEER SPECIFICATION GUIDE**

Schier Sewer Viewer™ sampling port model #SV24 shall be manufactured by Schier Products, Edwardsville, KS. Port shall be lifetime guaranteed and made in USA of seamless, rotationally molded polyethylene.

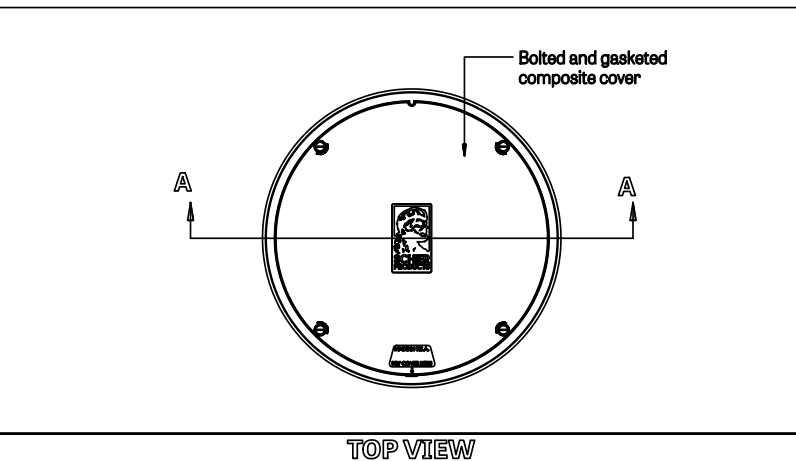
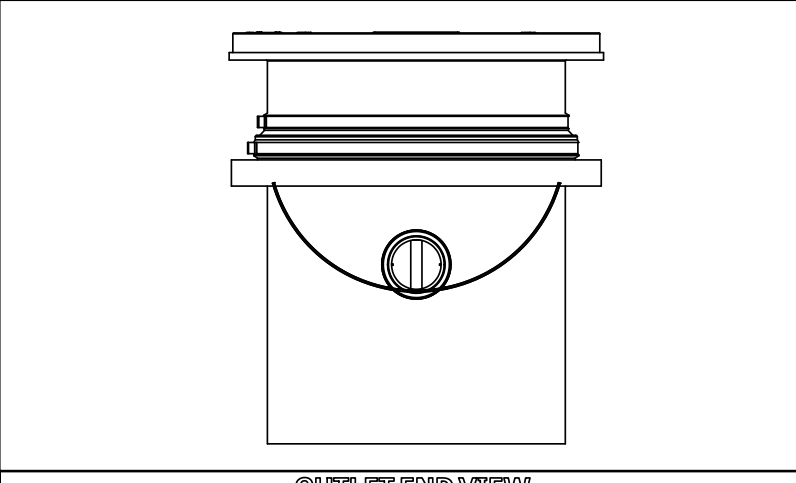

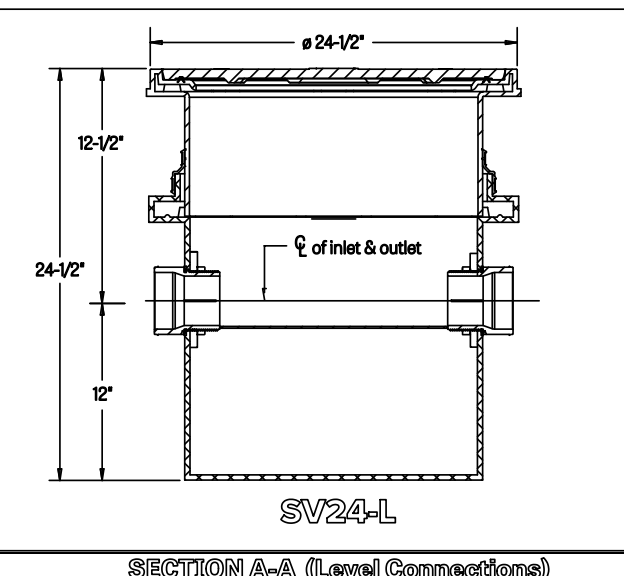
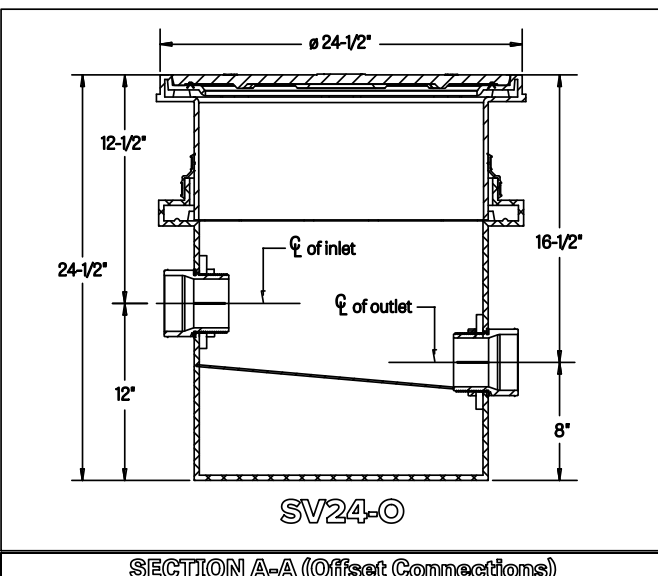
**SCHIER**  
LIFETIME GUARANTEED  
GREASE INTERCEPTORS

8600 Woodland Road | Edwardsville, IL 62011 | Tel: 618-481-8800 | Fax: 618-481-8888 | www.schierproducts.com

**MODEL NUMBER:** SV24

**DESCRIPTION:** Polyethylene Wastewater Sampling Port

**PART #:** 8063-XXX-02    **DATE:** 2/25/2016    **REV:** 3 10/3/2017    **DOC:** 1067

**DATE:** 05/10/20

page 3 of 6

## INSTALLATION (1 of 2)

**WARNING! DO NOT AIR TEST UNIT OR TELLERIDE RISER SYSTEM!** Doing so may result in property damage, personal injury or death.

### LEAK/SEAL TESTING

Cap/Plug all base unit plumbing connections and remove covers. For base unit testing, fill with water to just above the highest connection. For riser systems testing (if required) fill with water to finished grade level. **CAUTION:** Risers must be supported and backfill filling with water to prevent tipping. Inspect unit, connections and all gaskets and clamps (if applicable) for leaks. Check water level at specific time intervals per local code. **NOTE:** All telleride risers have been tested for leaks prior to shipment from the factory.

### EXCAVATION

- Install unit as close as possible to grease interceptor being served.
- Surrounding soil must be undisturbed soil or well compacted engineering fill.
- Measure the width and length of the tank and excavate a hole that is a minimum of 12" greater than the tank on all sides and 6" deeper than tank bottom.
- After the excavation is complete create a well compacted support layer of sand-gravel mixture to the ground supporting tank is a minimum of 6" above native soil.

### BELOW GRADE UNIT INSTALLATION

- Lower and center the unit into hole using straps around unit. Do not use chains or accessories to move the unit.
- Ensure the unit tops are level with finished grade.
- All pipe penetrations to be sleeved or have slip connections.
- Fill unit with water before backfilling to stabilize unit and prevent float-out during backfilling.

### BACKFILLING AND FINISHED CONCRETE SLAB

- Before backfilling and pouring of slab, secure covers and risers (if necessary) to the unit.
- Backfill evenly around tank using crushed aggregate (approximately 3/4" size rock or sand with no fines), or flowable fill. Work backfill under the unit using a probe to ensure the unit is fully supported.
- Thickness of concrete around cover to be determined by specifying engineer. If traffic loading is required the concrete slab dimensions shown are for guideline purposes only. Concrete to be 28 day compressive strength to 4000 PSI. Slab must extend 18" outside the unit footprint.
- NO. 4 rebar (1/2" grade 60 steel per ASTM A615; connected with tie wire. Rebar to be 2-1/2" from edge of concrete and spaced in a 12" grid with 4" spacing around access openings.

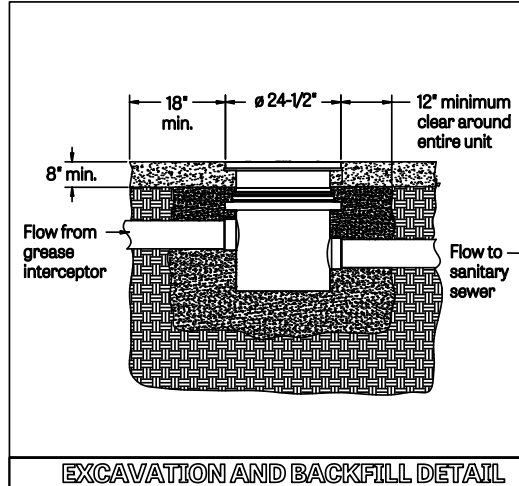

**EXCAVATION AND BACKFILL DETAIL**

### ABOVE GRADE INSTALLATION

- Set unit on a solid and level surface.
- If unit is to be suspended above the floor ensure bottom of unit is fully supported.
- Connect waste piping to the unit.
- To conduct a pressure test on pipes, if required, use expendable test plug. Do not pressure test unit.

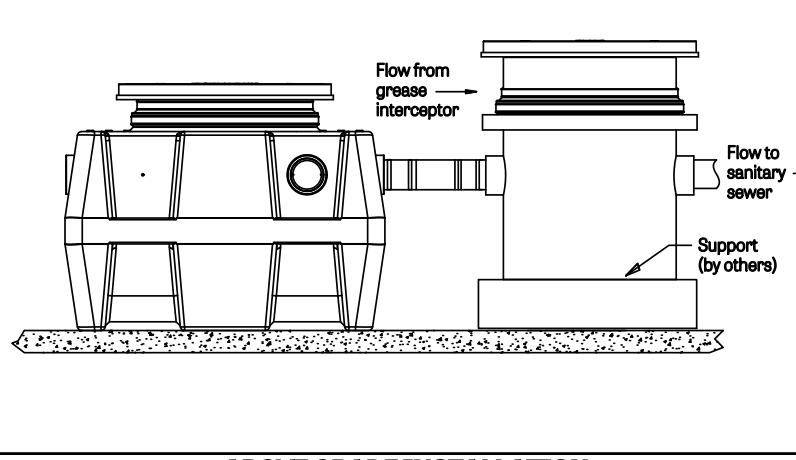

**ABOVE GRADE INSTALLATION**



**SCHIER**  
LIFETIME GUARANTEED  
GREASE INTERCEPTORS

8600 Woodland Road | Edwardsville, IL 62011 | Tel: 618-481-8800 | Fax: 618-481-8888 | www.schierproducts.com

**MODEL NUMBER:** SV24

**DESCRIPTION:** Polyethylene Wastewater Sampling Port

**PART #:** 8063-XXX-02    **DATE:** 2/25/2016    **REV:** 3 10/3/2017    **DOC:** 1067

**DATE:** 05/10/20

page 4 of 6

## INSTALLATION (2 of 2)

### TELLERIDE RISER (24 SERIES) INSTALLATION GUIDELINES

Tools needed: 7/16" Nut driver tool/bit (included), marker (included), tape measure and drill with 1/2" chuck, 1/4" diameter circular saw or reciprocating saw will be needed if riser(s) will be cut.

**NOTE:** To remove a component or adjust its position, the Upper Band Clamp needs to be loosened or removed using nut driver bit. Loosened clamps should be re-tightened to 5-8 lbs. of torque (same as a rubber no-hub coupling). The Lower Band Clamp is factory set and should not be adjusted or removed.

### Riser Assembly Instructions/Steps

- Set unit so the pipe connections line up with job site piping and measure riser height needed from top of cover to finished grade. See Table 1 to select risers needed.
- Remove covers from adapters. Remove adapters from main unit. On a level surface, pre-assemble the risers and adapters, adjusting the components upwards or downwards to achieve the riser height needed. Make sure to maintain minimum and maximum insertion depths as shown in Figure 2. If components are too long, make a circular line around the sidewall with marker and cut with a power saw. The lowest cut line on the riser assembly will be 6" beyond the riser height needed to allow for ideal insertion depth (See Figure 1). An alignment mark should be drawn 2" beyond the riser height needed that will align with the top of the base unit gasket. DO NOT cut the alignment mark. The Adapters and risers should all level with each other. Tighten upper clamps to keep riser/adapter assembly from shifting. Make alignment marks on the sidewalls at the top of all riser gaskets to aid final assembly.
- IMPORTANT:** Before the next step, make sure both diffusers are installed inside the main unit at the appropriate locations. Check if there needs to be any flow control adjustment at the inlet diffuser (see general installation instructions).
- Take apart riser assembly and clean all sidewalls and insides of gaskets to remove dust/debris. Install components into the main unit starting from the lowest riser and work your way up to finished grade. Maintain minimum and maximum insertion depths for all components (see Figure 2). Tighten Upper Clamps to specified torque after correctly positioning components. Riser assembly may need to be supported during backfill.
- If tilting of the adapter is required to be flush with grade, do so AFTER all clamps have been tightened with riser(s)/adapter in a vertical and level position. Tilting is done using gasket flexibility. Tilting before tightening clamps may ruin a perfect gasket seal. Schier recommends tilting only the adapter versus the entire riser assembly to make sure your riser height and proper tank access is maintained.
- If riser height conditions change after completing above steps, there may be room for adjustment. As long as minimum and maximum insertion depths are maintained (see Figure 2), the adapters/risers can be adjusted/cut as many times as necessary. When riser system installation is complete, see Leak/Seal Testing procedure if required (pg 3 of 4).

Riser Height Needed	Risers Required
0' - 3"	None (use adapter)
4'-1/2" - 23"	SR24
>23" - 37'-3/4"	LR24
>37'-3/4" - 42'-1/2"	SR24 (x2)
>42'-1/2" - 57'-1/2"	SR24 + LR24
>57'-1/2" - 72"	LR24 (x2)

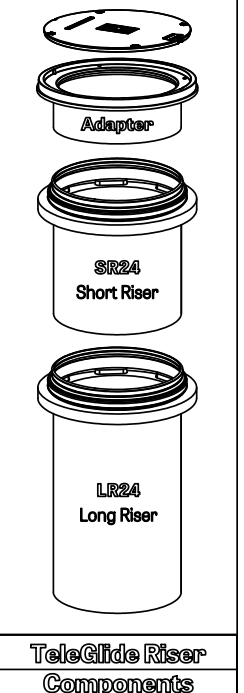

**Table 1 - Riser Measurements**

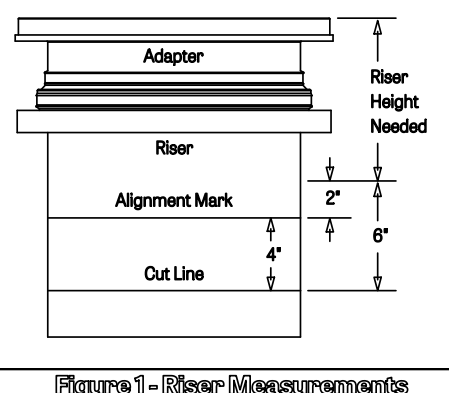

**Figure 1 - Riser Measurements**

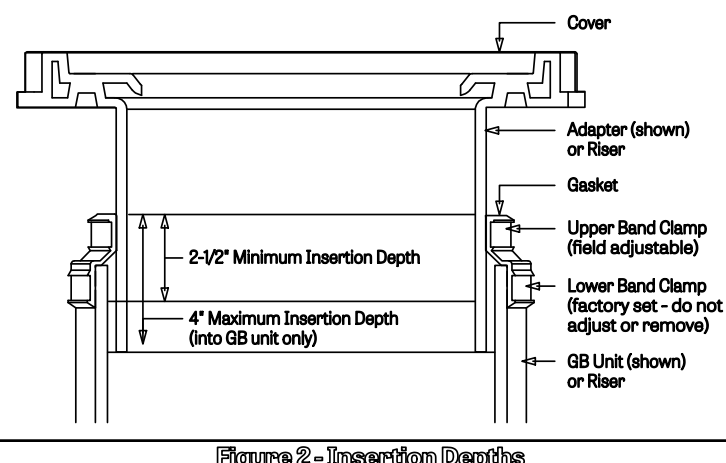

**Figure 2 - Insertion Depths**



**SCHIER**  
LIFETIME GUARANTEED  
GREASE INTERCEPTORS

8600 Woodland Road | Edwardsville, IL 62011 | Tel: 618-481-8800 | Fax: 618-481-8888 | www.schierproducts.com

**MODEL NUMBER:** SV24

**DESCRIPTION:** Polyethylene Wastewater Sampling Port

**PART #:** 8063-XXX-02    **DATE:** 2/25/2016    **REV:** 3 10/3/2017    **DOC:** 1067

**DATE:** 05/10/20

page 5 of 6

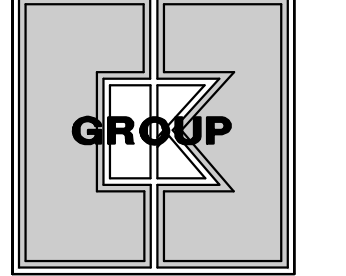

**CKE GROUP**  
INCORPORATED  
engineering • architecture • planning

15900 NEW BARN ROAD  
SUITE 106  
MIAMI LAKES, FLORIDA 33014

PHONE: (305) 558-4124  
FAX: (305) 826-0619  
EB#0004432

SEAL  
EDUARDO L. CARCACHÉ  
CIVIL ENGINEER-PE 31914  
ANA A. GONZALEZ VALDEZ  
ARCHITECT-AR 97769

NO.	DATE	DESCRIPTION
△	07-16-18	(NEW SHIT.)
△		
△		
△		
△		
△		
△		
△		

CONTRACT DATE: \_\_\_\_\_

BUILDING TYPE: EXP. LT. MED-40

PLAN VERSION: x

SITE NUMBER: 309797

STORE NUMBER: 420630

**TACO BELL**

20711 SO. DIXIE HWY  
CUTLER BAY, FL



Explorer Lite  
**GREASE TRAP DETAILS**

C-3.2

PLANT DATE: 07-16-2018