

SITE NUMBER:	####
BASE MODEL:	4058
ASSET TYPE:	COMPANY/FRANCHISE
CLASSIFICATION:	REFRESH
OWNER:	OWNER NAME
BASE VERSION:	2015 OCT 16
UPGRADE CLASSIFICATION:	N/A
PROJECT YEAR:	2015
FURNITURE PACKAGE:	2014
DESIGN BULLETINS:	THRU DB 2015-02

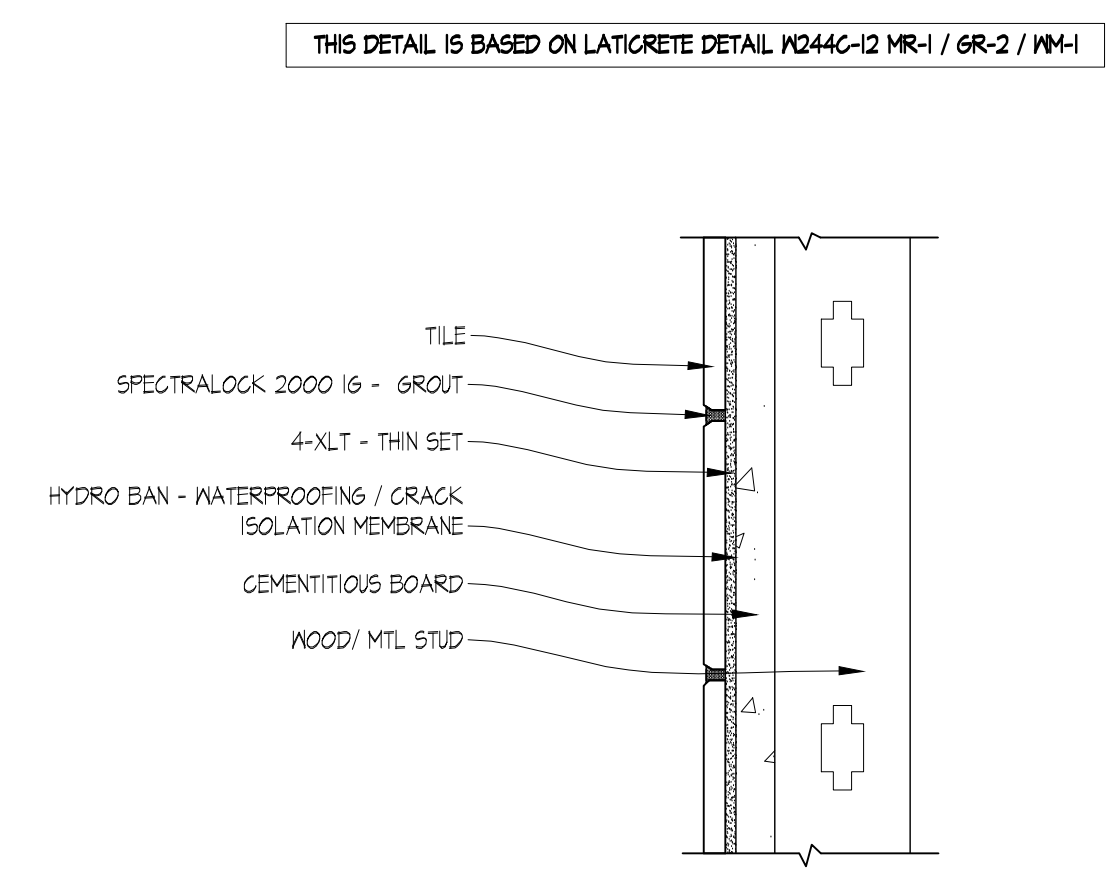

**07 RESTROOM TILE GROUT DETAIL**  
SCALE: 1" = 6" = 1'-0"

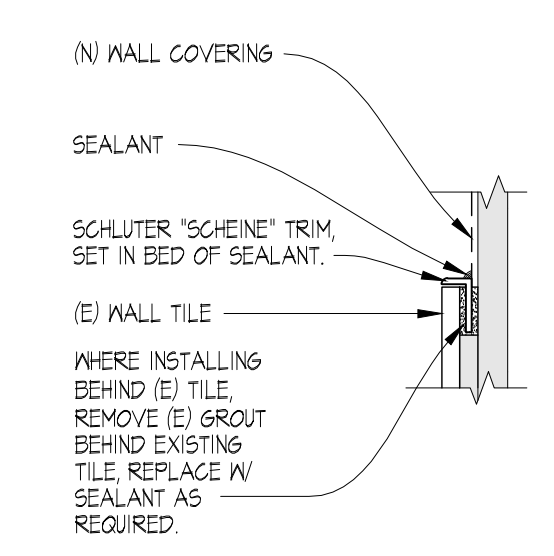

**04 SCHLUTER TRIM DETAIL**  
SCALE: 1/4" = 1'-0"

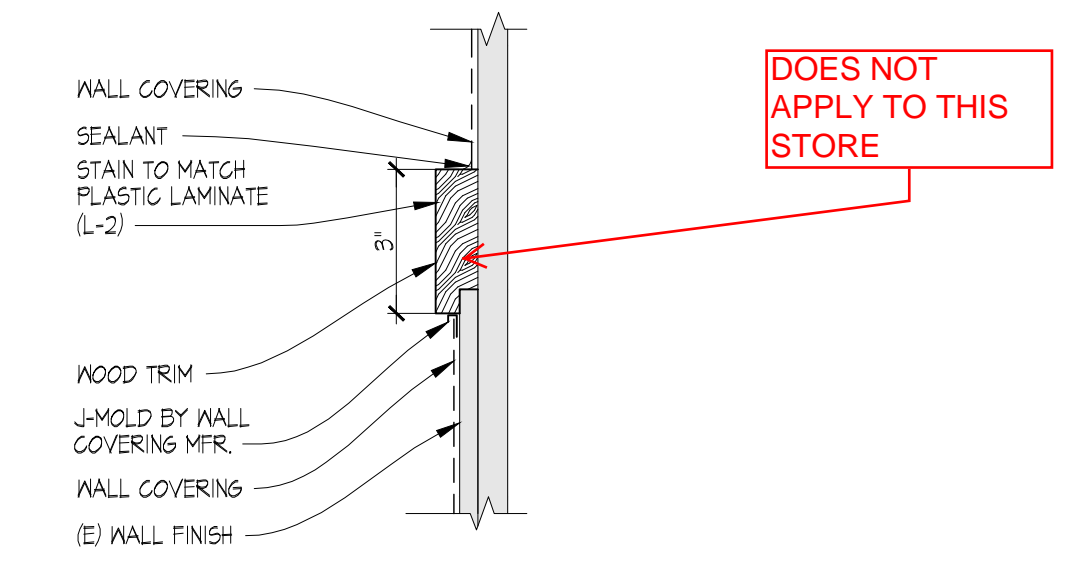

**03 CHAIR RAIL TRIM DETAIL**  
SCALE: 3" = 1'-0"

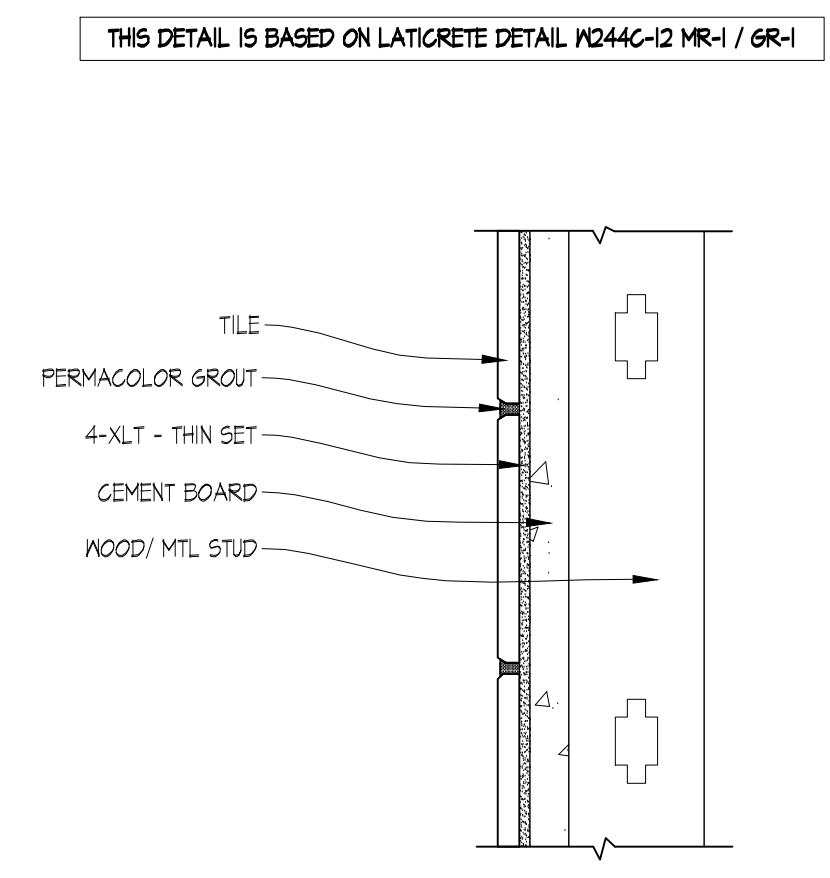

**06 DINING AREA TILE DETAIL**  
SCALE: 1" = 6" = 1'-0"

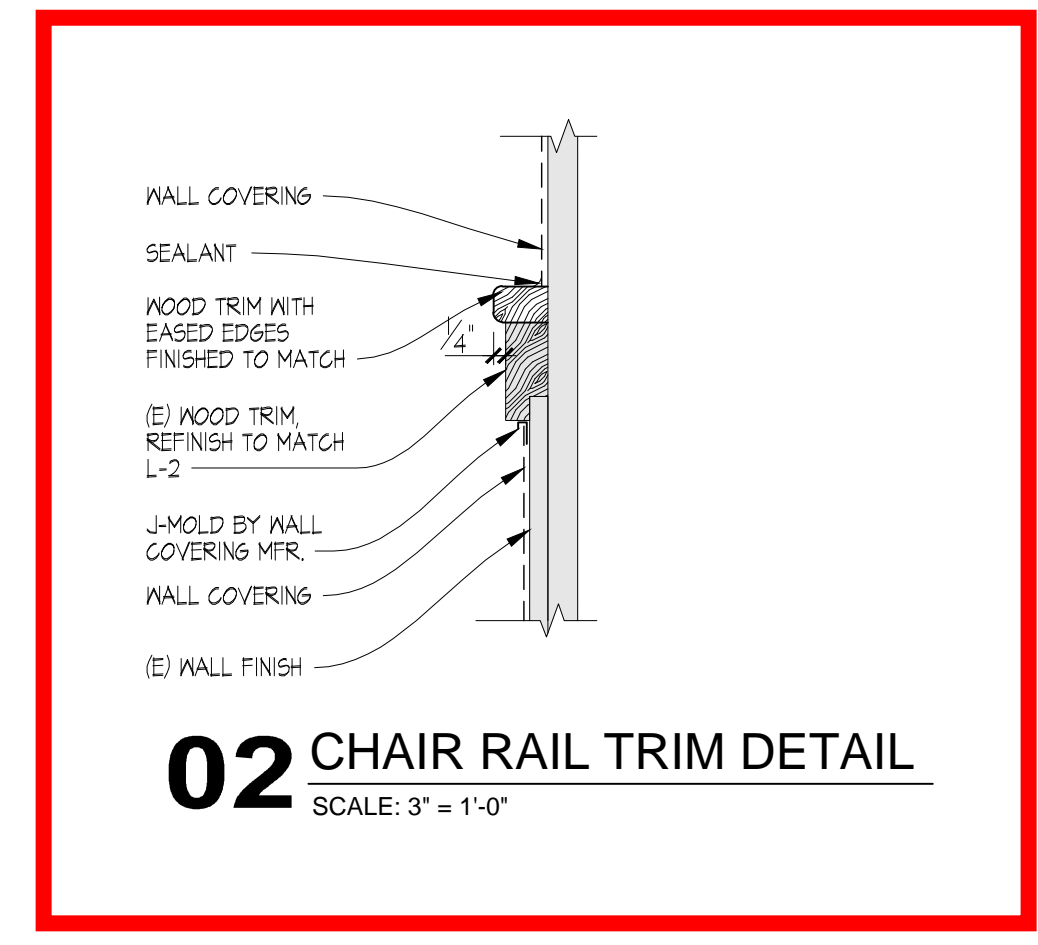

**02 CHAIR RAIL TRIM DETAIL**  
SCALE: 3" = 1'-0"

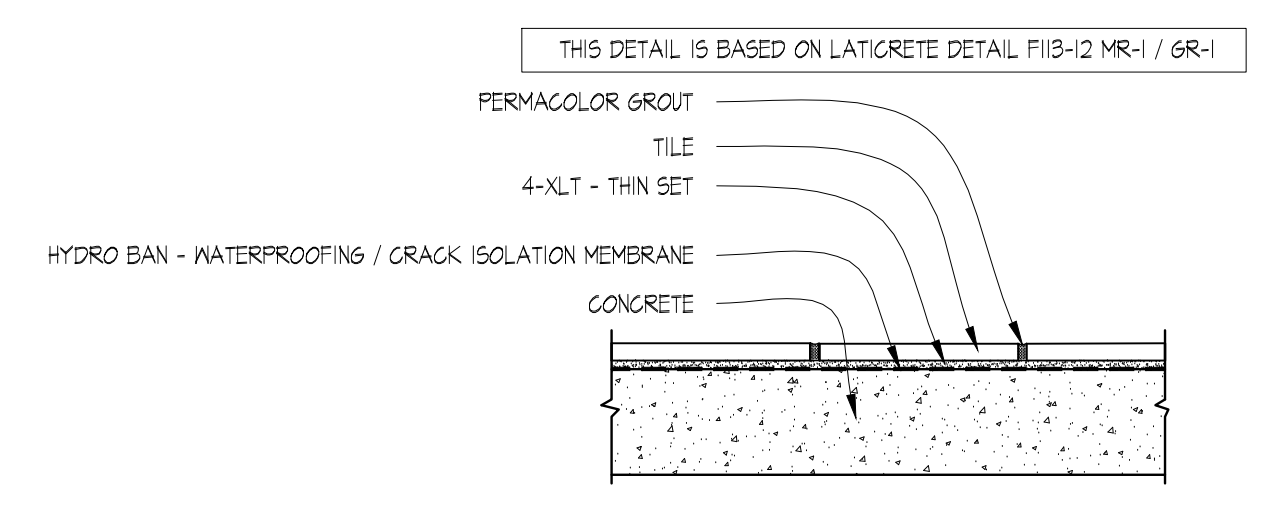

**08 DINING AREA TILE GROUT DETAIL**  
SCALE: 1 1/2" = 1'-0"

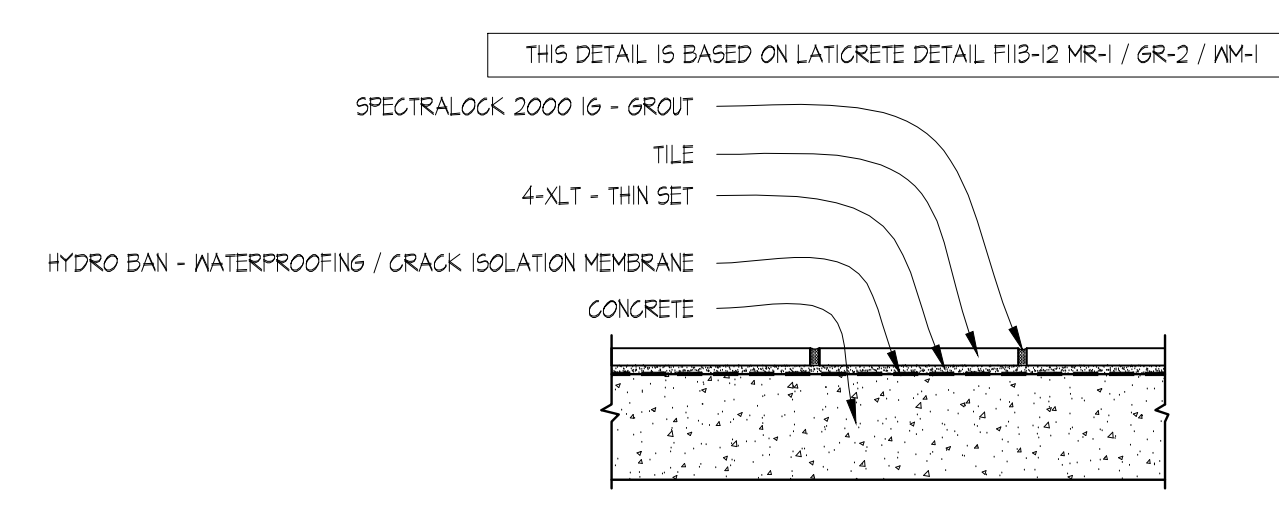

**09 RESTROOM TILE GROUT DETAIL**  
SCALE: 1 1/2" = 1'-0"

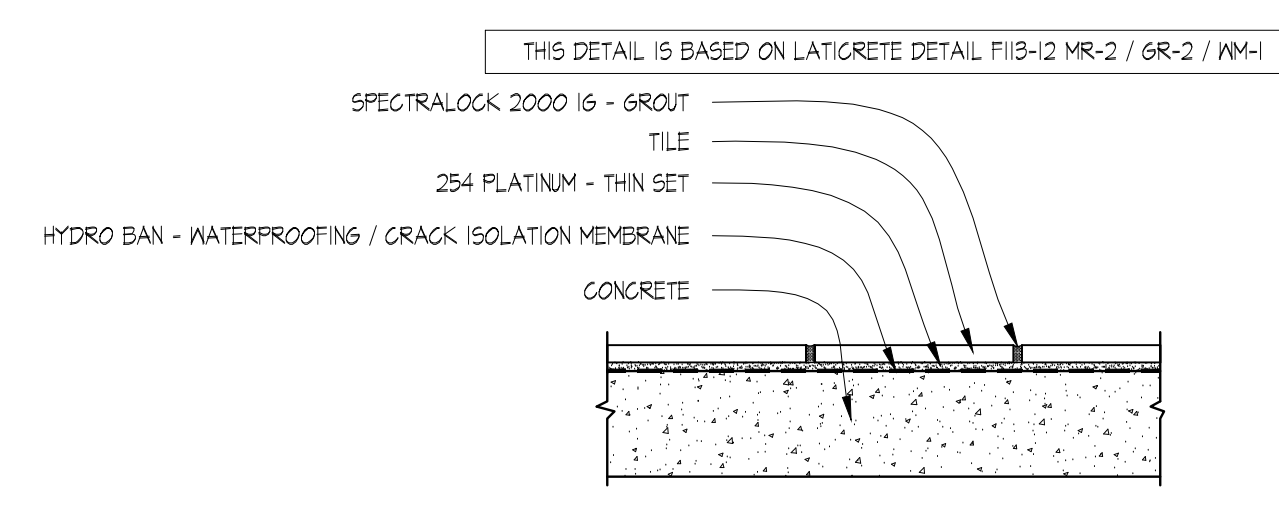

**08 KITCHEN TILE GROUT DETAIL**  
SCALE: 1 1/2" = 1'-0"

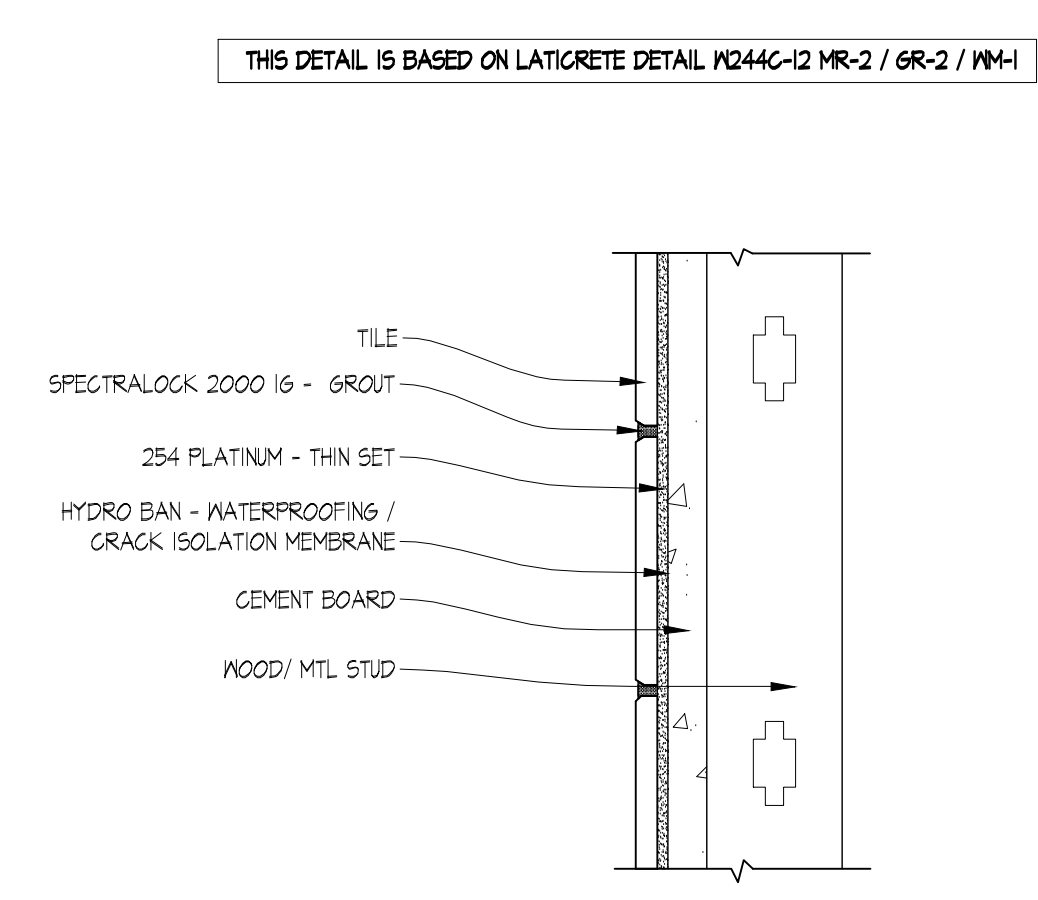

**05 KITCHEN TILE GROUT DETAIL**  
SCALE: 1" = 6" = 1'-0"

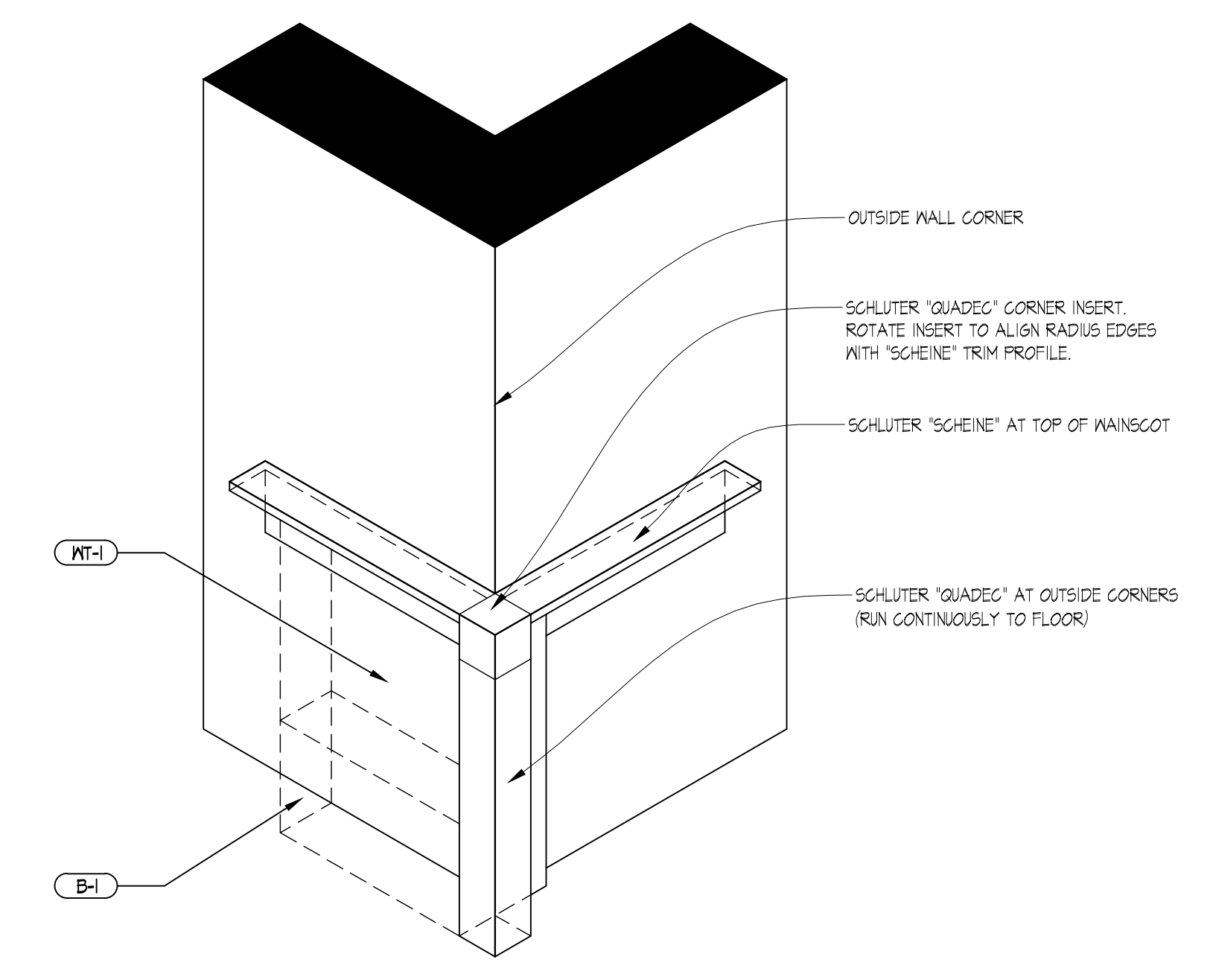

**01 OUTSIDE CORNER AXON**  
SCALE: " = N.T.S.

**Wendy's**  
STREET NUMBER  
CITY, STATE, ZIP

REV.	DATE	DESCRIPTION
-	-	-
-	-	-
-	-	-
-	-	-

ISSUE DATE: 11/11/2015  
PROJECT NUMBER: T.B.D.  
DRAWN BY: XXX  
CHECKED BY: XXX

DESIGN  
GUIDELINE ONLY -  
NOT FOR  
CONSTRUCTION

SHEET NAME  
**FINISH DETAILS**

SHEET NUMBER  
**A5.1**

11/11/2015 10:58 AM P:\PROJECTS\2015\11-11-2015\11-11-2015-001.dwg - 11-11-2015-001.dwg