

Official

# HONDA

## SHOP MANUAL

### CBX

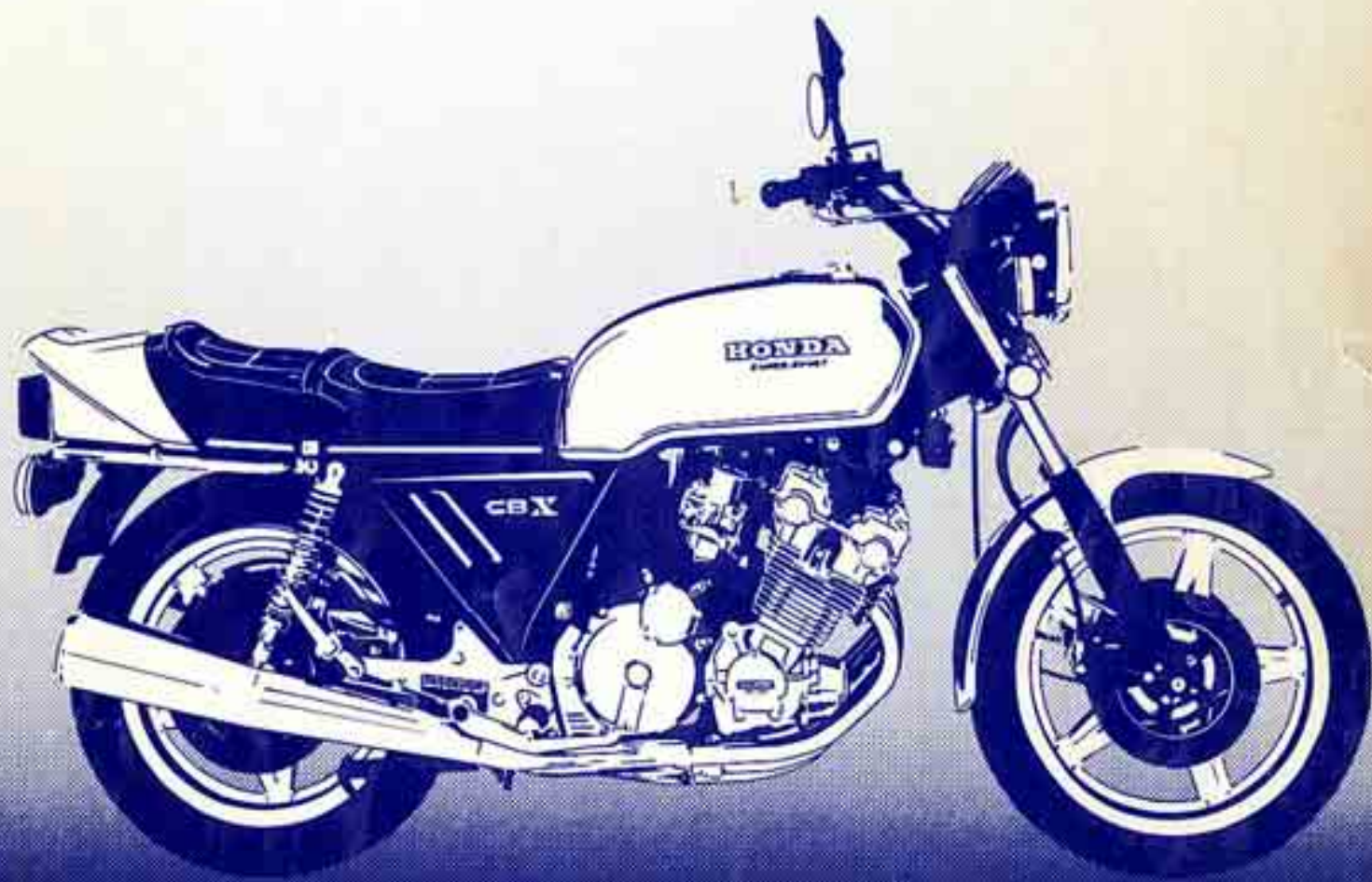

'79 ~ '80

## IMPORTANT SAFETY NOTICE

**WARNING**

*Indicates a possibility of personal injury or loss of life if instructions are not followed.*

**CAUTION**

*Indicates a possibility of equipment damage if instructions are not followed.*

Detailed descriptions of standard workshop procedures, safety principles and service operations are not included. It is important to note that this manual contains some warnings and cautions against some specific service methods which could cause **PERSONAL INJURY** to service personnel or could damage a vehicle or render it unsafe. Please understand that those warnings could not cover all conceivable ways in which service, whether or not recommended by Honda might be done or of the possible hazardous consequences of each conceivable way, nor could Honda investigate all such ways. Anyone using service procedures or tools, whether or not recommended by Honda *must satisfy himself thoroughly* that neither personal safety nor vehicle safety will be jeopardized by the service method or tools selected.





## HOW TO USE THIS MANUAL

Follow the Maintenance Schedule recommendations for each model year to ensure that the vehicle is in peak operating condition and the emission levels are within the US Environmental Protection Agency standards. Performing the first scheduled maintenance is very important. It compensates for the initial wear that occurs during the break-in period.

Sections 1 through 3 apply to the whole motorcycle, while sections 4 through 19 describe parts of the motorcycle, grouped according to location.

Find the section you want on this page, then turn to the table of contents on page 1 of that section.

Most sections start with an assembly or system illustration, service information and troubleshooting for the section. The subsequent pages give detailed procedures.

If you are not familiar with this motorcycle, read the TECHNICAL FEATURES in section 20.

If you don't know the source of the trouble, go to section 21, TROUBLESHOOTING.

Refer to section 22 for 1980 service information.

ALL INFORMATION, ILLUSTRATIONS, DIRECTIONS AND SPECIFICATIONS INCLUDED IN THIS PUBLICATION ARE BASED ON THE LATEST PRODUCT INFORMATION AVAILABLE AT THE TIME OF APPROVAL FOR PRINTING. HONDA MOTOR CO., LTD. RESERVES THE RIGHT TO MAKE CHANGES AT ANY TIME WITHOUT NOTICE AND WITHOUT INCURRING ANY OBLIGATION WHATEVER.

NO PART OF THIS PUBLICATION MAY BE REPRODUCED WITHOUT WRITTEN PERMISSION.

HONDA MOTOR CO., LTD.  
SERVICE PUBLICATIONS OFFICE

## CONTENTS

	GENERAL INFORMATION	1
	LUBRICATION	2
	INSPECTION AND ADJUSTMENT	3
ENGINE	FUEL SYSTEM	4
	ENGINE REMOVAL/INSTALLATION	5
	CYLINDER HEAD/VALVE	6
	CYLINDER/PISTON	7
	CLUTCH (Includes removal of pulser generator)	8
	GEAR SHIFT LINKAGE	9
	CRANKCASE	10
	TRANSMISSION/OIL PUMP	11
	CRANKSHAFT/PRIMARY SHAFT	12
	CHASSIS	FRONT WHEEL/SUSPENSION
REAR WHEEL/SUSPENSION		14
HYDRAULIC BRAKE		15
ELECTRICAL	BATTERY/CHARGING SYSTEM	16
	IGNITION SYSTEM	17
	ELECTRIC STARTER	18
	SWITCHES	19
	TECHNICAL FEATURES	20
	TROUBLESHOOTING	21
	'80 CBX ADDENDUM	22



## MODEL IDENTIFICATION



The frame serial number is stamped on the right side of the steering head.



The vehicle identification number (VIN) is on the left side of the steering head.

**ENGINE SERIAL NUMBER**  
Prior to Eng. No. CB1E-2017146

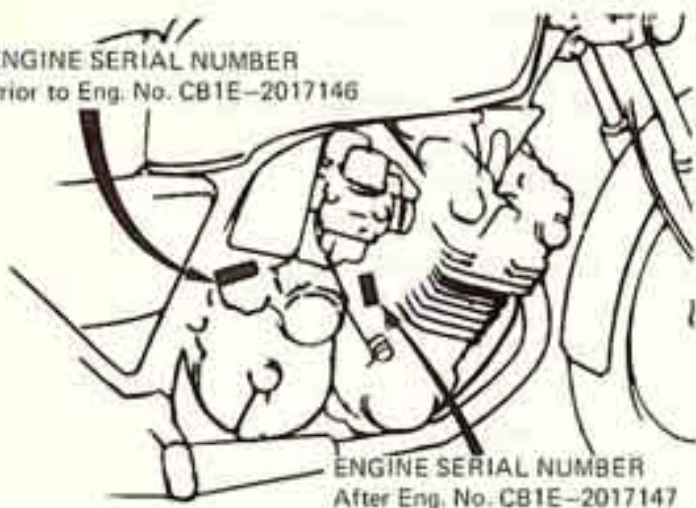

**ENGINE SERIAL NUMBER**  
After Eng. No. CB1E-2017147

The engine serial number is stamped on the top of the crankcase.

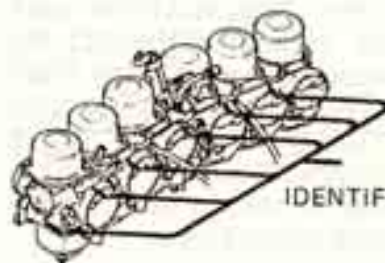

**IDENTIFICATION NUMBER**

The carburetor identification number is on the left of the carburetor body.

8422-08





GENERAL SAFETY	1-1	WIRING DIAGRAMS	1-7
SERVICE RULES	1-1	CABLE & HARNESS ROUTING	1-8
SPECIFICATIONS	1-2	MAINTENANCE SCHEDULE	1-9
TORQUE VALUES	1-4	EMISSION CONTROL SYSTEM	1-10
SPECIAL TOOLS	1-5		

## GENERAL SAFETY

### **WARNING**

*If the engine must be running to do some work, make sure the area is well-ventilated. Never run the engine in a closed area. The exhaust contains poisonous carbon monoxide gas.*

### **WARNING**

*Gasoline is extremely flammable and is explosive under certain conditions. Do not smoke or allow flames or sparks in your working area.*

### **WARNING**

- *The battery electrolyte contains sulfuric acid. Protect your eyes, skin and clothing. In case of contact, flush thoroughly with water and call a doctor if your eyes were exposed.*
- *The battery generates hydrogen gas which can be highly explosive. Do not smoke or allow flames or sparks near the battery, especially while charging it.*

## SERVICE RULES

1. Use genuine HONDA or HONDA-recommended parts and lubricants or their equivalent. Parts that do not meet HONDA's design specifications may damage the motorcycle.
2. Use the special tools designed for this product.
3. Install new gaskets, O-rings, cotter pins, lock plates, etc. when reassembling.
4. When torquing bolts or nuts, begin with larger-diameter or inner bolt first, and tighten to the specified torque diagonally, unless a particular sequence is specified.
5. Clean parts in cleaning solvent upon disassembly. Lubricate any sliding surfaces before reassembly.
6. When installing a new oil seal, make sure that the sealing lip is lubricated with grease. If an oil seal and related parts have been washed, apply proper grease to the lip of the oil seal.
7. After reassembly, check all parts for proper installation and operation.
8. Use only metric tools when servicing this motorcycle. Metric bolts, nuts, and screws are not interchangeable with English fasteners. The use of incorrect tools and fasteners may damage the motorcycle.

**SPECIFICATIONS**

ITEM		
DIMENSIONS	Overall length	2,220 mm (87.4 in)
	Overall width	885 mm (34.8 in)
	Overall height	1,175 mm (46.3 in)
	Wheelbase	1,495 mm (58.9 in)
	Seat height	810 mm (31.9 in)
	Foot peg height	330 mm (13.0 in)
	Ground clearance	150 mm (5.9 in)
	Dry weight	249 kg (548.9 lb)
FRAME	Type	Back-bone Style Diamond-configuration Structure
	Front suspension, travel	Telescopic fork 160 mm (6.3 in)
	Rear suspension, travel	Swing arm 100 mm (3.9 in)
	Front tire size	3.50H19 (4PR)
	Rear tire size	4.25H18 (4PR)
Cold tire pressures	Up to 90 kg (200 lbs) load	Front 2.0 kg/cm <sup>2</sup> (28 psi) Rear 2.8 kg/cm <sup>2</sup> (40 psi)
	Up to vehicle capacity load	Front 2.0 kg/cm <sup>2</sup> (28 psi) Rear 2.8 kg/cm <sup>2</sup> (40 psi)
	F. brake, lining swept area	Double disc brake
	R. brake lining, swept area	Single disc brake
	Fuel capacity	20.0 liters (5.28 US gal)
	Fuel reserve capacity	5.0 liters (1.32 US gal)
	Caster angle	62°30'
	Trail	120 mm (4.7 in)
	Front fork oil capacity	177-182 cc (6.0-6.2 ozs) 157-162 cc (5.3-5.5 ozs) at draining
ENGINE	Type	Air cooled 4-stroke
	Cylinder arrangement	Vertical parallel six
	Bore and stroke	64.5 x 53.4 mm (2.54 x 2.10 in)
	Displacement	1047 cc (63.89 cu in)
	Compression ratio	9.3 : 1
	Valve train	Chain driven D.O.H.C. 4 valve
	Maximum horsepower	103.0 BHP/9,000 rpm
	Maximum torque	8.5 kg-m (61.5 ft-lb)/8,000 rpm
	Oil capacity	5.5 liters (5.8 US qt)
	Lubrication system	Wet sump dual pump system with oil cooler
	Air filtration	Oiled polyurethane form
	Cylinder compression	12.0 ± 1.0 kg/cm <sup>2</sup> (170 ± 14 psi)
	Intake valve	Opens 5° (BTDC) at 1 mm lift, 58° (BTDC) at 0 lift Closes 40° (ABDC) at 1 mm lift, 115° (ABDC) at 0 lift
	Exhaust valve	Opens 40° (BBDC) at 1 mm lift, 94° (BBDC) at 0 lift Closes 5° (ATDC) at 1 mm lift, 71° (ATDC) at 0 lift
	Valve clearance	IN: } 0.08 mm (0.003 in) +0.05 mm (+0.002 in) EX: } -0.02 mm (-0.001 in)
Engine weight	106 kg (234 lb)	
Idle speed	900 ± 100 rpm	
CARBURETION	Carburetor type	VB type, 28 mm (1.1 in) venturi bore
	Identification number	VB60A
	Pilot screw	Refer to 4-26.
	Float level	15.5 mm (0.61 in)





ITEM																				
DRIVE TRAIN	Clutch Transmission Primary reduction Gear ratio I Gear ratio II Gear ratio III Gear ratio IV Gear ratio V Final reduction Gear shift pattern	Wet, multi-plate 5-speed constant-mesh 2.269 2.438 1.750 1.391 1.200 1.037 2.333 (15/35) Left foot operated return system																		
ELECTRICAL	Ignition Ignition timing "F" mark Full advance Starting system Generator Battery capacity Spark plug ( ): Canada Model  Spark plug gap	Transistorized 10° BTDC at 900 ± 100 rpm idle 41° BTDC at 8,000 rpm Starting motor only Three phase A.C. generator 0.35 kw/5,000 rpm 12V - 18AH <table border="1" data-bbox="933 850 1526 1081"> <thead> <tr> <th colspan="2">For cold climate below 5°C, 41°F</th> <th colspan="2">Standard</th> <th colspan="2">For extended high speed operation</th> </tr> <tr> <th>NO</th> <th>NGK</th> <th>NO</th> <th>NGK</th> <th>NO</th> <th>NGK</th> </tr> </thead> <tbody> <tr> <td>X22ES-U</td> <td>D7EA</td> <td>X24ES-U (X24ESR -U)</td> <td>D8EA (D8ES -L)</td> <td>X27ES-U</td> <td>D9EA</td> </tr> </tbody> </table> 0.6-0.7 mm (0.024-0.028 in)	For cold climate below 5°C, 41°F		Standard		For extended high speed operation		NO	NGK	NO	NGK	NO	NGK	X22ES-U	D7EA	X24ES-U (X24ESR -U)	D8EA (D8ES -L)	X27ES-U	D9EA
For cold climate below 5°C, 41°F		Standard		For extended high speed operation																
NO	NGK	NO	NGK	NO	NGK															
X22ES-U	D7EA	X24ES-U (X24ESR -U)	D8EA (D8ES -L)	X27ES-U	D9EA															
LIGHTS	Headlight (low/high beam) Tail/stoplight Turn signal light (front/rear) Speedometer light Tachometer light Neutral indicator Turn signal indicator High beam indicator Running light	55/60W H4 BULB (Phillips 12342/99, or equivalent) 3/32 cp SAE NO. 1157 32/32 cp SAE NO. F. 1034, R. 1073 2 cp SAE NO. 57 2 cp SAE NO. 57 2 cp SAE NO. 57 2 cp SAE NO. 57 2 cp SAE NO. 57 2 cp SAE NO. 57 3 cp SAE NO. 1073																		



## TORQUE VALUES

### • ENGINE

Item	Q'ty	Thread Dia (mm)	Torque kg-m (ft-lb)	Remarks	
Cylinder head cover	8	6	0.8-1.2 ( 6- 9)	Apply molybdenum disulfide base grease to threads and underside of nuts	
Cam holder	32	6	1.2-1.4 ( 9-10)		
Cylinder head	8	10	3.2-3.4 (23-25)		
Cylinder head	10	8	1.9-2.1 (14-15)		
Cam sprocket	4	7	1.4-1.6 (10-12)		
Spark plug	6		1.2-1.6 ( 9-12)		
Crankcase		8	2.3-2.7 (17-20)		Apply molybdenum disulfide base grease to threads and underside of bolts
A.C. generator	1	14	3.6-4.4 (26-32)		
Primary shaft drive gear	1	22	4.0-5.0 (29-36)		See page 12-18
Primary shaft driven sprocket	1	38			
Mainshaft	1	25	4.5-5.5 (33-40)	Apply THREE-BOND	
Drive sprocket	1	10	3.3-3.7 (24-27)		
Connecting rod nut	12	8	2.8-3.2 (20-23)		
Oil filter center bolt	1	20	2.7-3.3 (20-24)		
Oil pressure switch	1		1.5-2.0 (11-15)		
Neutral switch	1	10	1.1-1.5 ( 8-11)		
Oil drain bolt	1	12	2.8-3.2 (20-23)		
Oil pipe	1	8	1.8-2.2 (13-16)		
Oil pipe	1	10	2.0-2.4 (14-17)		

### • CHASSIS

Item	Q'ty	Thread Dia (mm)	Torque kg-m (ft-lb)	Remarks	
Steering stem nut	1	24	8.0-12.0 (58-87)	UBS	
Steering handlebar	2	8	2.8-3.2 (20-23)		
Front fork top bridge	2	7	0.9-1.3 ( 7- 9)		
Front fork bolt	2	31	2.0-3.0 (14-22)		
Front axle nut	1	12	5.5-6.5 (40-47)		
Front/rear brake disc	10	8	2.7-3.3 (20-24)		
Brake hose bolt	5	10	2.5-3.5 (18-25)		
Rear axle	1	18	8.0-10.0 (58-72)		
Final driven sprocket	5	12	8.0-10.0 (58-72)		UBS
Swing arm pivot nut	1	14	6.0-7.0 (43-51)		
Seat strap	2	6	0.8-0.95 ( 6- 7)		
Engine hanger nut	3	14	9.0-10.0 (65-72)		
Air cleaner inlet duct	2	5	0.3-0.6 ( 2- 4)		
Head top thread	1	26	0.8-1.2 ( 6- 9)		

Torque specifications listed above are for the most important tightening points. If a torque specification is not listed, follow the standards given below.

### STANDARD TORQUE VALUES

Type	Torque kg-m (ft-lb)	Type	Torque kg-m (ft-lb)
5 mm bolt, nut	0.45-0.6 (3.3-4.3)	5 mm screw	0.35-0.5 (2.5-3.6)
6 mm bolt, nut	0.8-1.2 (6-9)	6 mm screw	0.7-1.1 (5-8)
8 mm bolt, nut	1.8-2.5 (13-18)	6 mm flange bolt, nut	1.0-1.4 (7-10)
10 mm bolt, nut	3.0-4.0 (22-29)	8 mm flange bolt, nut	2.4-3.0 (17-22)
12 mm bolt, nut	5.0-6.0 (36-43)	10 mm flange bolt, nut	3.0-4.0 (22-29)





**SPECIAL TOOLS/COMMON TOOLS**

- SPECIAL TOOLS (Newly provided)  
CB X SPECIAL TOOL SET No. 07900-4220101 (Includes special tool case)

Tool Name	Part No.	Q'ty	Ref. page
Oil pressure gauge attachment	07510-4220100	1	2-3
Carburetor throttle wrench	07908-4220100	1	3-8, 4-12
Carburetor pilot screw wrench	07908-4220201	1	4-26
Lock nut wrench	07916-4220000	1	8-4, 8-11
Primary gear holder	07924-4250000	1	8-7, 8-8
Piston ring compressor	07954-4220000	4	7-8
Valve lifter holder	07964-4220001	2	3-11
Degree wheel	07974-4220001	1	3-6
Valve lifter hole protector	07999-4220000	1	6-12, 6-18
Pin spanner 55 mm	07902-4220000	1	12-3, 12-18

- SPECIAL TOOLS (Other models)

Tool Name	Part No.	Q'ty	Ref. page
Vacuum gauge set	07504-3000100 (H/C No. 20176)	1	3-7
Oil pressure gauge	07506-3000000	1	2-3
Snap ring pliers	07914-3230001	1	15-8, 15-15
Steering stem socket	07916-3710100	1	13-27
6 mm hex. wrench	07917-3230000	1	13-20, 13-23
Primary shaft holder	07924-6340300	1	12-18
Race bearing remover	07946-3710500	1	13-26
Steering stem driver	07946-3710600	1	13-26
Bearing driver attachment	07946-3710700	1	13-27
Piston base	07958-2500001	4	7-8
Valve guide reamer (5.5 mm)	07984-2000000	1	6-14, 6-16

**• COMMON TOOL**

Tool Name	Part No.	Qty	Appropriation List (Common tool → Special tool)	Ref. Page
Float level gauge	07401-0010000	1		4-9
Pin spanner	07702-0010000	1		14-4, 14-7
Retainer wrench (A)	07710-0010100	1		14-4, 14-7
Retainer wrench (C)	07710-0010300	1	Bearing retainer wrench 07910-3930000	13-15, 13-17
Retainer wrench body	07710-0010401			13-15, 13-17, 14-4, 14-7
Lock nut wrench socket (26 x 30 mm)	07716-0020202	1		13-25, 13-28
Extension bar	07716-0020500	1		13-25, 13-28
Universal holder	07725-0010101	1	Flywheel holder 07923-0400000	8-3
Valve guide remover (5.5 mm)	07742-0010100	1	Valve guide driver 07942-3290100	6-15, 6-16
Bearing driver outer (32 x 35)	07746-0010100	1	Bearing driver 07946-4150200	16-7
Bearing driver outer (37 x 40)	07746-0010200	1		12-15, 16-7
Bearing driver outer (42 x 47)	07746-0010300	1	Bearing driver 07946-9350000	13-17
Bearing driver outer (52 x 55)	07746-0010400	1	Bearing driver 07946-3290000	12-16, 14-6
Bearing driver outer (62 x 68)	07746-0010500	1	Bearing driver 07946-3600000	14-6
Bearing driver handle (C)	07746-0030100	1		11-13, 12-16
Bearing driver inner (25 mm)	07746-0030200	1		12-16
Bearing driver inner (30 mm)	07746-0030300	1		11-13
Bearing driver pilot (15 mm)	07746-0040300	1		13-17
Bearing driver pilot (20 mm)	07746-0040500	1		14-6
Bearing driver pilot (25 mm)	07746-0040600	1		12-15, 12-16, 14-6
Front fork oil seal driver body	07747-0010100	1	Fork seal driver 07947-3290000	13-22
Front fork oil seal attachment (E)	07747-0010600	1		13-22
Bearing driver handle (A)	07749-0010000	1	Driver handle attachment 07949-6110000	12-15, 12-16, 13-17
				14-6, 16-7
Valve spring compressor	07757-0010000	1	Valve spring compressor 07957-3290001	6-12, 6-18
Shock absorber compressor	07959-3290001	1		14-9, 14-10





### MAINTENANCE SCHEDULE

Perform the PRE-RIDE INSPECTION in the Owner's Manual at every maintenance period.

I : INSPECT, CLEAN, ADJUST, LUBRICATE, OR REPLACE IF NECESSARY.

C: CLEAN

R: REPLACE

A: ADJUST

L: LUBRICATE

ITEM	FREQUENCY	WHICHEVER OCCURS FIRST ↓	ODOMETER READING [NOTE (3)]							Refer to
			600 mi. (1,000 km)	3,750 mi. (6,000 km)	7,500 mi. (12,000 km)	11,250 mi. (18,000 km)	15,000 mi. (24,000 km)	18,750 mi. (30,000 km)		
EMISSION RELATED ITEMS	ENGINE OIL	YEAR	R	R	R	R	R	R	Page 2- 2	
	ENGINE OIL FILTER	YEAR	R	R	R	R	R	R	Page 2- 2	
	* ENGINE OIL SCREEN					C			Page 2- 3	
	CRANKCASE BREATHER	NOTE (1)		C	C	C	C	C	Page 3- 3	
	AIR CLEANER	NOTE (2)		C	C	C	C	C	Page 3- 2	
	* FUEL LINES			I	I	I	I	I	Page 3- 3	
	SPARK PLUGS			I	R	I	R	I	Page 3- 4	
	* VALVE CLEARANCE			I	I	I	I	I	Page 3-10	
	* IGNITION TIMING			I	I	I	I	I	Page 3- 5	
	* CAM CHAIN TENSION			A	A	A	A	A	Page 3-14	
	* THROTTLE OPERATION			I	I	I	I	I	Page 3- 6	
	* CARBURETOR IDLE SPEED			I	I	I	I	I	Page 3- 9	
	* CARBURETOR CHOKE				I	I	I	I	Page 3- 9	
	* CARBURETOR SYNCHRONIZE			I	I	I	I	I	Page 3- 7	
NON-EMISSION RELATED ITEMS	DRIVE CHAIN		I, L EVERY 300 mi. (500 km)							Page 3-16
	BATTERY	MONTH	I	I	I	I	I	I	Page 3-17	
	BRAKE FLUID	MONTH I 2 YEARS R	I	I	I	*R	I	I	Page 3-17	
	BRAKE PAD WEAR			I	I	I	I	I	Page 3-18	
	BRAKE SYSTEM			I	I	I	I	I	Page 3-18	
	* BRAKE LIGHT SWITCH			I	I	I	I	I	Page 3-19	
	* HEADLIGHT AIM			I	I	I	I	I	Page 3-19	
	CLUTCH FREE PLAY			I	I	I	I	I	Page 3-20	
	SIDE STAND			I	I	I	I	I	Page 3-21	
	* SUSPENSION			I	I	I	I	I	Page 3-22	
	* NUTS, BOLTS, FASTENERS			I	I	I	I	I	Page 3-23	
** WHEELS			I	I	I	I	I	Page 3-22		
** STEERING HEAD BEARING			I	I	I	I	I	Page 3-23		

\*\* IN THE INTEREST OF SAFETY, WE RECOMMEND THESE ITEMS BE SERVICED ONLY BY AN AUTHORIZED HONDA DEALER.

\* SHOULD BE SERVICED BY AN AUTHORIZED HONDA DEALER, UNLESS THE OWNER HAS PROPER TOOLS AND SERVICE DATA AND IS MECHANICALLY QUALIFIED.

NOTES: (1) MORE FREQUENT SERVICE MAY BE REQUIRED WHEN RIDING IN RAIN, OR AT FULL THROTTLE. (U.S.A. ONLY)

(2) MORE FREQUENT SERVICE MAY BE REQUIRED WHEN RIDING IN DUSTY AREAS.

(3) FOR HIGHER ODOMETER READINGS, REPEAT AT THE FREQUENCY INTERVAL ESTABLISHED HERE.



## EMISSION CONTROL SYSTEM

The CBX is equipped with two Emission Control Systems.

### EXHAUST EMISSION CONTROL SYSTEM

The exhaust emission control system is composed of a factory pre-set carburetor. No adjustment should be made except to the idle speed with the throttle stop screw.

### CRANKCASE EMISSION CONTROL SYSTEM

The engine is equipped with a "Closed System" to prevent crankcase emissions entering the atmosphere. Blow-by gas is returned to the combustion chamber through the air cleaner and carburetor. Liquids are collected in the drain tube.

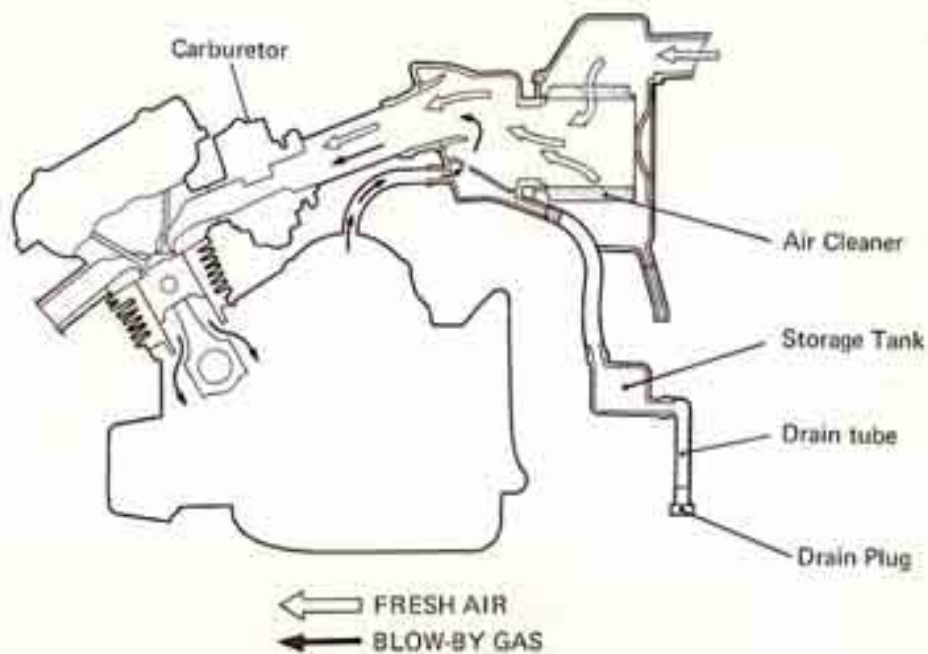

### EMISSION CONTROL INFORMATION LABEL

An Emission Control Information Label is located on the frame as shown. It contains basic tune-up specifications.







LUBRICATION

ENGINE LUBRICATION DIAGRAM

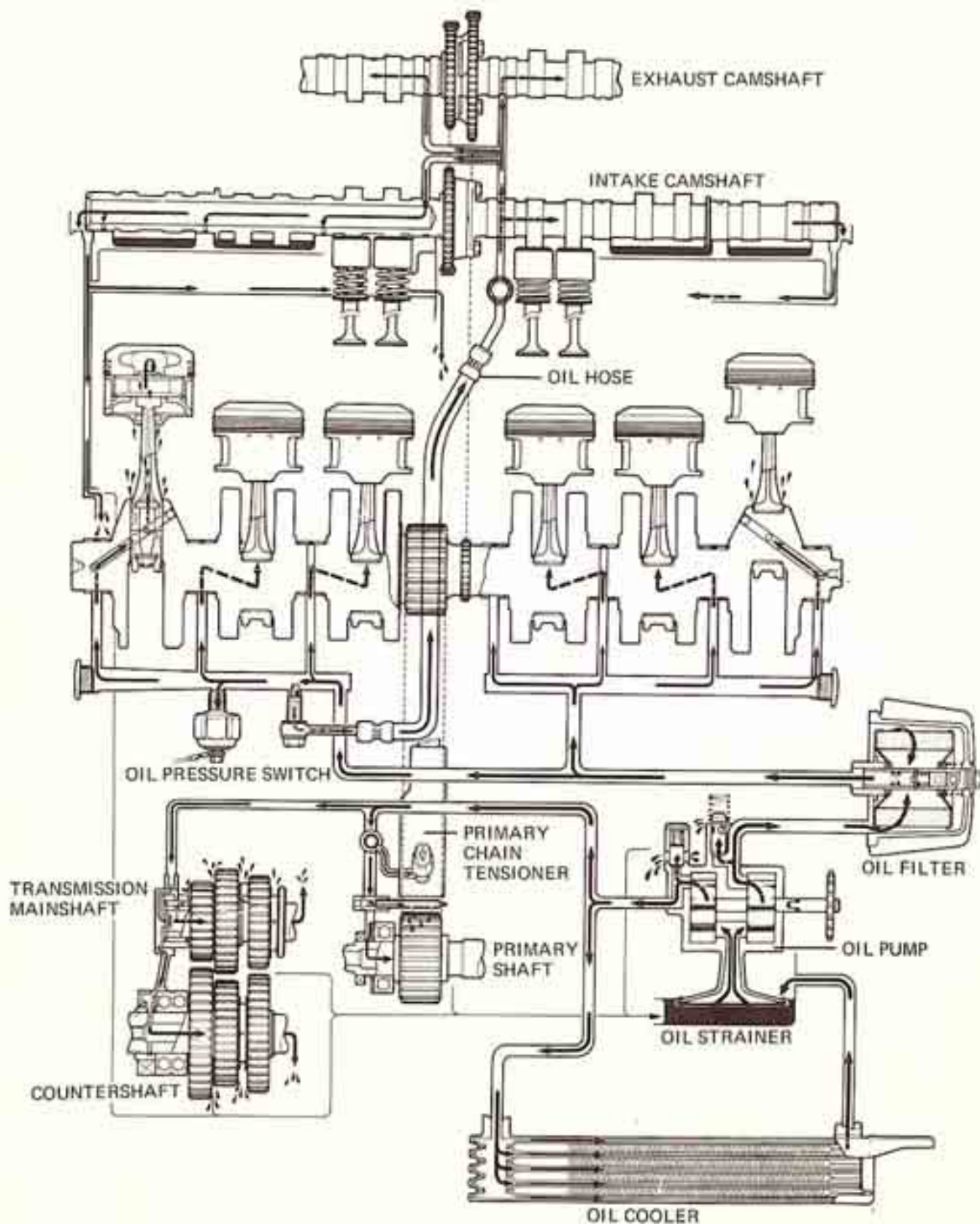





SERVICE INFORMATION	2-1	OIL PRESSURE	2-3
TROUBLESHOOTING	2-1	OIL COOLER INSPECTION	2-3
<u>ENGINE LUBRICATION</u>		OIL HOSE AND BOLT INSPECTION	2-4
ENGINE OIL LEVEL	2-2	<u>CHASSIS LUBRICATION</u>	
ENGINE OIL & FILTER CHANGE	2-2	LUBRICATION POINTS	2-5
OIL STRAINER SCREEN CLEANING	2-3	DRIVE CHAIN	2-5

## SERVICE INFORMATION

### WORKING PRACTICE

Oil pump: See Section 11  
Oil pressure relief valve: See Section 11

### SPECIFICATIONS

Oil capacity	Approximately 4.0 liter (4.2 US qt) at change 5.5 liter (5.8 U.S. qt) at engine assembly		
Recommended oil	HONDA 4-stroke oil or equivalent General, all temperature Alternate Above 15°C (60°F) -10° to 15°C (15° to 60°F) Above -10°C (15°F) Below 0°C (32°F)		API service classification-SE SAE 10W-40 SAE 30 SAE 20 or 20W SAE 20W-50 SAE 10W
Oil pump delivery	Right	36.5 liters/min/4,000 rpm	(38.6 qt/min/4,000 rpm)
	Left	27.0 liters/min/4,000 rpm	(28.5 qt/min/4,000 rpm)
Oil pressure (at oil pressure switch)	4.5-5.0 kg/cm <sup>2</sup> (64-71 psi)/4,000 rpm		80°C (176°F)

### SPECIAL TOOLS

#### Special Tools

Oil Pressure Gauge 07506-3000000  
Oil Pressure Gauge Attachment 07510-4220100

### TORQUE VALUES

Oil drain plug	2.8-3.2 kg-m (20-23 ft-lb)	Pressure switch	1.5-2.0 kg-m (11-15 ft-lb)
Oil filter bolt	2.7-3.3 kg-m (20-24 ft-lb)	Oil bolt (Cylinder head)	1.8-2.2 kg-m (13-16 ft-lb)
Oil pan bolt	0.8-1.2 kg-m (6-9 ft-lb)	Oil bolt (Crankcase)	2.0-2.4 kg-m (14-17 ft-lb)

## TROUBLESHOOTING

#### Oil Level Too Low

1. External oil leaks
2. Worn piston rings
3. Worn valve guide or seal

#### Oil Contamination

1. Oil or filter not changed often enough
2. Head gasket faulty
3. Worn piston rings

#### Low Oil Pressure

1. Oil level low
2. Pressure relief valve stuck open
3. Plugged oil pick-up screen
4. Oil pump worn
5. External oil leaks

#### High Oil Pressure

1. Pressure relief valve stuck closed
2. Plugged oil filter, gallery, or metering orifice
3. Incorrect oil being used

#### No Oil Pressure

1. Oil level low
2. Oil pump drive chain broken
3. Oil pump faulty
4. Internal oil leakage



## ENGINE LUBRICATION

### ENGINE OIL LEVEL

Run the engine and allow to idle for a few minutes.\*

Stop the engine and place the motorcycle on its center stand. Check the oil level with the filler cap/dipstick after a few minutes. Do not screw in the cap when making this check. If the level is below the lower level mark on the dipstick, fill to the upper level mark.

Check the oil pressure warning light. This light should go off when the engine starts. If it does not, check the oil pump operation and/or oil circuit.

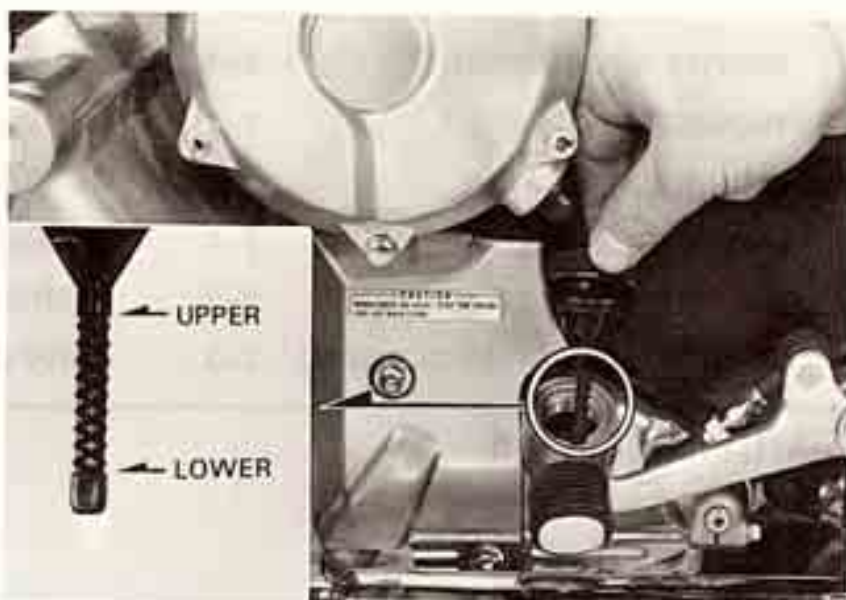

## ENGINE OIL & FILTER CHANGE

### NOTE

Before draining the oil, warm the engine to normal operating temperature.

Stop the engine.

Place the motorcycle on its center stand.

Remove the oil filler cap, drain plug and oil filter bolt and drain the oil.

Replace the oil filter and install the oil filter bolt and drain plug.

### CAUTION

*Do not interchange the oil filter with those for other models as it has a greater rate of oil flow.*

Make sure that the sealing washer on the drain plug and the O-rings on the oil filter bolt and oil filter case are in good condition.

Fill the crankcase with 4.0 lit (4.2 US qt) of the recommended oil.

Reinstall the oil filler cap.

Start the engine and idle it for a few minutes.

Stop the engine.

Add the recommended oil to the upper level.

Make sure that there are no oil leaks.

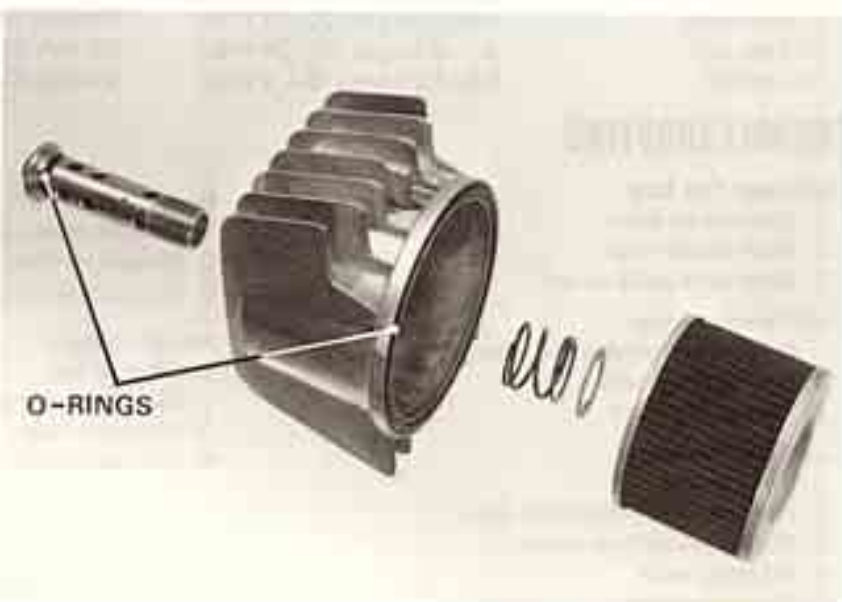





### OIL STRAINER CLEANING

Remove the oil filler cap, drain plug and oil filter bolt.

Remove the oil pan bolts and oil pan.

Remove and clean the oil strainer.

Install the oil strainer and oil pan.

Fill the crankcase with the recommended oil (Page 2-2).



### OIL PRESSURE

Connect the oil pressure gauge.

Check the oil level.

Warm the engine up to normal operating temperature (approximately 80° C = 176° F).

Check the pressure at 4,000 rpm.

**STANDARD:** 4.5-5.0 kg/cm<sup>2</sup> (64-71 psi)  
at 4,000 rpm 80° C (176° F)

#### NOTE

Before installing the pressure switch, apply a liquid sealant to the thread.

Check that the oil pressure warning light goes out. If the oil pressure warning light stays on, stop the engine immediately and determine the cause.

Also, check to be sure by touching the oil cooler that the cooler is warmed up by the oil coming from the auxiliary oil pump.



### OIL COOLER INSPECTION

Check for damage to the oil cooler core.

Clean the core if necessary.







## OIL HOSE AND BOLT INSPECTION

Check for oil leaks at hose connections.  
Check the oil hoses for deterioration.

### NOTE

- Install new sealing washers, if the hose is removed.
- Install the oil bolt with the oil orifice on the crankcase side.

Check that the oil orifice is not clogged.

to CRANKCASE

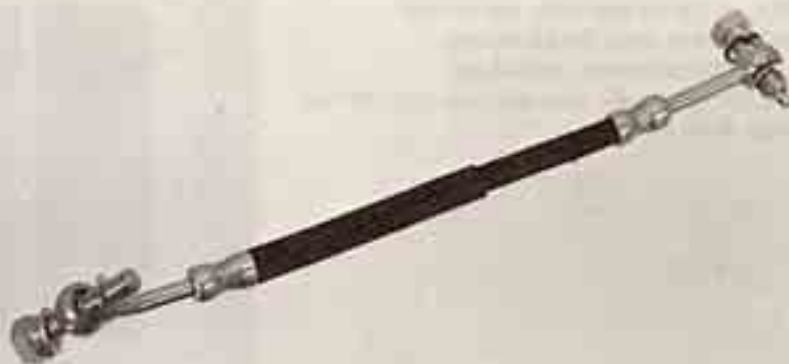

to CYLINDER HEAD





### CHASSIS LUBRICATION LUBRICATION POINTS

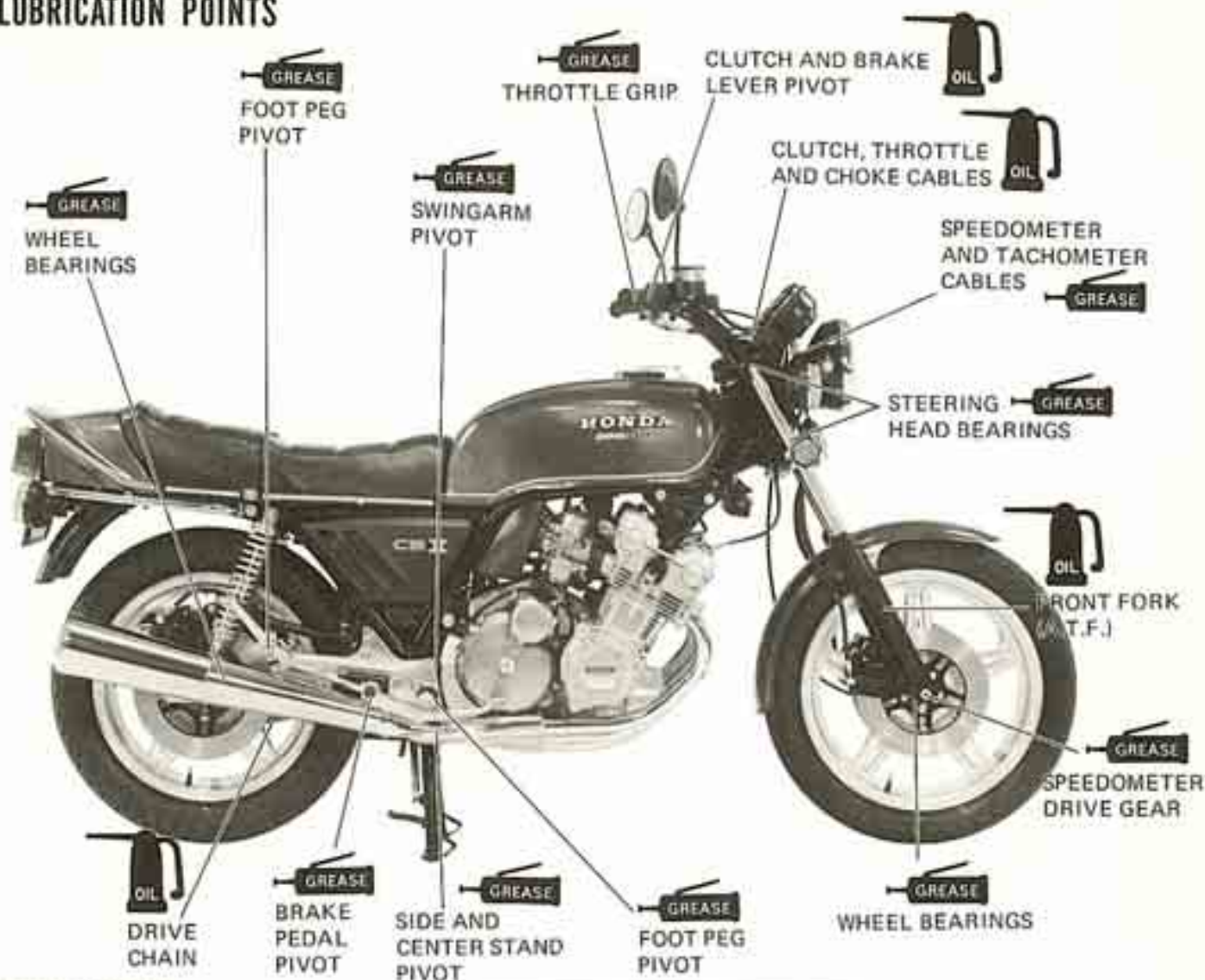

### DRIVE CHAIN

Clean the drive chain with kerosene and wipe dry.

#### CAUTION

*Do not use a steam cleaner, high pressure washers or solvents as these will damage the O-rings.*

Lubricate the drive chain with SAE 80 or 90 gear oil.

#### CAUTION

*Do not use commercial aerosol chain lubricants. They contain solvents which could damage the O-rings.*

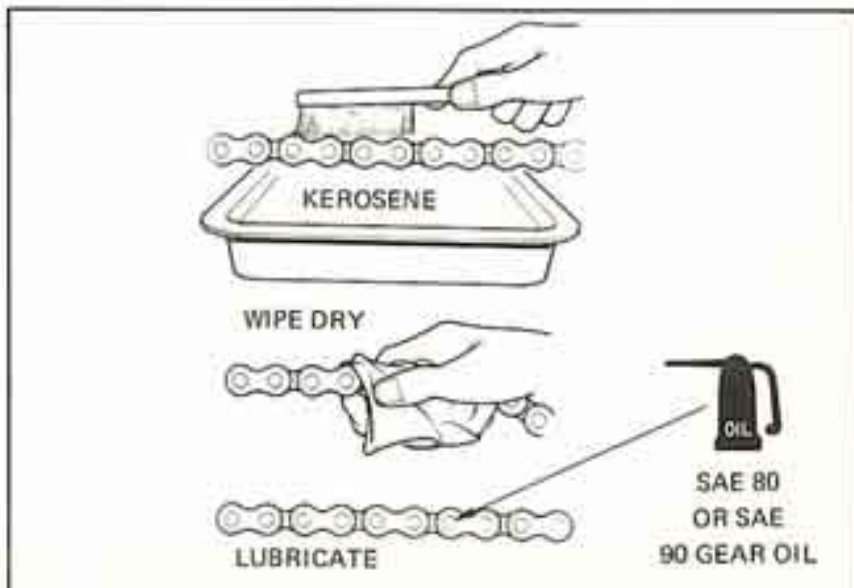



SERVICE INFORMATION	3-1		
<b>&lt;ENGINE&gt;</b>		<b>&lt;CHASSIS&gt;</b>	
AIR CLEANER	3-2	DRIVE CHAIN	3-16
CRANKCASE BREATHER	3-3	BATTERY	3-17
FUEL LINES	3-3	BRAKE FLUID	3-17
SPARK PLUGS	3-4	BRAKE PAD WEAR	3-18
IGNITION TIMING	3-5	BRAKE SYSTEM	3-18
SPARK ADVANCER	3-6	BRAKELIGHT SWITCH	3-19
THROTTLE OPERATION	3-6	HEADLIGHT AIM	3-19
CARBURETOR SYNCHRONIZATION	3-7	CLUTCH FREE PLAY	3-20
CHOKE MECHANISM	3-9	SIDE STAND	3-21
IDLE SPEED	3-9	SUSPENSION	3-22
VALVE CLEARANCE	3-10	WHEELS	3-22
CAM CHAIN	3-14	STEERING HEAD BEARING	3-23
COMPRESSION TEST	3-15	NUTS, BOLTS, FASTNERS	3-23

## SERVICE INFORMATION

### WORKING PRACTICE

Engine oil level check	See page 2-2
Engine oil change	See page 2-2
Oil strainer screen cleaning	See page 2-3

### SPECIAL TOOLS

Special tools	
Valve lifter holder	07964-4220000
Carb. throttle wrench	07908-4220100
Degree wheel	07974-4220000
Vacuum gauge	07404-0020000 or H/C 20176

### SPECIFICATION

#### <ENGINE>

Spark plug gap	0.6-0.7 mm (0.024-0.028 in)
Spark plug type	
U.S.A. model only	

Manu- facturer \ Usage	For cold climate (below 5°C)	Standard	For extended high speed operation
ND	X22ES-U	X24ES-U	X27ES-U
NGK	D7EA	D8EA	D9EA

#### CANADA model only

ND	X24ESR-U
NGK	DR8ES-L

#### Manufacturer

ND:	Nippondenso Co., Ltd.
NGK:	NGK Spark Plug Co., Ltd.

Ignition timing	Initial 10° (BTDC)
Valve clearance: IN. and EX.	0.08 <sup>+0.05</sup> <sub>-0.02</sub> mm (0.003 <sup>+0.0020</sup> <sub>-0.0008</sub> in)
Idle speed	900 ± 100 rpm
Synchronization vacuum	Difference of each cylinder 40 mm Hg (1.6 in Hg)
Compression	12 ± 1 Kg/cm <sup>2</sup> (170 ± 14 psi)

#### <CHASSIS>

Drive chain free play	15-25 mm (5/8 in)
Clutch free play	10-20 mm (3/8-3/4 in)

#### Tire

Cold tire pressures Kg/cm <sup>2</sup> (psi)	Front 2.0 (28) Rear 2.8 (40)
Vehicle capacity/load limit	163 Kg (360 lbs)
Tire size	Front 3.50H19-4PR Rear 4.25H18-4PR
Tire brand Tubeless only	Front GOLD SEAL F11 (DUNLOP) M&G. MOPUS-S703 (BRIDGESTONE) Rear GOLD SEAL K127 (DUNLOP) M&G. MOPUS-G504 (BRIDGESTONE)

### TORQUES

Front axle holder nut	1.8-2.5 kg-m (13-18 ft-lb)
Rear axle nut	8.0-10.0 kg-m (58-72 ft-lb)





## AIR CLEANER MAINTENANCE

Remove the seat.

Remove the two screws and the air cleaner inlet duct.



Remove the air cleaner set spring.



Remove the air cleaner element retainer and element.





Wash the element in non-flammable or high flash point solvent.

Allow to dry.

Soak the element in gear oil (SAE 80-90) and squeeze out the excess.



Install the air cleaner element.  
Install the holder, set spring and air cleaner inlet duct.  
Install the seat.

## CRANKCASE BREATHER

For U.S.A. model

Remove the drain plug from the tube and drain deposits.

Reinstall the drain plug.

### NOTE

Service more frequently when driven in rainy conditions or at wide open throttle, or if the deposit level can be seen in the transparent section of the drain tube.

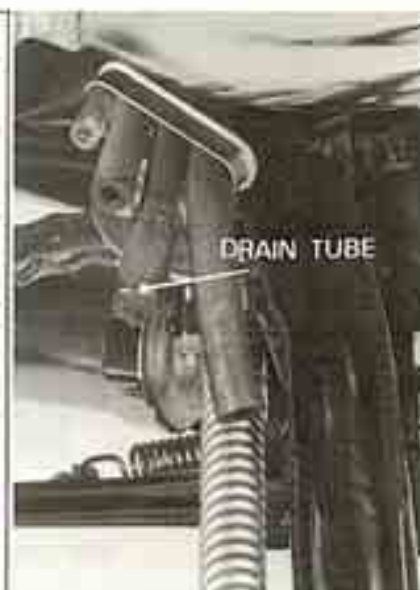
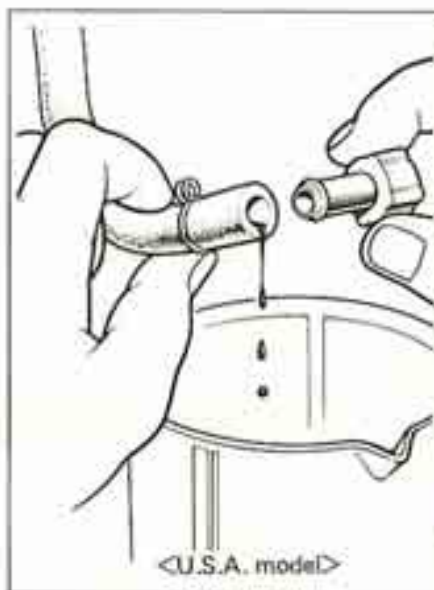

For Canada model

Squeeze to open the lower end of the drain tube.

Remove any oil or water which may have accumulated.

### CAUTION

Check the drain tube for clogging and routing.

## FUEL LINES

Replace any parts which show deterioration, damage or leakage.





## SPARK PLUGS

Disconnect the spark plug caps and remove the spark plugs.

Visually inspect the spark plug electrodes for wear. The center electrode should have square edges and the side electrodes should have a constant thickness. Discard the spark plug if there is apparent wear or if the insulator is cracked or chipped. If the spark plug deposits can be removed by sandblasting, the spark plug can be reused.

Adjust the spark plug gap by bending the side electrode.

**SPARK PLUG GAP: 0.6–0.7 mm**  
(0.024–0.028 in)

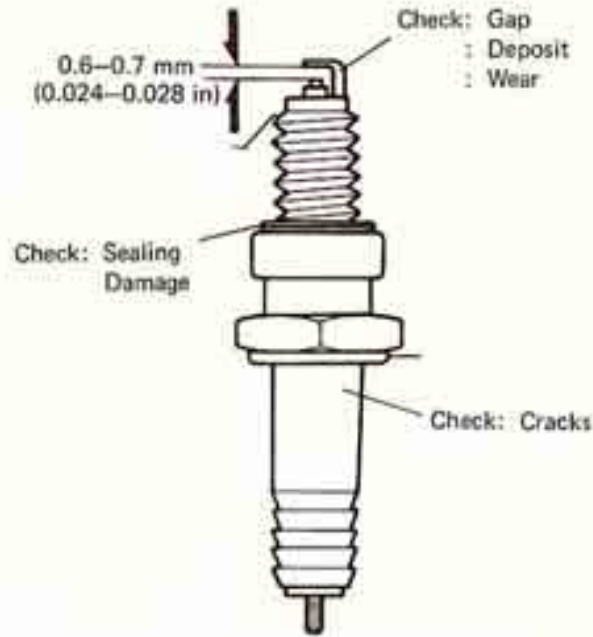

### RECOMMENDED SPARK PLUG

For U. S. A. model only

Usage	For cold climate (below 5° C)	Standard	For extended high speed operation
Manufacturer			
ND	X22ES-U	X24ES-U	X27ES-U
NGK	D7EA	D8EA	D9EA

For CANADA model only

ND: X24ESR-U

NGK: DR8ES-L

Manufacturer: ND: Nippondenso Co., Ltd.

NGK: NGK Spark Plug Co., Ltd.

Reinstall the spark plugs and reconnect the spark plug caps.

#### NOTE

First tighten the spark plug finger tight, then tighten with a spark plug wrench.





### IGNITION TIMING CHECK

#### • DYNAMIC

##### NOTE

Drain oil from engine for this inspection method. Place an oil drain pan under the right crankshaft end.

Remove all spark plug caps and either No. 6 plug spark or No. 1 spark plug. Connect the removed plug with the spark plug cap and ground the plug to the cylinder head.

Remove the right crankshaft cap. Connect a stroboscopic timing light to the grounded high tension cord. Operate the starter motor while aiming the timing light at the right crankshaft end. The "F" mark should align with the front crankcase mating surfaces.

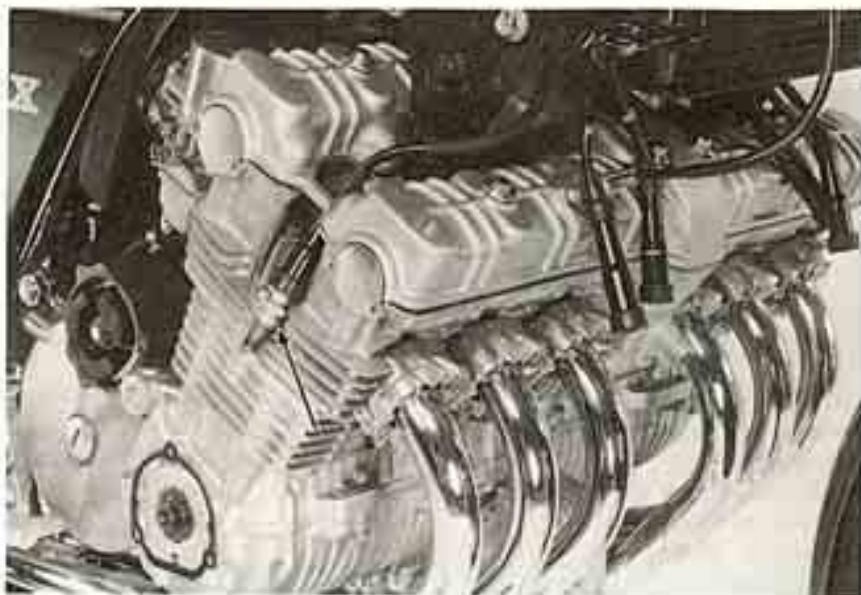

#### ADJUSTMENT

Remove the pulser coil cover. Adjust by loosening the three pulser base plate screws and rotating the plate. Tighten the screws and recheck the timing.

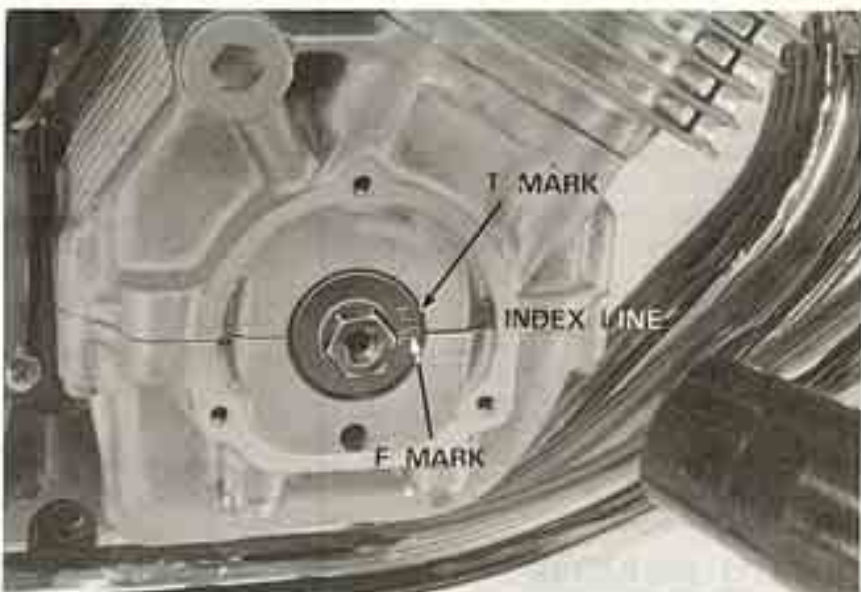

#### ALTERNATIVE METHOD

(Can be done with oil in engine.)

#### • STATIC

Remove right crankshaft cap and pulser coil cover. Rotate crankshaft clockwise and align "F" mark with front crankcase mating surfaces.

##### NOTE

Either No. 6 or No. 1 piston must be near T.D.C. of the compression stroke at this time.

The timing is correct if the narrow projection of "1-6" pulser generator is aligned with the rotor tooth.

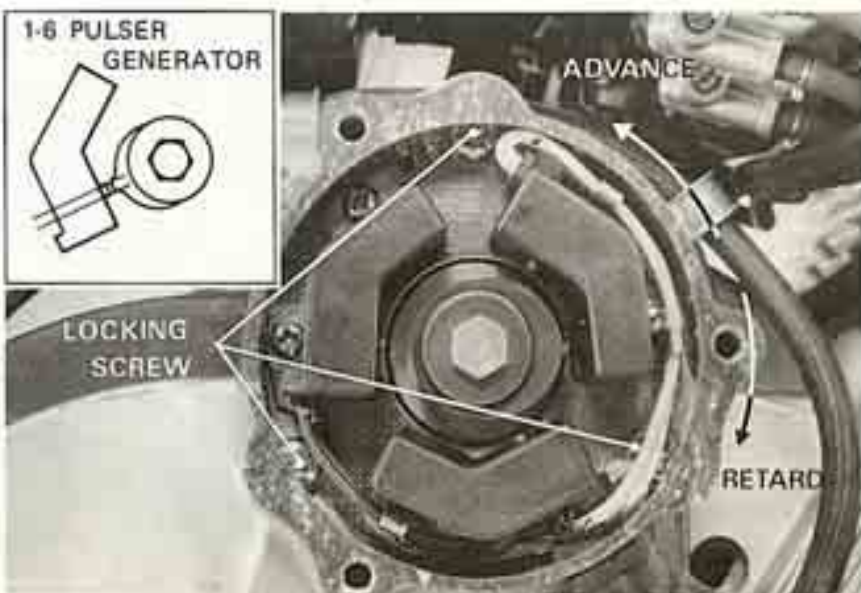



## SPARK ADVANCER

### NOTE

- Check the spark advancer only if engine performance difficulties occur.
- A high quality stroboscopic timing light designed for transistorized ignition systems must be used. It should also be capable of accurate operation at 8,000 rpm.

Remove the pulser cover.

Remove the rotor bolt and install the special degree wheel.

Align initial mark on the degree wheel with the rotor tooth and tighten the bolt.

Connect a timing light to the No.6 high tension wire.

Start the engine.

Check that the initial mark remains aligned with the rotor tooth at idle.

Increase engine speed and check that the 23.5 degree mark aligns with the rotor tooth between 2,200 and 2,600 rpm.

And then check that the 31 degree mark aligns with the rotor tooth between 6,400 and 8,000 rpm.

### CAUTION

*Do not allow engine speed to exceed 8,000 rpm or engine damage may result.*

Replace the advancer assembly if it is not functioning properly.

Install the pulser cover.

## THROTTLE OPERATION

Make sure that there is no deterioration, damage, or kinks in the throttle cables, and that the throttle grip free play is 2-6 mm (1/8-1/4 in) on the outer edge of the throttle grip flange.

Check for smooth throttle grip rotation from fully closed to fully open in all steering positions and that it automatically returns to "fully closed" when released. Adjust if necessary.

Major adjustments are made at the middle adjuster. To adjust, loosen the grip play adjuster lock nut and turn the adjuster. Tighten the lock nut.

Minor adjustments are performed at the upper adjuster.

Recheck throttle operation.

Replace any damaged parts.

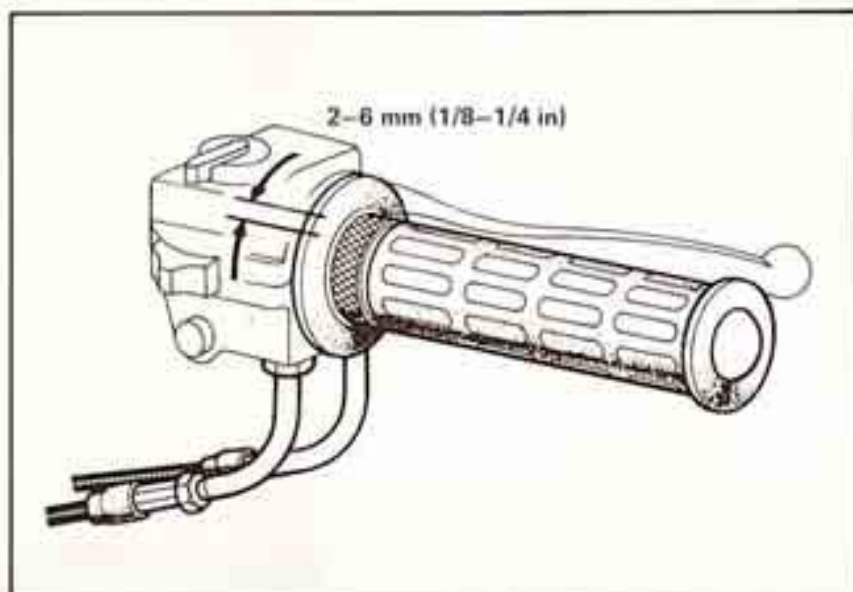
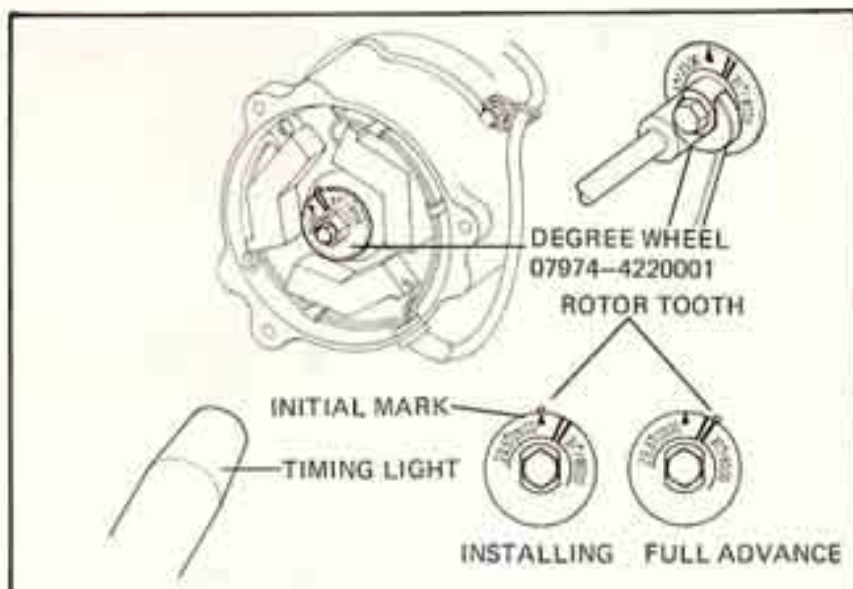





### CARBURETOR SYNCHRONIZATION

#### NOTE

Perform carburetor synchronization with engine at normal operating temperature, transmission in neutral and motorcycle on the center stand.

Remove the seat and air cleaner inlet duct. Turn the fuel valve OFF and remove the fuel tube and fuel tank. Prepare a longer fuel tube and reconnect it to the fuel tank and carburetor.



Position the fuel tank higher than its normal position.

Remove vacuum plugs from the carburetor and install long adapters to inner carburetors and short adapters to outer carburetors. Connect vacuum gauges.

Start the engine and adjust the idle speed to  $900 \pm 100$  rpm, then make sure that the maximum difference in vacuum readings is within 40 mmHg (1.6 inHg).





## ADJUSTMENT

### NOTE

The No.4 carburetor cannot be adjusted; it is the base.

Start the engine and adjust the idle speed.

**IDLE SPEED: 900 ± 100 rpm**

Make sure that the maximum difference in vacuum readings does not exceed 40 mmHg (1.6 inHg).

Adjust by turning the adjusting screws with the special tool "Carburetor Throttle Wrench" to achieve a maximum difference in vacuum readings between cylinders of less than 40 mmHg (1.6 inHg).

Adjust in the following order:

#### CARBURETOR

No. 5 - No. 6

No. 3 - No. 2 - No. 1



Recheck the idle speed and synchronization.







## CHOKE MECHANISM MAINTENANCE

Operate the choke lever and check for smooth operation.

Pull the choke to "fully closed" and make sure that the choke lever is fully closed at the carburetors.

Adjust by loosening the choke wire clamp and removing the choke wire.

Retighten the clamp, holding the choke lever fully closed.



## IDLE SPEED ADJUSTMENT

### NOTE

Adjust idle speed after synchronizing carburetors. The engine must be warm for accurate idle adjustment. Ten minutes of stop-and-go driving is sufficient.

Warm up the engine, shift to NEUTRAL, and place the motorcycle on its center stand.

Turn the throttle stop screw as required to obtain the specified idle speed.

**IDLE SPEED: 900 ± 100 rpm**

### NOTE

Pilot screws are factory pre-set. Do not adjust the pilot screw unless the carburetors are overhauled.







## VALVE CLEARANCE

### NOTE

- Inspect and adjust valve clearance while the engine is cold. (Below 35°C, 95°F).
- Before removing the cylinder head cover, allow oil to drain from the cylinder head into the crankcase by placing the motorcycle on its side stand.

Remove the seat.

Turn the fuel valve OFF and remove the fuel tube and fuel tank.

Remove the No. 1 and No. 6 spark plugs.

Remove the cylinder head brackets.

Remove the tachometer cable.

Remove the tachometer gear cap and driver gear.

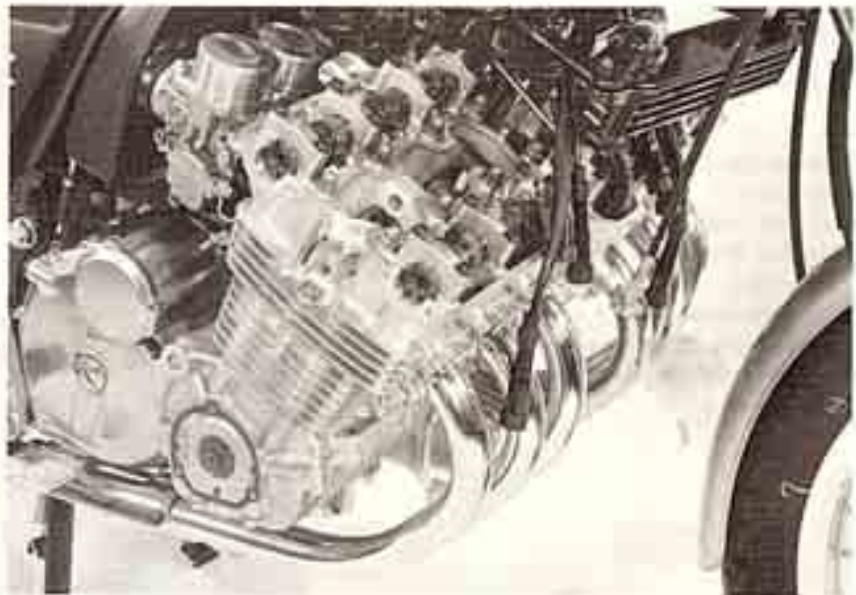

### CAUTION

*The tachometer driven gear must be removed to prevent No. 4 camshaft holder breakage when the camshafts are rotated. Camshaft holder breakage necessitates cylinder head assembly replacement.*

Remove the four cylinder head side covers. Remove the eight cylinder head cover mounting bolts and cylinder head cover.

### NOTE

- Do not allow engine oil to enter the combustion chambers when the cylinder head cover is removed.
- Make sure the torque of the camshaft holder mounting bolts (32 bolts) is 1.2–1.4 kg-m (104–122 in-lb).



Remove the right crank cap.

## INSPECTION

Measure intake and exhaust valve clearances by inserting a feeler gauge between the camshaft and valve lifter shim.

### VALVE CLEARANCE:

0.08 <sup>+0.05</sup>/<sub>-0.02</sub> mm (0.003 <sup>+0.0020</sup>/<sub>-0.0008</sub> in)

Rotate the crankshaft clockwise and measure the valve clearances in the following sequence:

- Open No. 2 Ex. Valves to maximum and Measure No. 2 In., No. 1 Ex., No. 3 Ex. clearance
- Open No. 4 Ex. Valves to maximum and Measure No. 4 In., No. 5 Ex., No. 6 Ex. clearance
- Open No. 2 In. Valves to maximum and Measure No. 1 In., No. 3 In., No. 5 In. clearance
- Open No. 5 Ex. Valves to maximum and Measure No. 6 In., No. 2 Ex., No. 4 Ex. clearance

Record the valve clearances.



### ADJUSTMENT

#### NOTE

Adjustment shims are available in 0.05 mm increments, from 2.30 to 3.50 mm.

Select a replacement shim to achieve the specified valve clearance, using the following procedures.

Rotate the valve lifter until the notch of the lifter appears on the shim so that the shim can be removed.

Rotate the crankshaft so that the valve being adjusted is at maximum lift.

Insert the special tool (Valve Lifter Holder) between the camshaft and two adjacent lifters.



#### CAUTION

*Do not rotate the crankshaft too far or in the wrong direction when the Valve Lifter Holder is depressing a pair of Valves. To do so will cause the intake and exhaust valves to strike and damage each other.*

VALVE LIFTER HOLDER  
07964-4220000

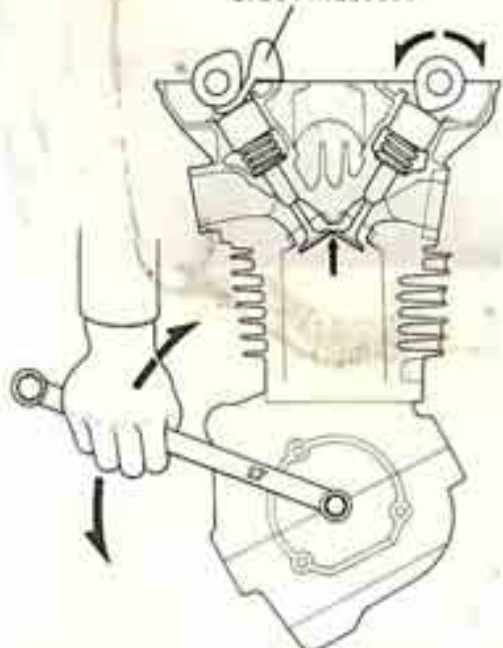

Rotate the crankshaft one turn in the proper direction, so that the cam lobe points away from the lifter.

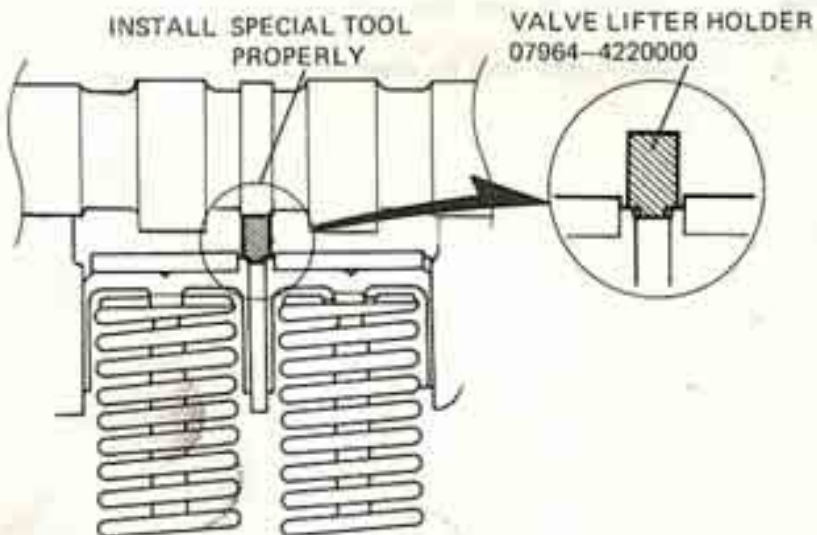





Remove the shim with tweezers.



Measure the thickness of used shim with a micrometer.  
 Select a replacement shim using the chart on Page 3-13.

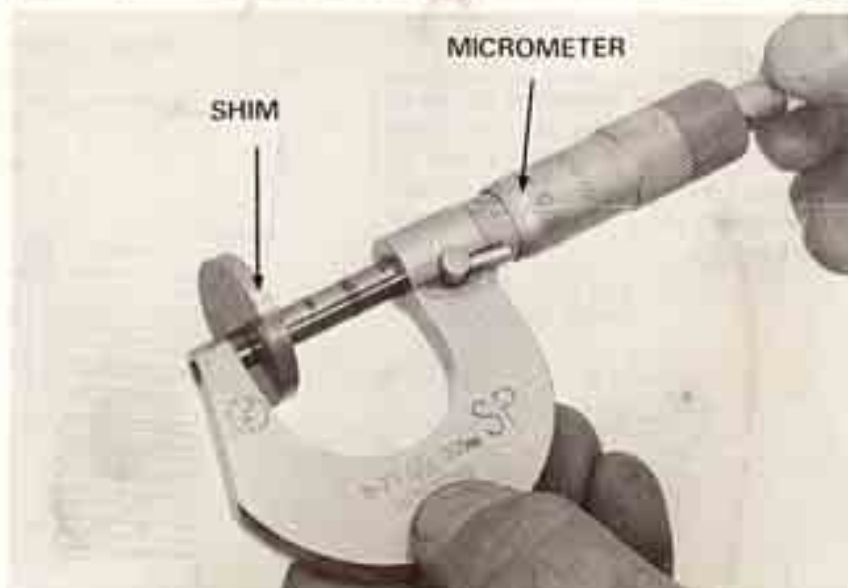

Insert the replacement shim.

**CAUTION**

*Make sure the opposite pair of valves does not open. The valves could be bent or damaged if the crankshaft is rotated incorrectly.*

Rotate the crankshaft one turn until the valves are at maximum lift.  
 Remove the special tool "Valve Lifter Holder".  
 Rotate the crankshaft 2-3 revolutions to fully seat the replacement shim.  
 Recheck the valve clearance.





EXAMPLE: 1. Measure valve clearance = 0.16 mm    3. Refer to chart. (See shaded columns)  
2. Measure present shim size = 2.50 mm    4. Replacement shim size = 2.55 mm

VALVE SHIM SELECTION CHART		STANDARD VALVE CLEARANCE = 0.08 +0.05 -0.02 mm																										
		PRESENT SHIM SIZE mm																										
VALVE CLEARANCE mm	SHIM mm	2.30	2.35	2.40	2.45	2.50	2.55	2.60	2.65	2.70	2.75	2.80	2.85	2.90	2.95	3.00	3.05	3.10	3.15	3.20	3.25	3.30	3.35	3.40	3.45	3.50		
		SPECIFIED CLEARANCE												NO CHANGE REQUIRED														
0.01-0.05																												
0.06-0.13																												
0.14-0.16																												
0.17-0.21																												
0.22-0.26																												
0.27-0.31																												
0.32-0.36																												
0.37-0.41																												
0.42-0.46																												
0.47-0.51																												
0.52-0.56																												
0.57-0.61																												
0.62-0.66																												
0.67-0.71																												
0.72-0.76																												
0.77-0.81																												
0.82-0.86																												
0.87-0.91																												
0.92-0.96																												
0.97-1.01																												
1.02-1.06																												
1.07-1.11																												
1.12-1.16																												
1.17-1.21																												
1.22-1.26																												
1.27-1.31																												

EX →

← EX

REPLACE WITH THIS SHIM

- NOTE**
- (1) Measure the valve clearance while the engine is cold.
  - (2) For shim replacement, see page 3-11.
  - (3) Measure old and new shims with a micrometer.
  - (4) The chart is for reference purpose only. After installing new shims, recheck the valve clearance. Before rechecking, rotate the camshafts several times to seat the shims in the lifters.
  - (5) If the shim thickness required exceeds 3.5 mm, there is carbon build-up on the valve seat. Remove the carbon and reface the seat.



## CAM CHAIN

Start the engine and allow it to idle.  
 Loosen the rear cam chain tensioner lock nut  
 1/2 turn.  
 Tighten the lock nut.

### NOTE

The tensioner will automatically position itself to provide the correct tension.

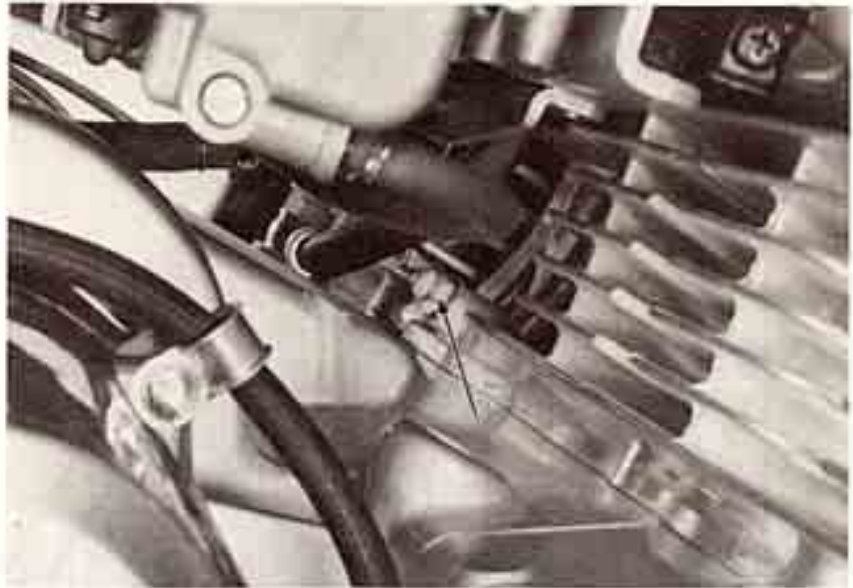

Loosen the front cam chain tensioner lock nut  
 and bolt 1/2 turn.  
 Tighten the bolt and lock nut.

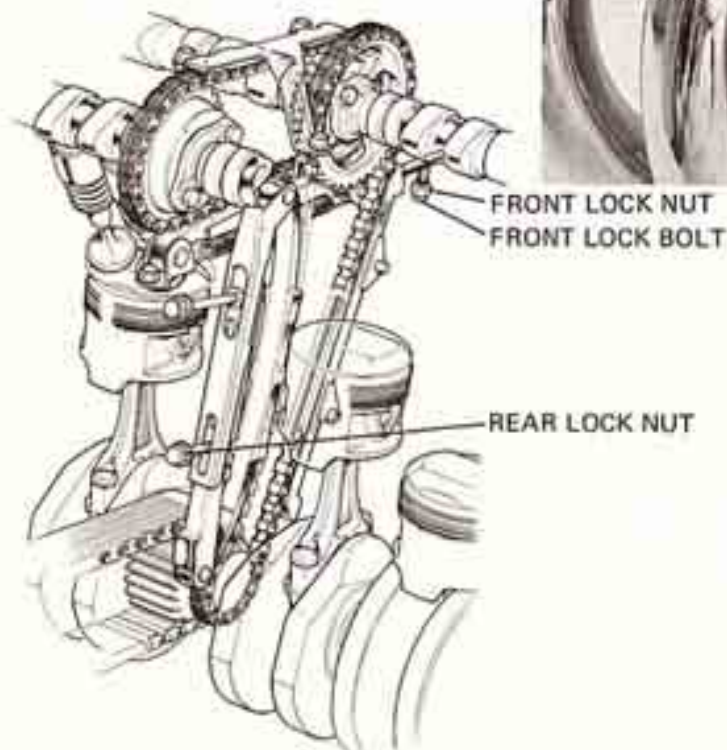
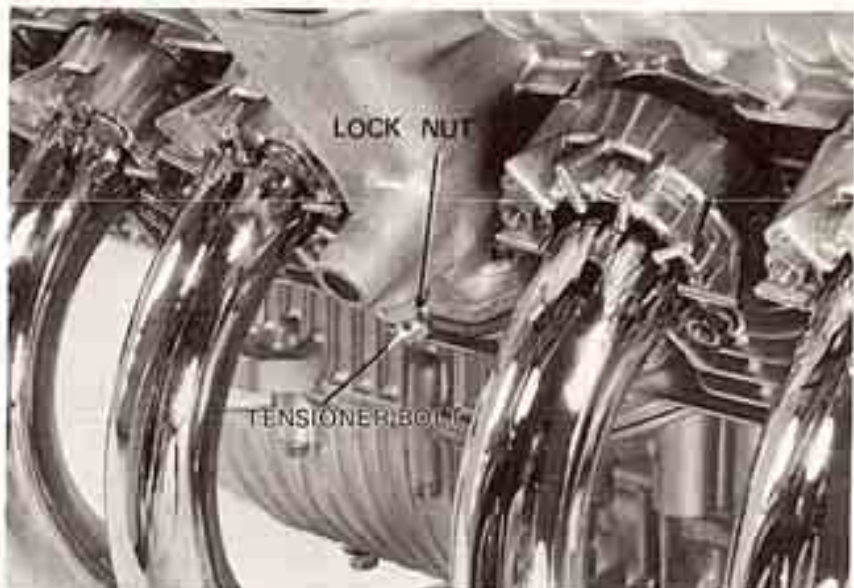





## COMPRESSION TEST

Warm up the engine.  
Remove all spark plugs.  
Insert the compression gauge.  
Open the choke and throttle valves fully.  
Crank the engine with the starter motor.

### NOTE

Crank the engine until the gauge reading stops rising. The maximum reading is usually reached in several seconds (electric starter).

### COMPRESSION PRESSURE:

$12 \pm 1 \text{ kg/cm}^2$  ( $170 \pm 14 \text{ psi}$ )

If compression is low, check the following:

- Leaky valves
- Improper valve clearance
- Leaking cylinder head gasket
- Worn piston/rings/cylinder

If compression is high, it indicates that carbon deposits have accumulated on the combustion chamber wall or on the piston crown.





## DRIVE CHAIN

### NOTE

Perform the following with the ignition switch "OFF".

Place the vehicle on its center stand and shift the transmission into neutral. Inspect the drive chain midway between sprockets on the lower chain run.

**FREE PLAY:** 15–25 mm (5/8–1 in)

**SERVICE LIMIT:** 40 mm (1.5 in)



### Adjust as follows:

Remove the rear axle cotter pin and loosen the nut.

Loosen the adjuster bolt lock nuts.

Turn the adjuster bolts an equal number of turns to obtain the specified free play.

### CAUTION

Be sure that the index mark aligns with the same graduation of the scale on both sides.

Tighten the adjuster bolt lock nuts.

Tighten the axle nut and install a new cotter pin.

Recheck free play and free wheel rotation. Lubricate the drive chain (Page 2-5).

### AXLE NUT TORQUE:

8.0–10.0 kg-m (58–72 ft-lb)

Replace the drive chain when the red zone on the label aligns with the rear of the swing arm with a free play of 20 mm (3/4 in).

Replacement chain: RK 630B0 or DID 630ZL

Inspect the sprocket teeth for excessive wear or damage.

Replace if necessary.

### NOTE

Never install a new drive chain on worn sprockets or a worn chain on new sprockets. Both chain and sprockets must be in good condition or the replacement chain or sprockets will wear rapidly.

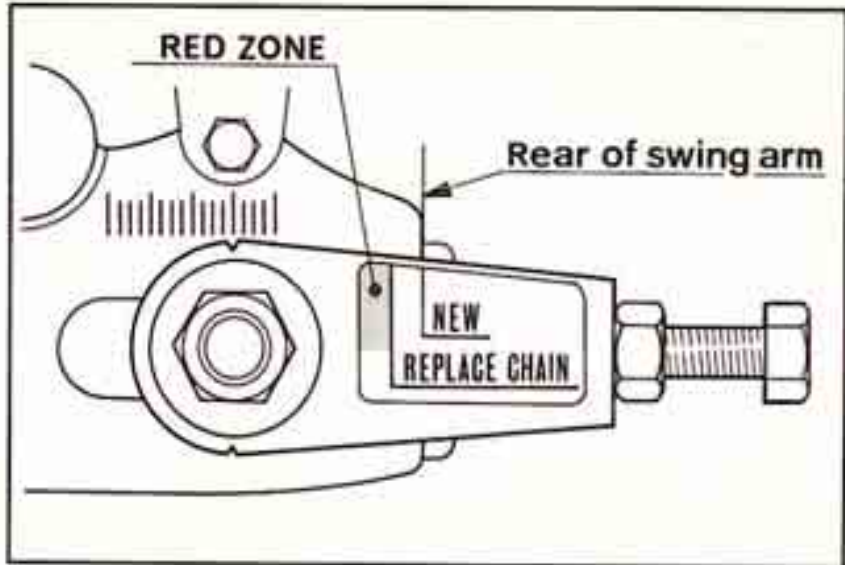





### BATTERY

Remove the right and left side covers.  
 Disconnect the ground cable at the battery terminal.  
 Disconnect the positive cable at the magnetic switch terminal.  
 Remove the battery.

Inspect the battery fluid level.  
 When the fluid level nears the lower level, refill with distilled water to the upper level.

#### NOTE

Add only distilled water. Tap water will shorten the service life of the battery.

#### WARNING

*The battery electrolyte contains sulfuric acid. Protect your eyes, skin and clothing. In case of contact, flush thoroughly with water and call a doctor if your eyes were exposed.*

Replace the battery, if sulfation forms or sediments accumulate on the bottom.

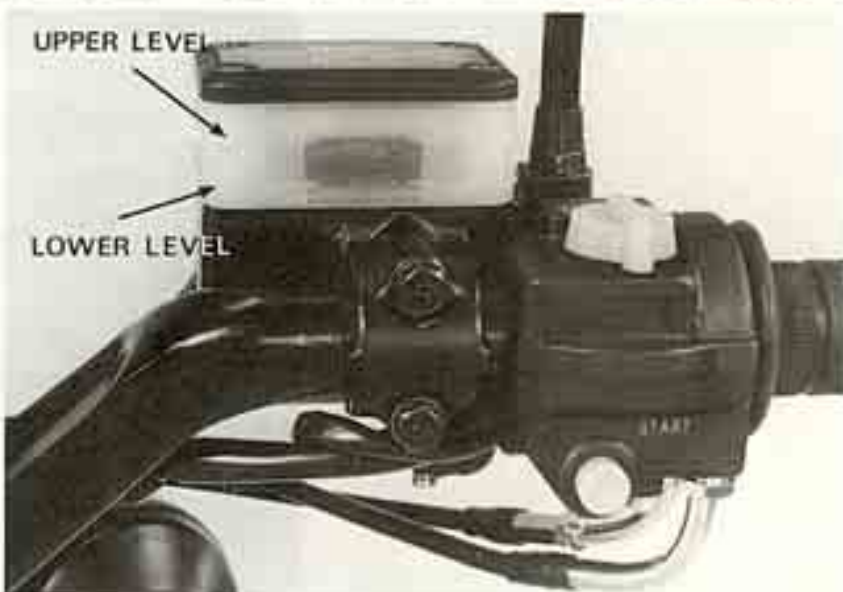

### BRAKES

#### BRAKE FLUID

Check that the front and rear brake fluid reservoirs are filled to the upper level mark.  
 If the level nears the lower level mark, fill the reservoir with DOT-3 BRAKE FLUID to the upper level mark.  
 Check the entire system for leaks, if the level is low.

#### CAUTION

- Do not mix different brands of fluid as they may not be compatible.
- Do not remove the cap until the handlebar has been turned full right so that the reservoir is level.
- Avoid operating the brake lever with the cap removed. Brake fluid will flow out if the lever is pulled.





## BRAKE PADS WEAR

Remove the cap from the caliper and check for brake pad wear.

Replace the brake pads if the red line on the top of the pads reaches the edge of the brake disc. (Refer to Section 12).

**CAUTION**

*Always replace the brake pads in pairs to assure even disc pressure.*

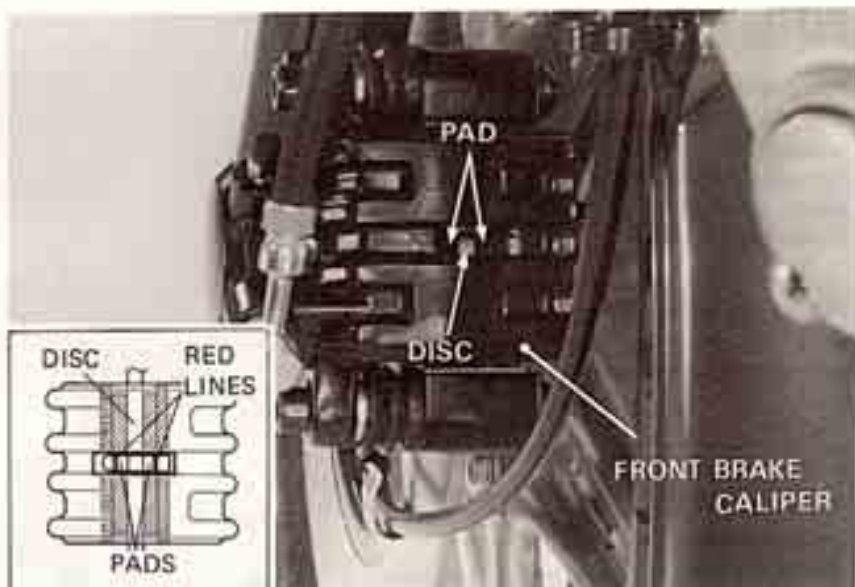
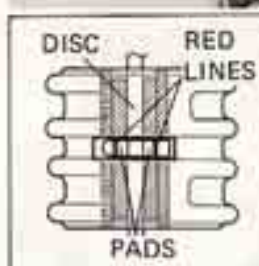

## BRAKE SYSTEM

### REAR BRAKE PEDAL HEIGHT

Adjust the pedal height so that the distance between the pedal and upper face of the footpeg is 7 mm (0.27 in).

**CAUTION**

*Improper brake pedal height adjustment can cause brake drag.*







Adjust as follows:

Loosen the lock nut.

Turn the adjuster until the correct pedal height is obtained.

Tighten the lock nut securely.

### NOTE

After adjusting pedal height, adjust the brakelight switch.

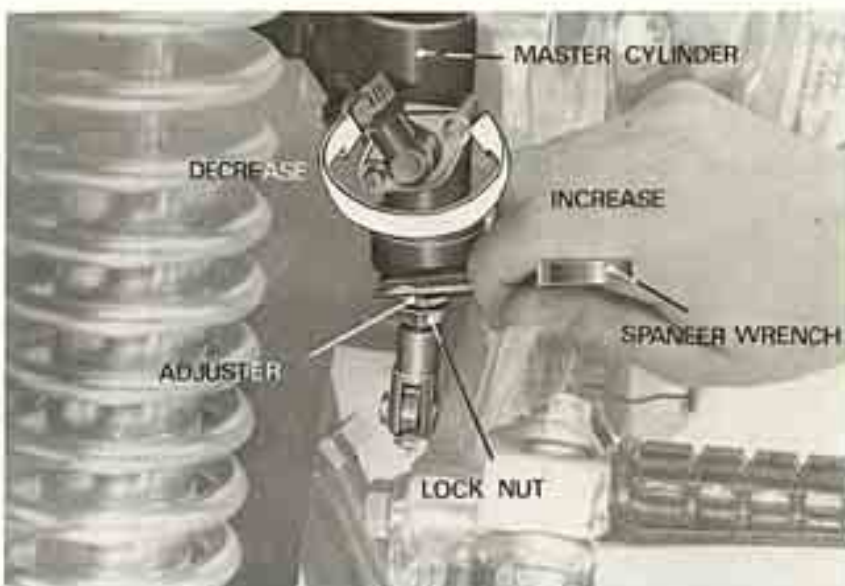

## BRAKELIGHT SWITCH

Adjust the brakelight switch so that the brakelight will light when the brake pedal is depressed and the brake begins engagement.

### NOTE

Do not turn the switch body. The front brakelight switch does not require adjustment.

Adjust by bending the switch adjusting nut as shown.

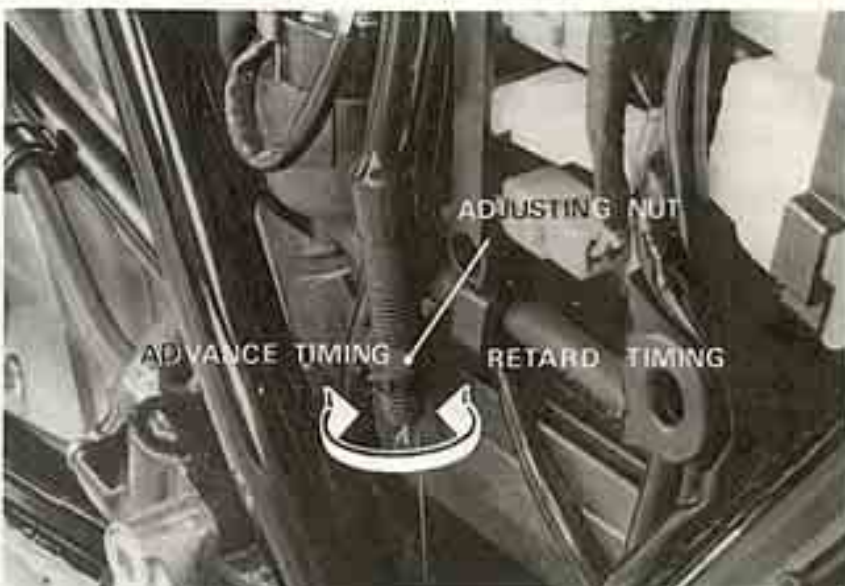

## HEADLIGHT AIM

Adjust vertically by loosening both headlight case mounting bolts.

Adjust horizontally by turning the adjusting screw on the headlight rim.

Turn the adjusting screw clockwise to direct the beam toward the right side of the rider.

### NOTE

Adjust the headlight beam as specified by local laws and regulation.

### WARNING

*An improperly adjusted headlight may blind oncoming drivers, or it may fail to light the road for a safe distance.*

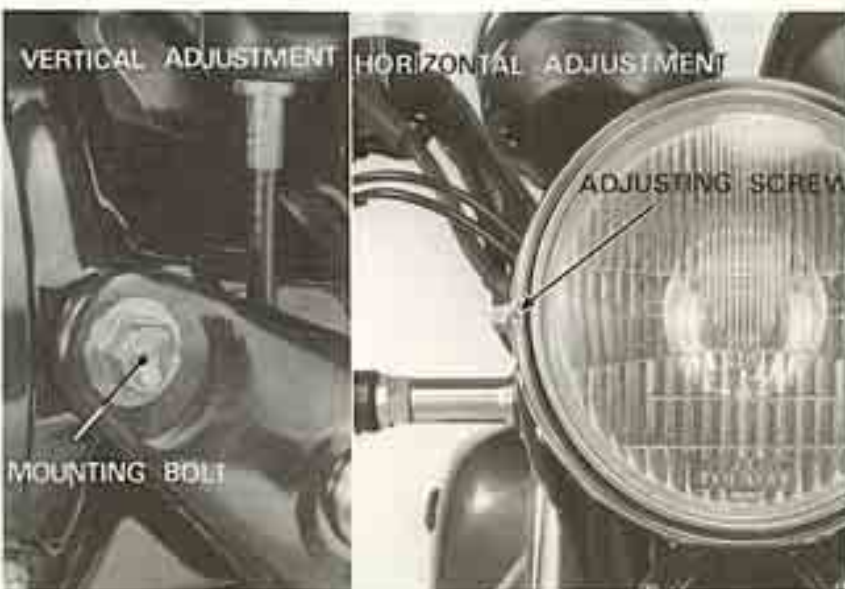



## CLUTCH FREE PLAY

Inspect the clutch lever free play at the end of the lever.

**FREE PLAY: 10–20 mm (3/8–3/4 in)**

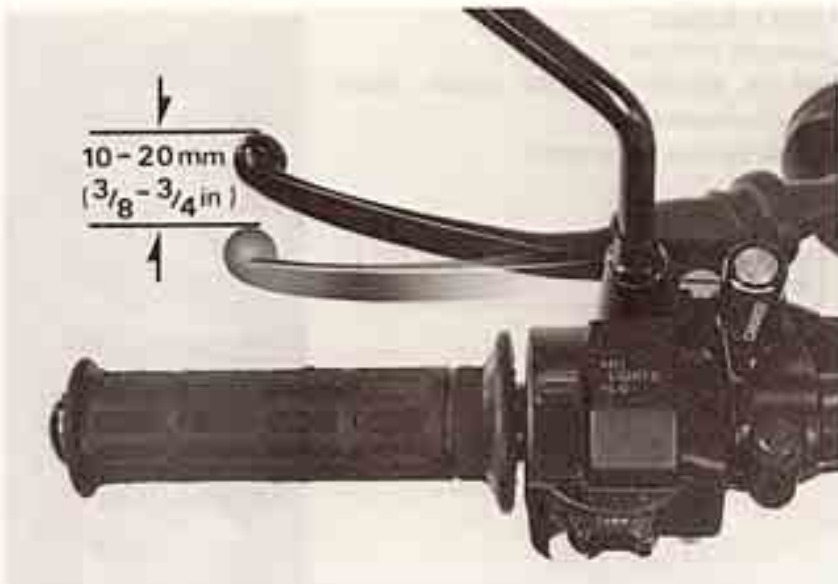

## ADJUSTMENT

Loosen the upper adjusting bolt's lock nut and turn the adjusting bolt until the correct free play is obtained.

Tighten the lock nut.

### NOTE

Do not expose the adjusting bolt threads more than 8 mm (3/4 in).

If adjustment cannot be made with the clutch lever adjusting bolt, screw the adjusting bolt all the way in. Adjustment must be made at the clutch housing.

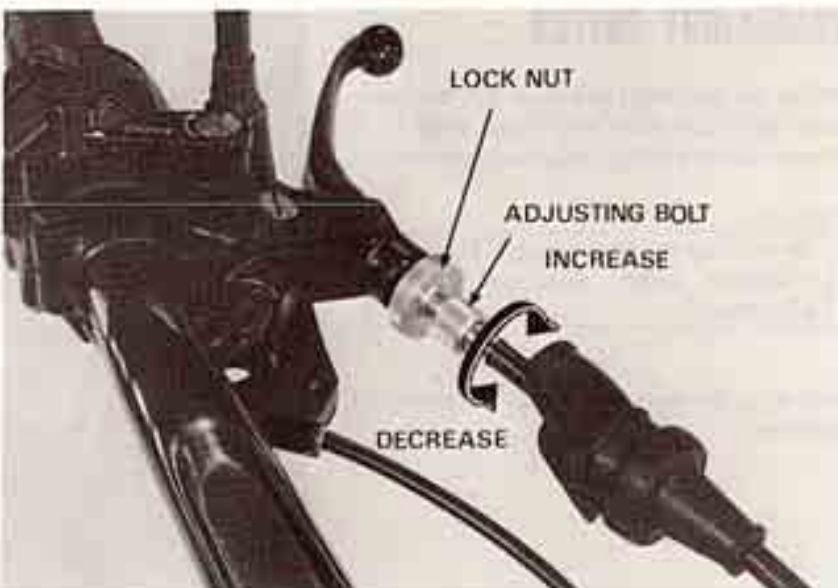

Loosen the lower clutch cable adjusting lock nut and turn the adjusting nut all the way in.







Remove the clutch lifter cap, loosen the clutch lifter lock nut. Turn the adjusting screw in until a slight resistance is felt. From this position, turn the clutch adjusting screw counterclockwise 1 turn, and tighten the lock nut.

Turn the clutch cable lower adjusting nut so that there is 10–20 mm (3/8–3/4 in) of free play at the end of the clutch lever. Tighten the lock nut.

Any minor adjustment can be obtained with the adjusting bolt and lock nut at the clutch lever.

After adjustment, be sure all lock nuts are tightened securely.

Check to see that the clutch is not slipping and is properly disengaging.

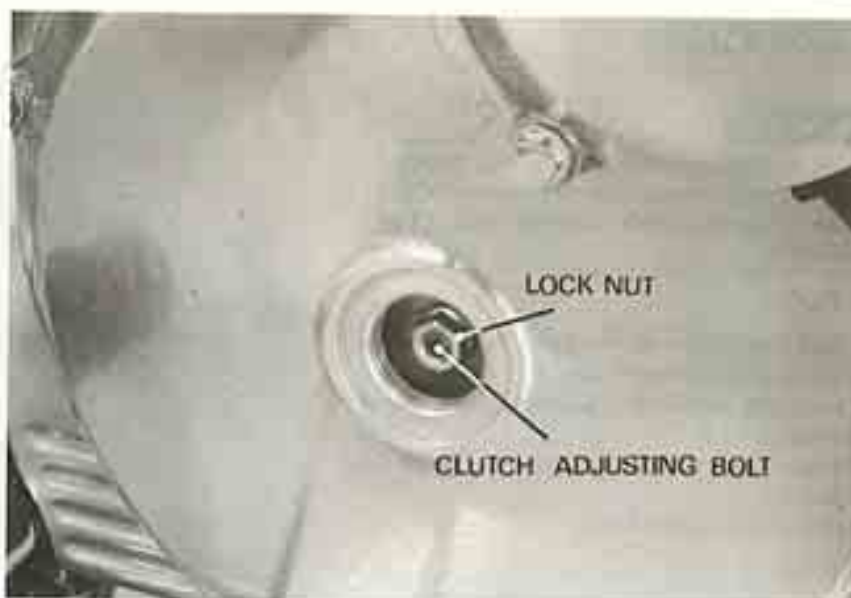

### SIDE STAND

Check the rubber pad for deterioration or wear.

Replace if any wear extends to the wear line as shown.

Check the side stand spring for damage and loss of tension, and the side stand assembly for freedom of movement and bending.



#### NOTE

When replacing, use a rubber pad with the mark "OVER 260 lbs ONLY". Spring tension is correct if the measurements fall within 1.5–2.5 kg (3.3–5.5 lb) when pulling the side stand lower end with a spring scale.

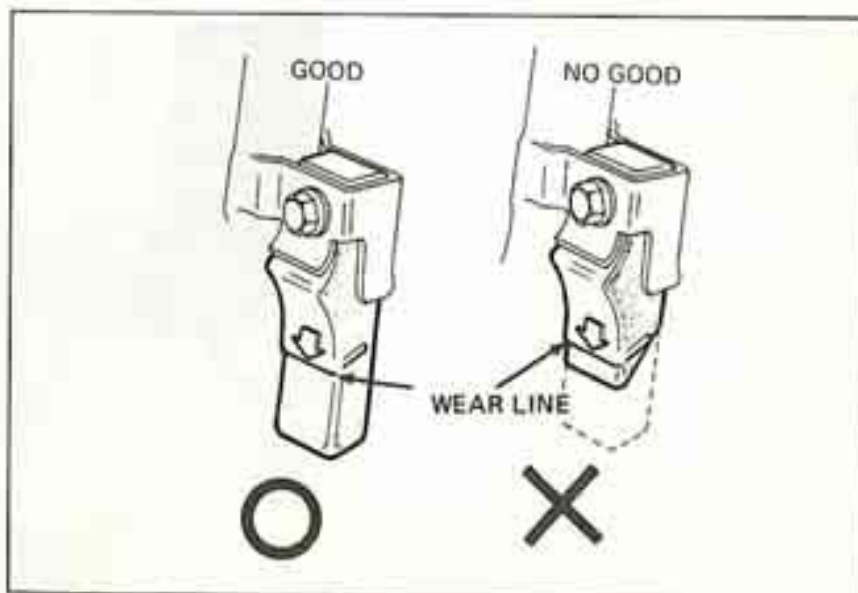



### SUSPENSION

#### WARNING

*Do not ride a vehicle with faulty suspension. Loose, worn or damaged suspension parts impair vehicle stability and rider control.*

#### FRONT

Check the action of the front forks by compressing them several times.

Check the entire fork assembly for leaks or damage.

Replace any components which cannot be repaired.

Tighten all nuts and bolts.

#### REAR

Place the motorcycle on its center stand.

Move the rear wheel sideways with force to see if the swing arm bushings are worn.

Replace if excessively worn.

Check the entire suspension assembly to see if it is securely mounted, and not damaged or distorted.

Tighten all nuts and bolts.

Lubricate the swing arm bushings.



### WHEELS

#### TIRE PRESSURE

##### NOTE

Tire pressure should be checked when tires are **COLD**.

Check the tire for cuts, imbedded nails, or other sharp object.

Recommended tire pressure and tire size:

Cold tire pressure kg/cm <sup>2</sup> (psi)	Front 2.0 (28) Rear 2.8 (40)
Vehicle capacity load limit	163 kg (360 lbs)
Tire size	Front 3.50H19-4PR Rear 4.25H18-4PR
Tire brand Tubeless only	Front GOLD SEAL F11 (DUNLOP) M&G. MOPUS-S703 (BRIDGESTONE) Rear GOLD SEAL K127 (DUNLOP) M&G. MOPUS-G504 (BRIDGESTONE)



Check the front and rear wheels for trueness (page 14-5).





## STEERING HEAD BEARINGS

### NOTE

Check that the control cables do not interfere with the handlebar rotation.

Raise the front wheel off the ground.  
Check that the handlebar rotates freely.  
If the handlebar moves unevenly, binds, or has vertical movement, adjust the steering head bearing by turning the steering head adjusting nut with a pin spanner. (page 13-27)



## NUTS, BOLTS, FASTENERS

Check that all chassis nuts and bolts are tightened to correct torque values.  
Check all cotter pins and safety clips.

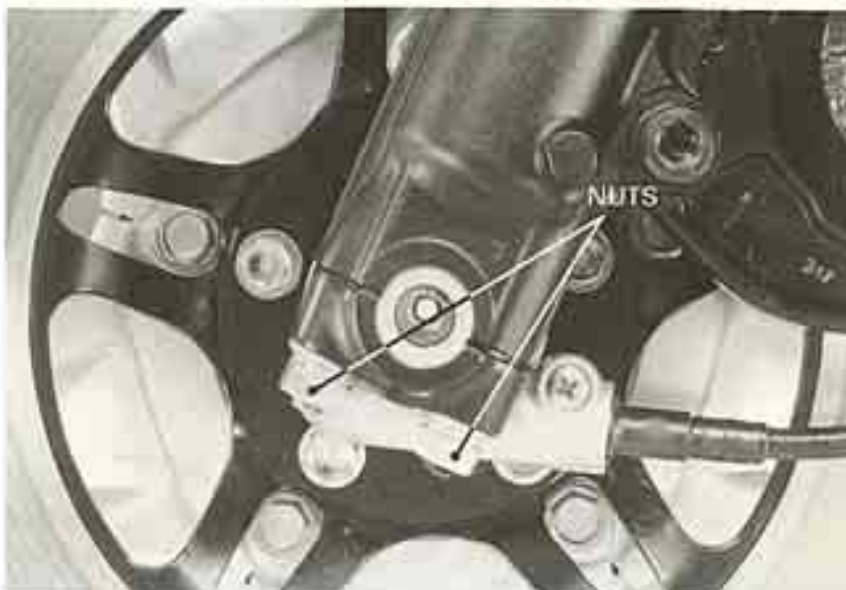



FUEL SYSTEM

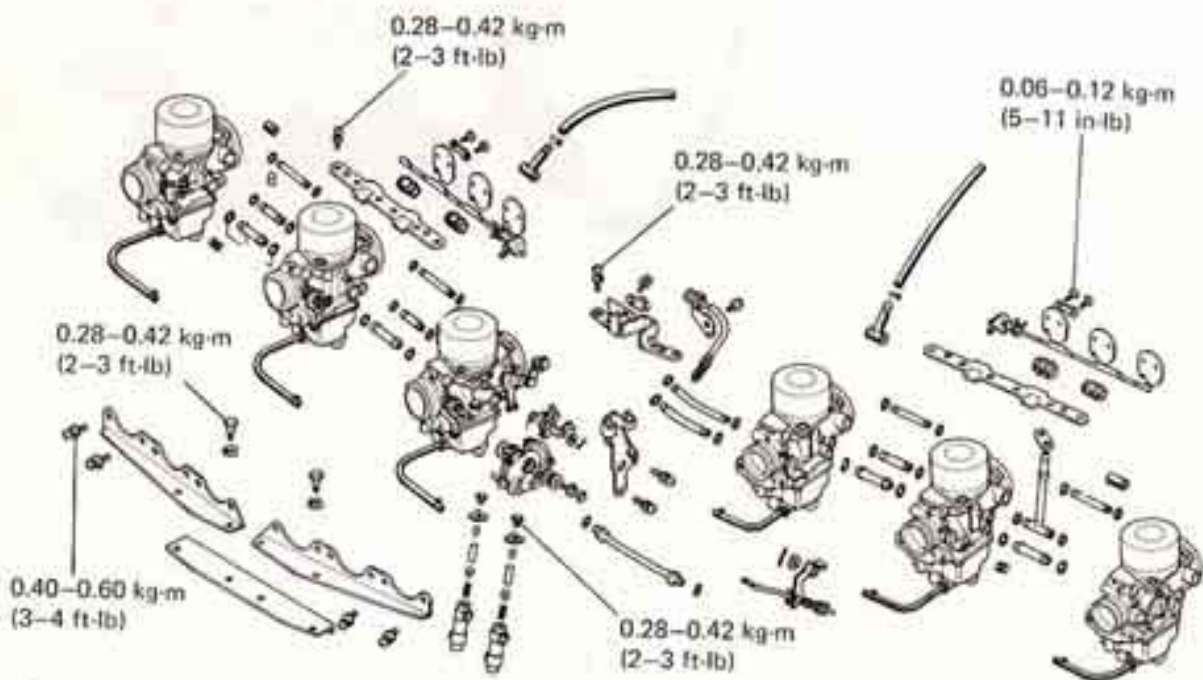
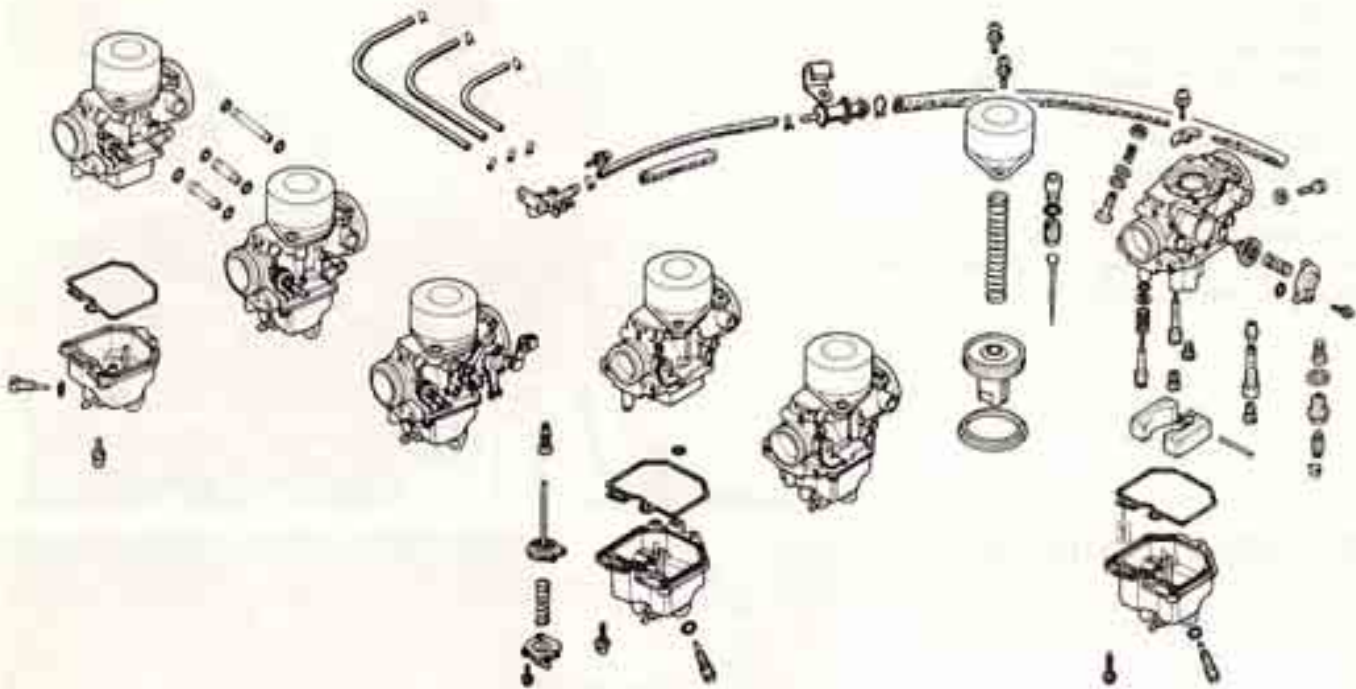





SERVICE INFORMATION	4-1	FLOAT LEVEL ADJUSTMENT	4-9
TROUBLESHOOTING	4-2	CARBURETOR SEPARATION	4-9
CARBURETOR REMOVAL	4-3	LINKAGE DISASSEMBLY	4-14
VACUUM CYLINDER DISASSEMBLY	4-5	CARBURETOR ASSEMBLY	4-15
FLOAT CHAMBER DISASSEMBLY	4-6	ACCELERATOR PUMP ADJUSTMENT	4-25
AIR CUTOFF VALVE DISASSEMBLY	4-7	PILOT SCREW ADJUSTMENT	4-26
ACCELERATOR PUMP DISASSEMBLY	4-8	FUEL TANK	4-27
COMPONENT ASSEMBLY	4-8	AIR CLEANER	4-27

## SERVICE INFORMATION

### WORKING PRACTICE

Use caution when working with gasoline. Always work in a well-ventilated area and away from sparks or open flames. When disassembling fuel system parts, note the locations of the O-rings. Replace them with new ones on re-assembly. The float bowls have drain plugs that can be loosened to drain residual gasoline.

### SPECIAL TOOLS

#### Common Tool

Float gauge 07401-0010000

#### Special Tools

Carburetor Throttle Wrench 07908-4220100

Carburetor Pilot Screw Wrench 07908-4220200

### TORQUE VALUES

Front bracket	0.40-0.60 kg-m (3-4 ft-lb)
Rear bracket	0.28-0.42 kg-m (2-3 ft-lb)
Choke valve	0.06-0.12 kg-m (5-11 in-lb)
Front and rear brackets between three carburetors	0.28-0.42 kg-m (2-3 ft-lb)
Throttle joint holding nut	0.28-0.42 kg-m (2-3 ft-lb)

### SPECIFICATIONS

Venturi dia.	28 mm (1.1 in)
Setting mark	V860A
Float level	15.5 mm (0.61 in)
Main jet	Pri.: 65 2nd: 98
Idle speed	900 ± 100 rpm
Throttle grip free play	2-6 mm (0.08-0.24 in)
Fast idle	2,000 ± 500 rpm (after break-in)
Pilot screw	See page 4-26



## TROUBLESHOOTING

### Engine Cranks but Won't Start

1. No fuel in tank
2. No fuel to carburetor
3. Engine flooded with fuel
4. No spark at plug (ignition malfunction)
5. Air cleaner clogged
6. Intake air leak
7. Improper choke operation
8. Improper throttle operation

### Hard Starting or Stalling after Starting

1. Improper choke operation
2. Ignition malfunction
3. Fast idle speed incorrect
4. Carburetor malfunction
5. Fuel contaminated
6. Intake air leak
7. Incorrect idle air/fuel mixture
8. Idle speed incorrect

### Rough Idle

1. Ignition malfunction
2. Idle speed incorrect
3. Incorrect carburetor synchronization
4. Incorrect carburetor air/fuel mixture
5. Carburetor malfunction
6. Fuel contaminated

### Misfiring during Acceleration

1. Ignition malfunction
2. Incorrect carburetor air/fuel mixture
3. Faulty air cutoff valve or accelerator pump

### Backfiring

1. Ignition malfunction
2. Incorrect carburetor air/fuel mixture
3. Carburetor malfunction
4. Faulty air cutoff valve or accelerator pump

### Poor Performance (Driveability) and Poor Fuel Economy

1. Fuel system clogged
2. Ignition malfunction
3. Incorrect carburetor air/fuel mixture
4. Faulty accelerator pump

### Lean Mixture

1. Clogged fuel jets
2. Piston stuck closed
3. Faulty float valve
4. Float level low
5. Fuel cap vent blocked
6. Fuel strainer clogged
7. Restricted fuel line
8. Air vent tube clogged
9. Intake air leak
10. Pilot screw misadjusted

### Rich Mixture

1. Clogged air jets
2. Faulty float valve
3. Float valve too high
4. Choke stuck closed
5. Pilot screw misadjusted
6. Stuck closed air cutoff valve
7. Clogged air cleaner





## CARBURETOR REMOVAL

### NOTE

To remove the carburetors, the engine must be tilted.  
Refer to Section 5 "ENGINE REMOVAL AND INSTALLATION".

Disconnect the throttle cables at the throttle grip housing before tilting the engine.

Remove the choke cable at left handlebar switch housing.



Loosen the air cleaner connecting band.  
(For more information, refer to Section 5).

Tilt the engine.



Loosen the carburetor manifold bands.  
Remove the carburetor assembly with the chamber.

### NOTE

For easy removal, loosen the cylinder head side bands.

### CAUTION

Apply equal force to each carburetor.





Remove the chamber from the carburetor.

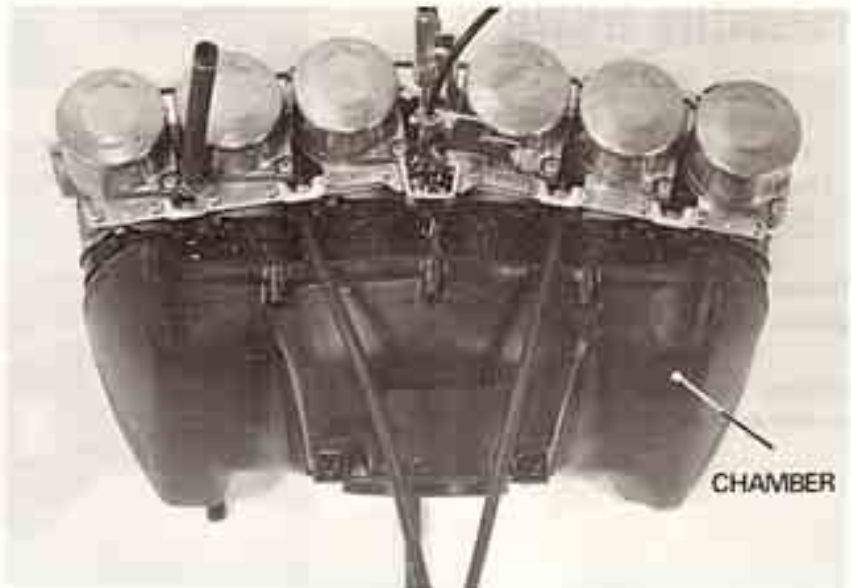

Disconnect the throttle and choke cables.

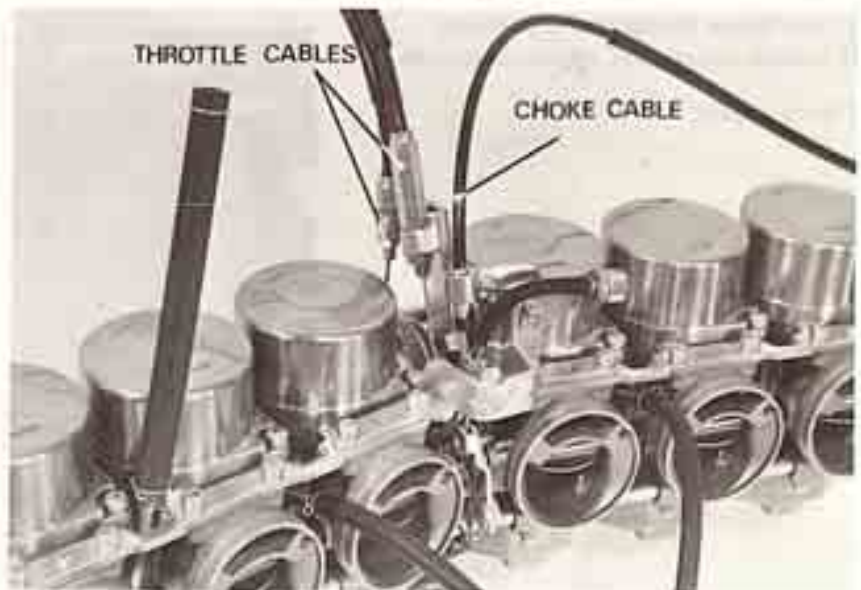

Drain the fuel by loosening each drain screw.

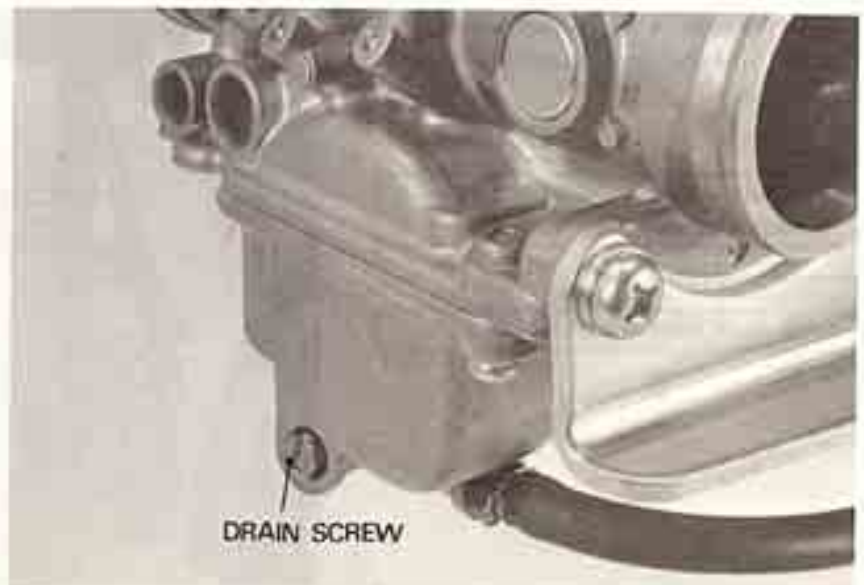





### VACUUM CYLINDER DISASSEMBLY

Remove the vacuum cylinders from the carburetor bodies.

Carefully lift the vacuum piston out with the needle and compression spring.

#### NOTE

Inspect the vacuum piston and cylinder for wear, nicks, scratches or other damage. Make sure that the piston and jet needle move up and down freely in the cylinder.

Remove the full open stopper.  
Remove the needle set screw.  
Separate the jet needle from the piston.

#### NOTE

Inspect the needle and seat for deposits, bending, grooves, or other damage.

Carefully lift the seal ring off the carburetor body.  
Remove the air jet cover.

Blow open the primary main air jet, secondary main air jet and slow air jet with compressed air.

#### NOTE

Never clean carburetor jets with wire or drills. This will enlarge the openings and result in excessive fuel consumption.

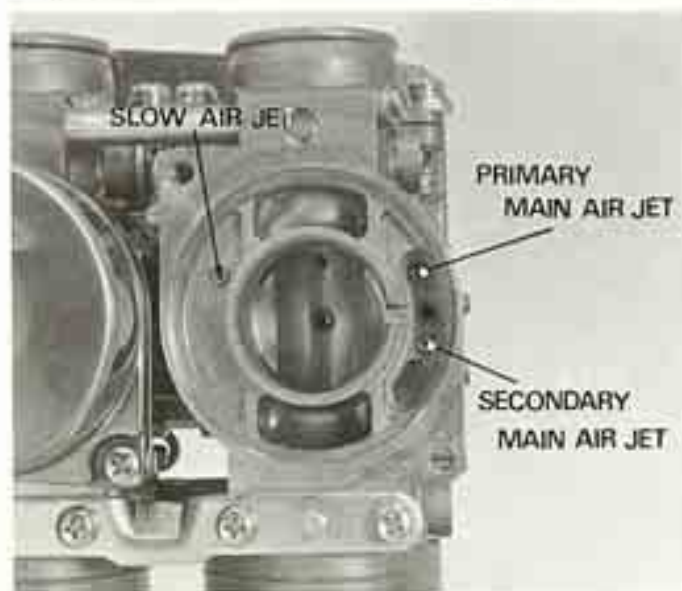
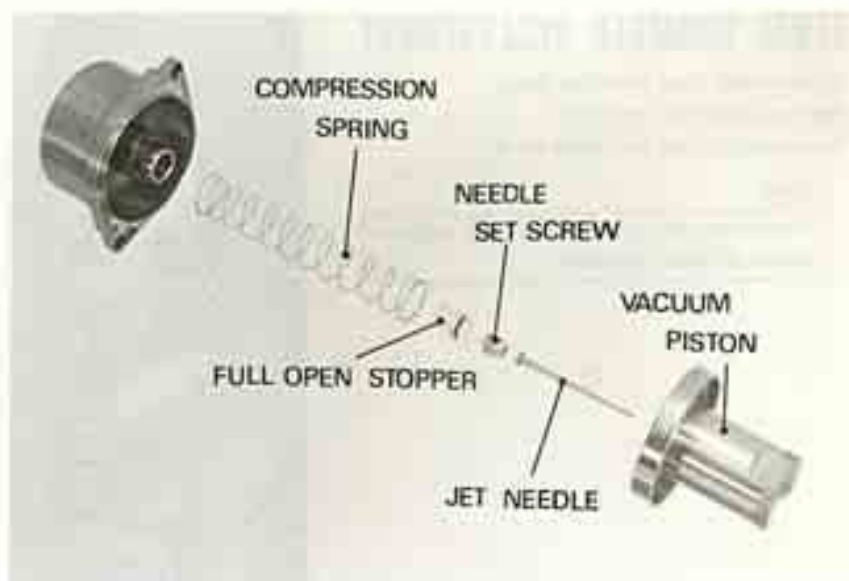



## FLOAT CHAMBER DISASSEMBLY

Remove the float chamber body.  
 Remove the float arm pin.  
 Remove the float and float valve.

### NOTE

Remember the direction of the clip to ensure original assembly.

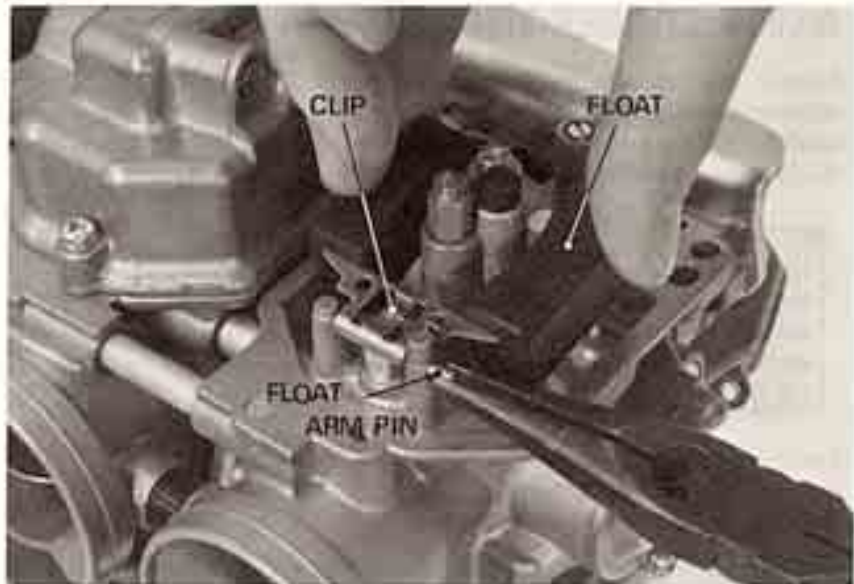

Inspect the float valve and seat for grooves, nicks or deposits.  
 Inspect the float valve for operation.

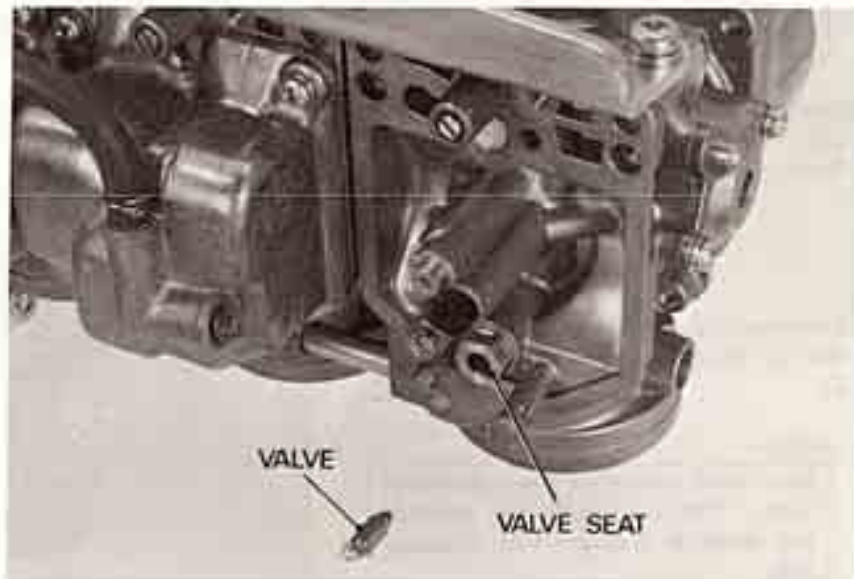

Remove the secondary main jet.  
 Remove the primary main jet.  
 Remove the slow jet plug.







### NOTE

The slow jet cannot be removed, it is a press fit.

Remove the primary nozzle.

Remove the needle jet holder.

Tilt the carburetor to remove the needle jet.

Blow all jets and body passages with compressed air.

### NOTE

- If the needle jet is difficult to remove, carefully press the needle jet from the cylinder side with a soft material stick.

- Before removing the pilot screw, record the number of turns until it seats. Do not damage the pilot screw threads when removing the plain washer and O-ring.

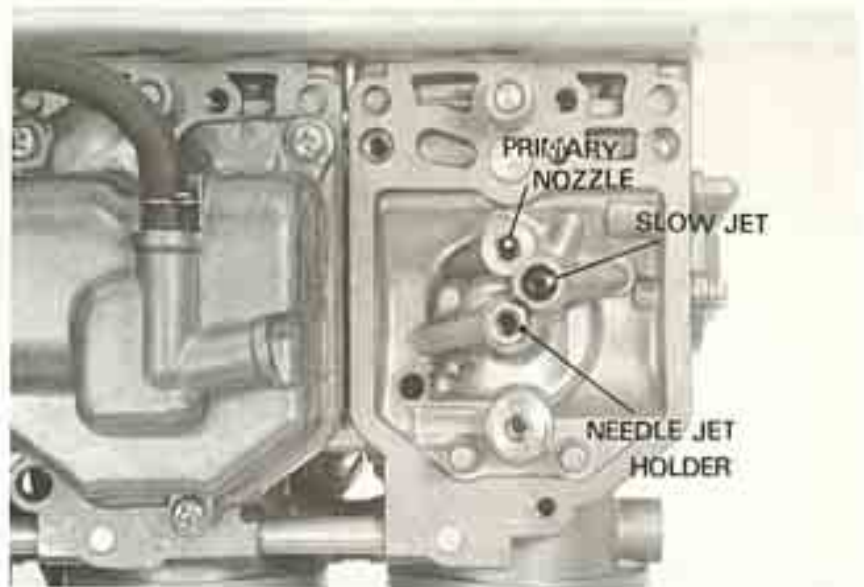

## AIR CUTOFF VALVE DISASSEMBLY

Remove the air cutoff valve cover and spring.

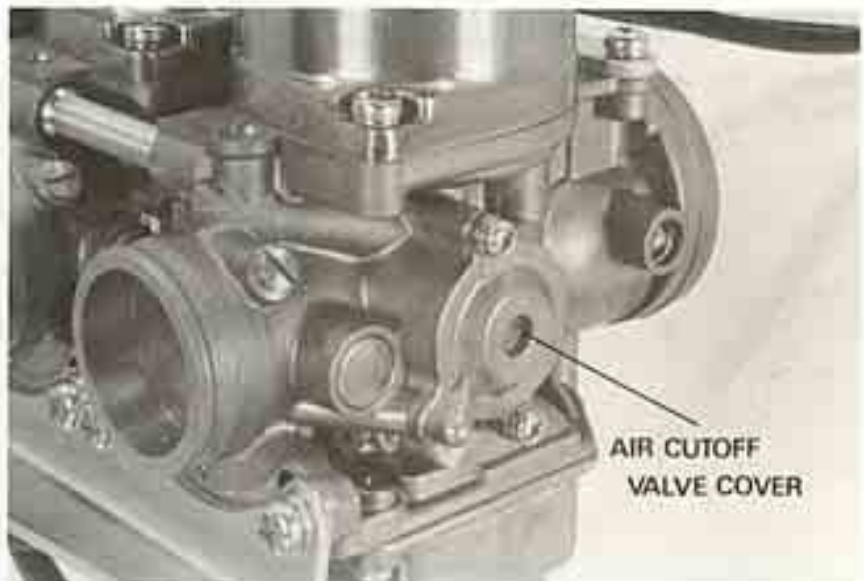

Remove the diaphragm and O-ring.

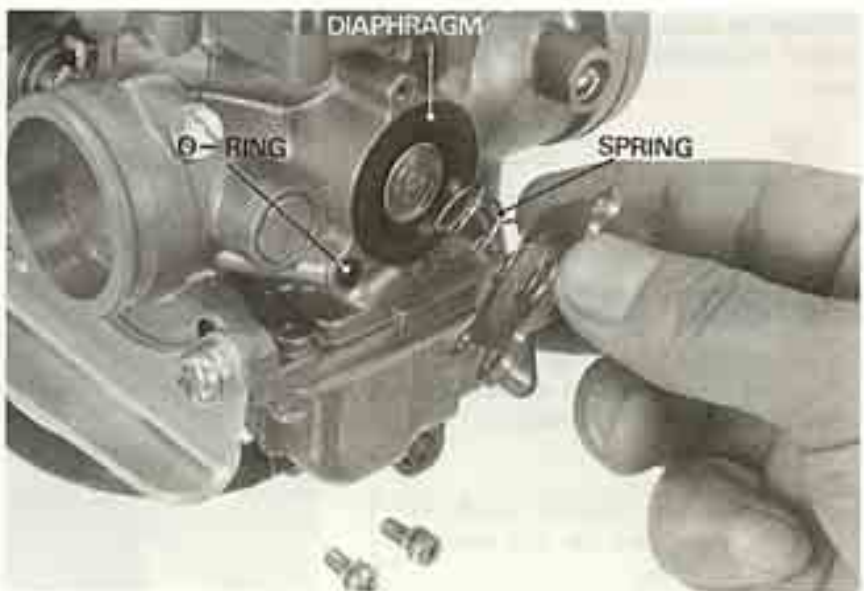



**FUEL SYSTEM**

Inspect the diaphragm and valve for cracks and brittleness.

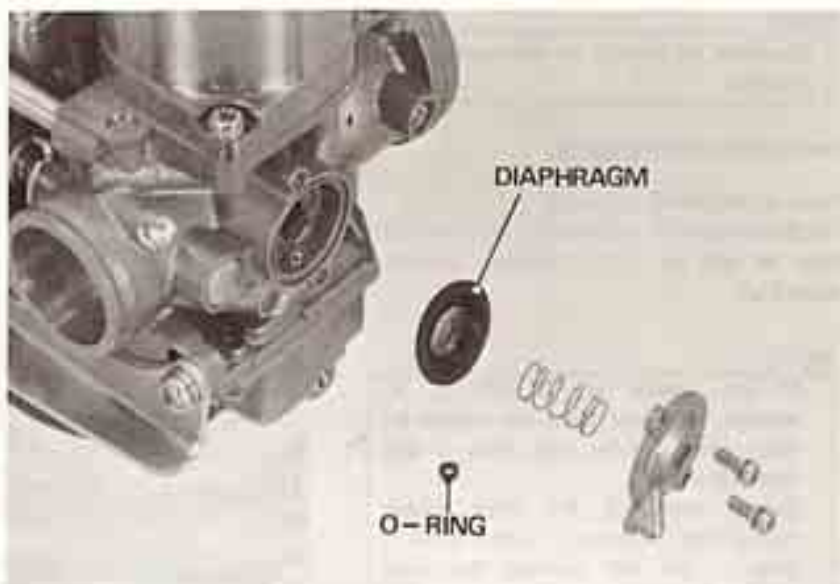

**ACCELERATOR PUMP DISASSEMBLY**

Remove the accelerator pump cover and spring.

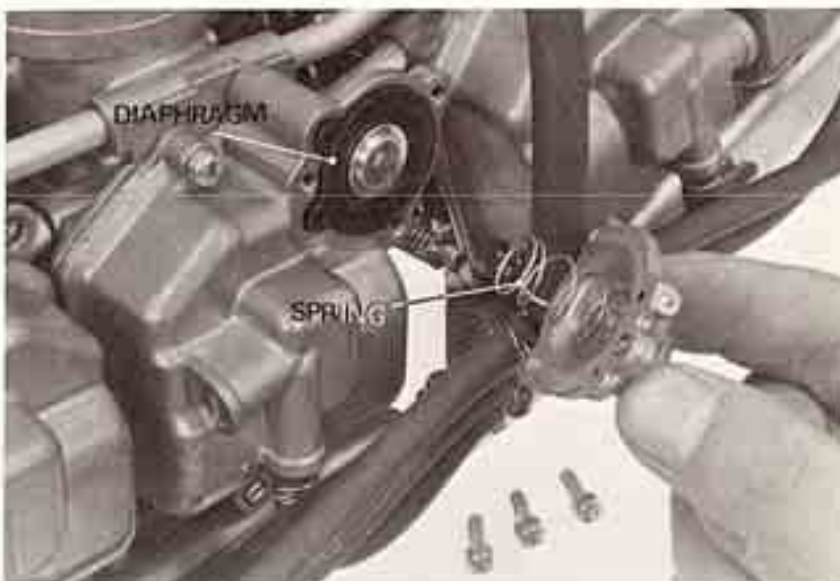

Remove the diaphragm.  
Inspect the diaphragm for cracks and brittleness.

**NOTE**

Be sure the rod is not bent.

**COMPONENT ASSEMBLY**

To assemble the accelerator pump, air cutoff valve, float chamber and vacuum cylinder, reverse the disassembly procedure.

**NOTE**

When installing the air cutoff valve O-ring, make sure the flat surface is toward the body.







## FLOAT LEVEL ADJUSTMENT

Adjust the float level by bending the float arm carefully until the float tip just contacts the float valve.

**FLOAT LEVEL:** 15.5 mm (0.61 in)

### NOTE

Before adjusting, remove the adjacent chambers.

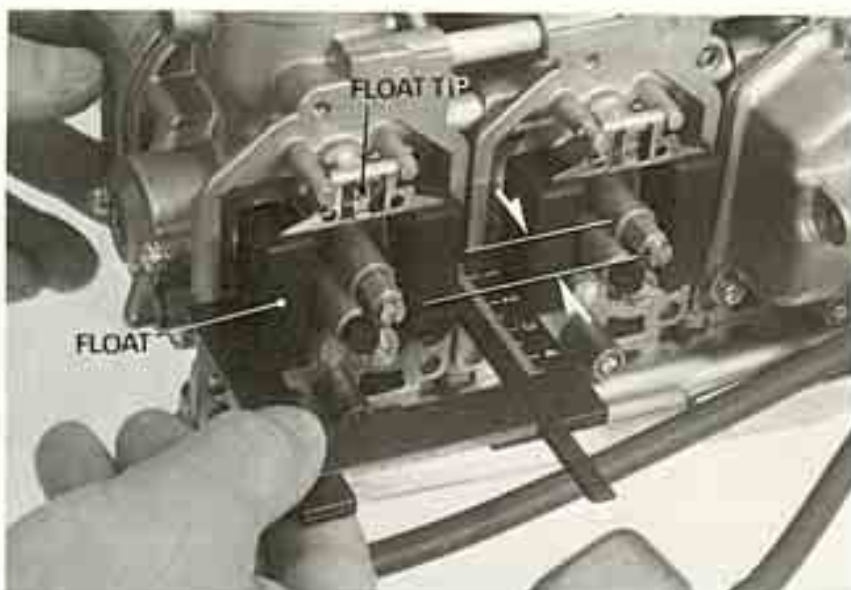

## CARBURETOR SEPARATION

Disconnect the overflow tubes from the float chambers.



Remove the cotter pin from the accelerator pump rod.  
Remove the plain washer, spring and spring collar.

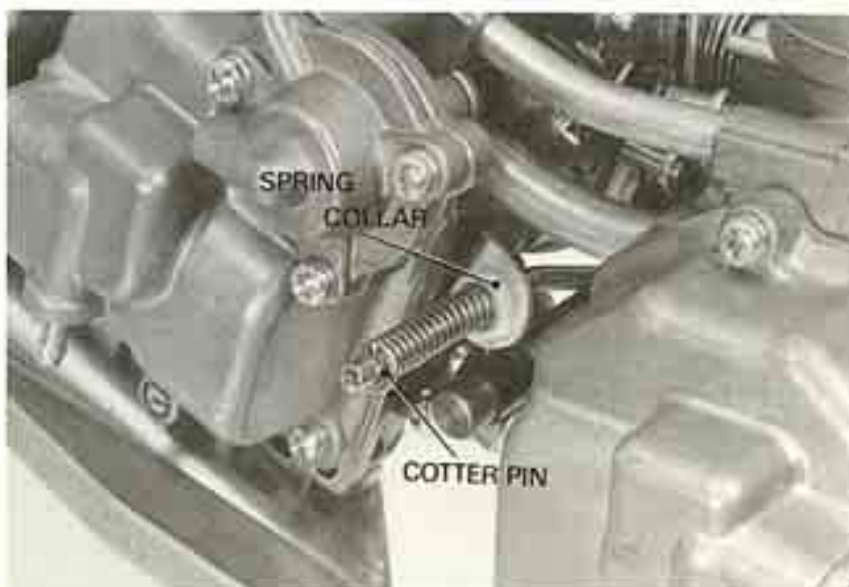



Remove the throttle stop screw holder.  
Turn the throttle stop screw out.

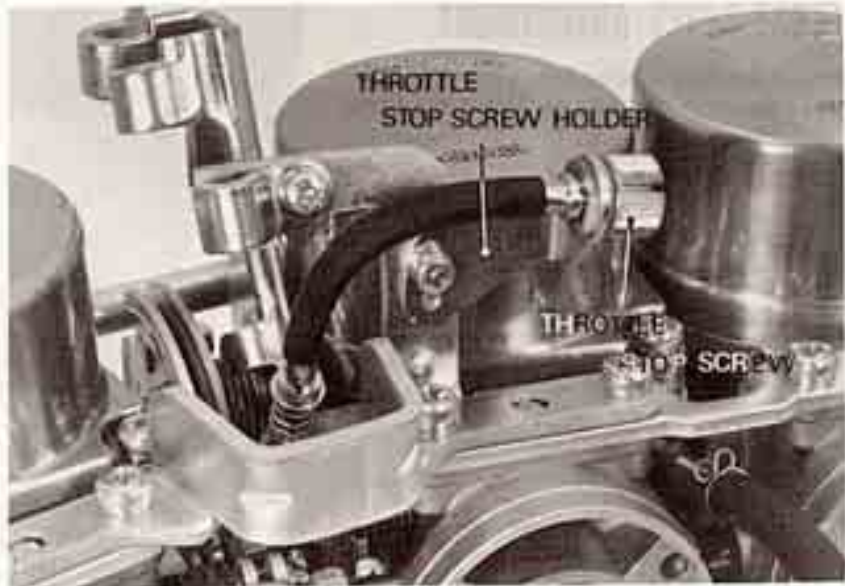

Fold the throttle joint bolt locking washer tabs down.

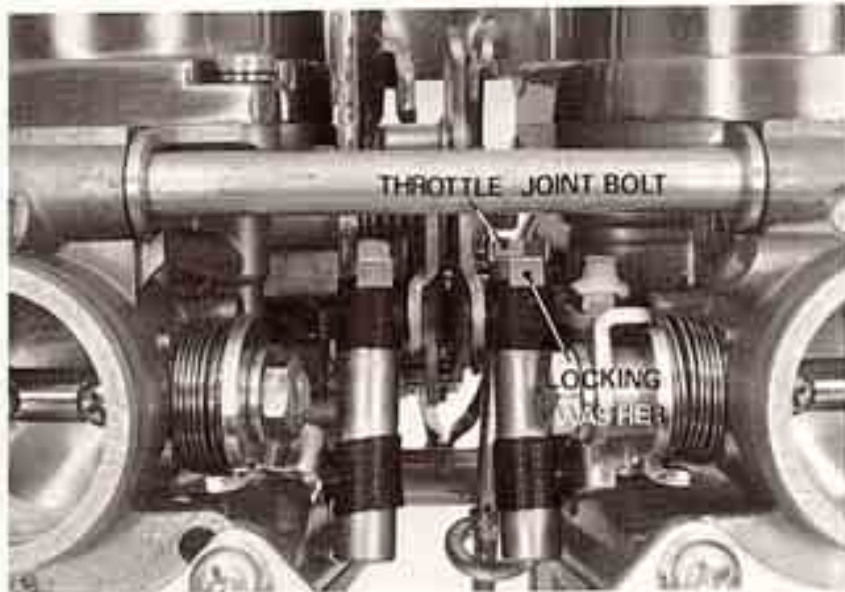

Loosen the throttle joint bolt.  
Remove the locking washer and ball joint seat.  
Disconnect the ball joint of the throttle link from the throttle joint pipe.  
Remove the rod.  
Disconnect the throttle joint pipe from the No. 3 carburetor throttle linkage.  
Note each parts location to insure original assembly.

**NOTE**

For easy removal, hold the joint pipe and turn the throttle link.

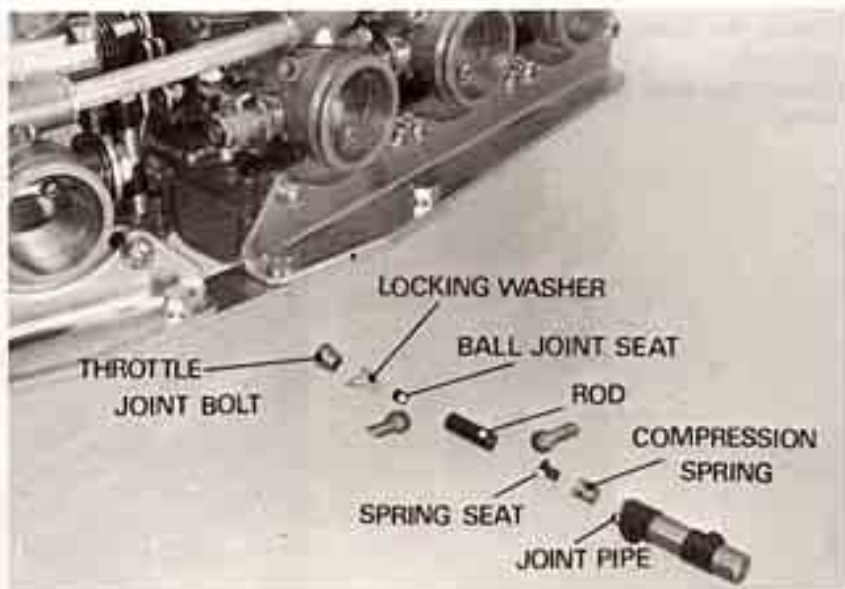





Remove the rear bracket.



Remove the front bracket.

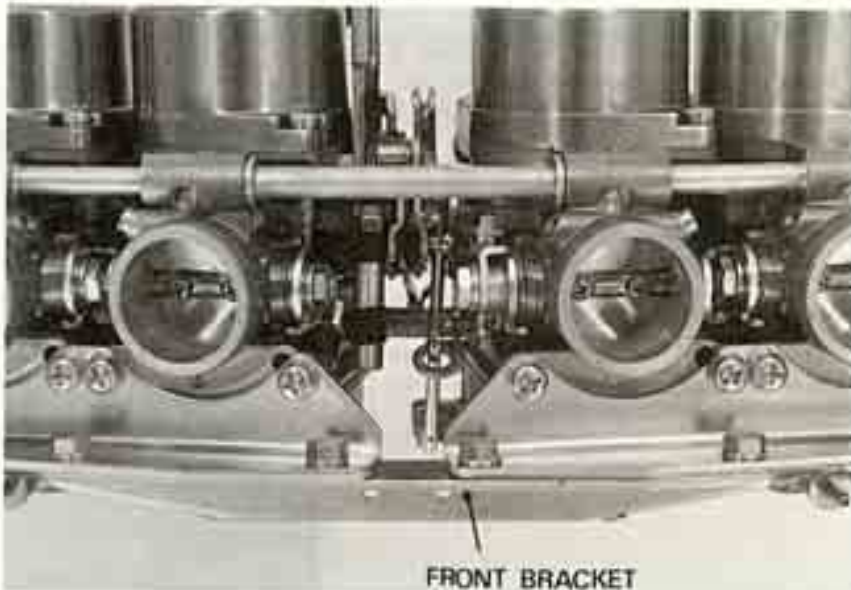

Carefully separate the carburetors.

**CAUTION**

- Separate the carburetor horizontally to prevent damage to the fuel and air joint pipes and choke link. Then, tilt the right carburetor assembly to clear the accelerator pump rod.
- Do not bend the accelerator pump rod.

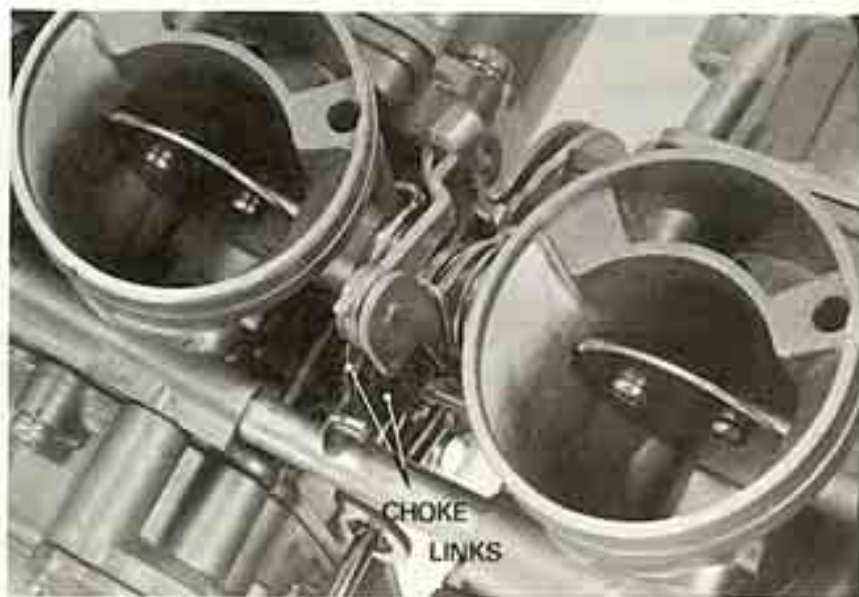



**FUEL SYSTEM**

Blow the air and fuel passages with compressed air.

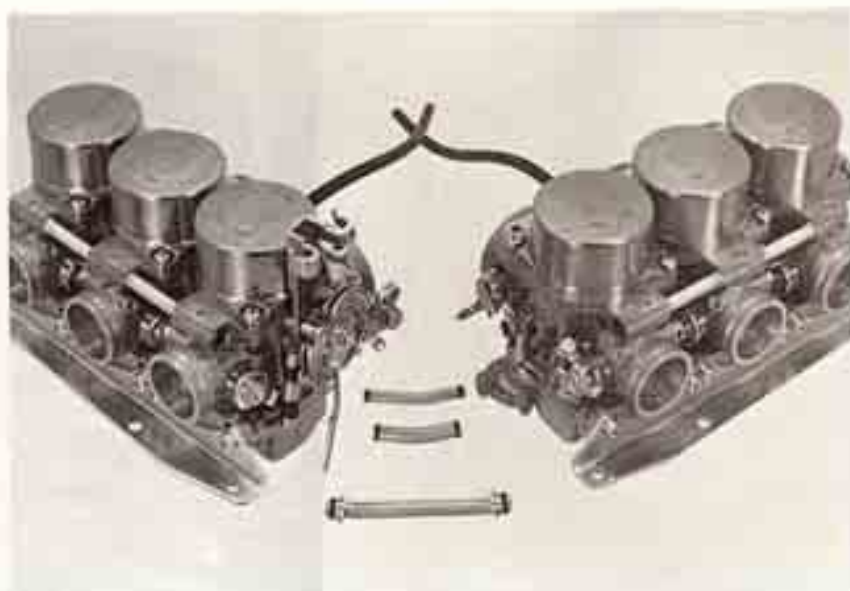

**NOTE**

The separation of the No. 1, 2 and 3 carburetors is given here. The procedure is similar for No. 4, 5 and 6 carburetors.

Loosen the synchronization adjusting screw lock nuts and adjusting screw with the carburetor throttle wrench until there is no tension.

**NOTE**

Turn the synchronization screws in until they seat and note the number of turns to ensure original positioning.



Cut off the staked ends of the choke valve screws.

Remove the choke valves.

**NOTE**

Do not allow filings to enter the carburetors.

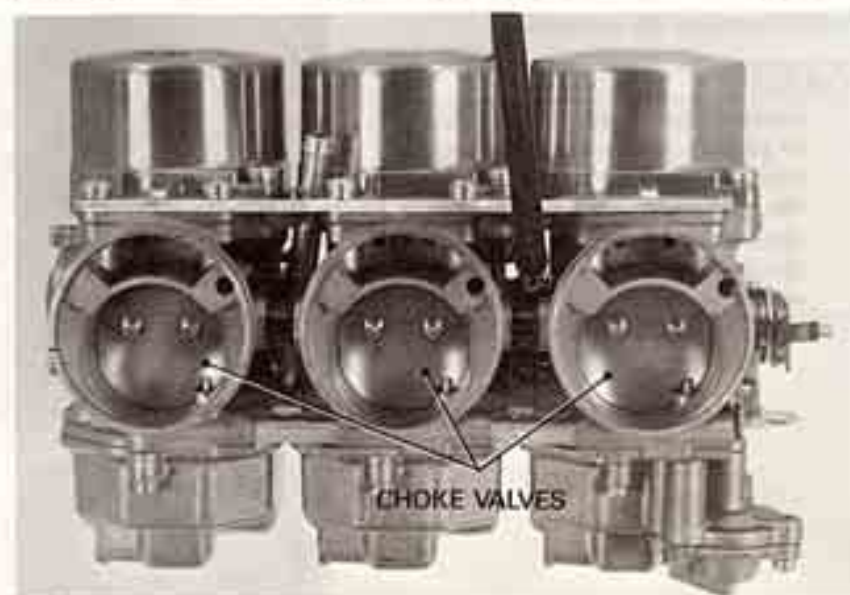





Remove the choke relief spring from the choke link and pull the choke shaft out.

**CAUTION**

*Do not reuse the choke shaft, choke valves and screws.*



Remove the rear and front brackets.



Carefully separate the carburetors.  
Blow the air and fuel joint pipes with compressed air.





## LINKAGE DISASSEMBLY

Remove the right throttle joint, using the same procedure as for the left throttle joint.

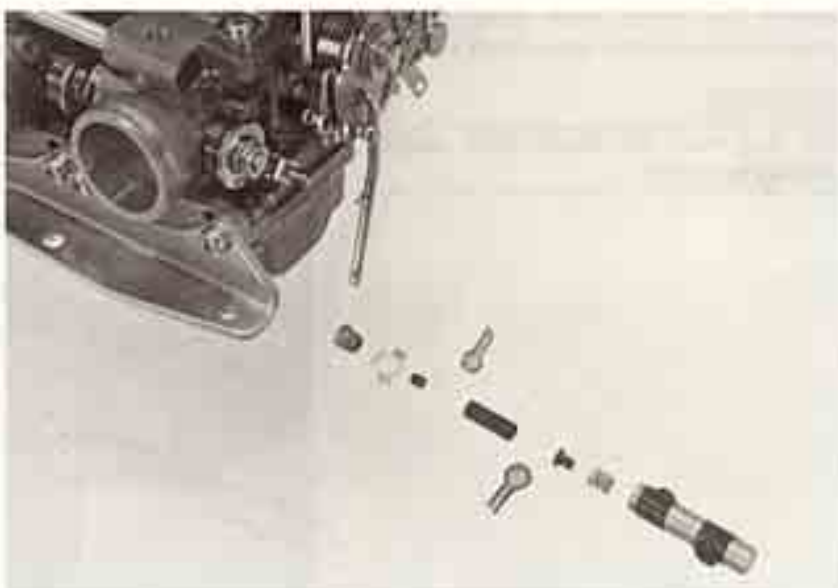

Remove the throttle link bolt.  
Remove the throttle link.



Remove the fast idle adjusting arm cotter pin.  
Remove the fast idle adjusting arm.

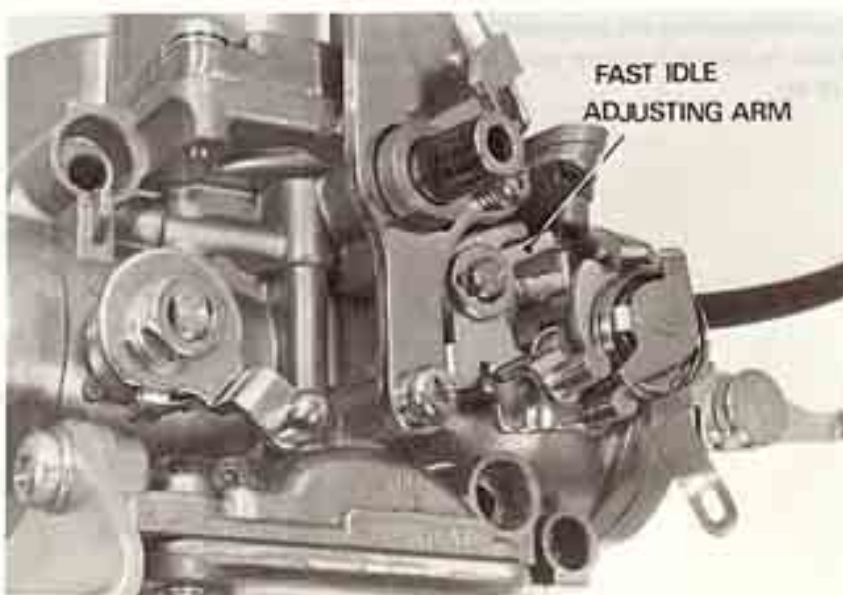





### CARBURETOR ASSEMBLY

#### NOTE

- Assemble one set of three carburetors at a time.
- No. 1, 2 and 3 carburetor assembly is shown here. The procedure is similar for the No. 4, 5 and 6 carburetors.

Install new O-rings on the air and fuel joint pipes securely.

Install the air cutoff valve joint, fuel joint, accelerator pump joint and air vent pipes on the No. 3 carburetor.

Install the choke dust tube.

#### NOTE

- Apply a thin coating of oil to the O-rings.

Loosen the synchronization adjusting screw until there is no tension when assembling new carburetors.

Insert the No. 3 carburetor throttle link between the plain washers slightly.

Assemble the No. 2 and No. 3 carburetors, pressing them together carefully.

#### NOTE

- The large washer should be positioned on the spring side.

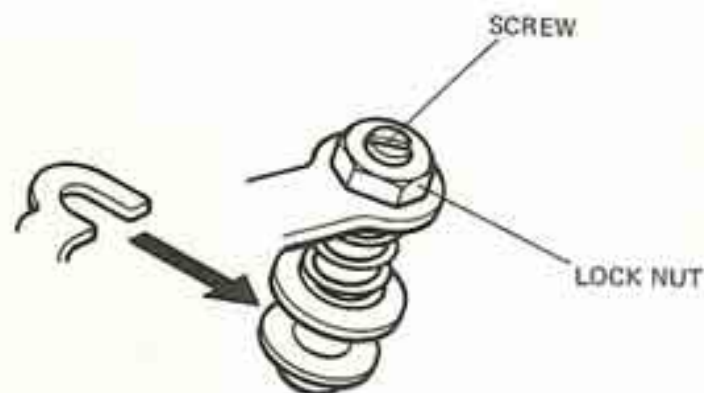

Attach the No. 1 carburetor to the No. 2 carburetor, pressing them together carefully.

#### NOTE

- Check the condition of the O-rings and choke dust tubes.





**FUEL SYSTEM**

Install the front bracket loosely.  
Place the carburetors on a flat surface with the float chamber up.  
Press the carburetors together equally and tighten the screws in the sequence shown in two or more steps to prevent carburetor misalignment.

**TORQUE: 0.4–0.6 kg-m (3–4 ft-lb)**

**NOTE**

Insert the choke shaft to ensure correct carburetor alignment before tightening screws. Check that the choke shaft operation is smooth. If it is not, recheck the carburetor alignment.



Install the rear bracket using the same procedure as for the front bracket.

**TORQUE: 0.28–0.42 kg-m (2–3 ft-lb)**

**NOTE**

No. 3 and No. 4 carburetors require 5 x 18 mm screws. The other carburetors require 5 x 12 mm screws.



**NOTE**

Right carburetor screw tightening sequence is shown here.

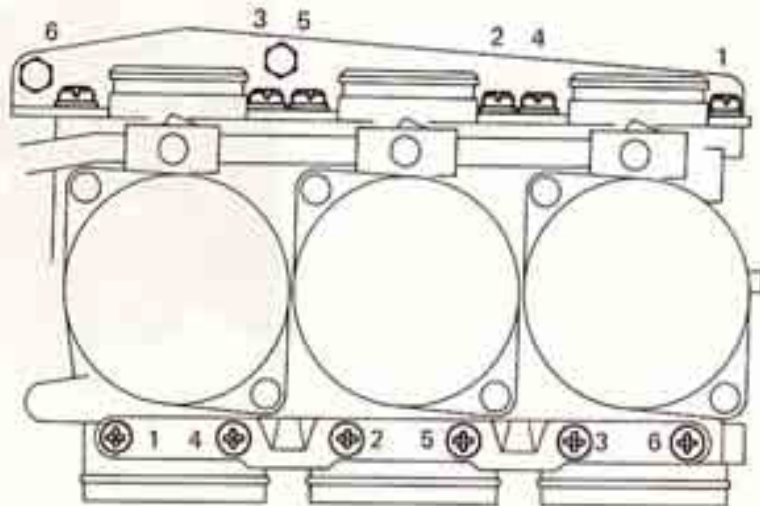





Install the thrust spring between the No. 1 and No. 2 carburetor throttle valve links.



Turn each synchronization adjusting screw to its original position as noted during disassembly.

### NOTE

Make each distance between the by-pass hole in the carburetor body and throttle valve equal when assembling new carburetors.

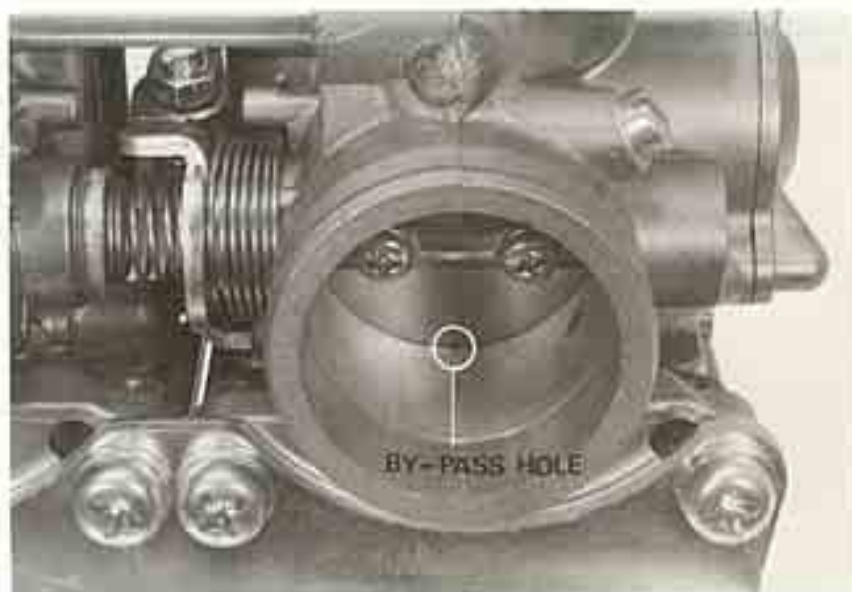

Inspect throttle operation as described below:

- Open the throttle slightly by pressing the No. 3 carburetor ball joint. Then release the throttle.
- Make sure that it returns smoothly.
- Make sure that there is no drag when opening and closing the throttle.

Install a new choke shaft.

Check that choke shaft operation is smooth and it does not bind during installation. If it binds, the carburetors may not be properly aligned or the shaft may be bent.





**FUEL SYSTEM**

Slide the choke relief spring over the choke shaft.

Install the choke shaft.

Install the choke valve, but do not tighten the bolts.

Make sure that the clearance between the choke shaft lever and carburetor body is approximately 1 mm (0.04 in).

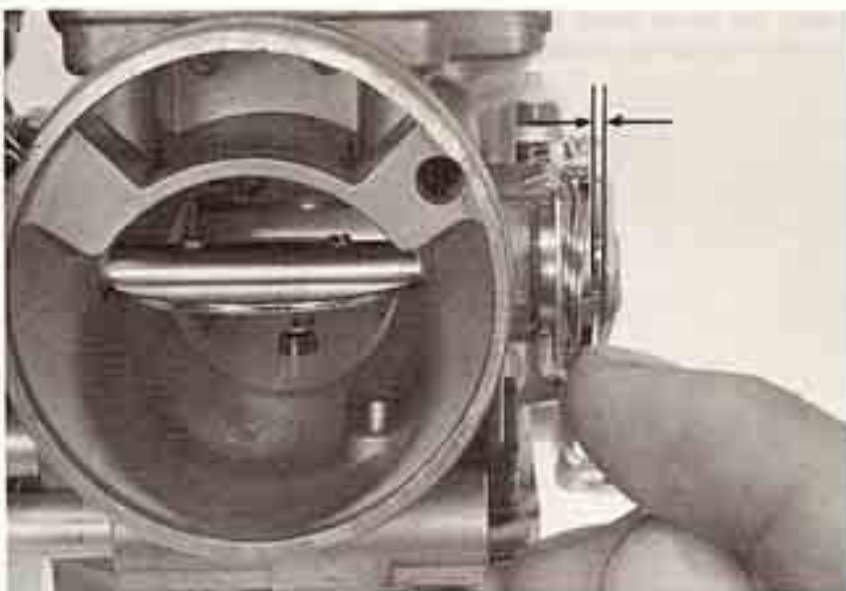

Attach the choke relief spring to the choke link and choke shaft lever.

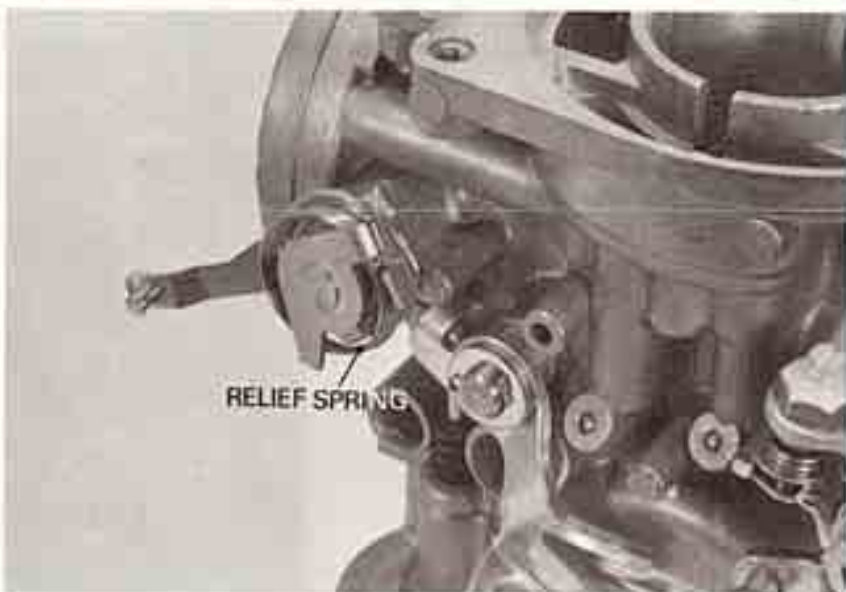

Make sure that choke valve operation is smooth by moving the choke link.

Close the choke valve by turning the choke link.

Hold the choke link.

Press the choke valve end to the fully opened position.

Release the choke valve, then make sure that it returns smoothly.

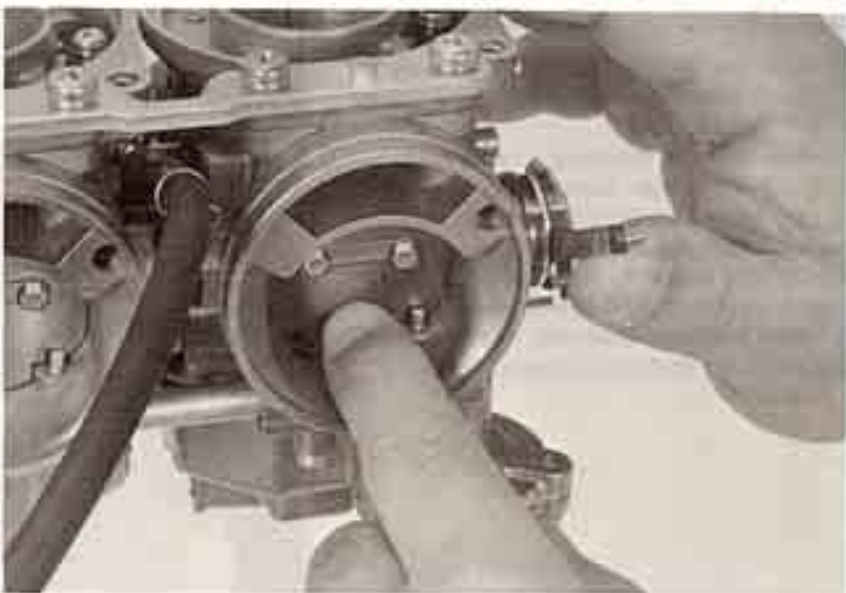





Tighten the choke valve bolts.

**TORQUE:** 0.06–0.12 kg-m  
(5–11 in-lb, 0.4–0.9 ft-lb)

Fold the tabs of the lock washer up.  
Recheck the throttle and choke operation.

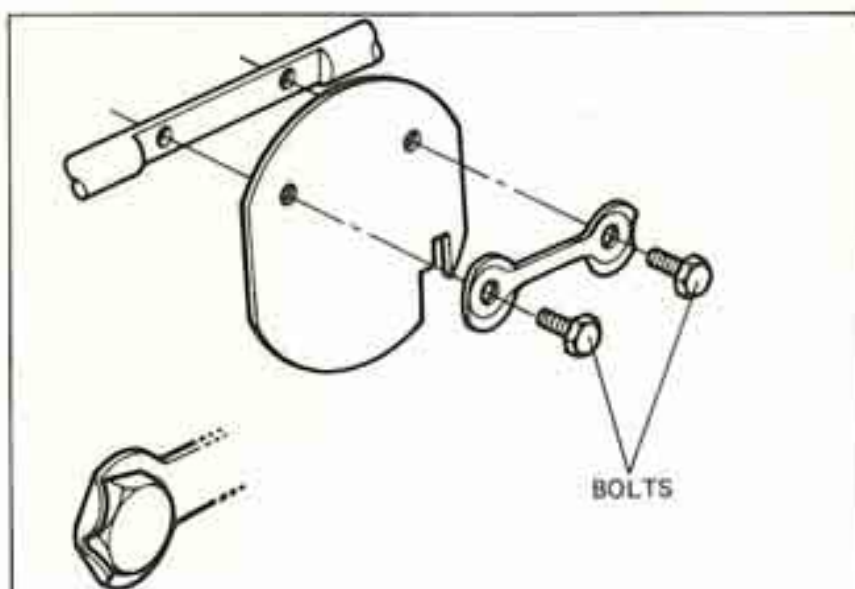

Loosen the No. 3 and No. 4 carburetor rear bracket screws.  
Connect the throttle joint to the throttle link.

### CAUTION

- Do not damage the ball joints and rubber grommets.
- Do not allow dust in the throttle joint pipe.
- Use a new locking washer.

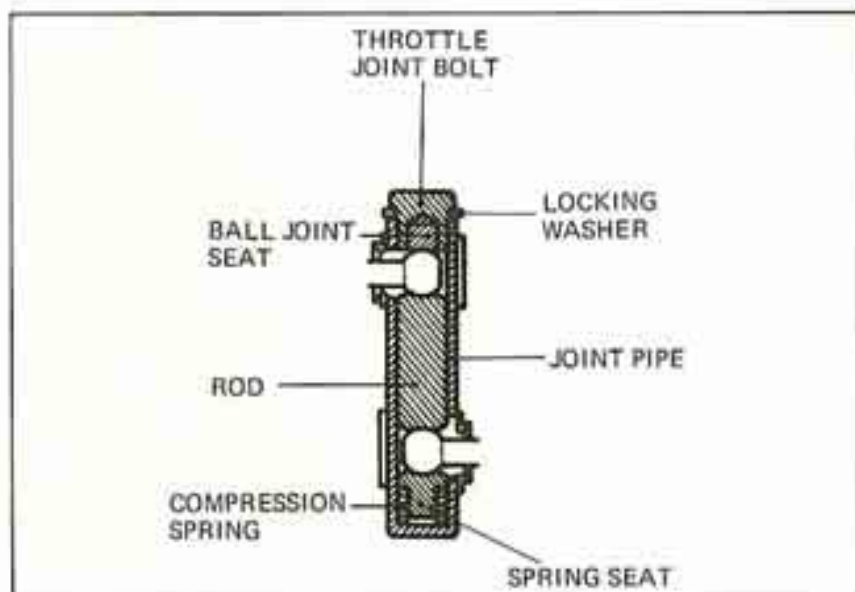

Tighten the throttle joint bolt.

**TORQUE:** 0.28–0.42 kg-m (2–3 ft-lb)

Secure the bolt by bending the tabs of the locking washer.

### NOTE

- Bend the two small tabs up against the bolt head.
- Bend the center tab over the throttle joint flat.





**FUEL SYSTEM**

**FAST IDLE ADJUSTMENT**

**FAST IDLE:** 2000 ± 500 rpm (after break-in)

Close the throttle valve and open the choke valve.

Measure the clearance between the throttle link and fast idle adjusting arm pin.

**SPECIFIED CLEARANCE:**

0.7–1.0 mm (0.03–0.04 in)

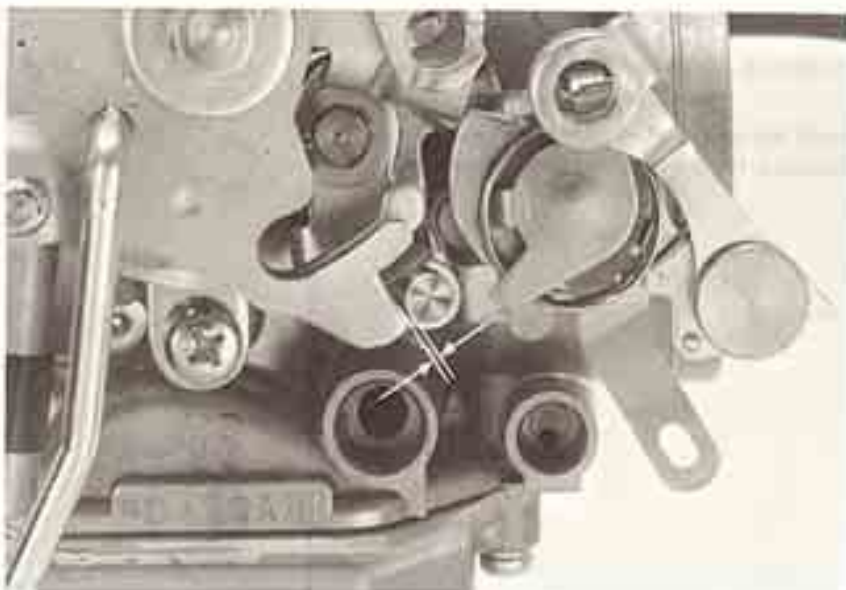

Adjust by opening and closing the fork end of the fast idle adjusting arm.



**INSTALLATION**

Install new O-rings on the air and fuel joint pipes.

Install the air cutoff valve joint pipe, fuel joint pipe and accelerator pump joint pipe on the No. 4 carburetor.

**NOTE**

- Apply a thin coating of oil to the O-rings.
- Install the accelerator pump joint pipe with the mark toward the No. 4 carburetor.

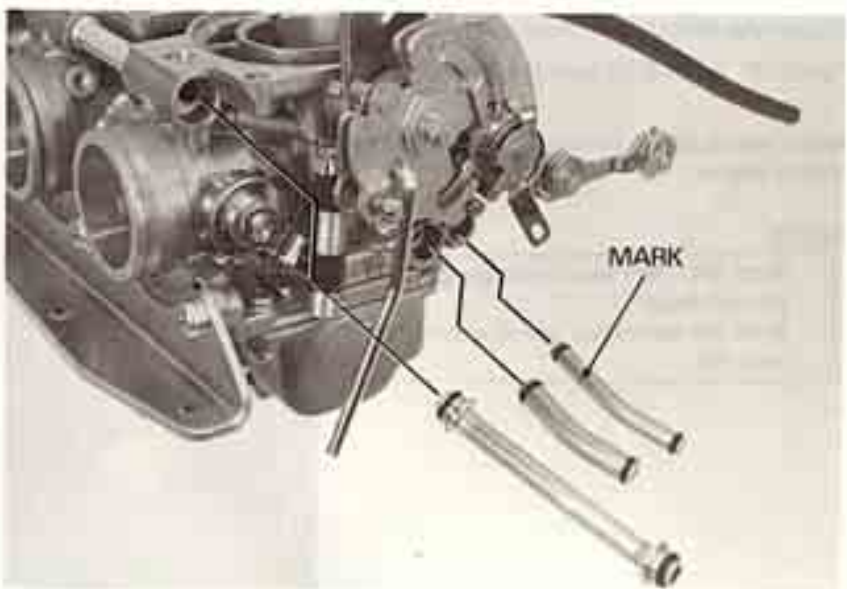





Insert the accelerator pump rod.  
Position the right and left carburetor assemblies properly, aligning the pipes and choke link.

Press the assemblies together carefully.



Install the front and rear brackets loosely.



Connect the other throttle joint to the throttle link.

Tighten the throttle joint bolt.

Secure the bolt by bending the tabs of the locking washer as for the previous throttle joint.

**TORQUE: 0.28–0.42 kg-m (2–3 ft-lb)**





**FUEL SYSTEM**

Tighten the front and rear brackets in the sequence shown.

**TORQUE: 0.28–0.42 kg-m (2–3 ft-lb)**

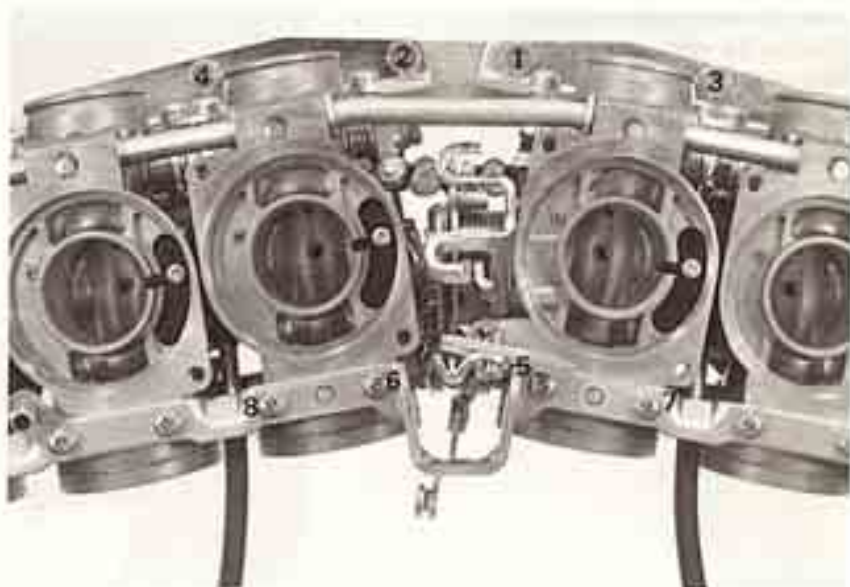

Turn the synchronization adjusting screw on the No. 3 carburetor so that all throttle valve positions are equal.

Move the throttle link to check throttle operation.

Move the choke link to check choke operation and synchronization.



Install the accelerator pump rod spring, washer, collar and cotter pin.

Install the throttle stop screw.

Install the vacuum cylinder components.

Install the overflow tubes.







SPRING INSTALLATION

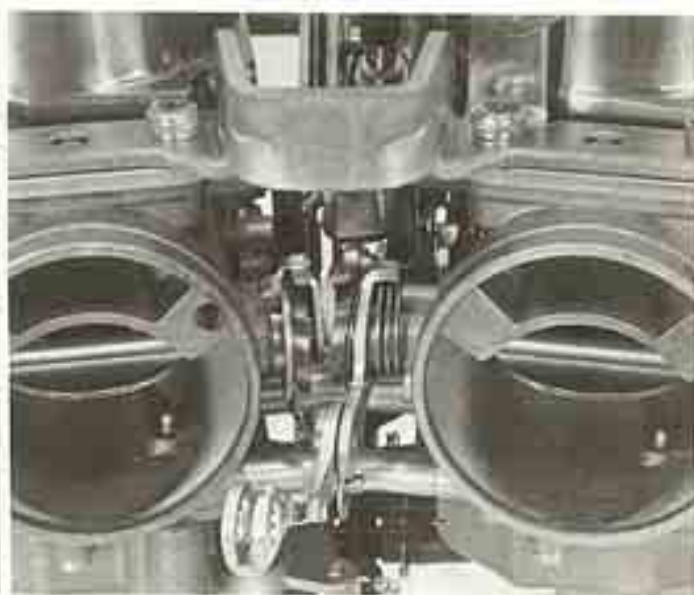
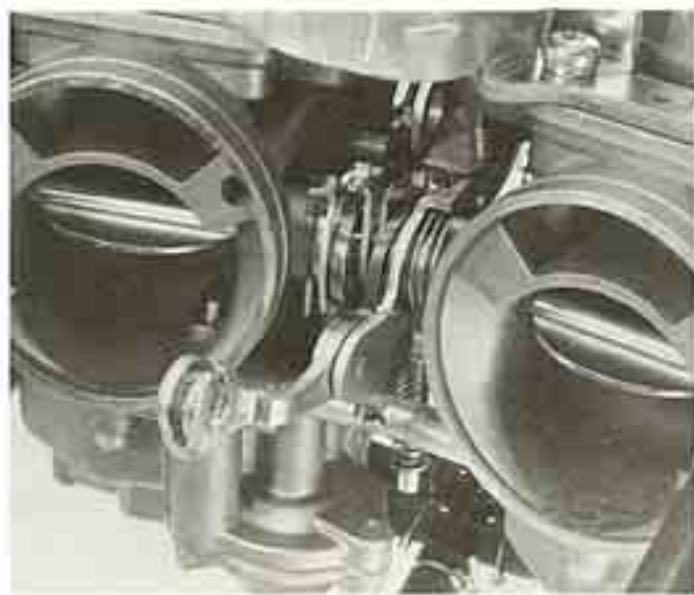
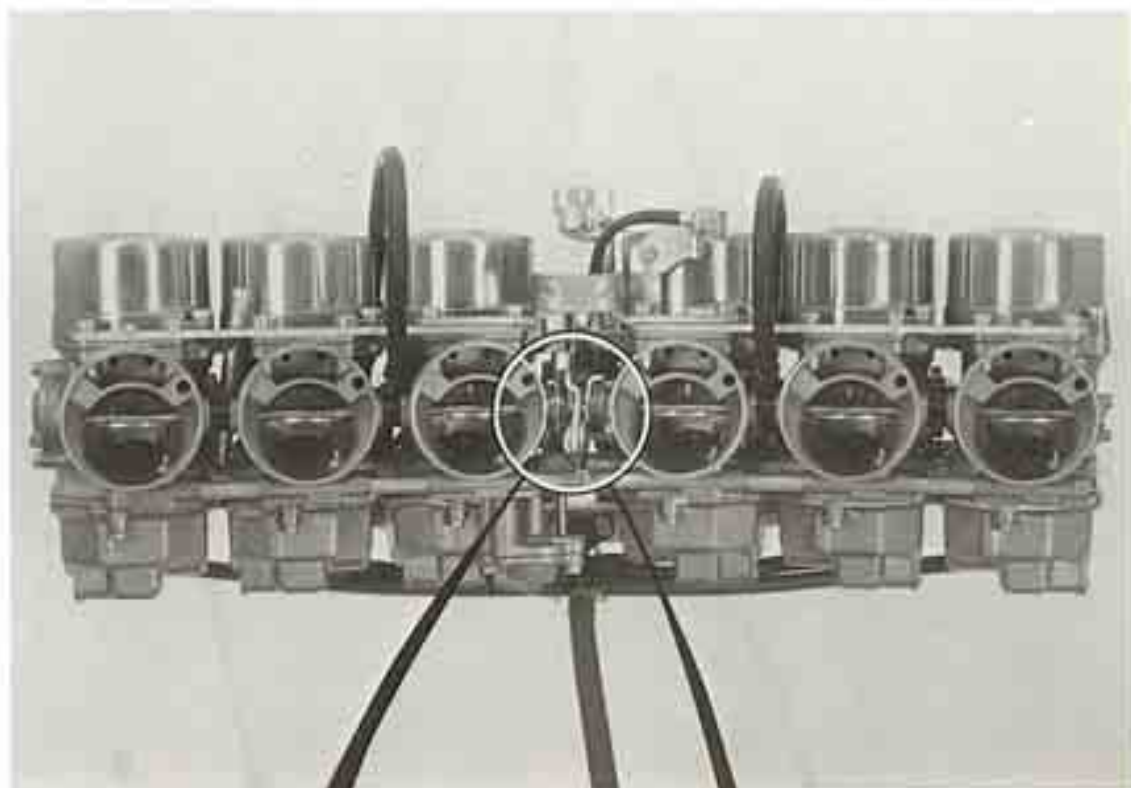

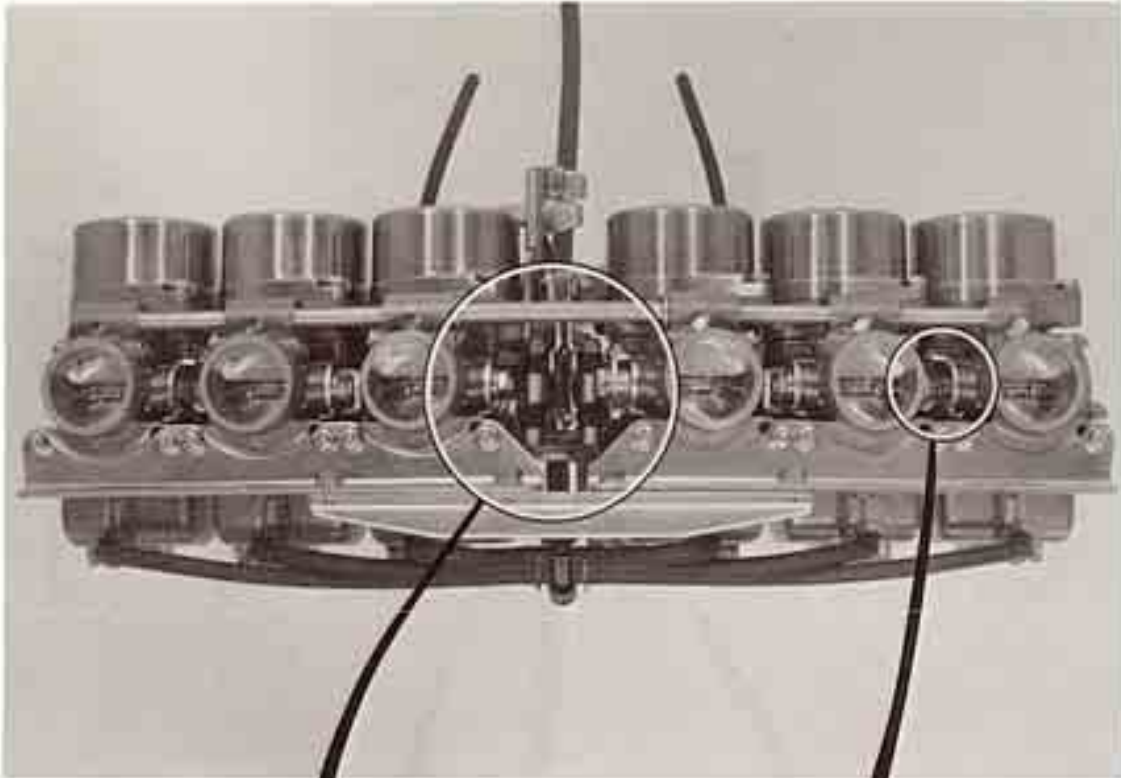





TUBE ROUTING

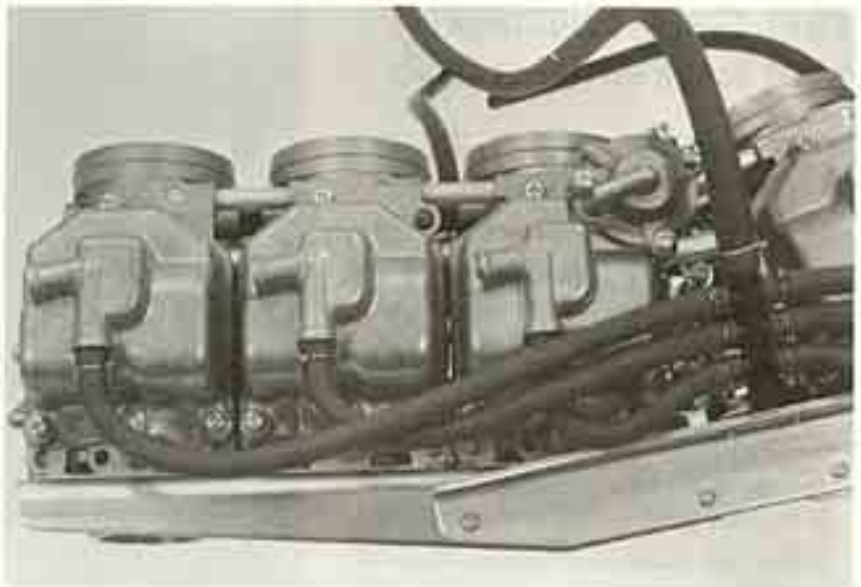

**ACCELERATOR PUMP ADJUSTMENT**

Measure the clearance between the accelerator pump rod and adjusting arm with the throttle valve closed.

**SPECIFIED CLEARANCE:**  
0–0.04 mm (0–0.0016 in)

Adjust by bending the adjusting arm.

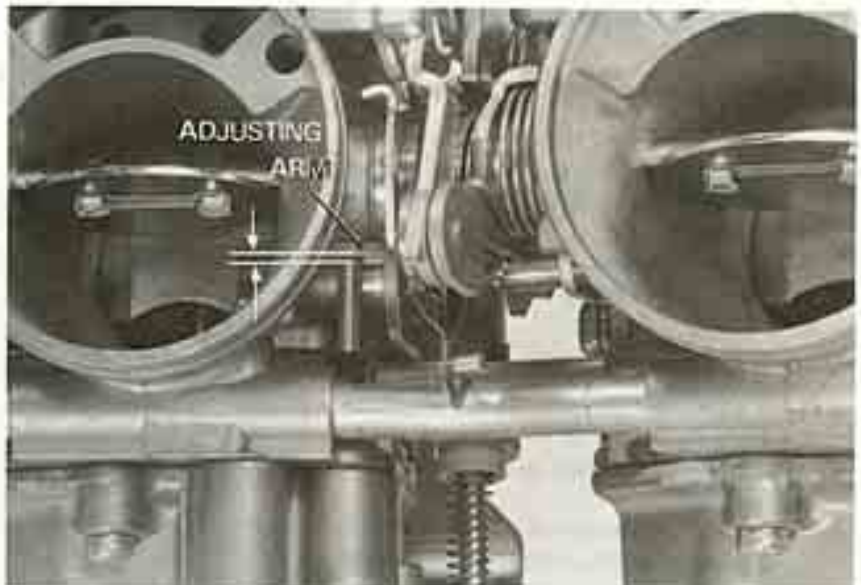

Measure the clearance between the adjusting arm and stopper on the carburetor body.

**SPECIFIED CLEARANCE:**  
3.1–3.3 mm (0.12–0.13 in)

Adjust by bending the adjusting arm.





## PILOT SCREW ADJUSTMENT

### PILOT SCREW INITIAL SETTING

#### NOTE

The pilot screw is factory pre-set and no adjustment is necessary unless the carburetor is overhauled.

Turn the pilot screw clockwise until it seats lightly and back it out to the specification. This is a preliminary setting prior to the final pilot screw adjustment.

#### PILOT SCREW OPENING: 1-1/4

#### CAUTION

Damage to the pilot screw seat will occur if the pilot screw is tightened against the seat.

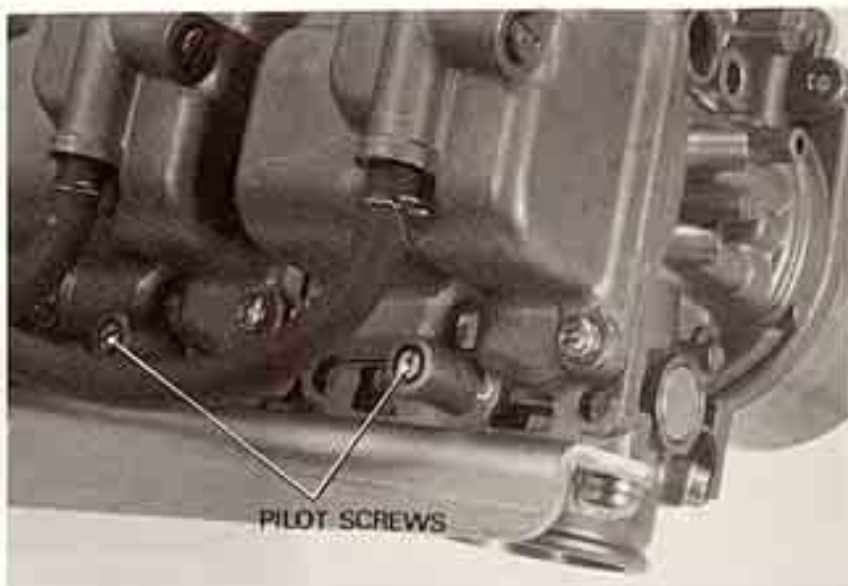

### PILOT SCREW ADJUSTMENT

#### NOTE

Use a tachometer with graduations of 50 rpm.

1. Warm up the engine to operating temperature. Stop and go driving for 10 minutes is sufficient.
2. Attach a tachometer.
3. Adjust the idle speed with the throttle stop screw.

#### IDLE SPEED: 900 ± 100 rpm

4. Turn each pilot screw in or out to obtain the highest engine rpm.
5. Adjust the idle speed with the throttle stop screw.
6. Turn the No. 1 carburetor pilot screw in until it seats lightly, recording the number of turns.
7. Turn the No. 2 carburetor pilot screw in until the engine speed drops 50 rpm.
8. Turn the No. 2 carburetor pilot screw 1/2 turn out from the position obtained in Step 7.
9. Perform Steps 7 and 8 for the No. 3, 4, 5 and 6 carburetor pilot screws.
10. Turn the No. 1 pilot screw out to its original opening.
11. Turn the No. 6 pilot screw in until it seats lightly, recording the number of turns.
12. Perform Steps 7 and 8 for the No. 5, 4, 3, 2 and 1 carburetor pilot screws.
13. Turn the No. 6 pilot screw out to its original opening.
14. Adjust the idle speed with the throttle stop screw.







### FUEL TANK

**WARNING**

*Do not allow flames or sparks near gasoline. Wipe up spilled gasoline at once.*

Check the vent hole of the filler cap for blockage.

Check that fuel is flowing out of the fuel valve freely.

If the fuel flow is restricted, clean the fuel strainer.

**NOTE**

Do not overtighten the fuel valve lock nut.

Make sure there are no fuel leaks.

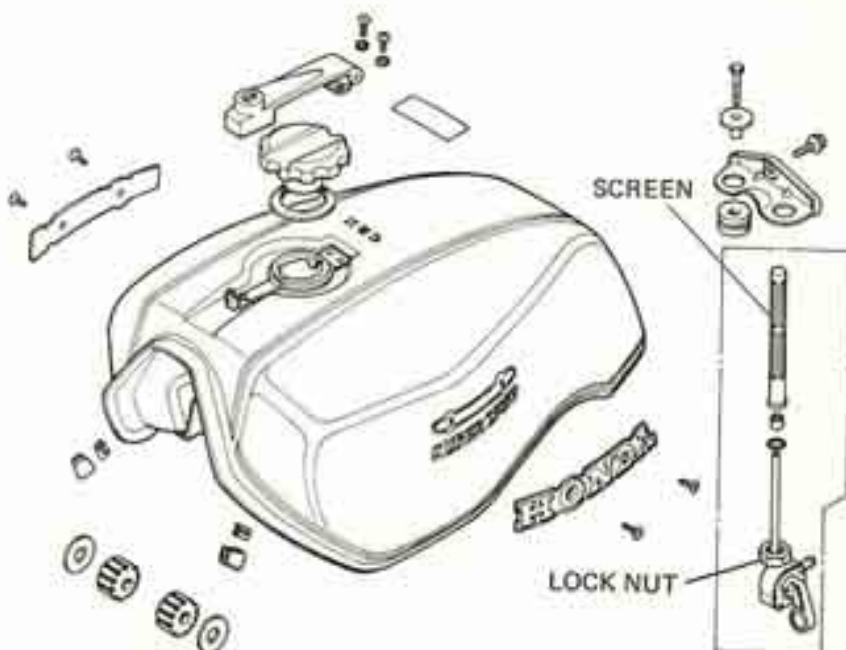

### AIR CLEANER CASE

#### AIR CLEANER CASE/CHAMBER

Check the air cleaner case and chamber for cracking or deterioration.

#### CRANKCASE VENTILATION SYSTEM

Check that the breather tube is not restricted.

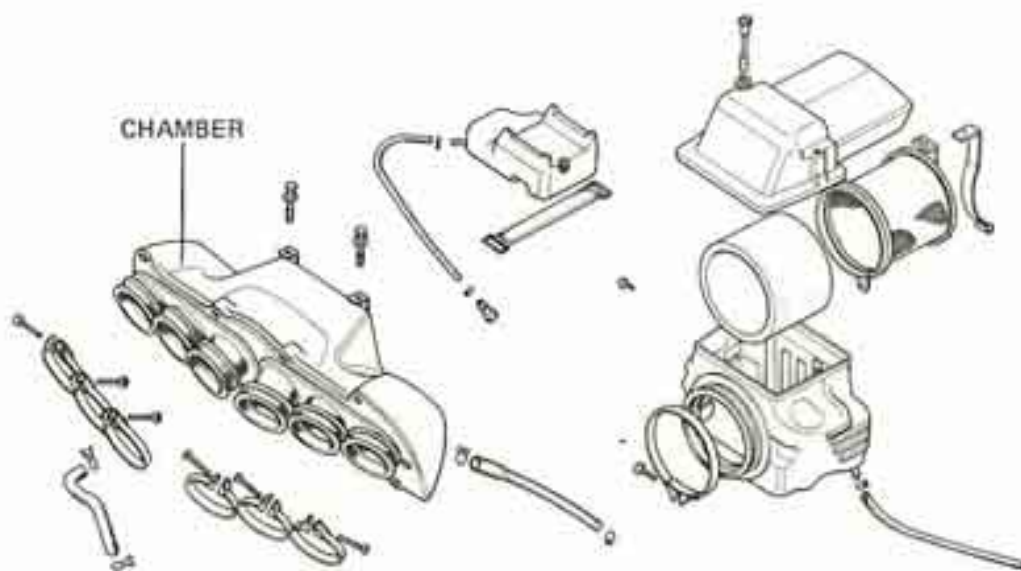

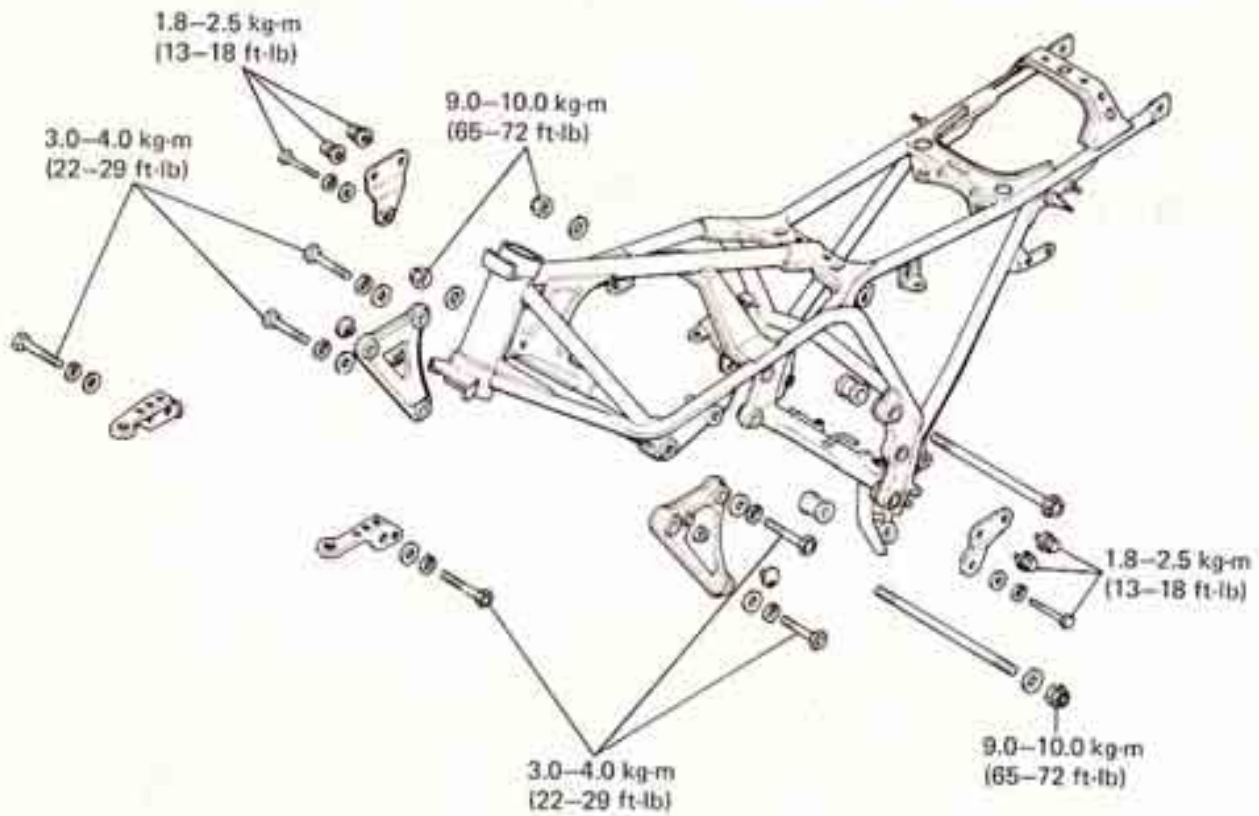





SERVICE INFORMATION	5-1
TILTING ENGINE	5-2
ENGINE REMOVAL	5-5
ENGINE INSTALLATION	5-6

## SERVICE INFORMATION

### WORKING PRACTICE

- The following parts or components can be serviced with the engine installed in the frame:

- Clutch
- Shift linkage
- Camshaft
- A. C. generator
- Starter motor

- The following parts or components can be serviced with the engine tilted forward in the frame:

#### NOTE

The engine can be pivoted on the rear lower hanger bolt after removing the three hanger bolts.

- Carburetor
- Cylinder
- Cylinder head
- Piston

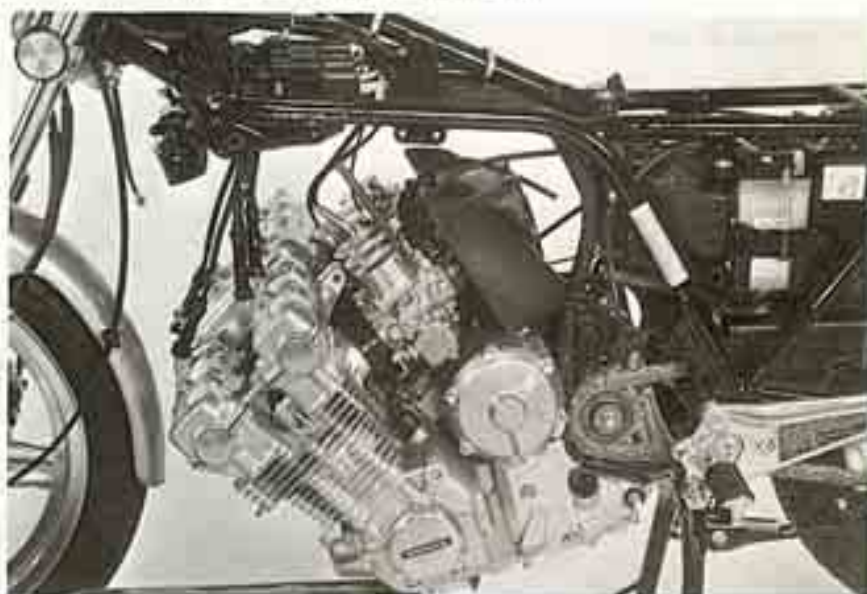

### SPECIFICATIONS

Engine dry weight	106 kg (234 lb) approx.
Oil capacity	5.5 lit (5.8 US qt) at engine assembly 5.0 lit (5.3 US qt) at change

### TORQUE VALUES

8 mm bolt	1.8-2.5 kg-m	(13-18 ft-lb)
10 mm bolt	3.0-4.0 kg-m	(22-29 ft-lb)
14 mm bolt	9.0-10.0 kg-m	(65-72 ft-lb)
Rear axle nut	8.0-10.0 kg-m	(58-72 ft-lb)
Drive sprocket	3.3-3.8 kg-m	(24-27 ft-lb)
Spark plug	1.2-1.6 kg-m	(9.0-12 ft-lb)



## TILTING ENGINE

Remove the seat nuts.  
 Pull back on the seat levers and remove the seat.



Remove the air cleaner cover and fuel tank.  
 Remove the air cleaner.

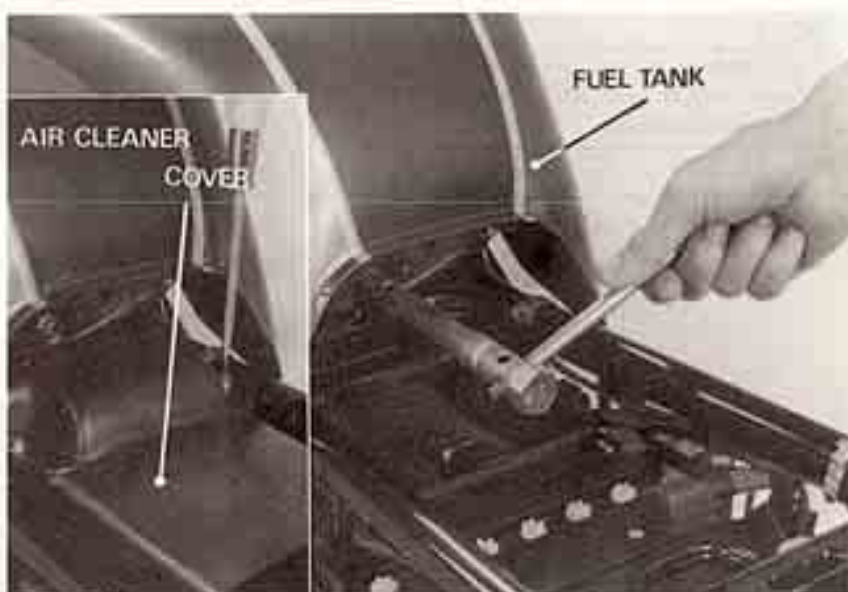

Remove the exhaust system.  
 Remove the right and left side covers.







Remove the tachometer cable from the cylinder head cover.  
Remove all spark plug caps, and remove the No. 1 and No. 6 spark plugs.

**NOTE**

Do not allow screws and nuts to fall into the cylinders through the spark plug holes.

**SPARK PLUG****TACHOMETER CABLE**

Remove the choke cable from the choke lever.  
Remove the throttle cable from the right handlebar switch.  
Loosen the rear axle nut and drive chain adjusting bolts. Push the rear wheel forward.



Remove the clutch cable at the clutch arm.  
Place a jack under the engine.  
Remove the right and left engine hanger brackets and plates.  
Loosen the screw securing the air cleaner-to-air funnel connecting tube band.

**SCREW****CLUTCH CABLE**



Remove the two bolts holding the air funnel.  
 Disconnect three couplers.

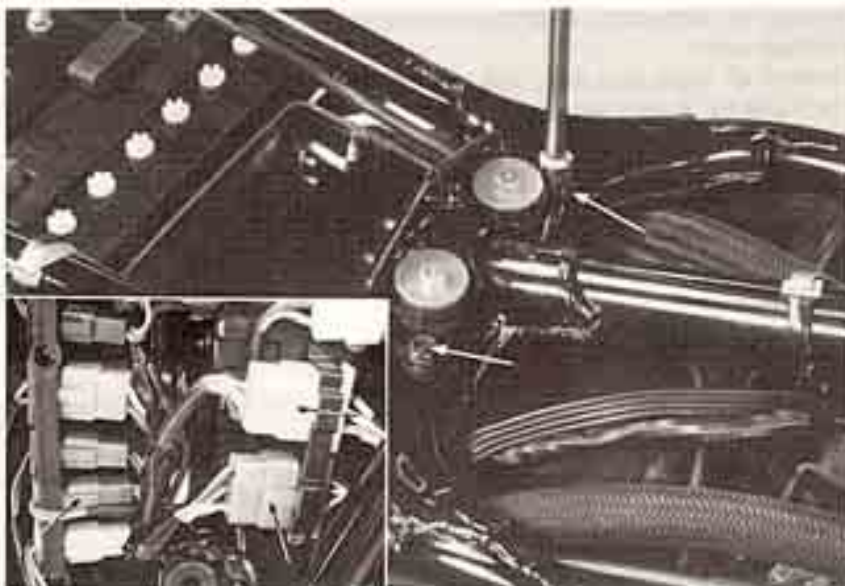

Remove the upper engine hanger bolt.  
 Remove the gear change pedal.

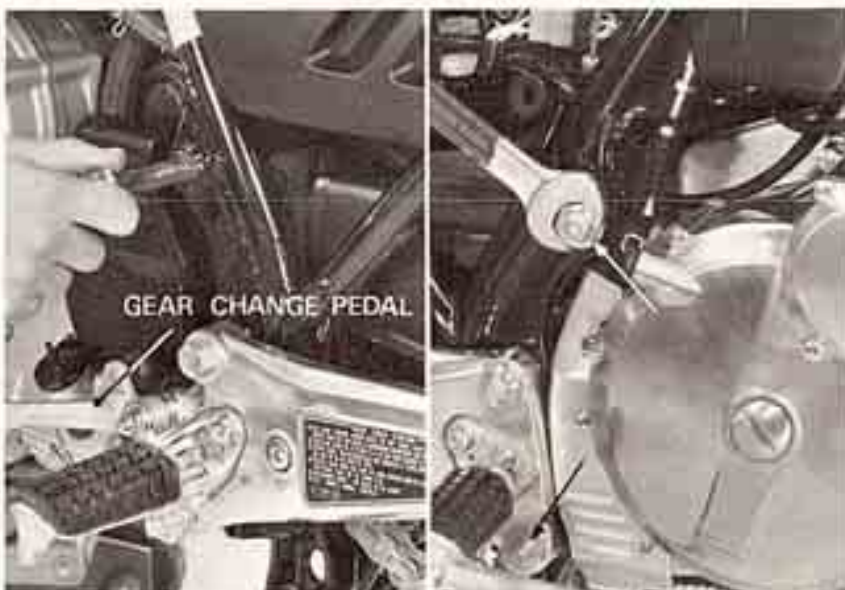

Remove the drive sprocket cover.  
 Disconnect the battery negative terminal at  
 the starter motor.  
 Disconnect the tube.

Tilt the engine forward on the lower rear  
 hanger bolt by lowering the jack.







## ENGINE REMOVAL

Drain oil from the engine.  
Perform tilting engine procedures (page 5-2).  
Disconnect the wires from the starter magnetic switch.



Remove the right oil hose cover and remove the oil hose.  
Remove the brake pedal.



Remove the left oil hose cover and remove the oil hose.

Remove the drive sprocket.  
Remove the rear engine mounting bolt.  
Lower the jack and remove the engine.



### NOTE

Jack height must be continuously adjusted during engine removal and installation to prevent damage to mounting bolt threads, wire harnesses and cables.



## ENGINE INSTALLATION

The installation sequence is essentially the reverse of removal.

### NOTE

- Do not damage parts during installation.
- Route the wires and cables properly (Page 1-8).
- Fill the crankcase to the proper level (Page 2-1).
- Perform the following inspection and adjustments:  
Throttle cable free play (Page 3-19).  
Clutch lever free play (Page 3-6).  
Drive chain tension (Page 3-15).  
Choke cable free play (Page 3-9).

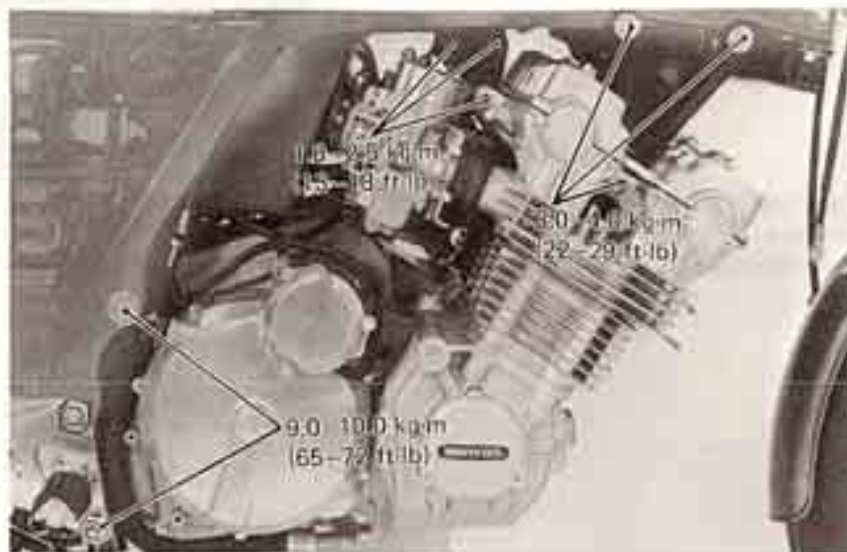

8 mm bolt 1.8– 2.5 kg·m (13–18 ft·lb)  
10 mm bolt 3.0– 4.0 kg·m (22–29 ft·lb)  
14 mm bolt 9.0–10.0 kg·m (65–72 ft·lb)



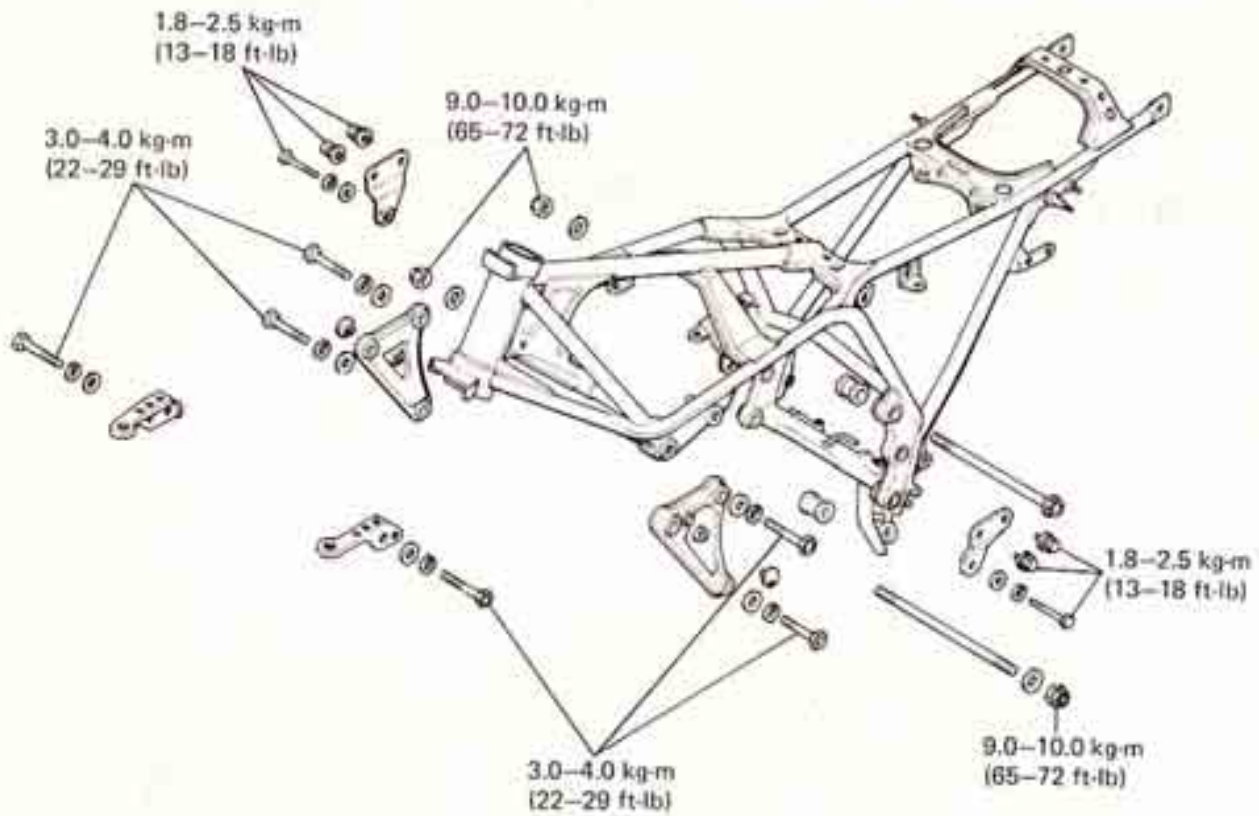



SERVICE INFORMATION	5-1
TILTING ENGINE	5-2
ENGINE REMOVAL	5-5
ENGINE INSTALLATION	5-6

## SERVICE INFORMATION

### WORKING PRACTICE

- The following parts or components can be serviced with the engine installed in the frame:

- Clutch
- Shift linkage
- Camshaft
- A. C. generator
- Starter motor

- The following parts or components can be serviced with the engine tilted forward in the frame:

#### NOTE

The engine can be pivoted on the rear lower hanger bolt after removing the three hanger bolts.

- Carburetor
- Cylinder
- Cylinder head
- Piston

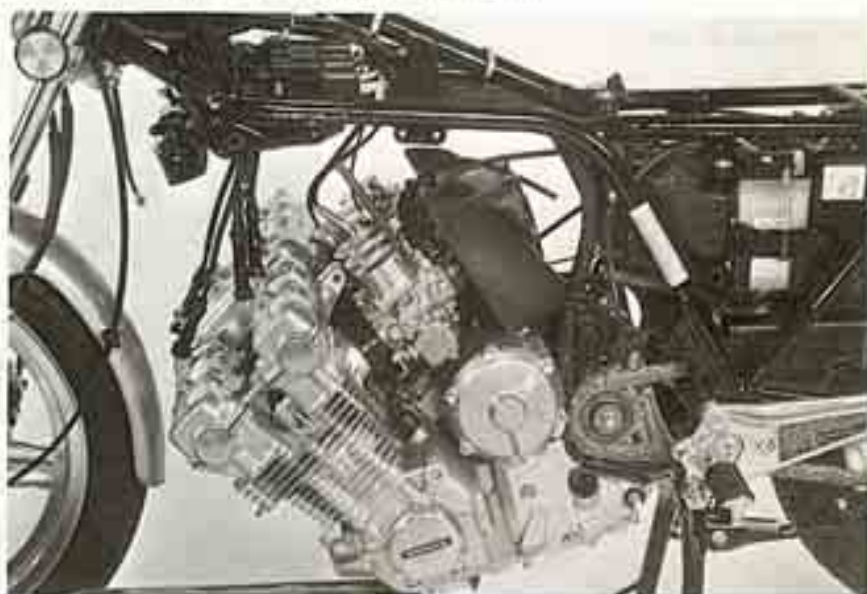

### SPECIFICATIONS

Engine dry weight	106 kg (234 lb) approx.
Oil capacity	5.5 lit (5.8 US qt) at engine assembly 5.0 lit (5.3 US qt) at change

### TORQUE VALUES

8 mm bolt	1.8-2.5 kg-m	(13-18 ft-lb)
10 mm bolt	3.0-4.0 kg-m	(22-29 ft-lb)
14 mm bolt	9.0-10.0 kg-m	(65-72 ft-lb)
Rear axle nut	8.0-10.0 kg-m	(58-72 ft-lb)
Drive sprocket	3.3-3.8 kg-m	(24-27 ft-lb)
Spark plug	1.2-1.6 kg-m	(9.0-12 ft-lb)





## TILTING ENGINE

Remove the seat nuts.  
Pull back on the seat levers and remove the seat.



Remove the air cleaner cover and fuel tank.  
Remove the air cleaner.

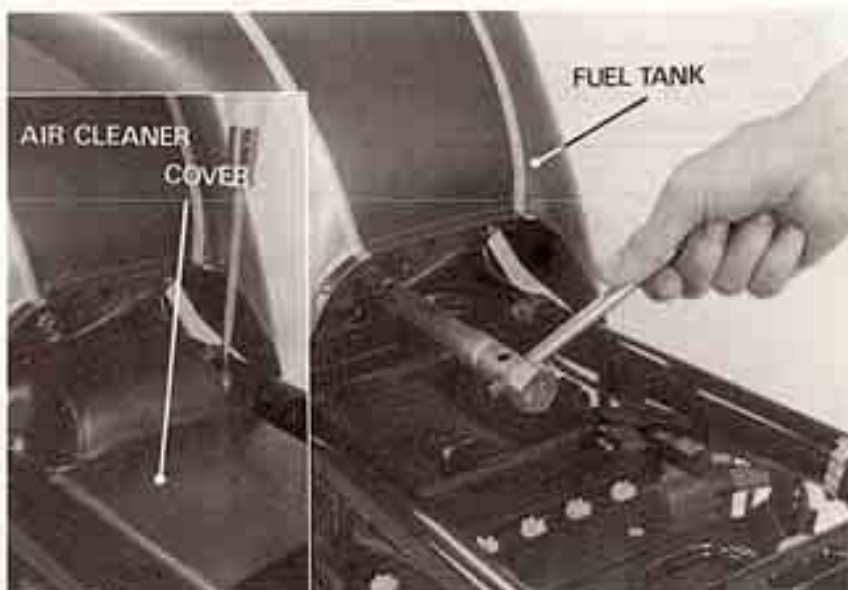

Remove the exhaust system.  
Remove the right and left side covers.





Remove the tachometer cable from the cylinder head cover.

Remove all spark plug caps, and remove the No. 1 and No. 6 spark plugs.

### NOTE

Do not allow screws and nuts to fall into the cylinders through the spark plug holes.

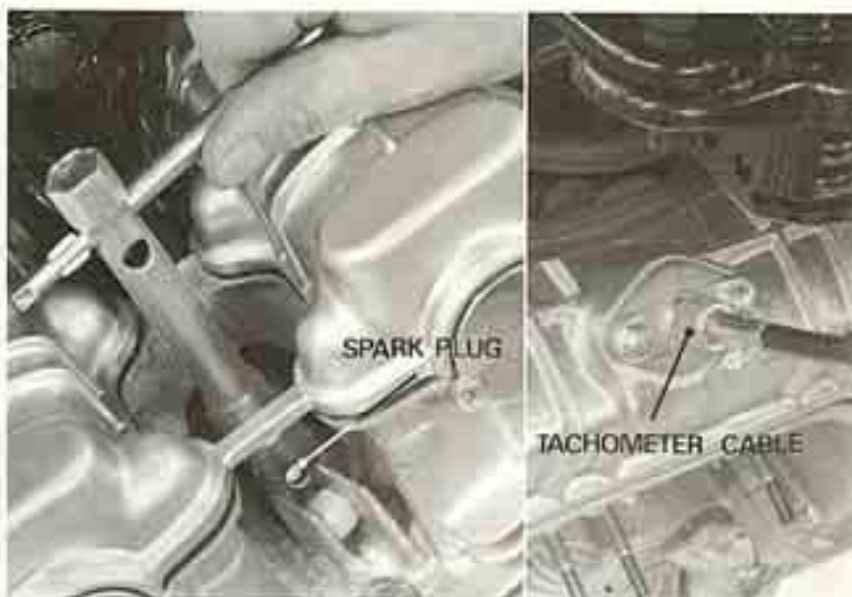

Remove the choke cable from the choke lever.

Remove the throttle cable from the right handlebar switch.

Loosen the rear axle nut and drive chain adjusting bolts. Push the rear wheel forward.



Remove the clutch cable at the clutch arm.

Place a jack under the engine.

Remove the right and left engine hanger brackets and plates.

Loosen the screw securing the air cleaner-to-air funnel connecting tube band.







Remove the two bolts holding the air funnel.  
 Disconnect three couplers.

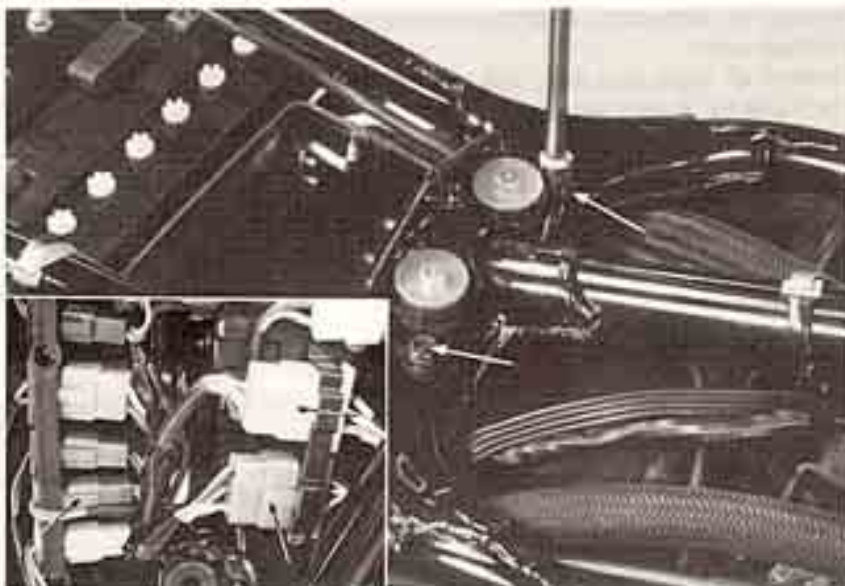

Remove the upper engine hanger bolt.  
 Remove the gear change pedal.

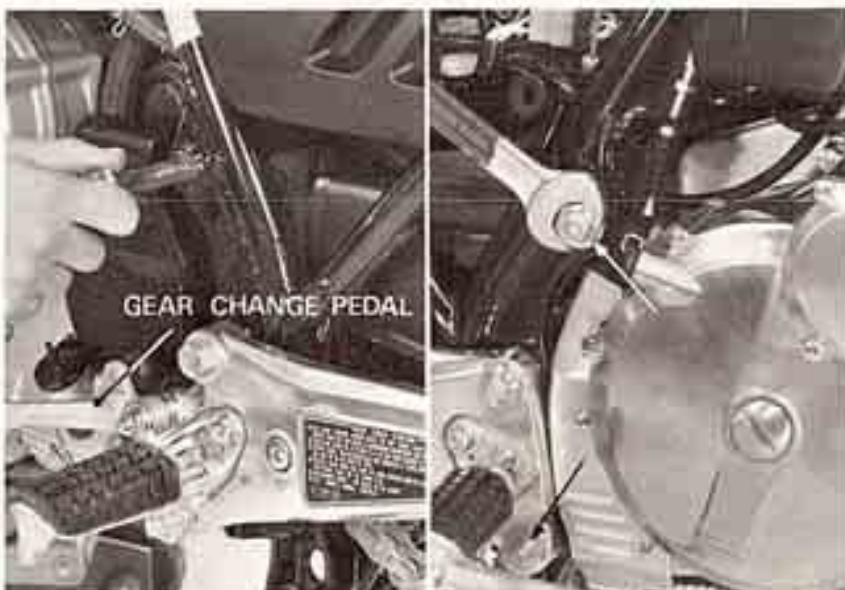

Remove the drive sprocket cover.  
 Disconnect the battery negative terminal at  
 the starter motor.  
 Disconnect the tube.

Tilt the engine forward on the lower rear  
 hanger bolt by lowering the jack.





## ENGINE REMOVAL

Drain oil from the engine.  
Perform tilting engine procedures (page 5-2).  
Disconnect the wires from the starter magnetic switch.

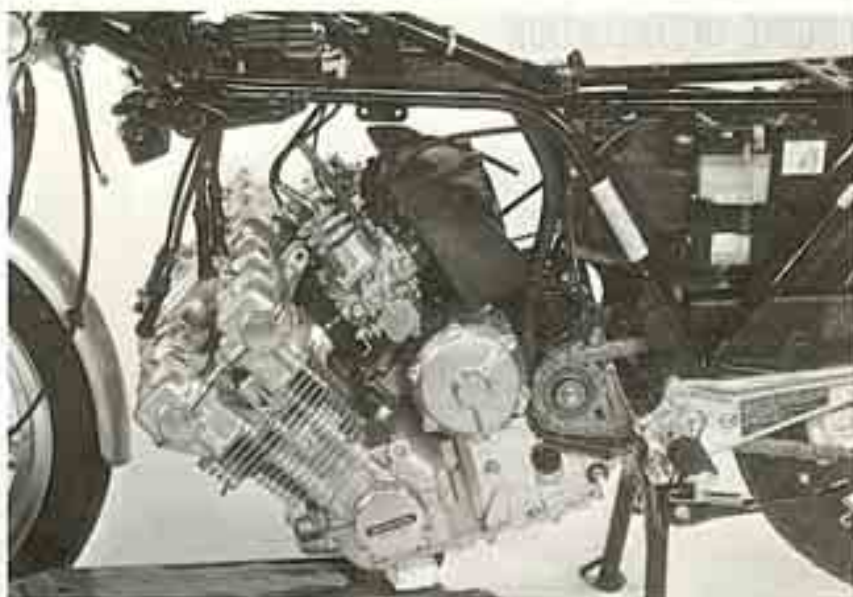

Remove the right oil hose cover and remove the oil hose.  
Remove the brake pedal.



Remove the left oil hose cover and remove the oil hose.

Remove the drive sprocket.  
Remove the rear engine mounting bolt.  
Lower the jack and remove the engine.



### NOTE

Jack height must be continuously adjusted during engine removal and installation to prevent damage to mounting bolt threads, wire harnesses and cables.





## ENGINE INSTALLATION

The installation sequence is essentially the reverse of removal.

### NOTE

- Do not damage parts during installation.
- Route the wires and cables properly (Page 1-8).
- Fill the crankcase to the proper level (Page 2-1).
- Perform the following inspection and adjustments:  
 Throttle cable free play (Page 3-19).  
 Clutch lever free play (Page 3-6).  
 Drive chain tension (Page 3-15).  
 Choke cable free play (Page 3-9).

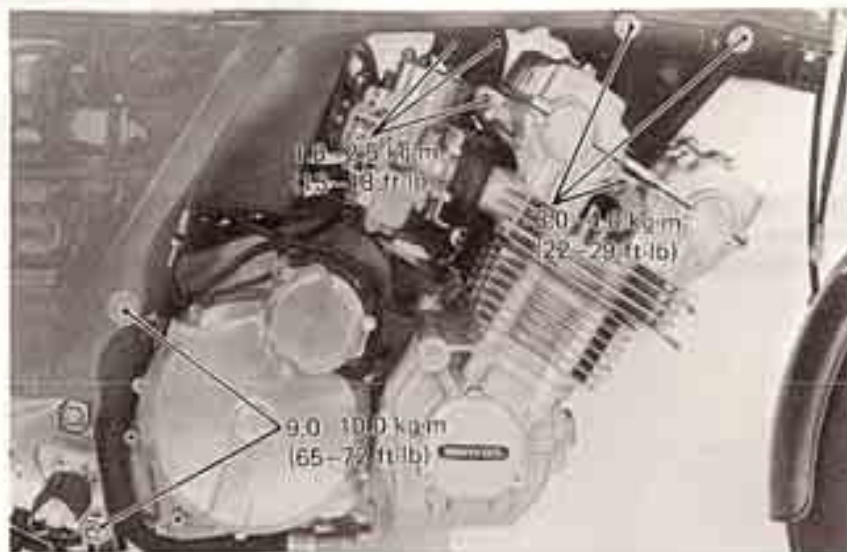

8 mm bolt 1.8- 2.5 kg·m (13-18 ft·lb)  
 10 mm bolt 3.0- 4.0 kg·m (22-29 ft·lb)  
 14 mm bolt 9.0-10.0 kg·m (65-72 ft·lb)



SERVICE INFORMATION	6-1	VALVE GUIDE REPLACEMENT	6-15
TROUBLESHOOTING	6-2	VALVE SEAT INSPECTION/REFACING	6-16
CAMSHAFT REMOVAL	6-3	CYLINDER HEAD ASSEMBLY	6-18
CYLINDER HEAD REMOVAL	6-10	CYLINDER HEAD INSTALLATION	6-19
CYLINDER HEAD DISASSEMBLY	6-11	CAMSHAFT INSTALLATION	6-21

## SERVICE INFORMATION

### WORKING PRACTICE

All cylinder head maintenance and inspection can be accomplished with the engine installed.

Camshaft lubricating oil is fed through the oil hose. Be sure the holes in the oil hose bolt are not clogged.

During assembly, apply molybdenum disulfide to the camshaft bearings to provide initial lubrication. Pour clean engine oil into the oil pockets in the cylinder head to lubricate the camshafts.

To remove the cylinder head, the engine should be tilted. The camshafts and valve lifters can be serviced without engine tilting.

Marks 1 thru 16 on the camshaft holders mean position of holders to be installed; 1 to 8 are for EXHAUST side and 9 to 16 for INTAKE side from left to right respectively. When installing, be sure the mark  faces forward.

### SPECIAL TOOLS

#### Special Tools

Valve Guide Reamer 07984-2000000

Valve Lifter Hole Protector 07999-4220000

#### Common Tools

Valve Guide Remover (5.5 mm) 07742-0010100

Valve Spring Compressor 07757-0010000

### TORQUE VALUES

Cylinder head cover	0.8-1.2 kg-m ( 6- 9 ft-lb)
Camshaft holder	1.2-1.4 kg-m ( 9-10 ft-lb)
Cylinder head-8mm cap nut	1.9-2.1 kg-m (14-15 ft-lb)
Cylinder head-10mm cap nut	3.2-3.4 kg-m (23-25 ft-lb)
Cylinder head-8mm flange bolt	1.8-2.2 kg-m (13-16 ft-lb)
Cam sprocket	1.4-1.8 kg-m (10-13 ft-lb)
Spark plug	1.2-1.6 kg-m ( 9-12 ft-lb)

### SPECIFICATIONS

			STANDARD	SERVICE LIMIT
Compression ratio			12±1 kg/cm <sup>2</sup> (171±14 psi)	—
Camshaft	Cam height	IN.	37.300-37.460 mm (1.4685-1.4748 in)	37.2 mm (1.46 in)
		EX.	37.500-37.660 mm (1.4763-1.4827 in)	37.4 mm (1.47 in)
	Oil clearance	No. 1 and 9	0.040-0.082 mm (0.0016-0.0032 in)	0.12 mm (0.005 in)
		No. 2 and 10	0.063-0.105 mm (0.0025-0.0041 in)	0.14 mm (0.006 in)
		No. 3 and 11	0.063-0.105 mm (0.0025-0.0041 in)	0.14 mm (0.006 in)
		No. 4 and 12	0.040-0.082 mm (0.0016-0.0032 in)	0.12 mm (0.005 in)
		No. 5 and 13	0.040-0.082 mm (0.0016-0.0032 in)	0.12 mm (0.005 in)
		No. 6 and 14	0.063-0.105 mm (0.0025-0.0041 in)	0.14 mm (0.006 in)
		No. 7 and 15	0.063-0.105 mm (0.0025-0.0041 in)	0.14 mm (0.006 in)
		No. 8 and 16	0.040-0.082 mm (0.0016-0.0032 in)	0.12 mm (0.005 in)
Run out		—	0.03 mm (0.001 in)	





		STANDARD		SERVICE LIMIT
Valve lifter	Valve lifter O.D.	27.972–27.993 mm (1.1013–1.1021 in)		27.96 mm (1.101 in)
	Cylinder head I.D.	28.000–28.021 mm (1.1024–1.1032 in)		28.03 mm (1.104 in)
	Lifter to cylinder head clearance	—		0.07 mm (0.003 in)
Valve spring	Free length	IN. Outer	43.9 mm (1.73 in)	42.5 mm (1.67 in)
		IN. Inner	40.7 mm (1.60 in)	39.8 mm (1.57 in)
		EX. Outer	43.9 mm (1.73 in)	42.5 mm (1.67 in)
		EX. Inner	40.7 mm (1.60 in)	39.8 mm (1.57 in)
	Preload/length	IN. Outer	12.6–14.6 kg/37.5 mm (27.78–32.19 lbs/1.48 in)	12.0 kg/37.5 mm (26.46 lbs/1.48 in)
		IN. Inner	6.39–7.81 kg/34.5 mm (14.087–17.218 lbs/1.36 in)	6.0 kg/34.5 mm (13.23 lbs/1.36 in)
		EX. Outer	12.6–14.6 kg/37.5 mm (27.78–32.19 lbs/1.48 in)	12.0 kg/37.5 mm (26.46 lbs/1.48 in)
		EX. Inner	6.39–7.81 kg/34.5 mm (14.087–17.218 lbs/1.36 in)	6.0 kg/34.5 mm (13.23 lbs/1.36 in)
Valve guide	Valve stem O.D.	IN	5.475–5.490 mm (0.2156–0.2161 in)	5.47 mm (0.215 in)
		EX.	5.455–5.470 mm (0.2148–0.2154 in)	5.45 mm (0.215 in)
	Valve guide I.D.	IN.	5.500–5.512 mm (0.2165–0.2170 in)	5.54 mm (0.218 in)
		EX.	5.500–5.512 mm (0.2165–0.2170 in)	5.54 mm (0.218 in)
	Stem-to-guide clearance	IN.	—	0.07 mm (0.003 in)
		EX.	—	0.09 mm (0.004 in)
Valve seat width	0.90–1.10 mm (0.035–0.043 in)		1.5 mm (0.06 in)	
Cylinder head	Warpage	—		0.10 mm (0.004 in)
Cam chain	Length	169.70–169.92 mm (6.681–6.690 in)		170.7 mm (6.72 in)

## TROUBLESHOOTING

Engine top-end problems are usually performance-related and can be diagnosed by a compression test, or are engine noises which can be traced to the top-end with a sounding rod or stethoscope.

### Low Compression or Uneven Compression

- Valves
  - Incorrect valve adjustment
  - Burned or bent valves
  - Incorrect valve timing
  - Broken valve spring
- Cylinder head
  - Leaking or damaged head gasket
  - Warped or cracked cylinder head
- Cylinder and piston (Refer to Section 7)

### Compression too High

- Excessive carbon build-up on piston head or combustion chamber

### Excessive Noise

- Incorrect valve adjustment
- Sticking valve or broken valve spring
- Damaged or worn camshaft
- Loose or worn cam chain
- Worn or damaged cam chain tensioner
- Worn cam sprocket teeth



### CAMSHAFT REMOVAL

Place the motorcycle on its side stand for 2-3 minutes to allow oil to drain from the cylinder head to the sump. Then, place the motorcycle on its center stand.

Disconnect the tachometer cable and remove the tachometer drive gear.

#### CAUTION

*The tachometer driven gear must be removed to prevent No. 4 camshaft holder breakage when the camshafts are rotated. Camshaft holder breakage necessitates cylinder head assembly replacement.*



Remove the four cylinder head side covers. Remove the cylinder head cover bolts and the cylinder head cover. Remove the oil pool plates. Remove the oil pipes and cam chain guide. Remove the No. 4, No. 5, No. 12 and No. 13 camshaft holders. Remove the dowel pins.

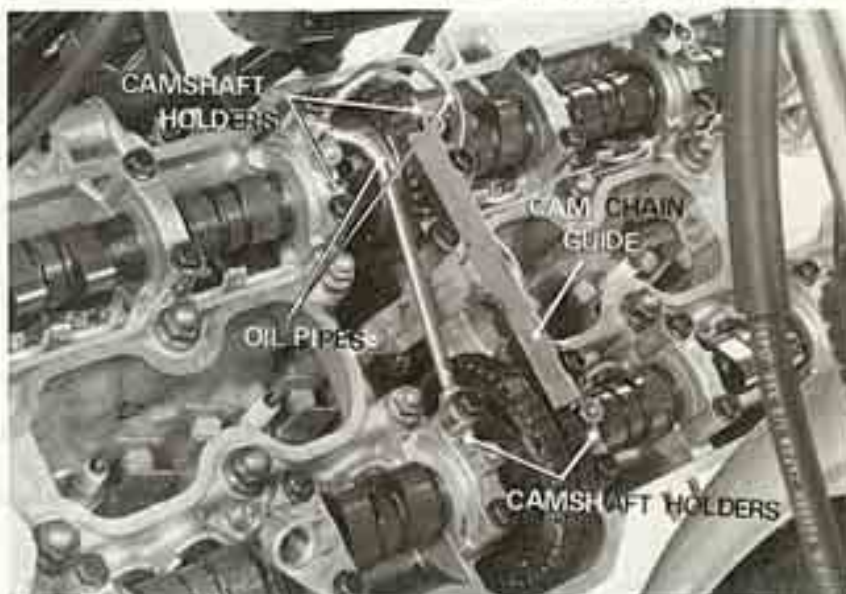

Loosen the front cam chain tensioner lock nut and bolt.

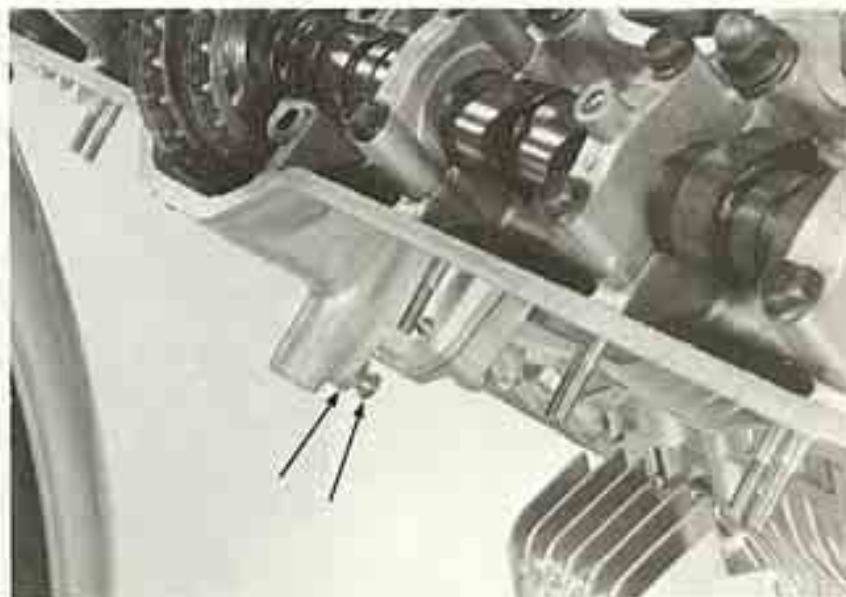





**CYLINDER HEAD/VALVE**

Press the cam chain tensioner down to reduce chain tension.  
Tighten the lock bolt and nut.



Loosen the rear cam chain tensioner lock nut.

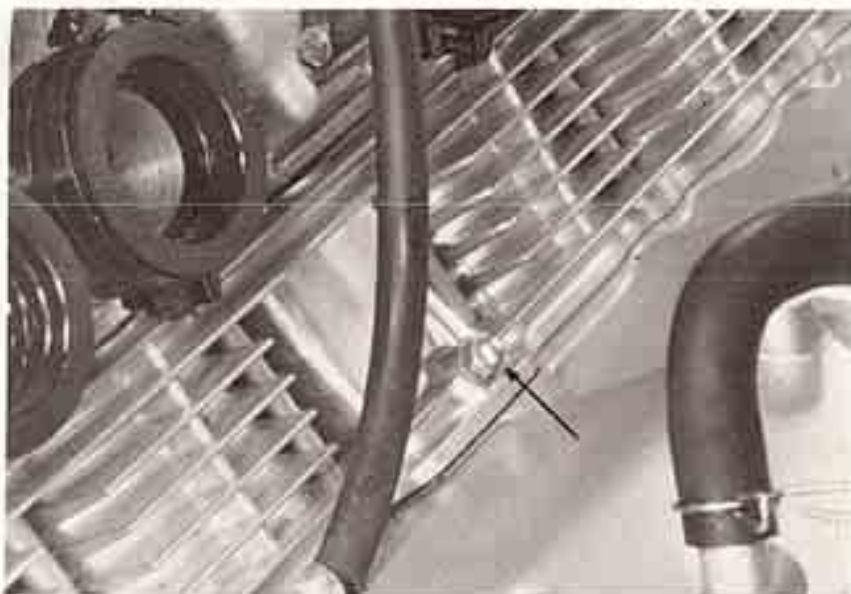

Pull the cam chain tensioner up to reduce chain tension and tighten the bolt and lock nut.





Remove the right crankshaft side cover.  
Turn the crankshaft clockwise until "T"  
mark on the crankshaft end aligns with the  
forward crankcase mating surface.



Make sure the No. 1 cylinder intake and  
exhaust cam lobes face the spark plug.  
If they do not, turn the crankshaft 360  
degrees clockwise and realign the "T" mark.  
Remove the No. 2 and 10 camshaft holders.  
Remove the No. 1, 9, 3 and 11 holders.  
Remove the dowel pins.

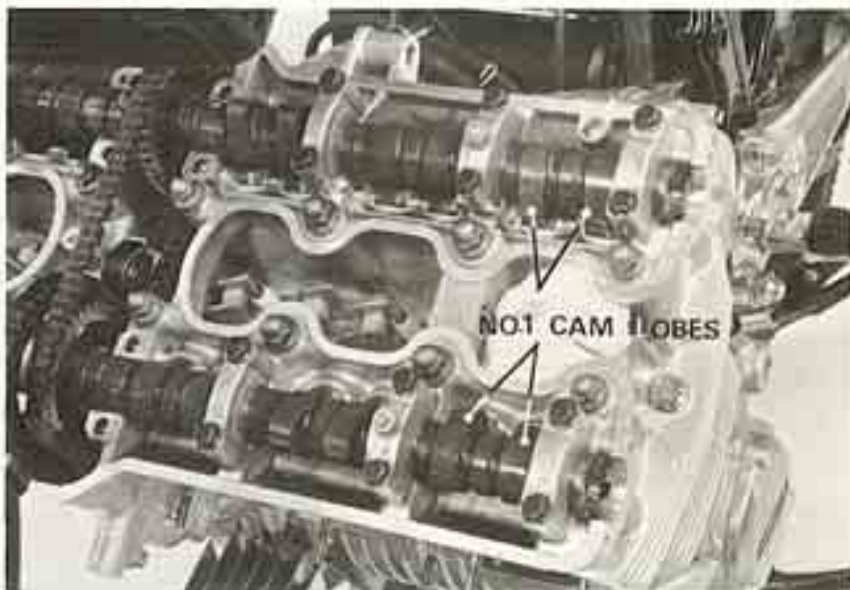

Remove the left camshafts and joints.

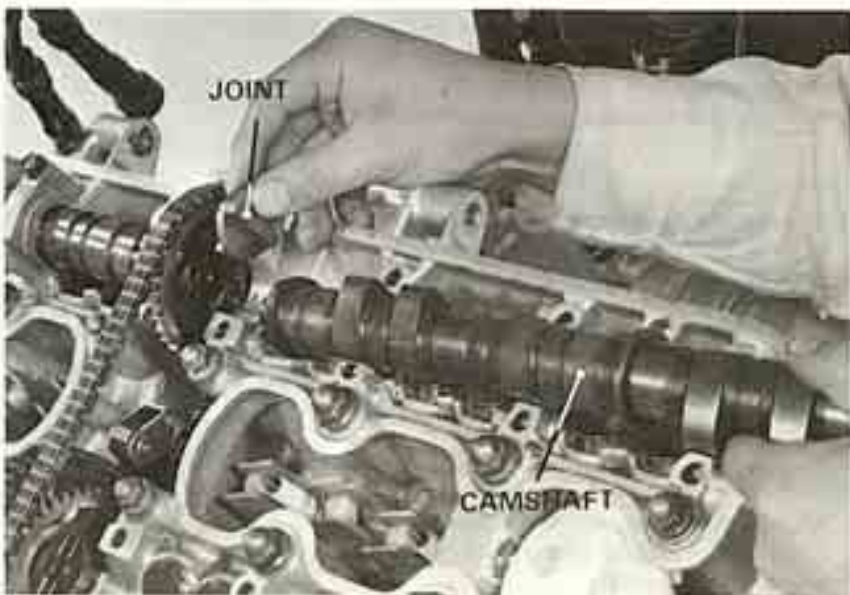





**CYLINDER HEAD/VALVE**

Turn the crankshaft 360 degrees clockwise and realign the "T" mark with the crankcase mating surfaces.

The No.6 intake and exhaust cam lobes face the spark plug.

Remove the No.15 camshaft holder.

Then remove the No.16 and 14 camshaft holders.

Remove the dowel pins.



Remove the right intake camshaft.

Loosen the cam sprocket bolt.

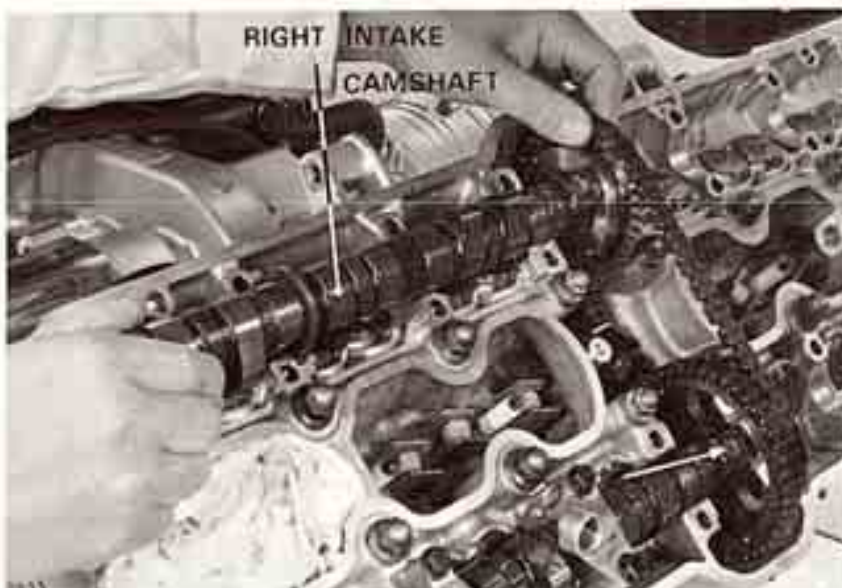

Turn the crankshaft clockwise until cam lift is minimal and the other cam sprocket bolt can be removed.

Remove the cam sprocket with the cam chain.

**NOTE**

Suspend the cam chain with a piece of wire to keep it from falling into the cylinder.

Remove the No. 7 camshaft holder, then remove the No. 8 and 6 camshaft holders. Remove the right exhaust camshaft.

**NOTE**

After removing the camshaft, the valve clearance adjusting shims and valve lifters can be removed.

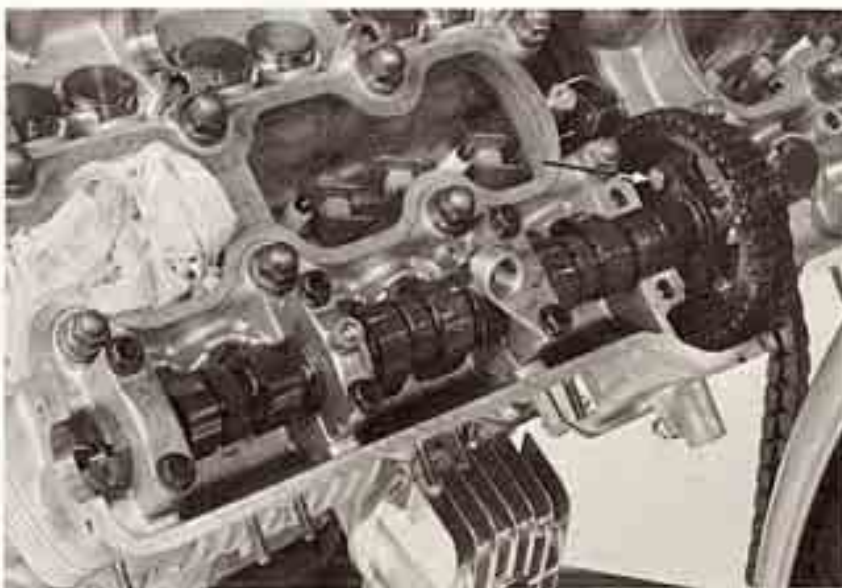



### CAM BEARING SURFACE INSPECTION

Inspect the cam bearing surfaces for scoring, scratches, or evidence of insufficient lubrication.  
Inspect the bearing surface of the camshaft holders.

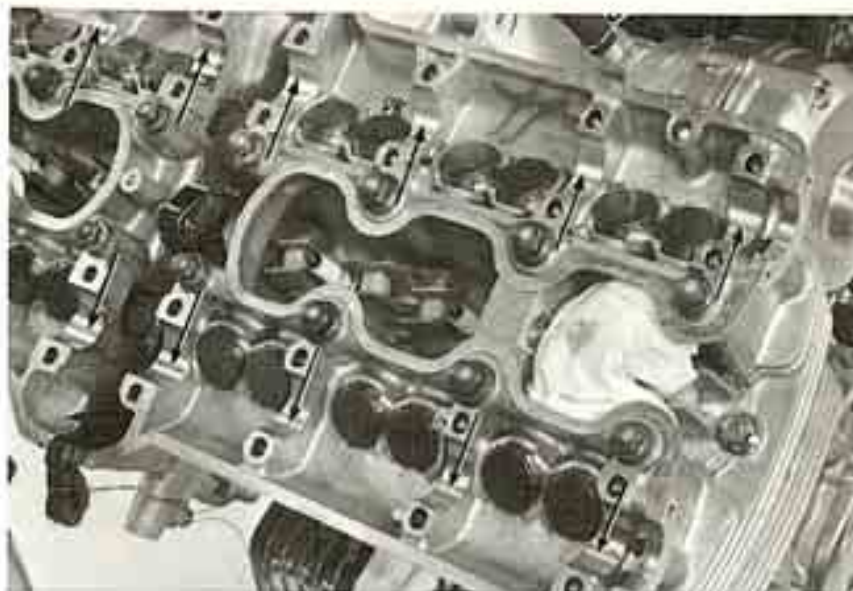

### CAMSHAFT RUNOUT

Check the camshaft runout with a dial gauge.  
Support both ends of the camshaft with V-blocks.



### CAM LOBE INSPECTION

Measure the height of each cam lobe.  
Inspect the cam lobes for wear or damage.







### CAM CHAIN LENGTH MEASUREMENT

Place the cam chain over the intake camshaft sprockets. Secure one sprocket and apply 2–10 kg (4.4–22 lb) of tension with a spring scale. Measure the distance between the points as shown.

**SERVICE LIMIT:** 170.7 mm (6.72 in)

### CAM CHAIN GUIDE INSPECTION

Inspect the cam chain guide for damage or local or excessive wear.

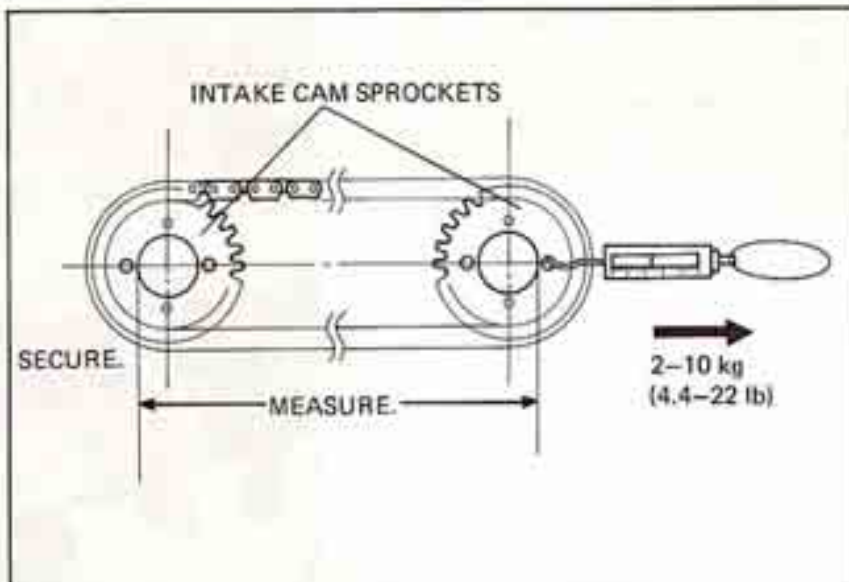

### CAMSHAFT OIL CLEARANCE

Remove the adjusting shims and the valve lifters.

#### NOTE

Mark each part to ensure original assembly.



Lay a strip of plastigauge lengthwise on top of each camshaft journal.

#### NOTE

Wipe any oil from the journals before using plastigauge.

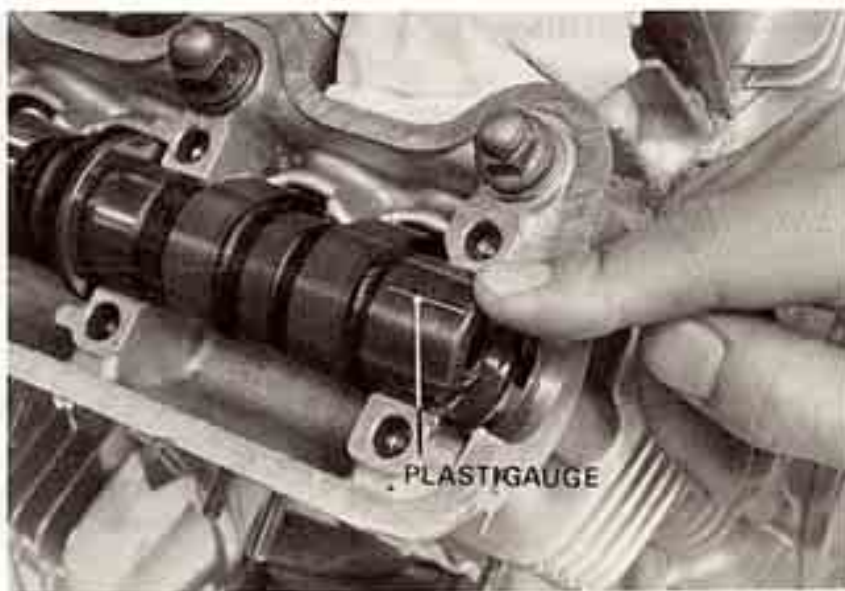



Determine the camshaft holder identification number before installing.

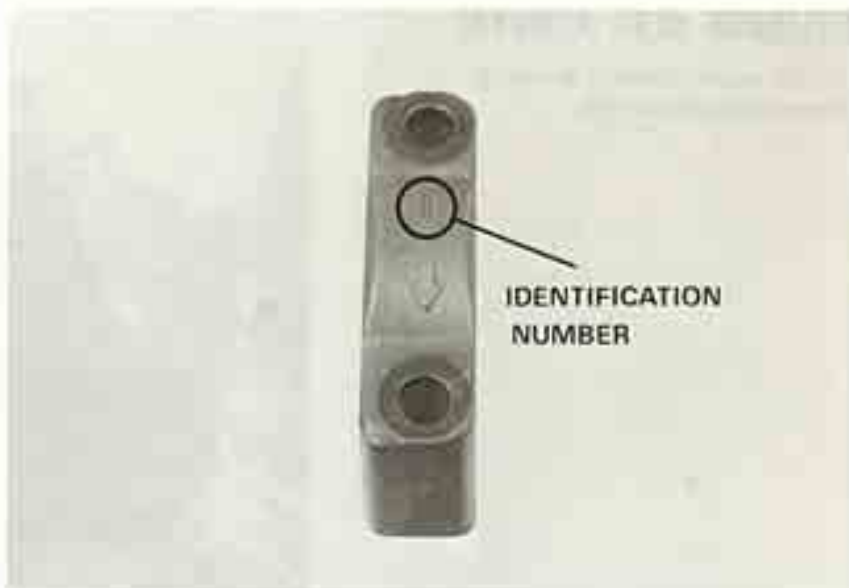

Install the camshaft holders and tighten to the specified torque in a crisscross pattern.

#### NOTE

Do not rotate the camshaft when using plastigauge.

**TORQUE: 1.2–1.4 kg-m (9–10 ft-lb)**

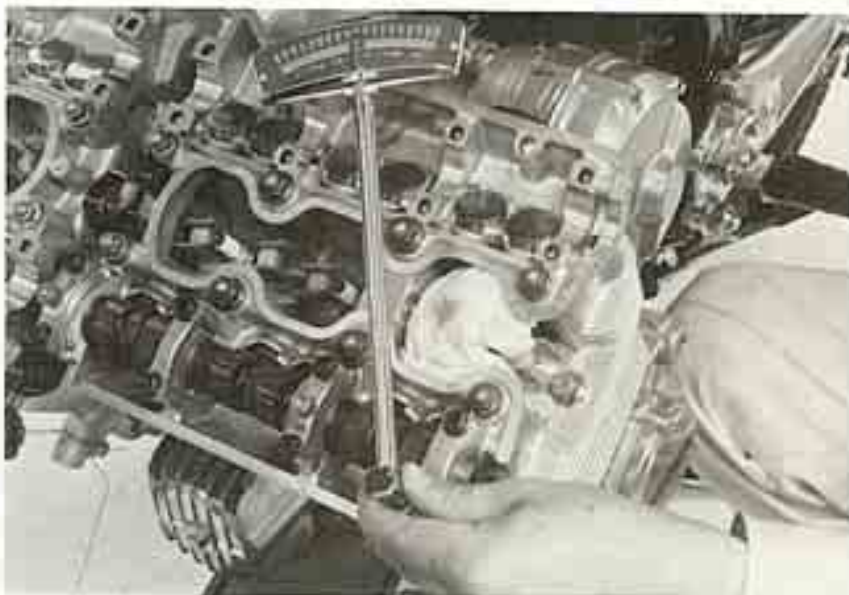

Remove the camshaft holders and measure the width of each Plastigauge. The widest thickness determines the oil clearance.

#### SERVICE LIMITS:

No. 1, 4, 5, 8, 9, 12, 13 and 16:

0.12 mm (0.005 in)

No. 2, 3, 6, 7, 10, 11, 14 and 15:

0.14 mm (0.006 in)

When the service limits are exceeded, replace the camshaft and recheck the oil clearance. Replace the cylinder head and camshaft holders if the clearance still exceeds service limits.

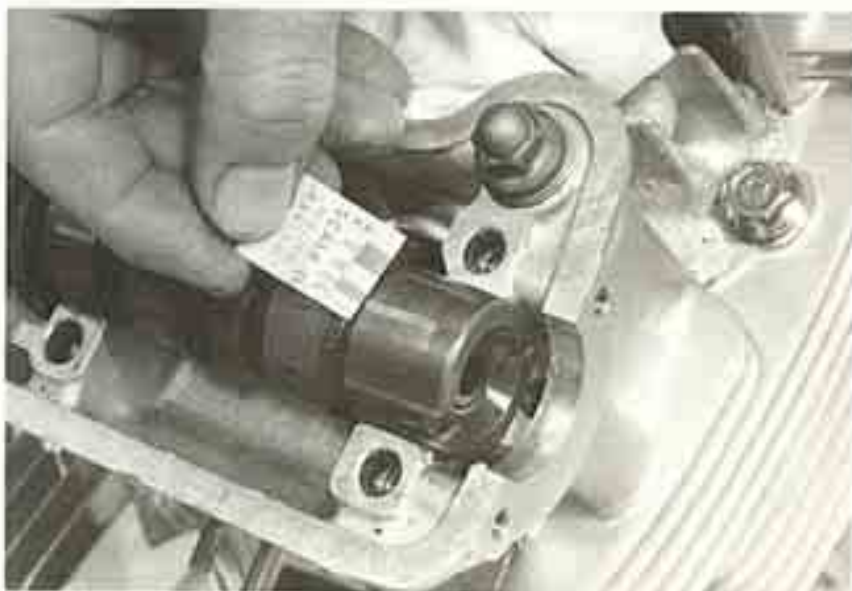





## CYLINDER HEAD REMOVAL

Tilt the engine (Refer to Section 5).  
Remove the oil hose bolt.

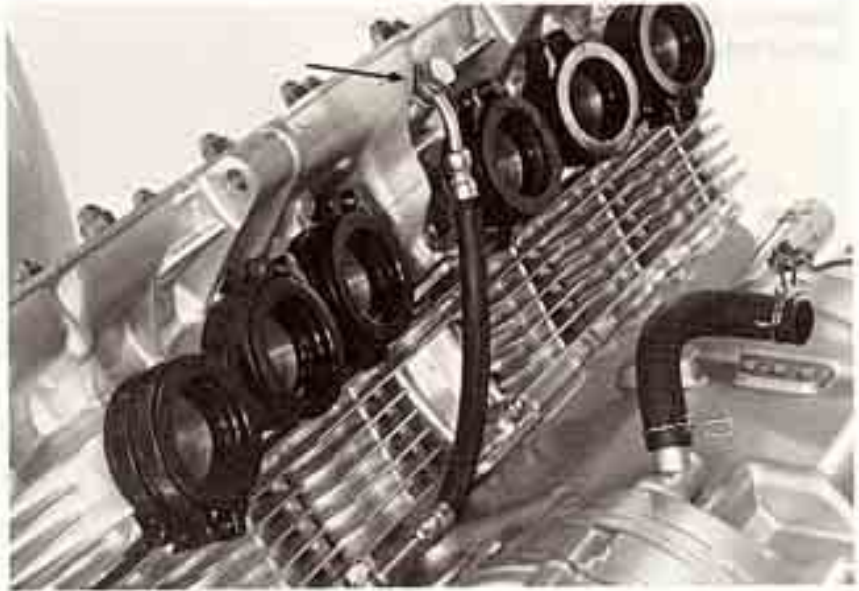

Remove the rear cam chain tensioner bolt.

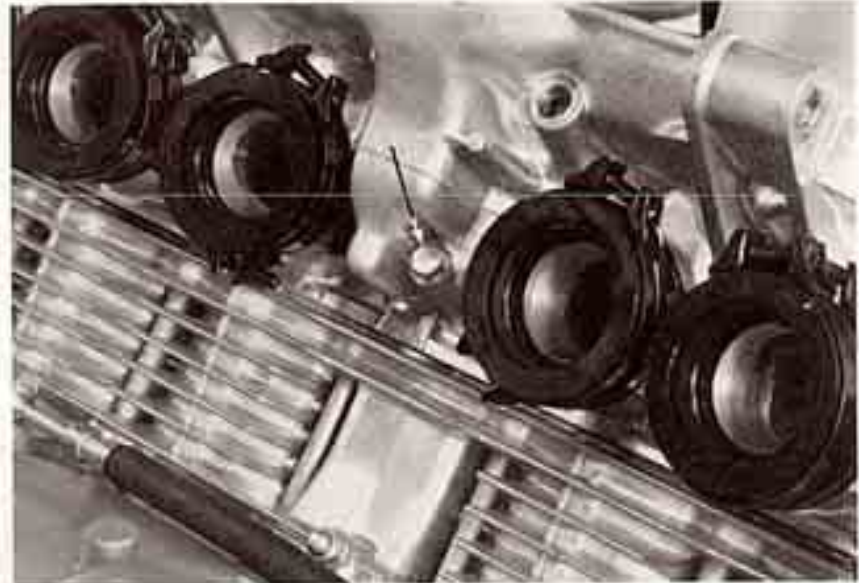

Remove the two cam chain housing bolts.

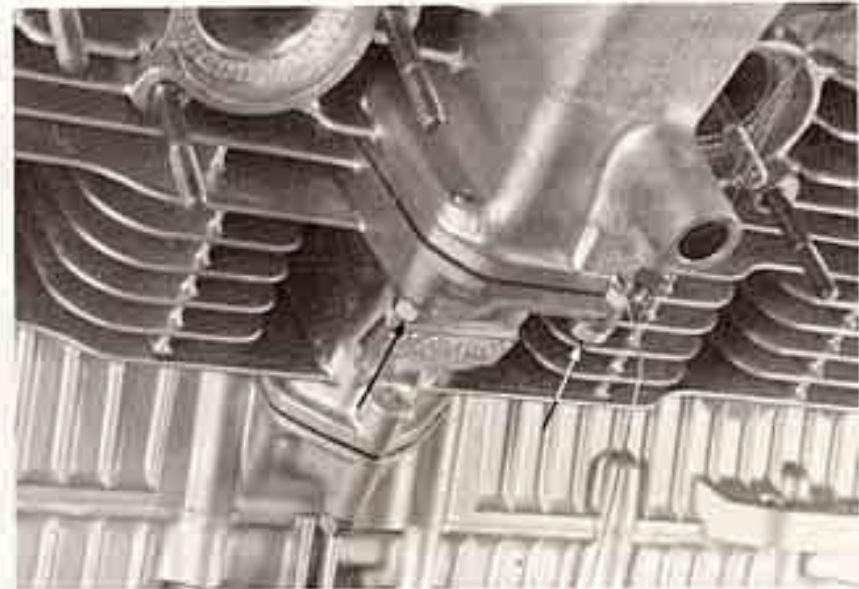



Remove the 16 cap nuts and two bolts.

### NOTE

Remove the nuts and bolts in 2-3 steps and in a crisscross pattern to prevent warpage.

Remove the cylinder head.



Remove the cylinder head gasket, dowel pins, and cam chain guide.

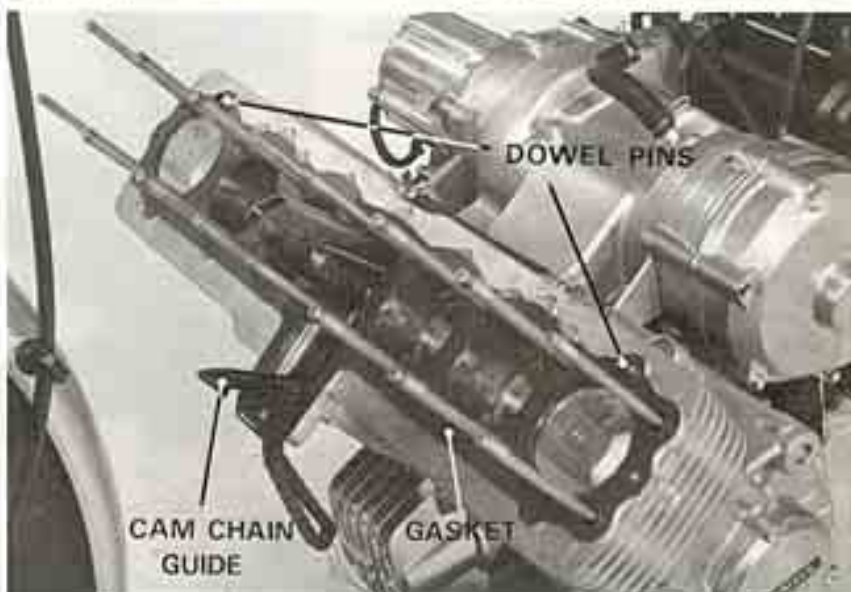

## CYLINDER HEAD DISASSEMBLY

Remove the valve shims.  
Remove the valve lifters.

### NOTE

Mark all disassembled parts to ensure original assembly.

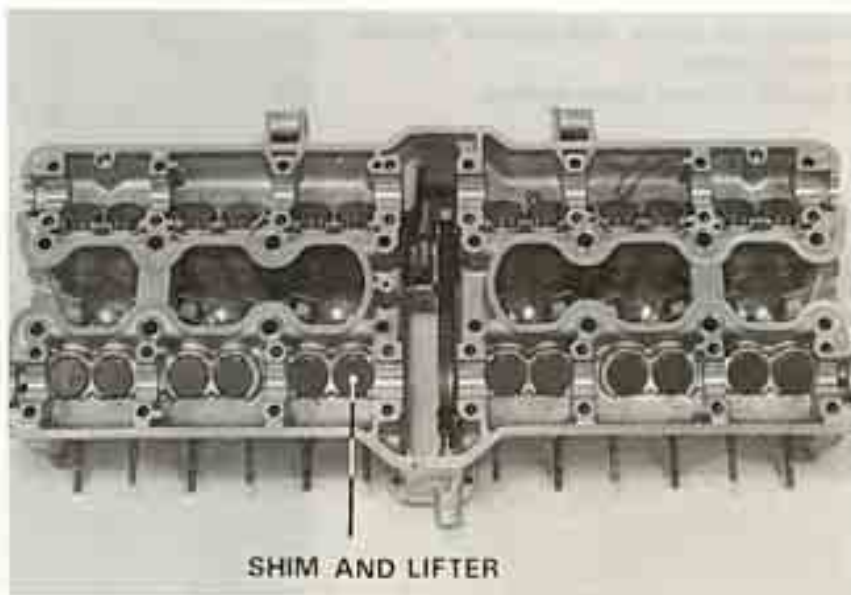





**CYLINDER HEAD/VALVE**

Loosen the cam chain tensioner lock nut and bolts.  
Remove the bolt in the cylinder head.  
Pull the chain tensioner back and remove.

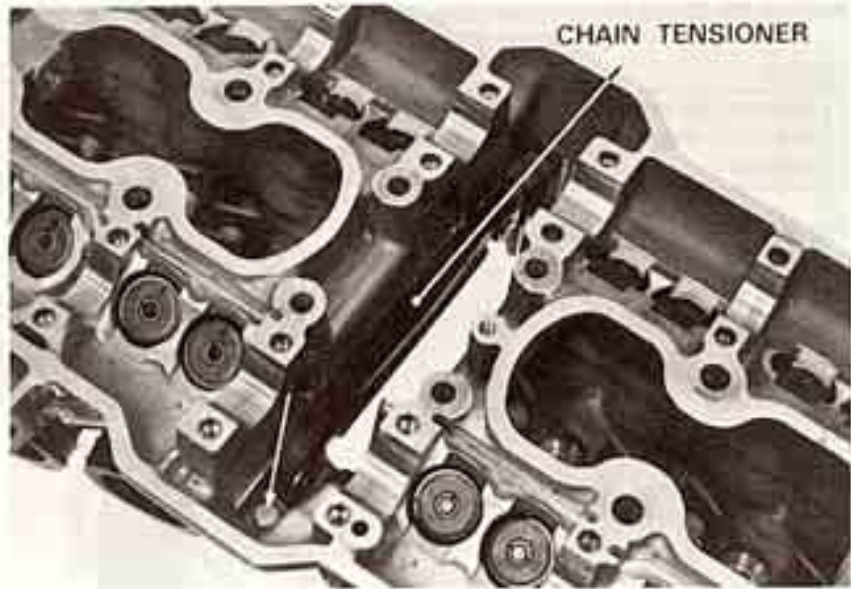

Remove the valve spring keepers, retainers, springs and valves.

**CAUTION**

*To prevent loss of tension, do not compress the valve springs more than necessary to remove the keepers.*

**NOTE**

Avoid damaging the lifter sliding surface.

**NOTE**

Mark all disassembled parts to ensure original assembly.



Remove the valve stem seals.

Remove the carbon deposits from the combustion chamber.  
Clean off the head gasket surfaces.

**NOTE**

- Avoid damaging the gasket surfaces.
- Gasket will come off easier if soaked in solvent.

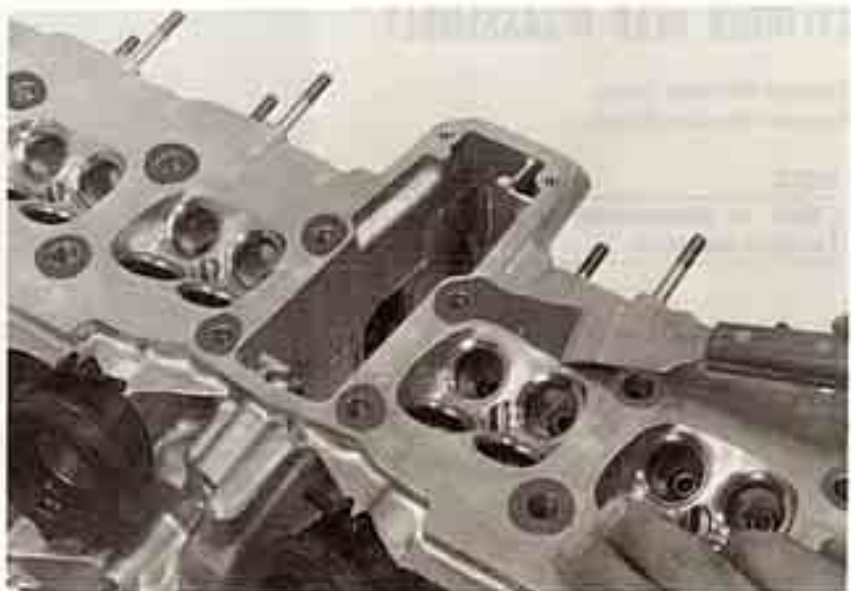



**VALVE LIFTER O.D.  
MEASUREMENT**

Measure the valve lifter O. D..



**CYLINDER HEAD I.D.  
MEASUREMENT**

Measure the cylinder head I. D..



**CYLINDER HEAD INSPECTION**

Inspect the sliding surfaces for scoring, scratches, or evidence of insufficient lubrication.

Check the spark plug hole and valve areas for cracks.

Check the cylinder head for warpage with a straight edge and a feeler gauge.

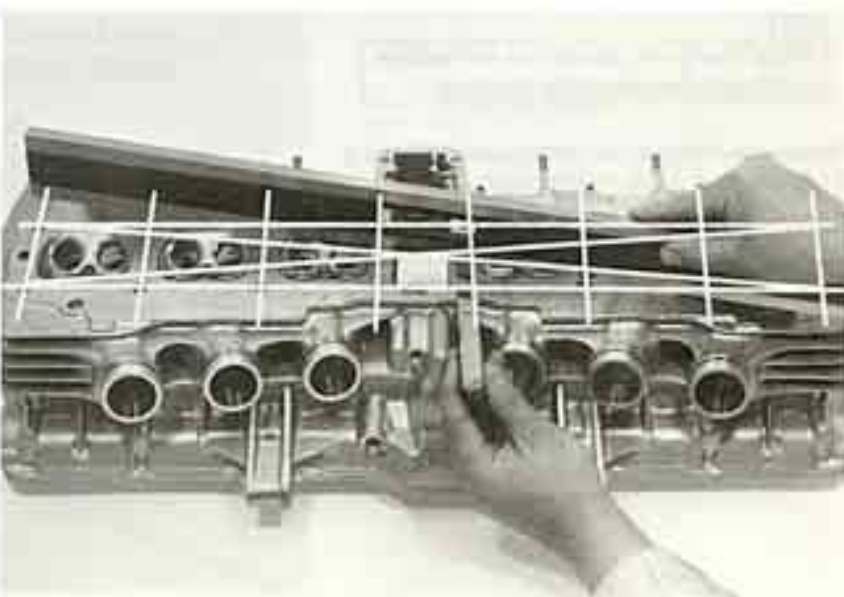





**CYLINDER HEAD/VALVE**

**VALVE SPRING FREE LENGTH INSPECTION**

Measure the length of the inner and outer valve springs.

**SERVICE LIMITS:**

- Inner: IN. 39.8 mm (1.57 in)
- EX. 39.8 mm (1.57 in)
- Outer: IN. 42.5 mm (1.67 in)
- EX. 42.5 mm (1.67 in)

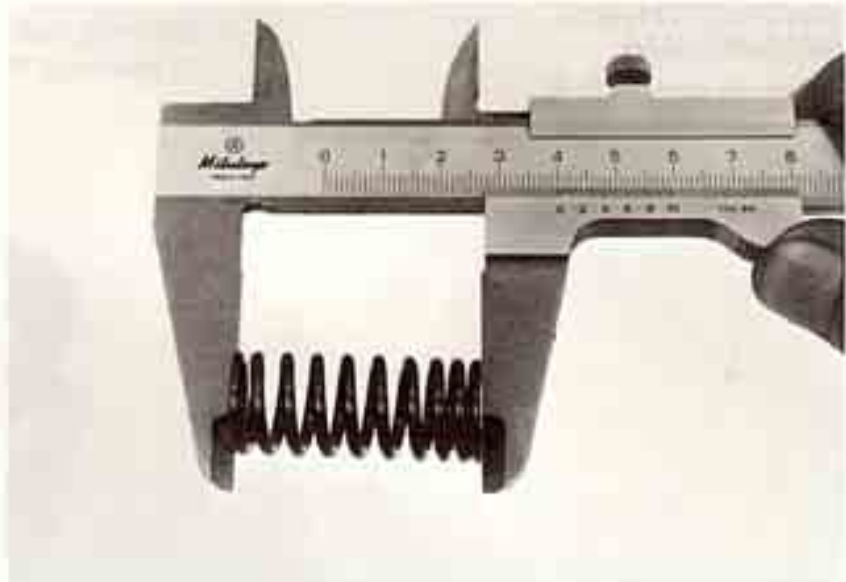

**VALVE STEM-TO-GUIDE CLEARANCE**

Inspect each valve for bending, burning, scratches or abnormal stem wear.

Check the valve movement in the guide.  
Measure and record each valve stem O.D.

**SERVICE LIMIT:**

- IN : 5.47mm (0.216in)
- EX: 5.45mm (0.215in)



**NOTE**

Ream the guides to remove any carbon build-up before checking clearance.

Measure and record each valve guide I.D. using a ball gauge or inside micrometer.

- SERVICE LIMITS:** IN. 5.54 mm (0.215 in)
- EX. 5.54 mm (0.215 in)

Subtract each valve stem O.D. from the corresponding guide I.D. to obtain the stem to guide clearance.

- SERVICE LIMITS:** IN. 0.07 mm (0.003 in)
- EX. 0.09 mm (0.004 in)





### NOTE

If the stem-to-guide clearance exceeds the service limits, determine if a new guide with standard dimensions would bring the clearance within tolerance. If so, replace any guides as necessary and ream to fit.

If stem-to-guide clearance exceeds the service limits with new guides, replace the valves and guides.

### NOTE

Reface the valve seats whenever the valve guides are replaced.



### CAM CHAIN GUIDE AND CAM CHAIN TENSIONER INSPECTION

Inspect the cam chain guide for damage or excessive wear.

Inspect the cam chain tensioner slipper for damage or excessive wear.

Inspect the tension spring for weakness.

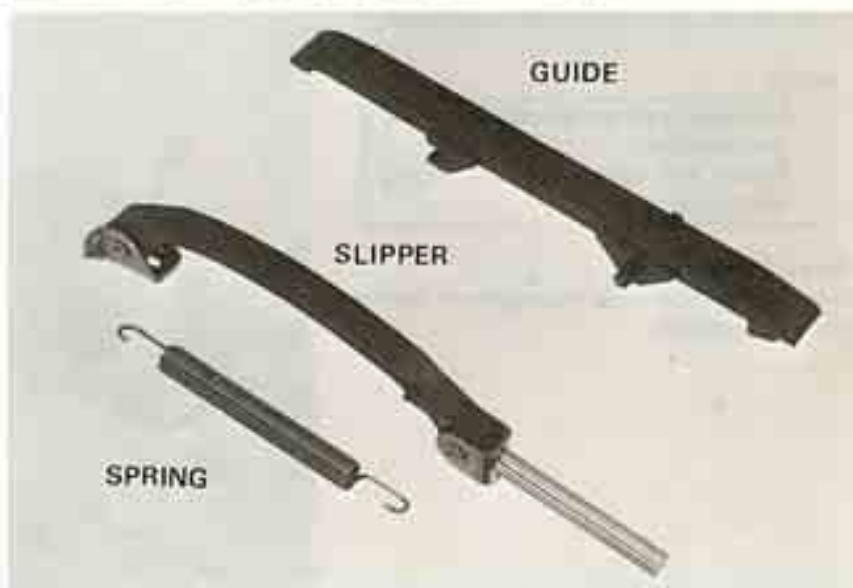

### VALVE GUIDE REPLACEMENT

Support the cylinder head and drive out the guide from the valve port.

### NOTE

When driving out the valve guide, do not damage the head.

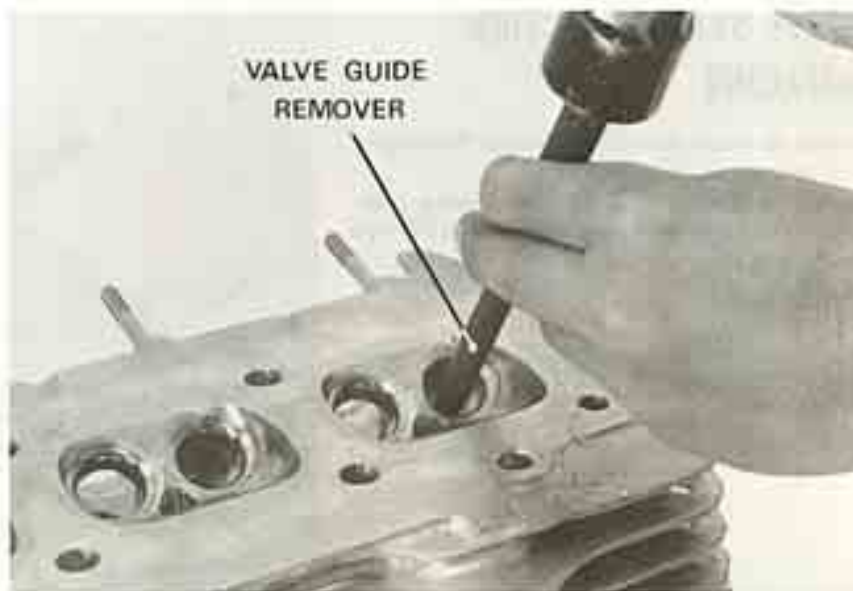





**CYLINDER HEAD/VALVE**

Install a new oversize valve guide from the top of the head.



Ream the new valve guide after installation.

**NOTE**

- Use cutting oil on the reamer during this operation.
- Rotate the reamer when inserting and removing it.

Reface the valve seat.  
Clean the cylinder head thoroughly to remove any metal particles.



**VALVE SEAT INSPECTION /  
REFACING**

Clean all intake and exhaust valves thoroughly to remove carbon deposits.  
Apply a light coating of valve lapping compound to each valve face. Lap each valve and seat using a rubber hose or other hand-lapping tool.

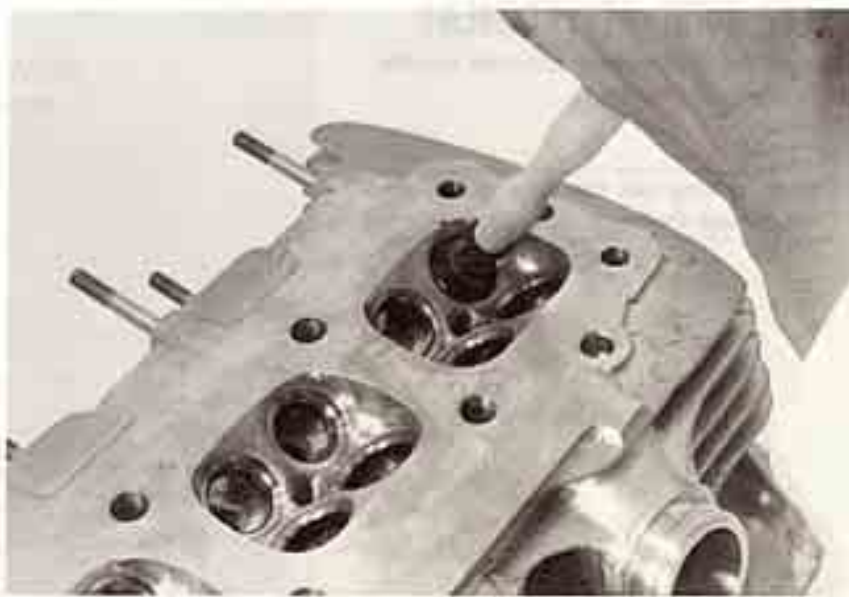



Remove the valve and inspect the face.

**CAUTION**

*The valves cannot be ground. If the valve face is rough, worn unevenly, or contacts the seat improperly, the valve must be replaced.*

Inspect the valve seat.

If the seat is too wide, too narrow, or has low spots, the seat must be ground.

**NOTE**

Follow the refacer manufacturer's operating instructions.

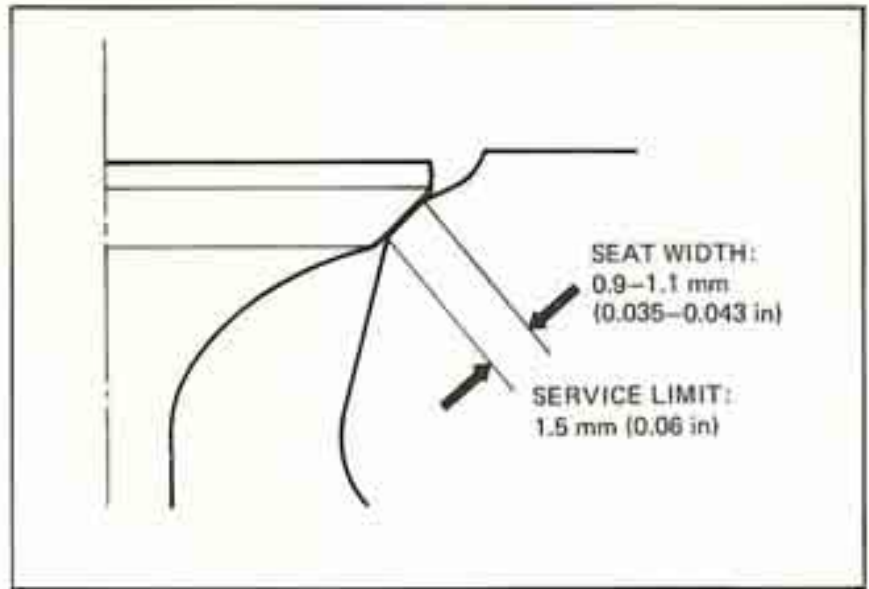

CUTTER NO. 07780-0012100 (28 φ)    CUTTER NO. 07780-0014000 (30 φ)    CUTTER NO. 07780-0010200 (27.5 φ)

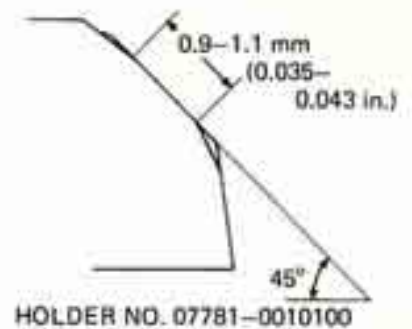
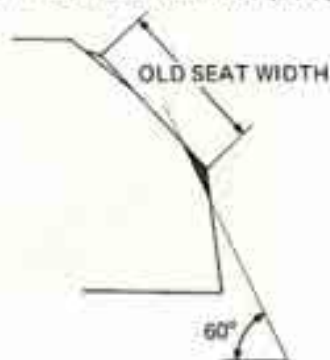
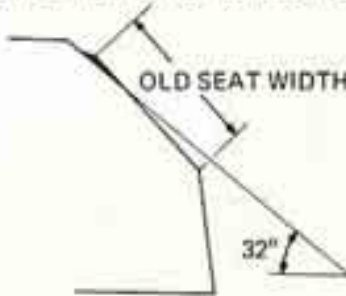

After cutting the seat, apply lapping compound to valve face, and lap the valve using light pressure.  
After lapping, wash any residual compound off the cylinder head and valve.

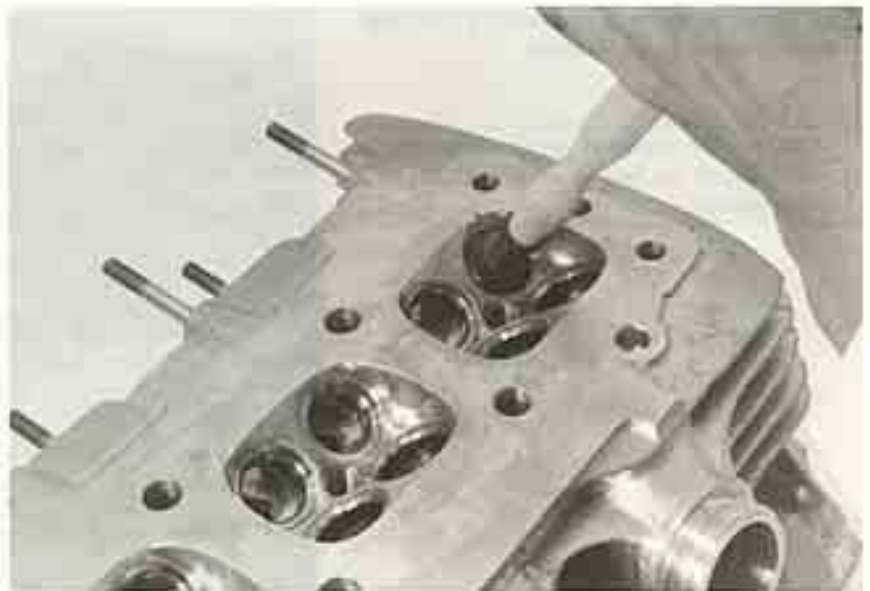





## CYLINDER HEAD ASSEMBLY

### NOTE

Install new valve stem seals when reassembling.

Lubricate each valve stem with molybdenum disulfide grease and insert the valve into the valve guide.

### NOTE

To avoid damage to the stem seal, turn the valve slowly when inserting.

Install the valve springs and retainers.

### NOTE

Install the valve springs with the tightly wound coils facing the cylinder head.

Install the valve keepers.

### CAUTION

To prevent loss of tension, do not compress the valve spring more than necessary to install the valve keepers.

Tap the valve stems gently with a soft hammer to firmly seat the keepers.

### NOTE

Support the cylinder head above the work bench surface to prevent possible valve damage.

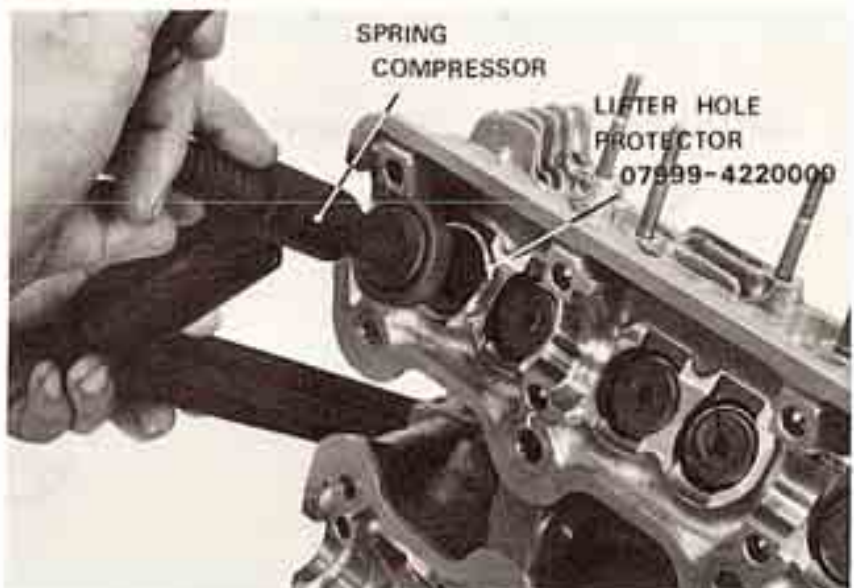
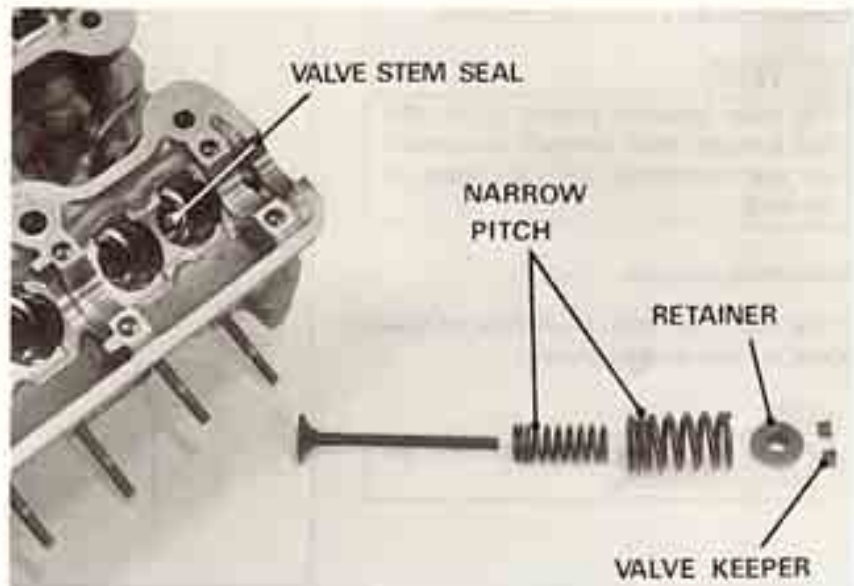



Install the cam chain tensioner.  
Push the chain tensioner and tighten the lock nut.

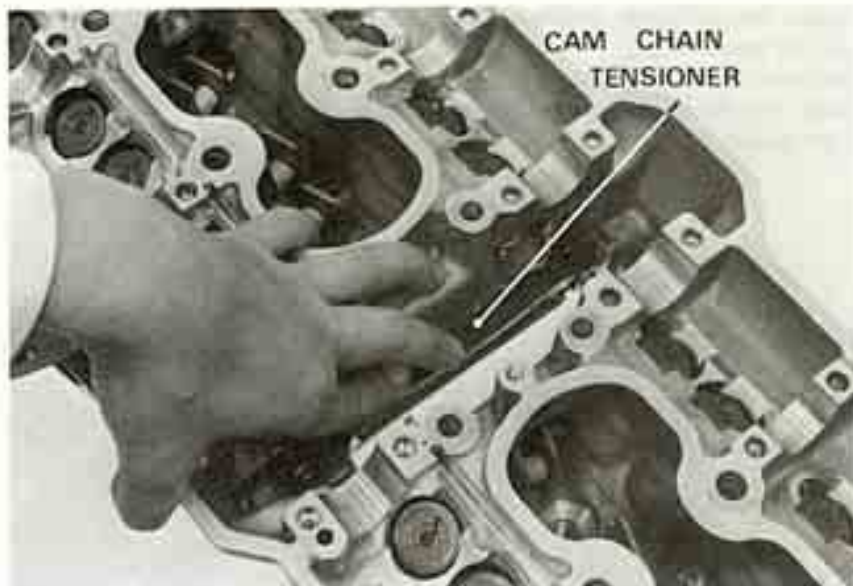

Install the valve lifters and adjustment shims.

**NOTE**

Make sure that the valve lifters and shims are in their original position.

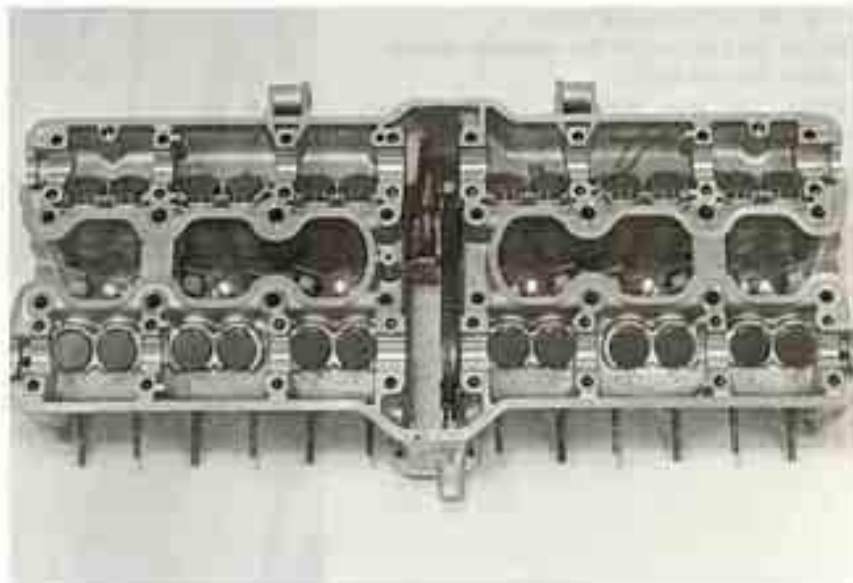

**CYLINDER HEAD INSTALLATION**

Clean the cylinder head gasket surfaces of any gasket material.







**CYLINDER HEAD/VALVE**

Loosen the cam chain tensioner lock nut and pull the tensioner up.  
Retighten the lock nut.  
Install the dowel pins, a new gasket and cam chain guide.



Install the cylinder head assembly.  
Tighten the cap nuts in the sequence shown.  
Tighten the two bolts.  
Tighten the two bolts at the cam chain housing.

**NOTE**

Apply molybdenum disulfide grease to the thread of the cylinder bolts and washers.

**TORQUE:**

- 10 mm cap nut: 3.2–3.4 kg-m (23–25 ft-lb)
- 8 mm cap nut: 1.9–2.1 kg-m (14–15 ft-lb)
- 8 mm bolt: 1.8–2.2 kg-m (13–16 ft-lb)

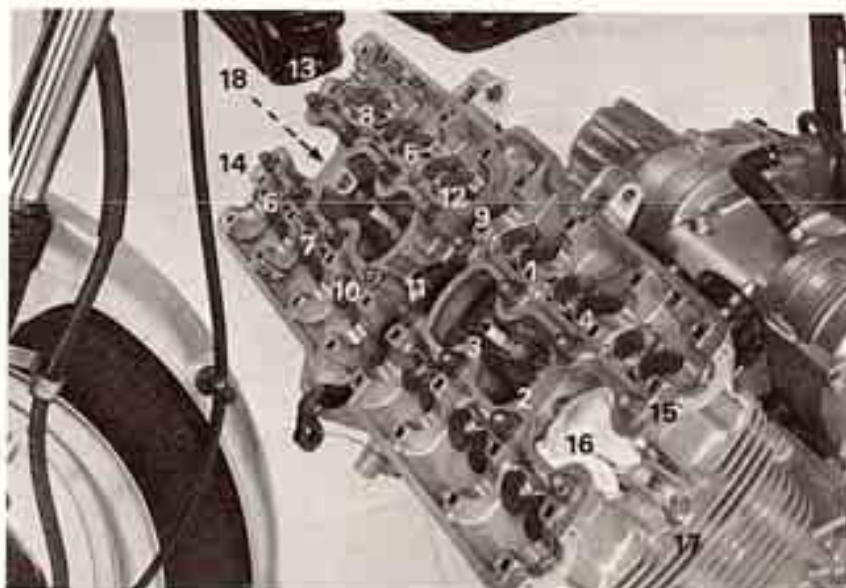

Tighten the cam chain tensioner bolt.  
**TORQUE: 1.0–1.4 kg-m (7-10 ft-lb)**

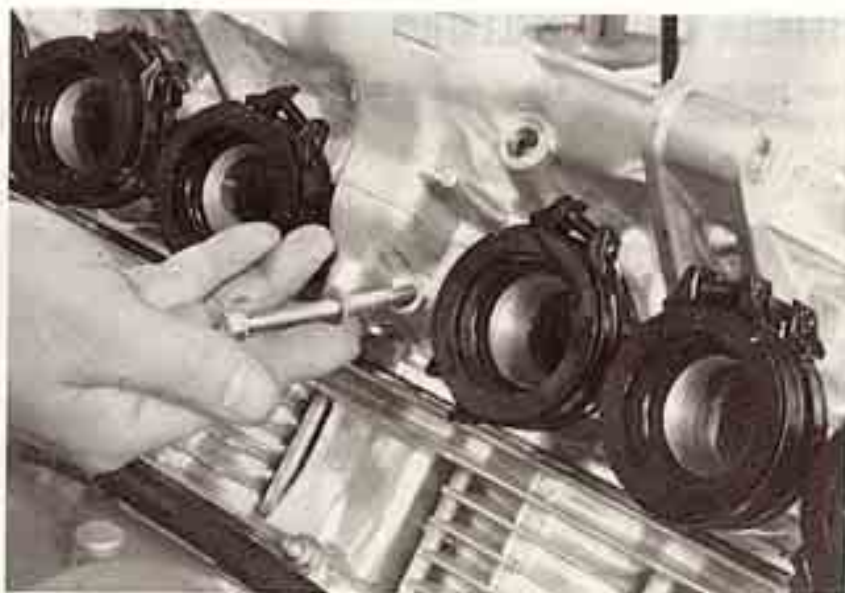



## CAMSHAFT INSTALLATION

Lubricate the camshaft bearings with molybdenum disulfide grease.



Turn the crankshaft clockwise until the "T" mark is toward the front of the engine and is aligned with the crankcase mating surfaces as shown.

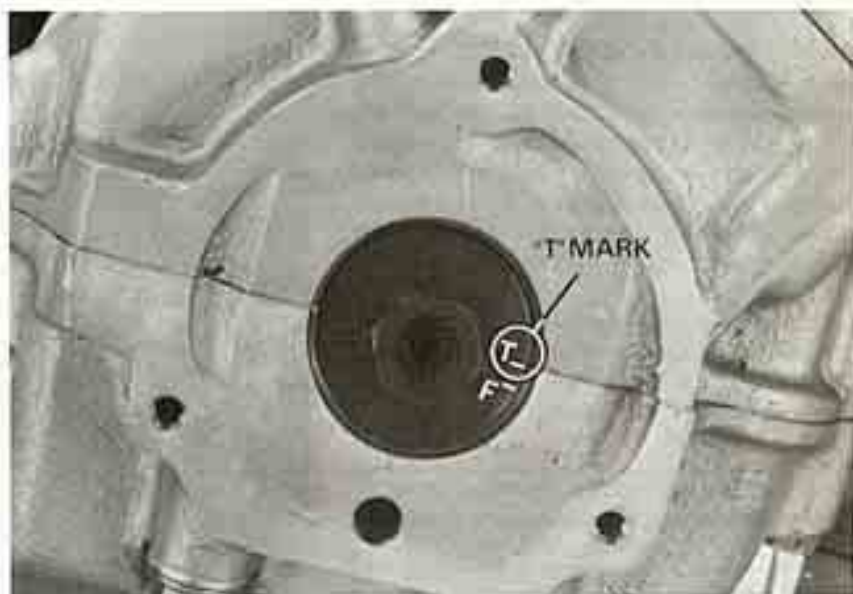

Place the cam chains over the exhaust camshaft sprocket, aligning the sprocket punch marks with the cylinder head surface. Install the right exhaust camshaft, positioning the cam lobes for the No. 6 cylinder toward the spark plug. Install a camshaft sprocket bolt, but do not tighten yet.

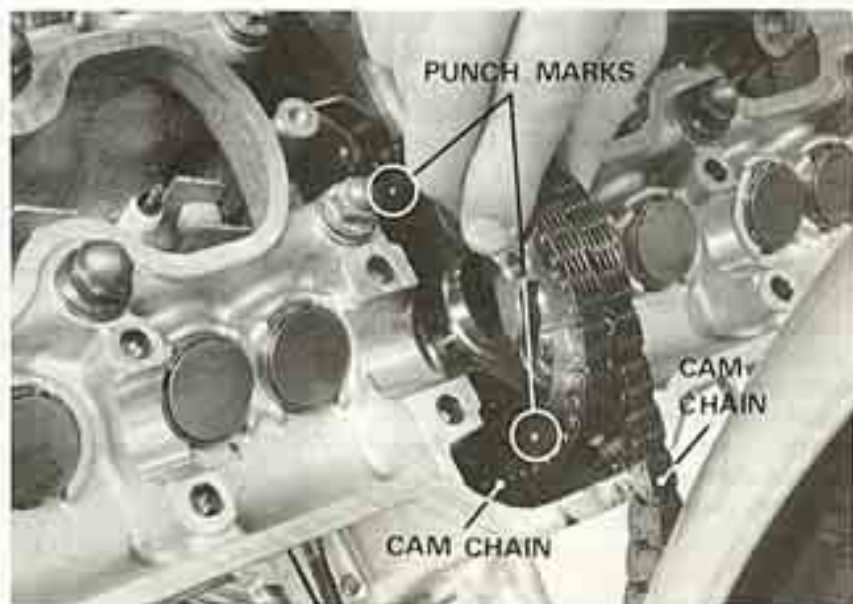





**CYLINDER HEAD/VALVE**

Loosely install the No. 6 and No. 8 camshaft holders. Install the No. 7 holder, positioning the camshaft so its flange fits into the slot in the No. 7 holder.

**NOTE**

Install camshaft holders with directional arrows pointing toward the front of the engine.

Tighten the camshaft holder bolts in a criss-cross pattern.

**TORQUE: 1.2-1.4 kg-m (9-10 ft-lb)**

Turn the crankshaft clockwise 360° to obtain access for installing the other camshaft sprocket bolt. Install the sprocket bolt and tighten to the specified torque.

**TORQUE: 1.4-1.8 kg-m (10-13 ft-lb)**

Turn the crankshaft another 360° and tighten the sprocket bolt which was installed earlier. Adjust the cam chain (page 3-14).



Position the crankshaft so the "T" mark is again aligned with the crankshaft mating surfaces as shown on page 6-21. Recheck the position of the exhaust camshaft sprocket; the punch marks must align with the cylinder head surface. Place the cam chain over the intake camshaft sprocket, aligning the sprocket punch marks with the cylinder head surface.

Install the right intake camshaft, positioning the cam lobes for the No. 6 cylinder toward the spark plugs. Install a camshaft sprocket bolt, but do not tighten yet.

**NOTE**

If the sprocket was not removed from the camshaft during disassembly, then reinstall as an assembled set.

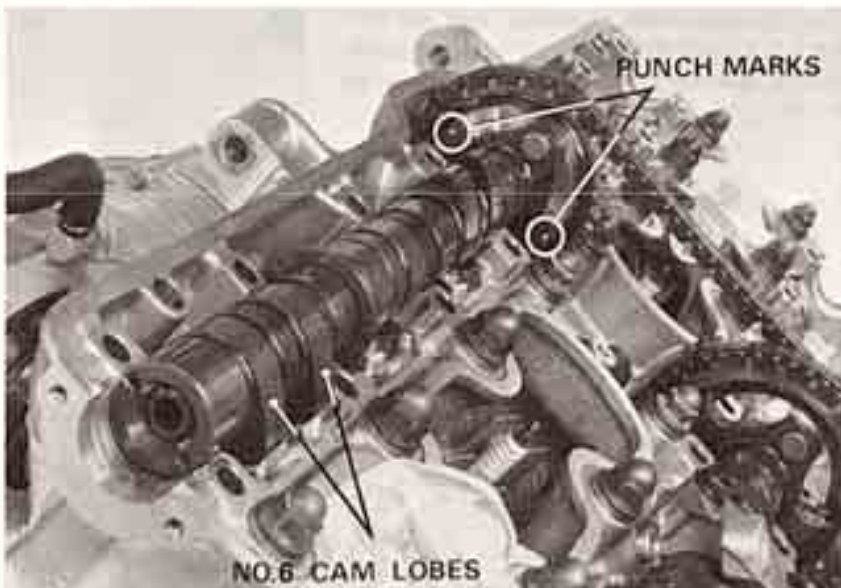

Loosely install the No. 14 and No. 16 camshaft holders. Install the No. 15 holder, positioning the camshaft so its flange fits into the slot in the No. 15 holder.

Tighten the camshaft holder bolts, then tighten the camshaft sprocket bolt, following the same procedure described for exhaust camshaft installation.

Turn the crankshaft clockwise 360° until the "T" mark is aligned with the crankcase mating surface. Make sure the cam lobes for the No. 6 cylinder are toward outside.

Install and tighten the camshaft sprocket bolt. Adjust the cam chain tensioner (page 3-14). Recheck the crankshaft and camshaft sprocket alignment.

Insert the camshaft joints into the camshaft ends.





Connect the left camshafts to the joints with No. 1 cam lobes toward the spark plug.  
Install No. 1, No. 3 and No. 9 and 11 holders loosely.  
Install the No. 2 and No. 10 holders.  
Tighten the bolts to the specified torque in a crisscross pattern.

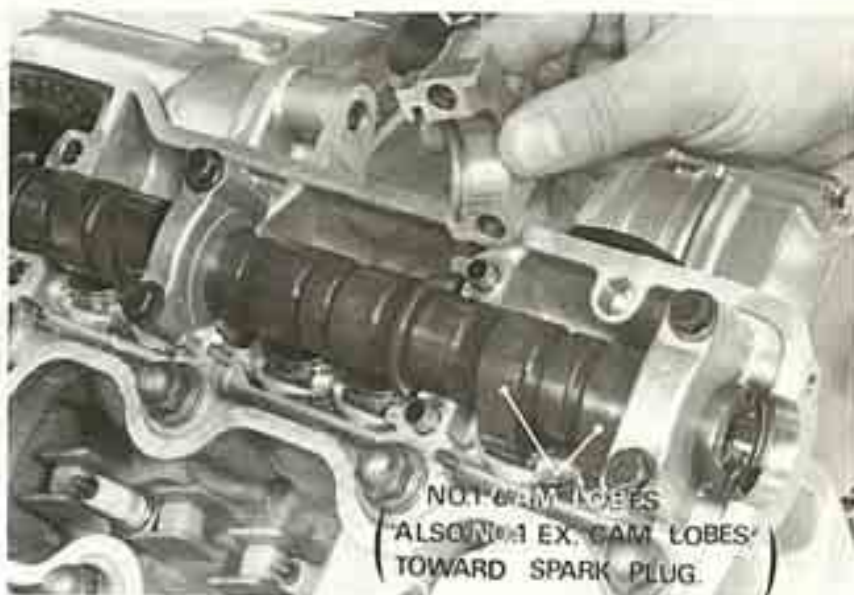

Install the oil pipes and cam chain guide with the No. 4, 5, 12 and 13 holders.  
Tighten in a crisscross pattern to the specified torque.



Install the engine.  
Fill the oil pockets in the head with oil so that the cam lobes are submerged.  
Adjust valve tappet clearance (Section 3).







**CYLINDER HEAD/VALVE**

Inspect the cylinder head cover gasket for damage or deterioration.

Apply a sealant on the cylinder gasket as shown, adjacent to each side cover.

**NOTE**

Before applying sealant, clean the gasket.

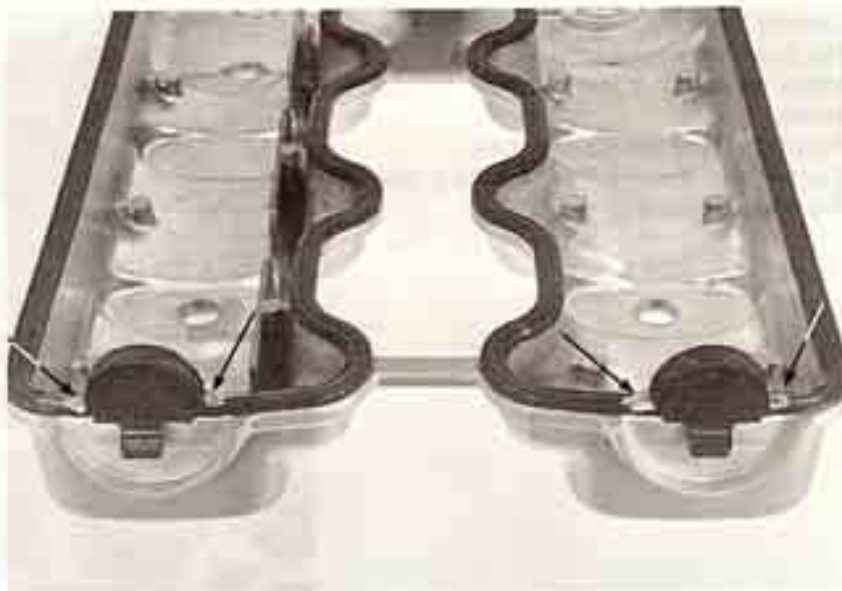

Install the cylinder head cover and cylinder head side covers.

Insert the tachometer drive gear.  
Install the tachometer gear cover.  
Connect the tachometer cable.

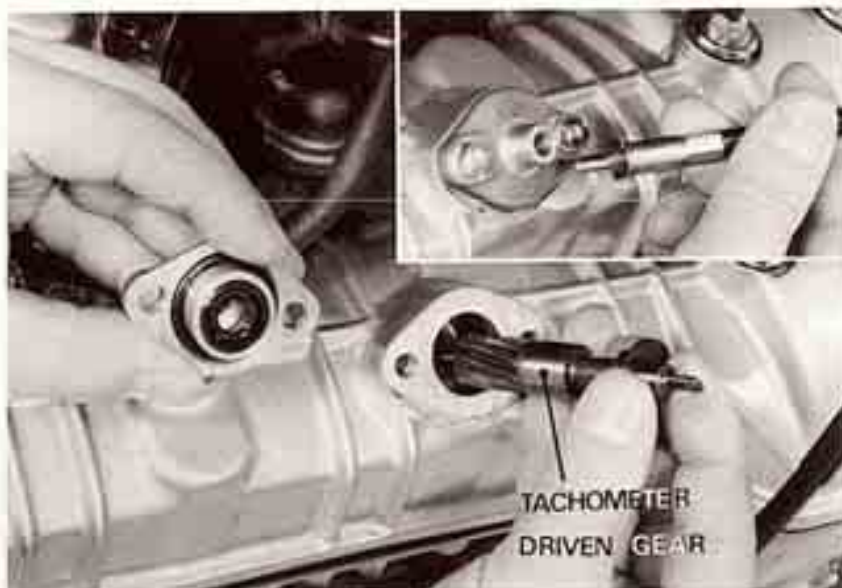

Install the right crankshaft side cover and gasket with bead printed surface toward the crankcase.

Install a new O-ring on the upper screw only.

Adjust the cam chain (page 3-14).



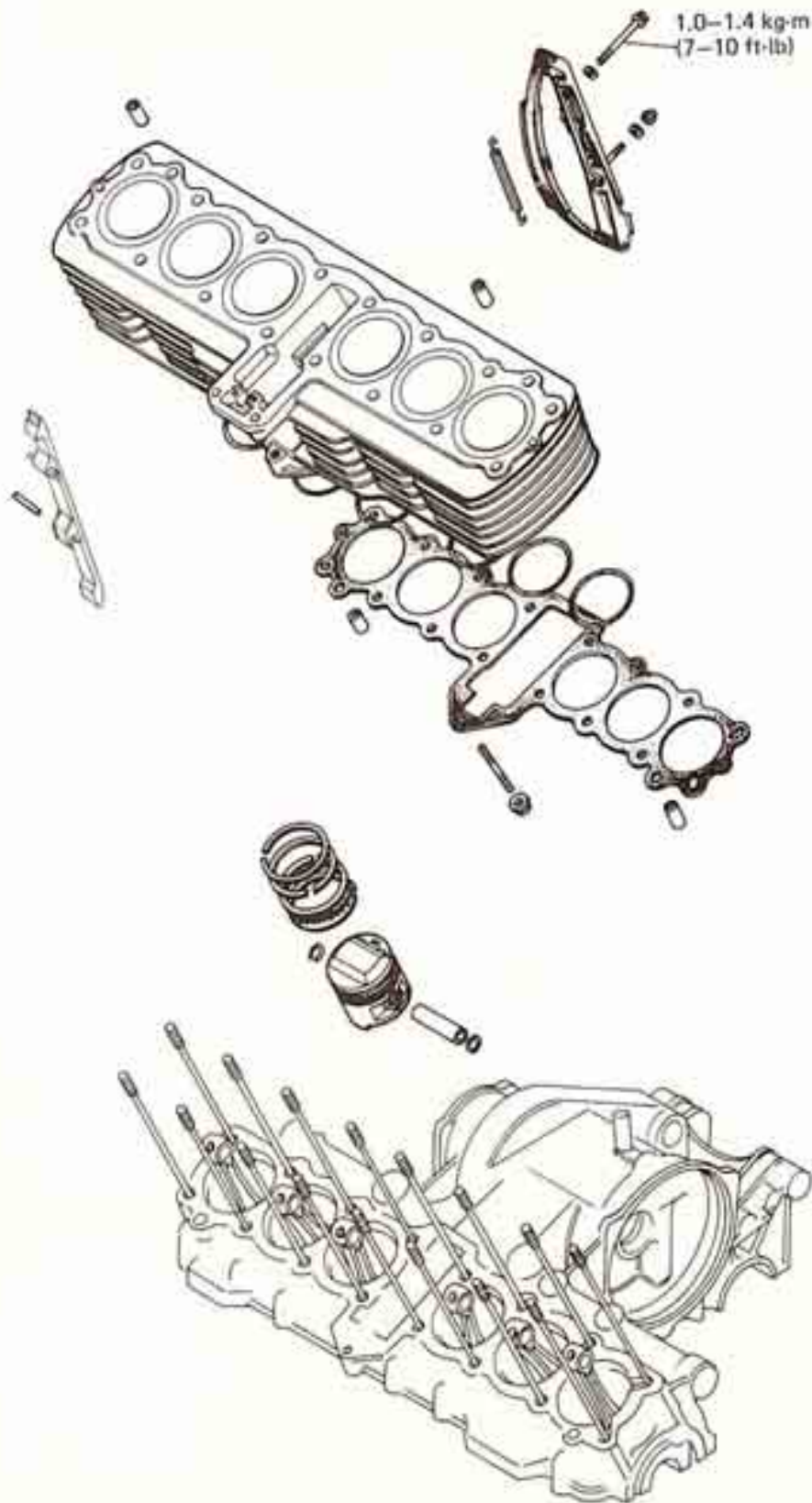





SERVICE INFORMATION	7-1	PISTON REMOVAL	7-3
TROUBLESHOOTING	7-1	PISTON INSTALLATION	7-7
CYLINDER REMOVAL	7-2	CYLINDER INSTALLATION	7-7

## SERVICE INFORMATION

### WORKING PRACTICE

All cylinder/piston maintenance and inspection can be accomplished with the engine in the frame.

### SPECIAL TOOLS

#### Special Tools

- Piston Base (4 required) 07958-2500000
- Piston Ring Compressor (4 required) 07954-4220000

### SPECIFICATIONS

			STANDARD	SERVICE LIMIT
Cylinder	I.D.		64.500-64.510 mm (2.5394-2.5398 in)	64.60 mm (2.543 in)
	Warpage		—————	0.10 mm (0.004 in)
Piston, piston rings and piston pin	Piston ring-to-ring groove clearance	TOP	0.015-0.045 mm (0.0006-0.0018 in)	0.09 mm (0.004 in)
		SECOND	0.015-0.045 mm (0.0006-0.0018 in)	0.09 mm (0.004 in)
	Ring end gap	TOP	0.15-0.30 mm (0.006-0.012 in)	0.5 mm (0.02 in)
		SECOND	0.15-0.30 mm (0.006-0.012 in)	0.5 mm (0.02 in)
		OIL (SIDE RAIL)	0.3-0.9 mm (0.012-0.035 in)	1.1 mm (0.04 in)
	Piston O.D.		64.47-64.49 mm (2.538-2.539 in)	64.40 mm (2.535 in)
	Piston pin bore		15.002-15.008 mm (0.5906-0.5909 in)	15.04 mm (0.592 in)
	Connecting rod small end I.D.		15.016-15.034 mm (0.5912-0.5919 in)	15.05 mm (0.592 in)
	Piston pin O.D.		14.994-15.000 mm (0.5903-0.5906 in)	14.98 mm (0.590 in)
	Piston-to-piston pin clearance		—————	0.04 mm (0.002 in)
Cylinder-to-piston clearance		—————	0.10 mm (0.004 in)	

## TROUBLESHOOTING

### Compression Too Low or Unstable

1. Worn cylinder or piston rings

### Excessive Smoke

1. Worn cylinder or piston
2. Improper installation of piston rings
3. Scored or scratched piston or cylinder

### Overheating

1. Excessive carbon build-up on the piston or combustion chamber.

### Knocking or Abnormal Noise

1. Worn piston and cylinder
2. Excessive carbon build-up



**CYLINDER/PISTON**

**CYLINDER REMOVAL**

Remove the cylinder head (Section 6).  
Remove the nut at the lower front cylinder base.  
Remove the cylinder.  
Remove the cam chain tensioner.



Remove the cylinder gasket and dowel pins.  
Remove the cam chain guide pin.

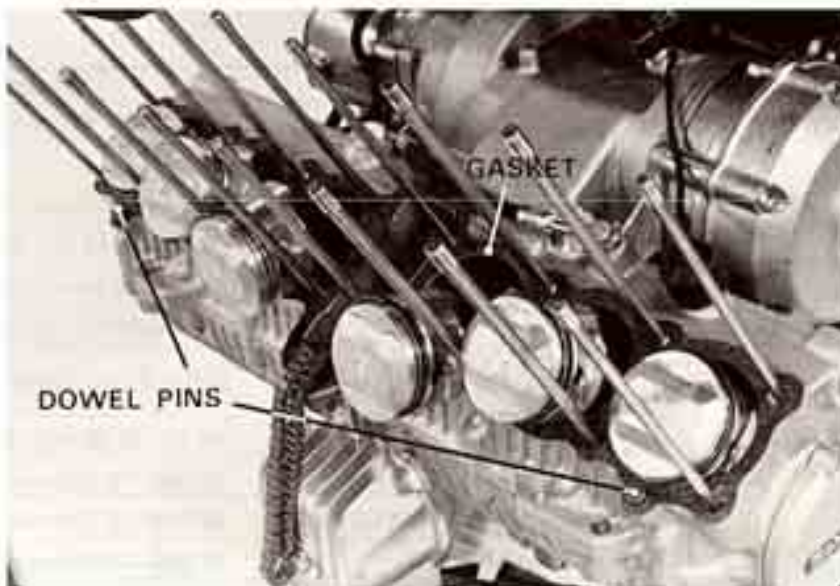

**CYLINDER INSPECTION**

Inspect the cylinder bores for wear or damage.  
Measure the cylinder I. D. at three levels in X and Y axis.

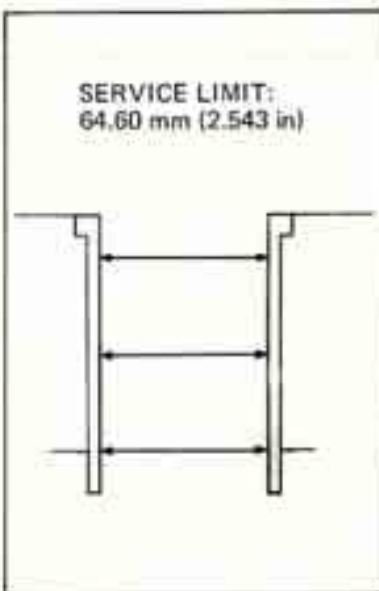





Inspect the top of the cylinders for warpage.  
Check in an X pattern as shown.



### CAM CHAIN TENSIONER INSPECTION

Inspect the slipper of the cam chain tensioner for damage or excessive wear.  
Inspect the tension spring for weakness.



### PISTON REMOVAL

Remove each piston pin clip with pliers.

#### NOTE

Do not allow clips to fall into the crankcase.

Press the piston pin out of the piston.

#### NOTE

Mark the pistons to indicate the cylinder positions.

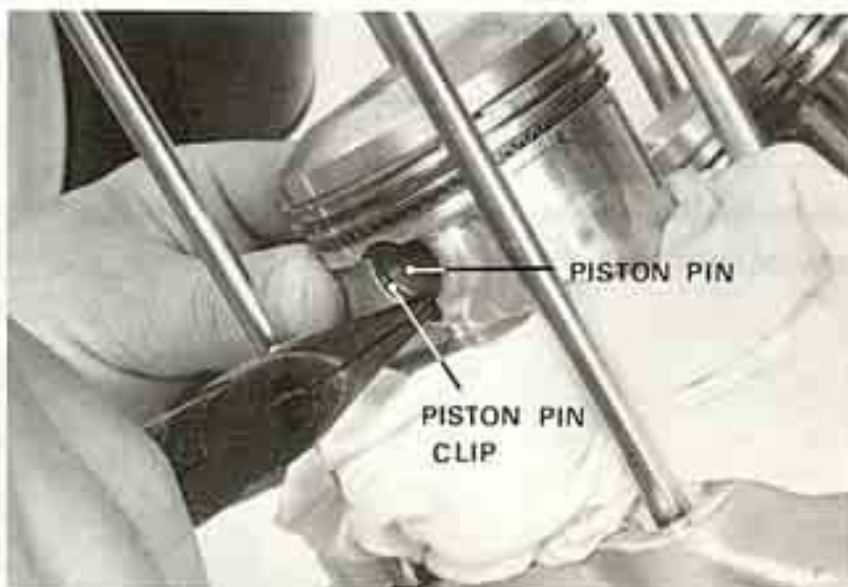



**CYLINDER/PISTON**

**PISTON/PISTON RING INSPECTION**

Inspect the piston ring-to-groove clearance.  
Remove the piston rings.

**NOTE**

Mark the rings so that they can be returned to their original locations.

Inspect the pistons for damage and cracks; ring grooves for wear.



**SERVICE LIMIT:**  
**TOP: 0.09 mm (0.004 in)**  
**SECOND: 0.09 mm (0.004 in)**

Insert each piston ring into the cylinder and inspect the end gap.

**SERVICE LIMITS:**

**TOP: 0.5 mm (0.02 in)**  
**SECOND: 0.5 mm (0.02 in)**  
**OIL (Side rail): 1.1 mm (0.04 in)**

**STANDARD END GAPS:**

**TOP: 0.15–0.30 mm (0.006–0.012 in)**  
**SECOND: 0.15–0.30 mm (0.006–0.012 in)**  
**OIL (Side rail): 0.3–0.9 mm (0.012–0.035 in)**



Measure the piston O. D. at the skirt.

**NOTE**

Measurements should be taken 10 mm (0.4 in) from the bottom.

Calculate the cylinder-to-piston clearance.

**SERVICE LIMIT: 0.1 mm (0.004 in)**



**SERVICE LIMIT:**  
**64.40mm (2.535 in)**

10 mm (0.4 in)





Measure the piston pin hole I. D.,

**SERVICE LIMIT:**  
**15.04 mm (0.592 in)**



Measure the connecting rod small end I. D.,  
(See Section 12 for replacement procedure)

**SERVICE LIMIT:**  
**15.05 mm (0.593 in)**



Measure the piston pin O. D.,

Determine the piston-to-piston pin clearance,  
**SERVICE LIMIT: 0.04 mm (0.002 in)**

**SERVICE LIMIT:**  
**14.98 mm (0.590 in)**





**CYLINDER/PISTON**

**PISTON RING INSTALLATION**

Install the piston rings.

**NOTE**

- Avoid piston and piston ring damage during installation.
- All rings should be installed with the markings facing up.
- After installation, the rings should rotate freely.

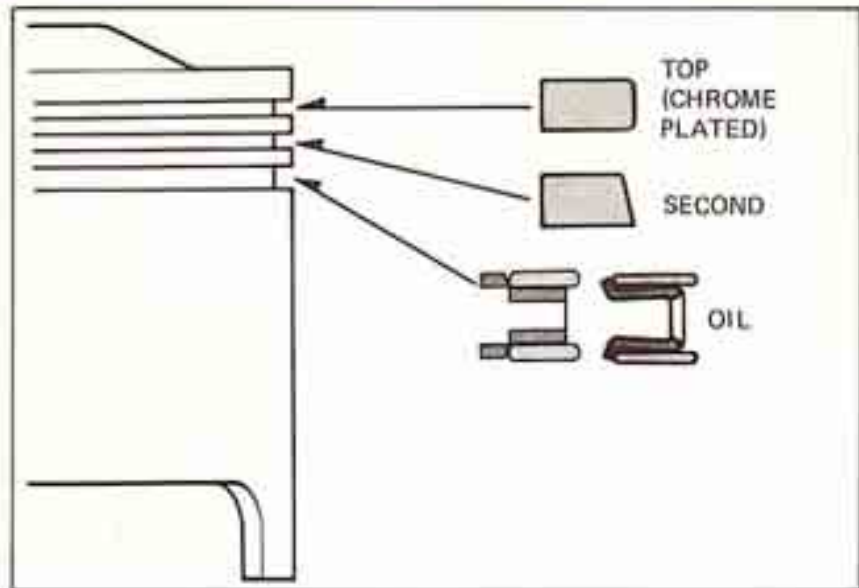

Space the piston ring end gaps 120 degrees apart.  
Do not align the gaps in the oil rings.

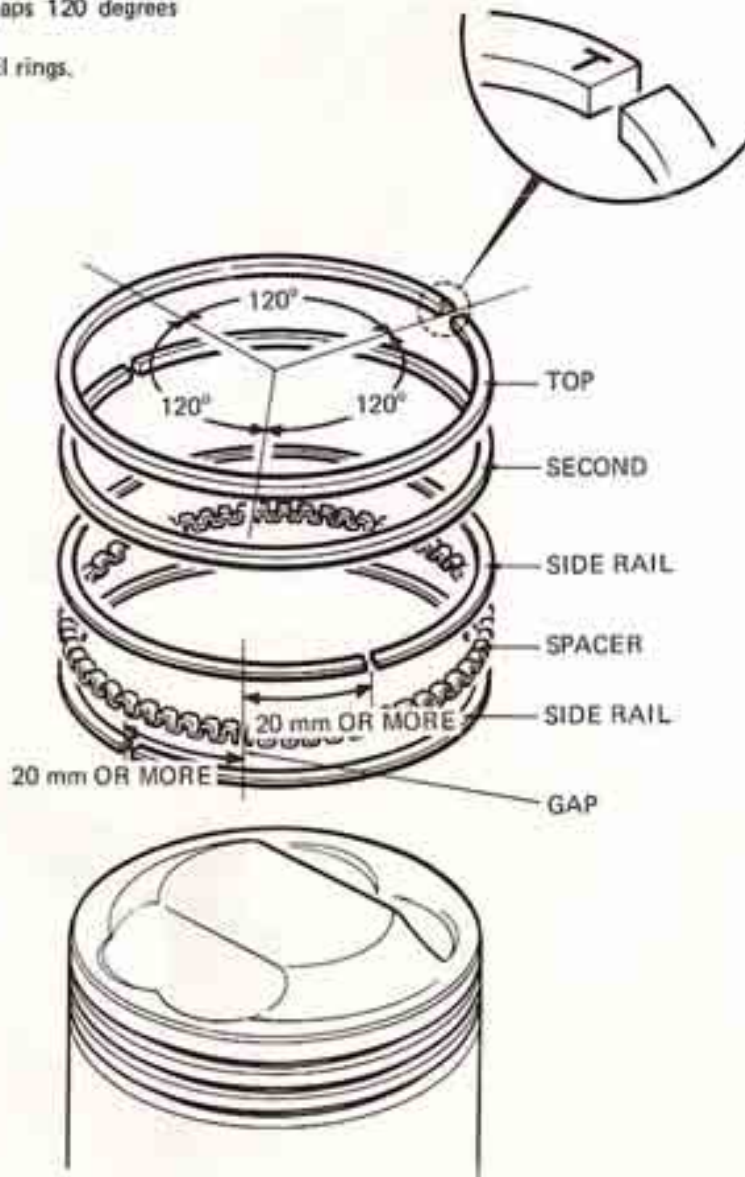





### PISTON INSTALLATION

Apply molybdenum disulfide grease to the connecting rod small ends.  
Install the pistons, piston pins and clips.

#### NOTE

- Position the mark "IN" on the piston to the intake side.
- Install the pistons in their original positions.
- Do not allow clips to fall into the crankcase.
- Do not damage the piston by fitting the cylinder edge.

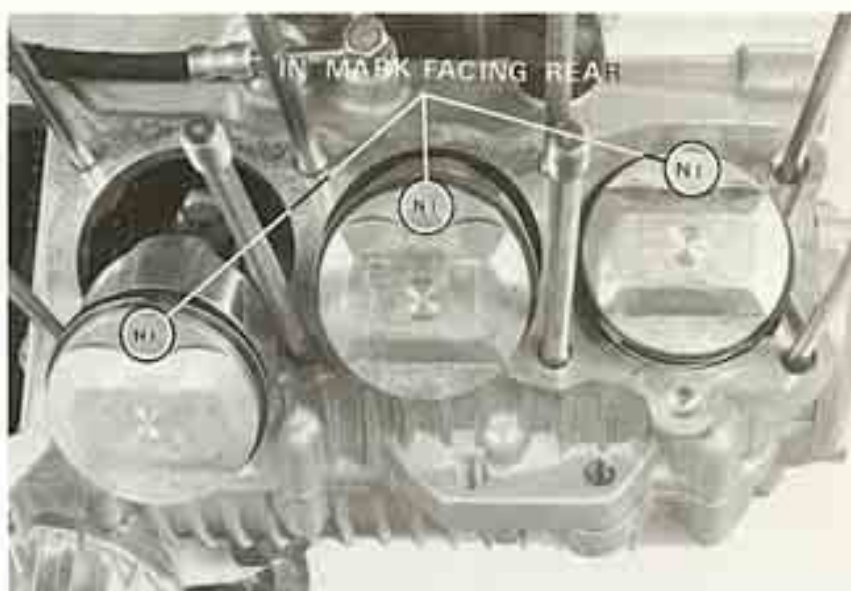

### CYLINDER INSTALLATION

Install the cam chain guide pin.



Install the cam chain tensioner.





**CYLINDER/PISTON**

Install the dowel pins and cylinder gasket.

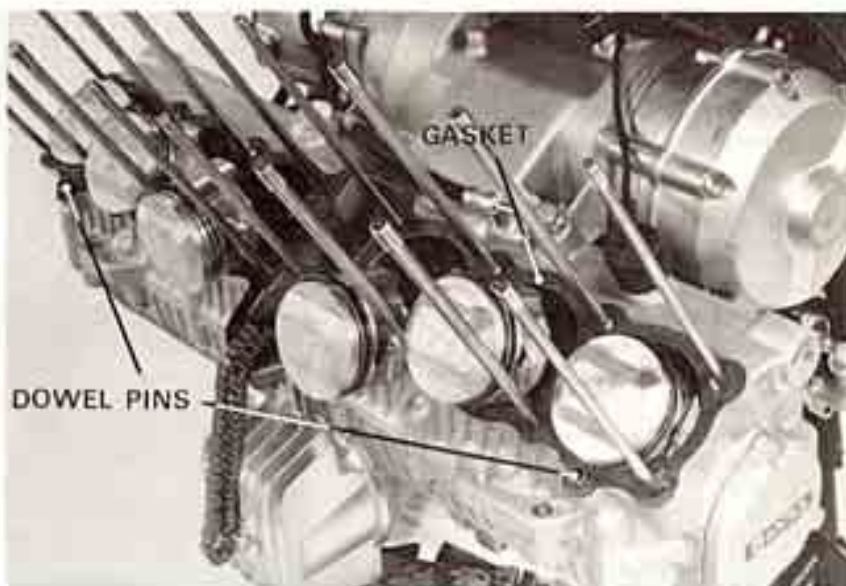

Install the cylinder.

**CAUTION**

*Avoid damaging the pistons and piston rings when installing the cylinder.*

**NOTE**

Before using the special tools, position the No. 2 and No. 5 pistons at T. D. C. (Top Dead Center).

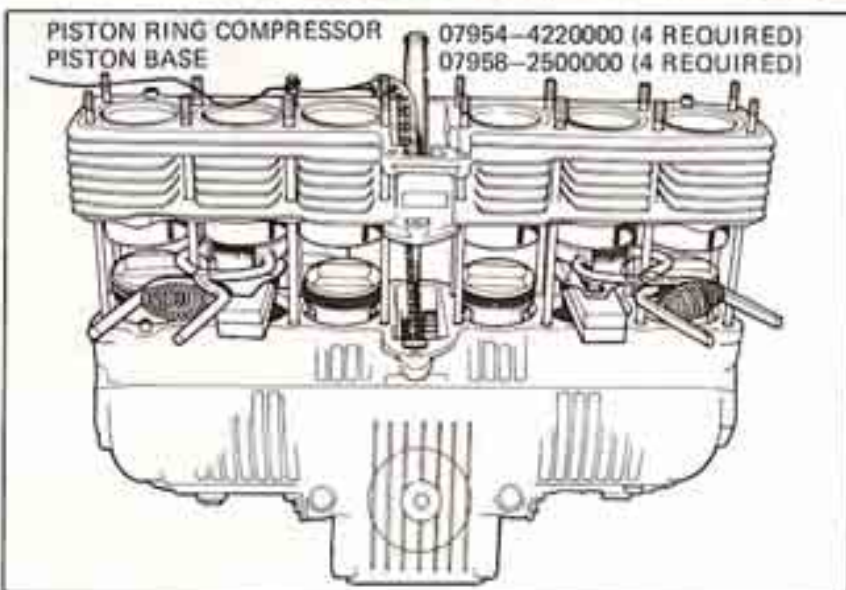

Tighten the cylinder base nut securely after installation.

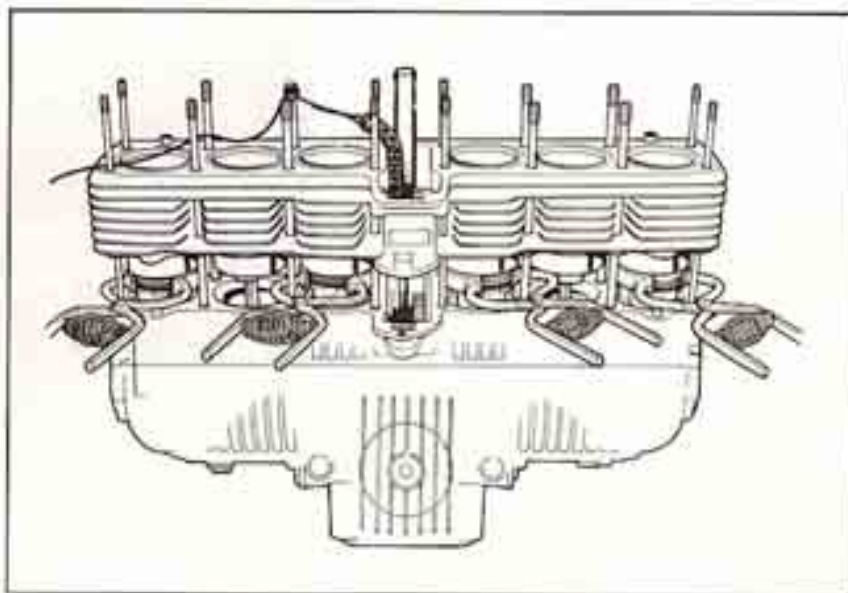



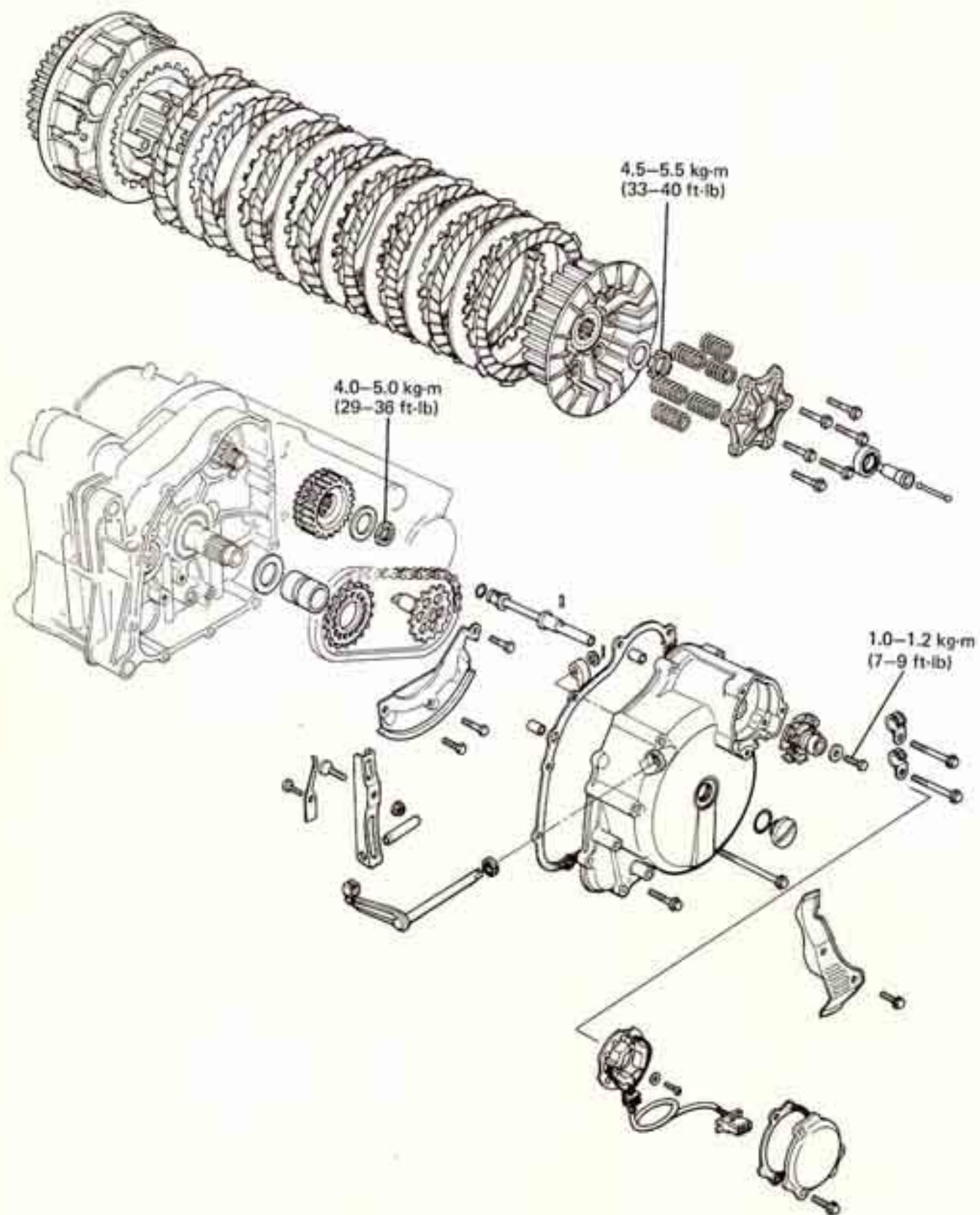



SERVICE INFORMATION	8-1	CLUTCH REMOVAL	8-3
TROUBLESHOOTING	8-1	CLUTCH INSTALLATION	8-8
CLUTCH COVER REMOVAL	8-2	CLUTCH COVER INSTALLATION	8-12

## SERVICE INFORMATION

### WORKING PRACTICE

This section covers removal and installation of the clutch, pulser generator and advancer, starting with the clutch cover. This operation can be accomplished with the engine in the frame.

### SPECIAL TOOLS

#### Common Tools

Universal Holder	07725-0010101
Handle	07716-0020500

#### Special Tools

Lock Nut Wrench	07916-4220000
Primary Gear Holder	07924-4220000

### TORQUE VALUES

Clutch lock nut	4.5-5.5 kg-m (33-40 ft-lb)	Spark advancer	1.0-1.2 kg-m (7-9 ft-lb)
Primary drive gear lock nut	4.0-5.0 kg-m (30-36 ft-lb)		

### SPECIFICATIONS

		STANDARD	SERVICE LIMIT	
Clutch	Lever free play (at lever end)	10-20 mm (3/8-3/4 in)	—	
	Spring free length	35.1 mm (1.38 in)	33.6 mm (1.32 in)	
	Spring preload/length	18.3-20.1 kg/24.4-25.6 mm (40.34-44.31 lbs/0.96-1.01 in)	17.0 kg/24.4-25.6 mm (37.48 lbs/0.96-1.01 in)	
	Disc thickness	A	3.42-3.58 mm (0.135-0.141 in)	3.1 mm (0.12 in)
		B	3.42-3.58 mm (0.135-0.141 in)	3.1 mm (0.12 in)
	Plate warpage	—	0.2 mm (0.01 in)	
	Clutch outer I.D.	37.000-37.025 mm (1.4567-1.4577 in)	37.06 mm (1.459 in)	
Clutch outer guide O. D.	36.950-36.975 mm (1.4547-1.4557 in)	36.93 mm (1.454 in)		
Oil pump drive system	Drive sprocket I.D.	37.000-37.021 mm (1.4567-1.4575 in)	37.1 mm (1.46 in)	
	Driven sprocket shaft O.D.	12.966-12.984 mm (0.5105-0.5112 in)	12.9 mm (0.51 in)	
Ignition timing	Refer to Section 3.			

## TROUBLESHOOTING

### Clutch

Faulty clutch operation can usually be corrected by adjusting the free play.

#### Clutch Slips When Accelerating

1. No free play
2. Discs worn
3. Springs weak

#### Clutch Will Not Disengage

1. Too much free play
2. Plates warped

#### Motorcycle Creeps With Clutch Disengaged

1. Too much free play
2. Plates warped

#### Excessive Lever Pressure

1. Clutch cable kinked, damaged or dirty
2. Lifter mechanism damaged

#### Clutch Operation Feels Rough

1. Outer drum slots rough





## CLUTCH COVER REMOVAL

Remove the exhaust pipes.  
Remove the oil hose cover.



### NOTE

The clutch cover can be removed without removing the pulser generator and advancer. The pulser generator and advancer removal is shown here. If removal is unnecessary, the clutch cover can be removed by removing the cover bolts.

Remove the pulser cover.  
Loosen the center bolt and three screws.  
Then, remove the pulser generator.

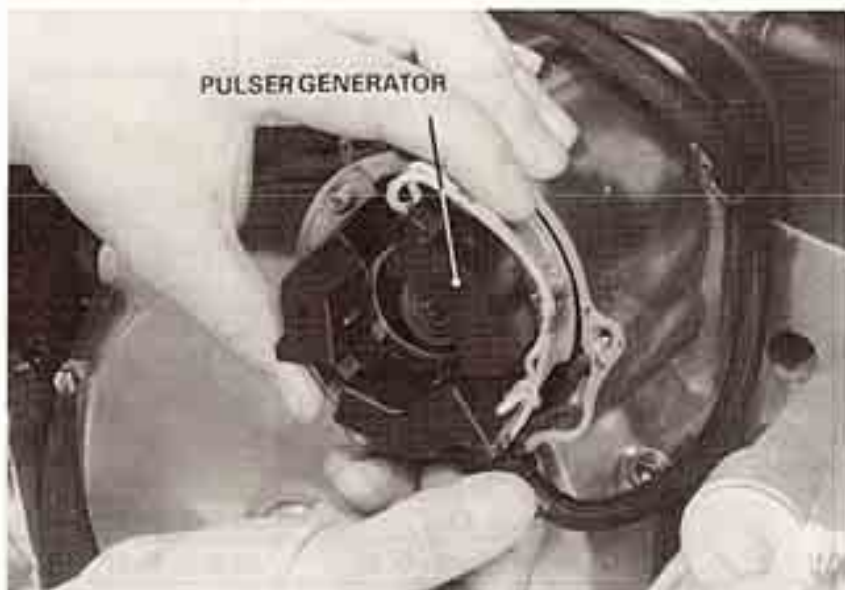

Remove the spark advancer unit.





Remove the clutch cover.  
Remove the advancer shaft.  
Remove the gasket and dowel pins.

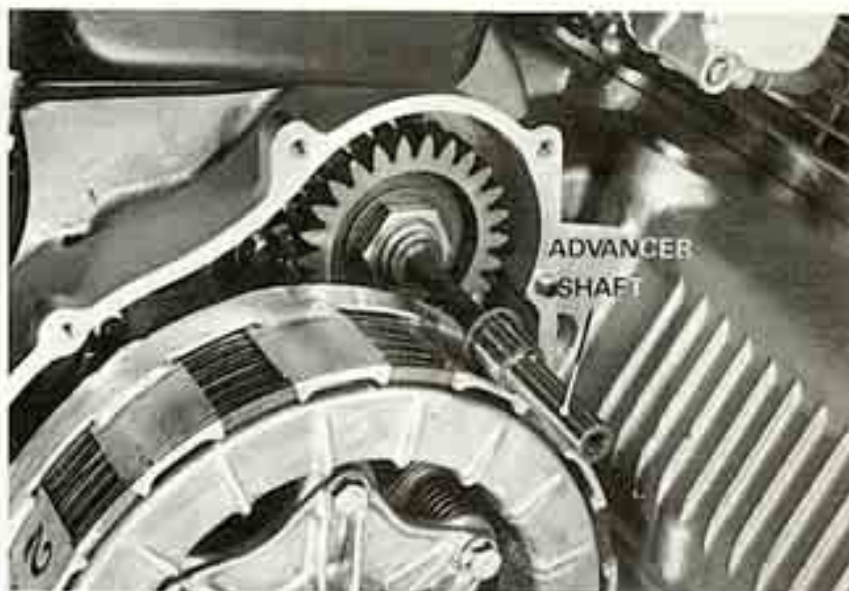

## CLUTCH REMOVAL

### CLUTCH LIFTER REMOVAL

Remove the clutch lifter shaft and adjusting arm.

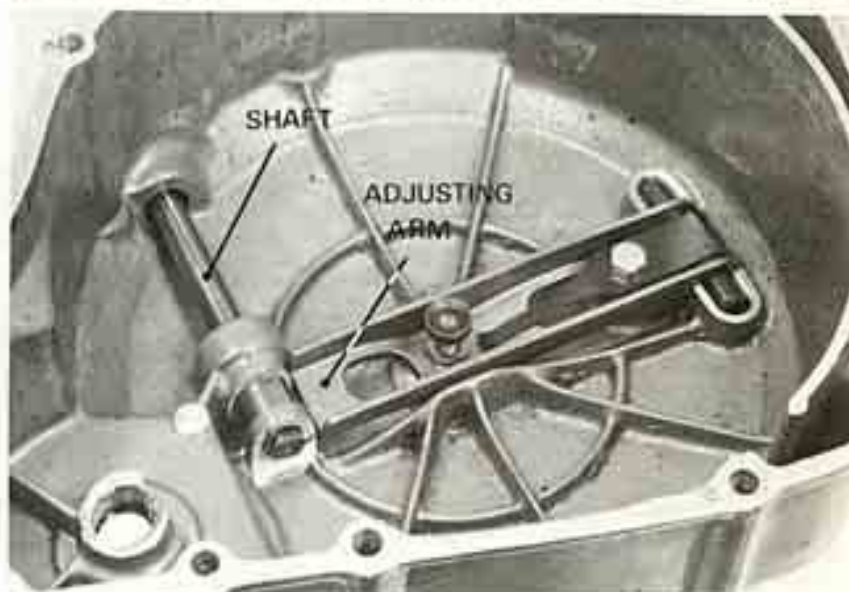

### CLUTCH REMOVAL

Use the universal holder if the drive chain is removed.  
Shift the transmission into gear to lock the countershaft and mainshaft.  
Block the drive sprocket to prevent it from turning.

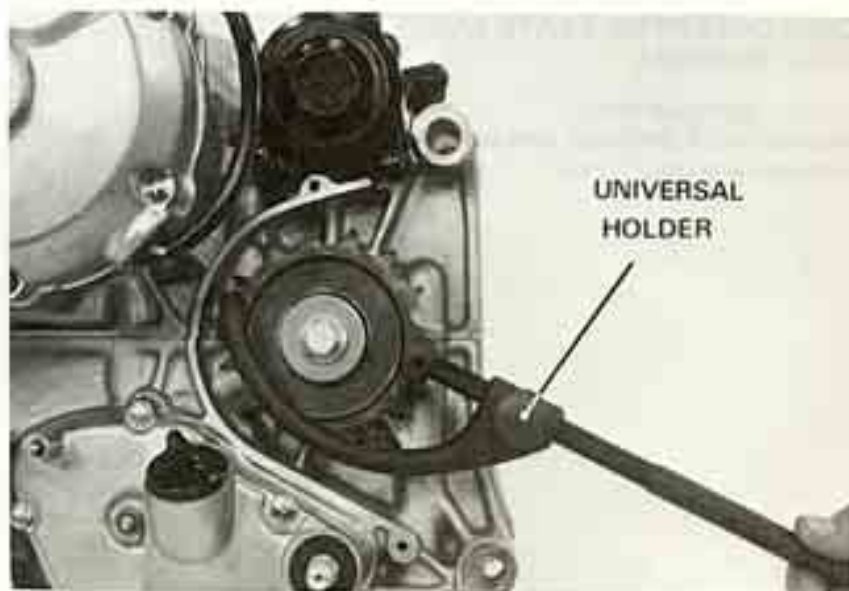





**CLUTCH**

When servicing the clutch with the engine in the frame, shift the transmission into gear and press the brake pedal to lock the transmission.

Remove the clutch lifter guide.  
Remove the release bearing.

Attach the lock nut wrench.  
Remove the lock nut and washer.  
The clutch can now be removed out as a unit.

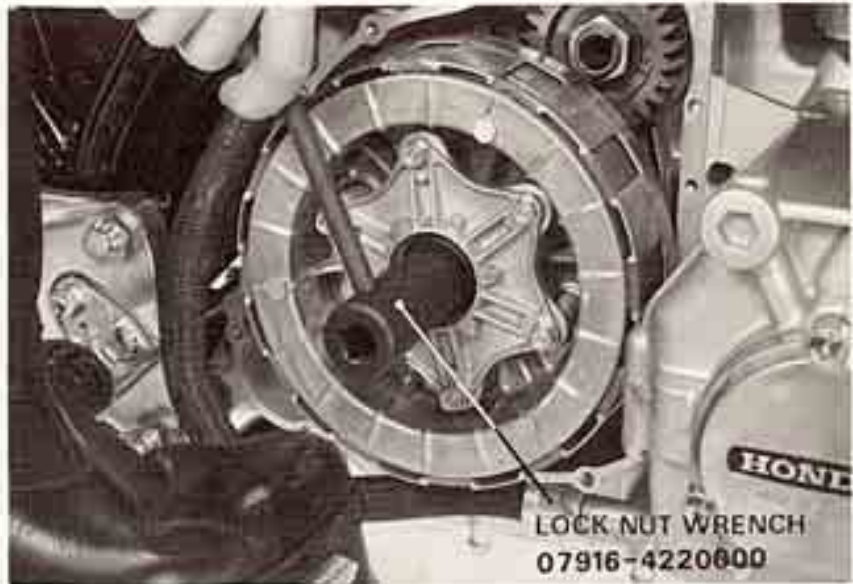

**CLUTCH LIFTER PLATE  
REMOVAL**

Remove the bolts, lifter plate and clutch springs.

**NOTE**

Loosen the bolts in a crisscross pattern in 2-3 steps.



**CLUTCH CENTER, PLATE AND  
DISC REMOVAL**

Remove the clutch center.  
Remove discs A and B and plate A.  
Remove the pressure plate.

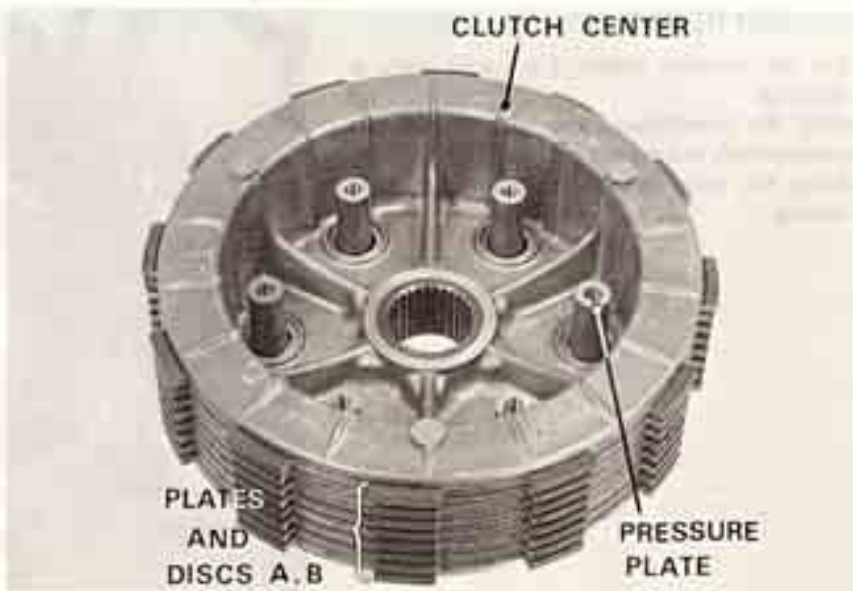



**CLUTCH SPRING INSPECTION**

Measure the clutch spring free length.

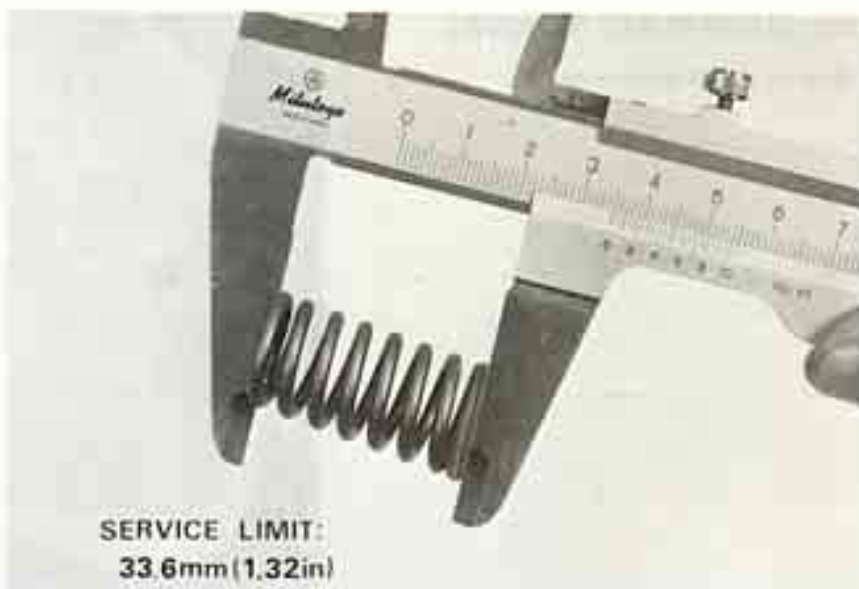

**CLUTCH DISC INSPECTION**

Replace the clutch discs if they show signs of scoring or discoloration.  
Measure disc thickness.



**PLATE INSPECTION**

Check for plate warpage on a surface plate.

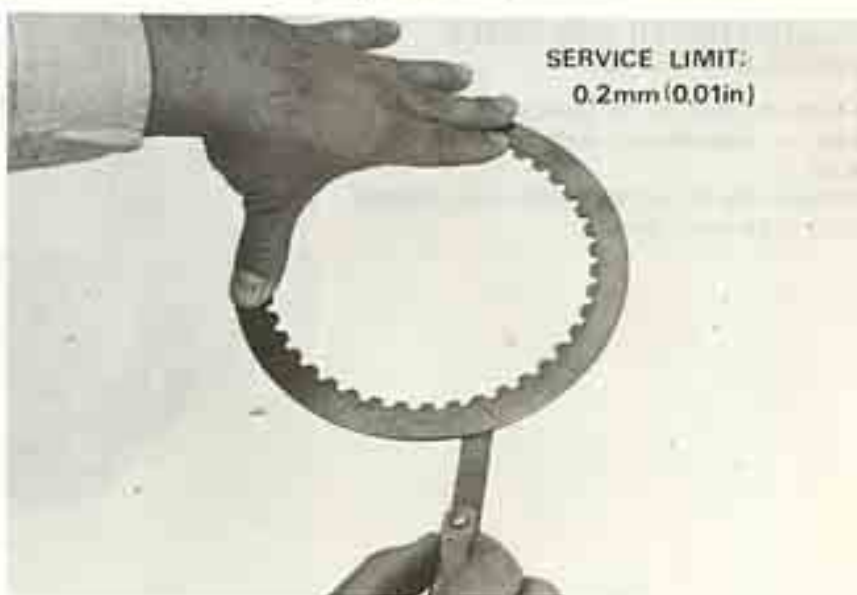





**CLUTCH**

**OIL GUIDE PLATE REMOVAL**

Remove the oil guide plate.

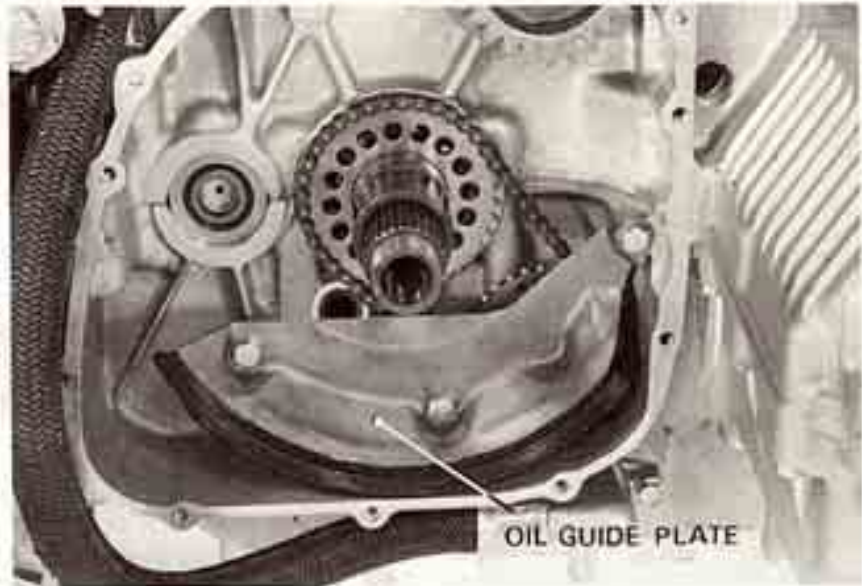

**OIL PUMP SPROCKETS AND CLUTCH OUTER GUIDE REMOVAL**

Remove the oil pump drive and driven sprockets and clutch outer guide.



**CLUTCH OUTER AND OUTER GUIDE INSPECTION**

Check the slots in the outer drum for nicks, cuts or indentations made by the friction discs.

Measure the I.D. of the clutch outer and the O.D. of the outer guide.

**SERVICE LIMIT:**

**OUTER I.D. : 37.06mm (1.459in)**

**GUIDE O.D. : 36.93mm (1.454in)**





**OIL PUMP DRIVE SPROCKET AND  
DRIVEN SPROCKET MEASURE-  
MENT**

Measure the oil pump drive sprocket I.D..



Measure the oil pump driven sprocket shaft  
O.D..



**PRIMARY DRIVE GEAR  
REMOVAL**

Hold the primary drive gear with the primary  
gear holder as shown.  
Loosen the lock nut.

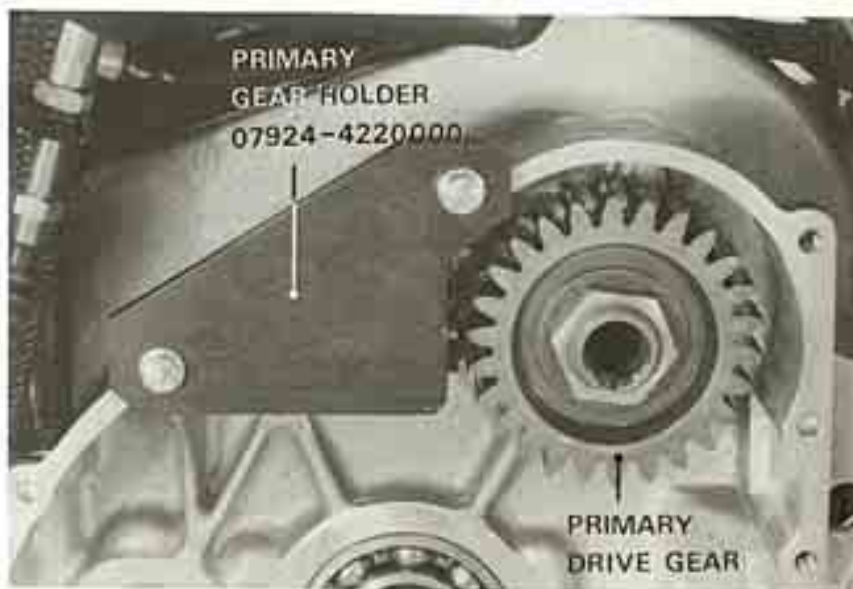





## CLUTCH INSTALLATION

Install the primary drive gear.

### NOTE

- Position the drive gear with the large gear facing out.
- Position the mark "OUTSIDE" on the lock washer on the outside.

Tighten the lock nut to the specified torque.

**TORQUE: 4.0–5.0 kg-m (29-36 ft-lb)**



Install the thrust washer and clutch outer guide on the transmission mainshaft.  
Install the oil pump drive sprocket, driven sprocket and drive chain.  
Align the driven sprocket key with the oil pump shaft slot.  
Install the oil guide plate.





Install the following parts in the clutch outer in the order listed.

- Pressure plate
- Discs A and plates A (7 each) alternately
- Disc B
- Clutch center
- Clutch springs
- Clutch lifter plate

### NOTE

Before installing the clutch, apply engine oil to the discs and plates.

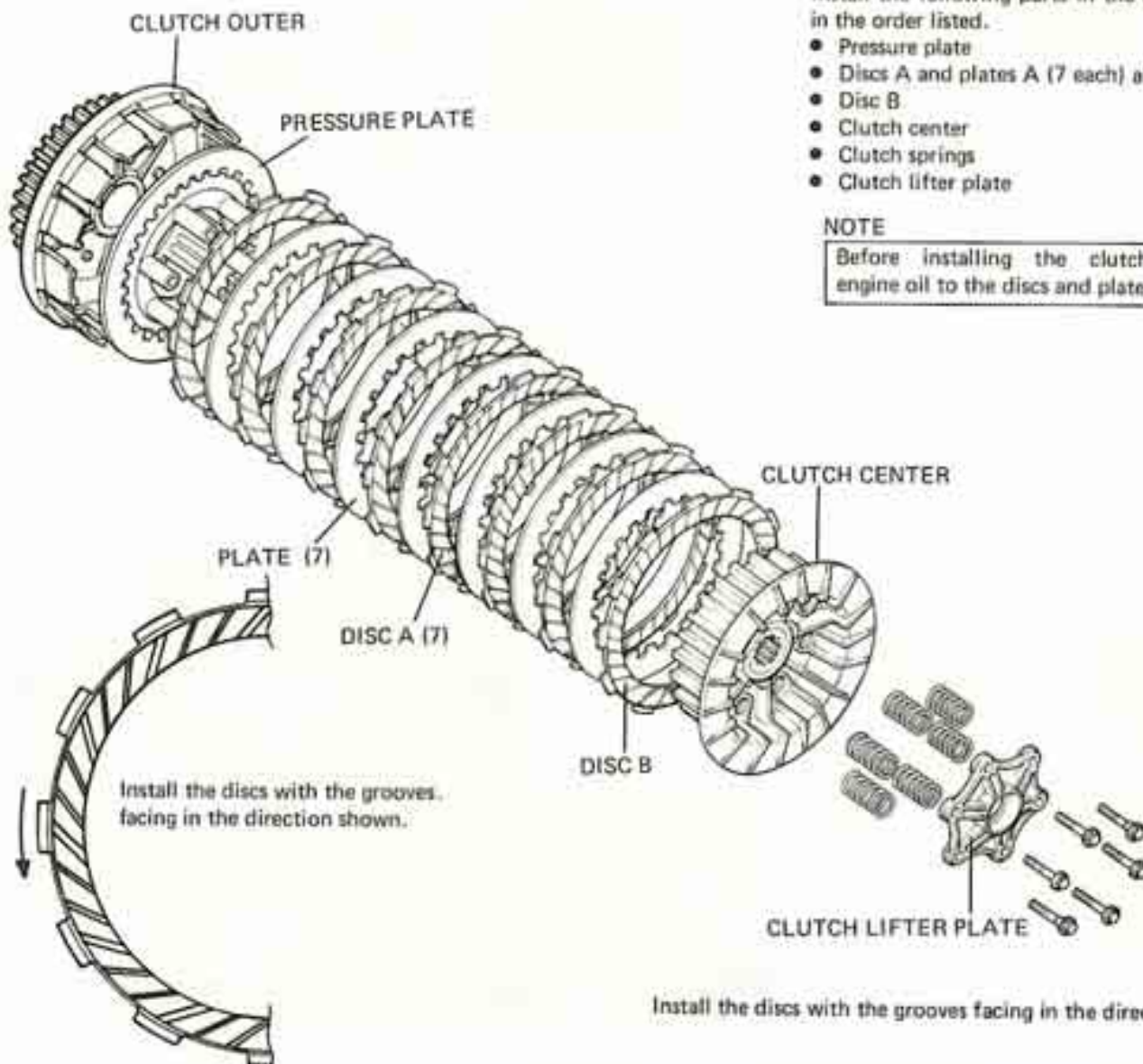

Install the discs with the grooves facing in the direction shown.

Align the splines by rotating the clutch center.  
Install the clutch springs, lifter plate and lifter plate bolts.

### NOTE

Tighten the bolts in two or more steps and in a criss cross pattern.







**CLUTCH**

**NOTE**

The lifter plate bolts are two diameters.

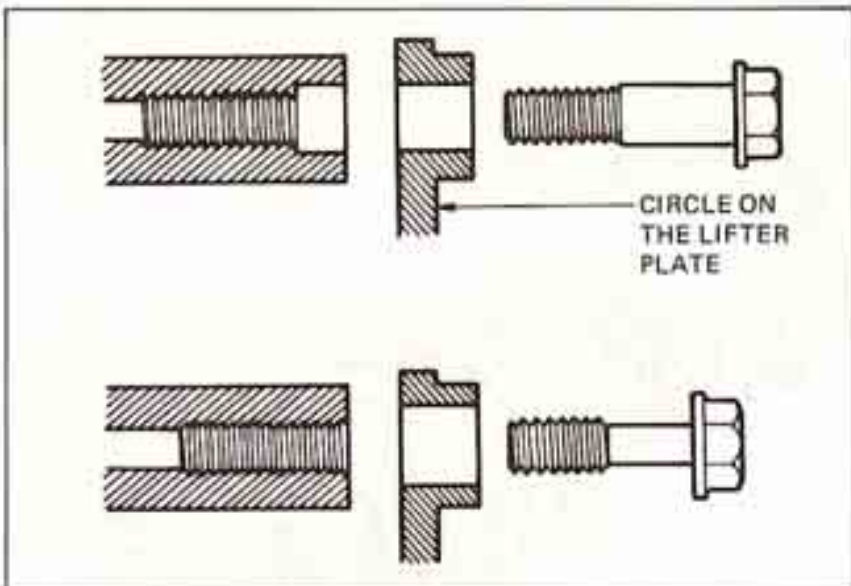

Turning the primary drive gear, find a pair of the outer and inner gear teeth which are aligned.

Assemble the clutch outer gear so it meshes with the aligned teeth and also connect the clutch outer to the oil pump drive sprocket by coupling the lugs and holes.

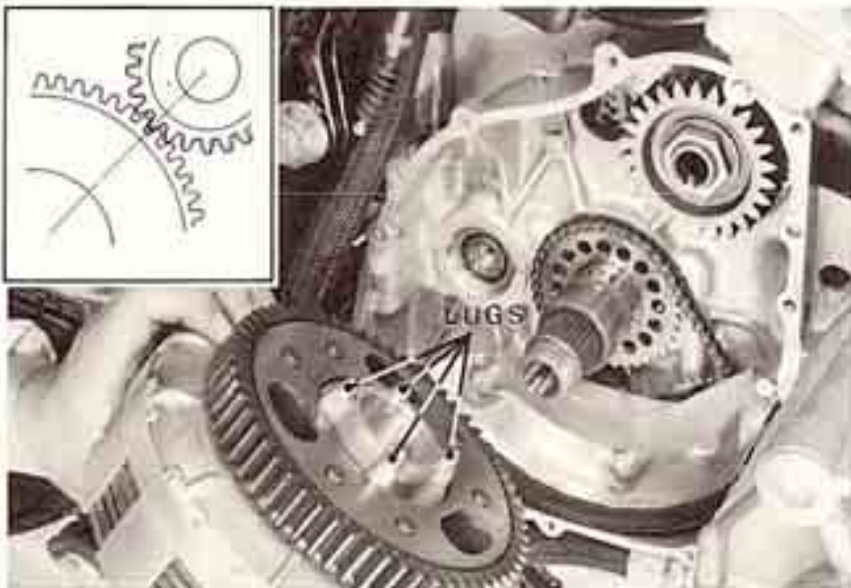

Install the lock washer and lock nut.

**NOTE**

Position the mark "OUTSIDE" on the lock washer facing out.





Tighten the lock nut to the specified torque.

**TORQUE: 4.5–5.5 kg-m (33–40 ft-lb)**

**NOTE**

With transmission engaged, depress the rear brake pedal to lock transmission.



Install the release bearing in the lifter plate.  
Insert the clutch lifter guide.  
Install the clutch lifter pin.

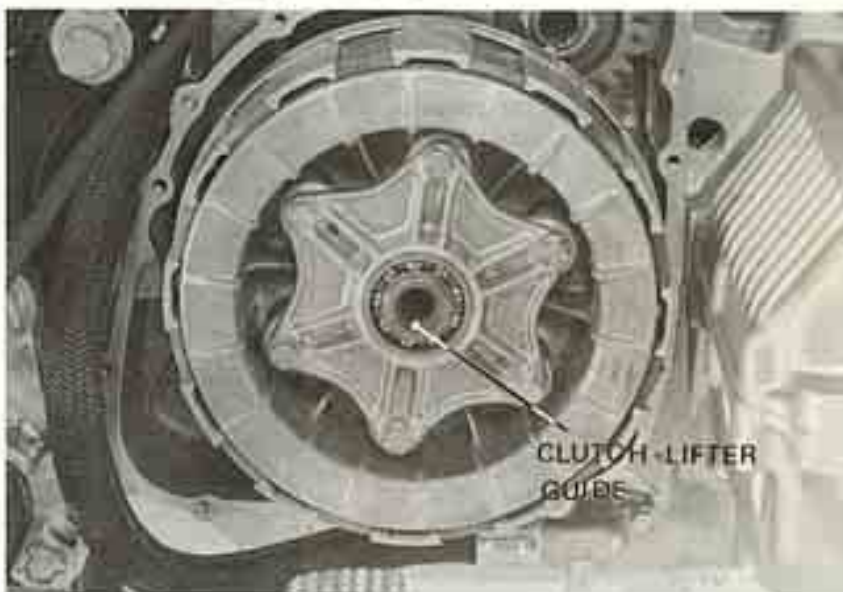

Install the advancer shaft.  
Make sure that the pin on the shaft is aligned  
with the slot in the primary shaft.







## CLUTCH COVER INSTALLATION

Coat the advancer shaft oil seal with oil.  
 Drive the oil seal with the proper rod until the top of the oil seal is flush with the advancer side surface of the clutch cover.



Install the clutch lifter cam and shaft.  
 Insert the cotter pin and spread the ends.

Apply molybdenum disulfide grease to the advancer shaft hole of the clutch cover.



Install the clutch adjusting arm and spring.  
 Install the dowel pins and gasket.  
 Install the clutch cover.

Adjust the clutch free play (Section 3).

Apply molybdenum disulfide grease to the clutch adjusting hole cap.





Install the advancer.  
Align the slot on the spark advancer unit with the pin on the advancer shaft.  
Tighten the advancer bolt.

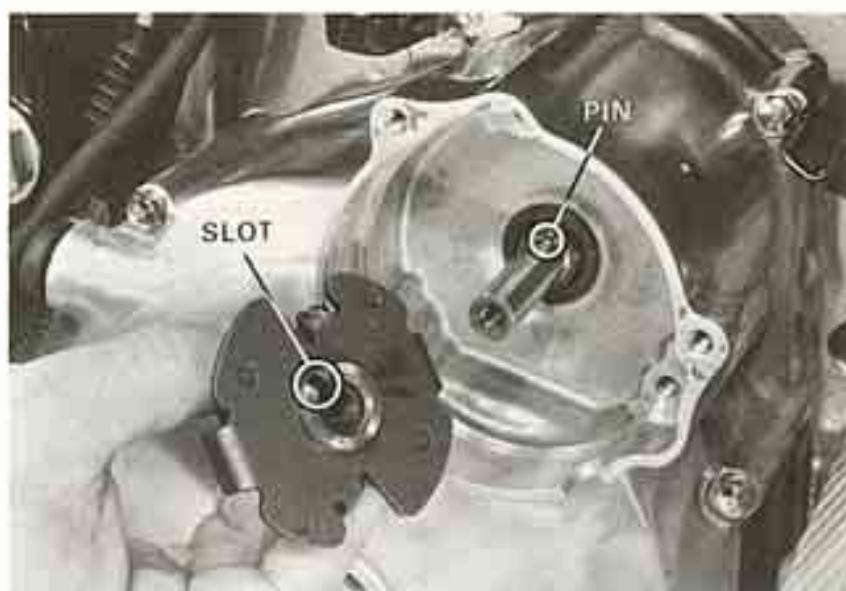

Install the pulser generator.  
Adjust the ignition timing, if necessary (Section 3).





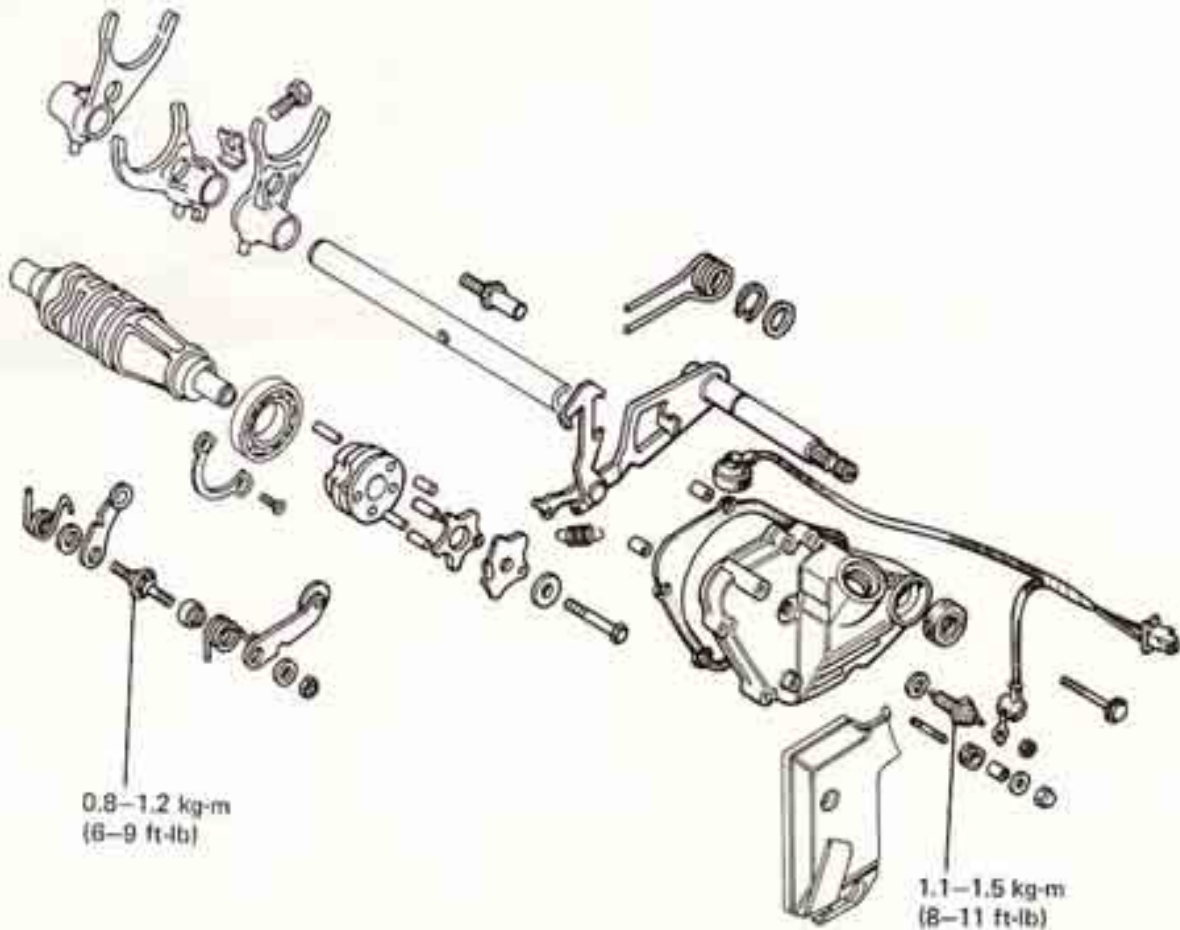
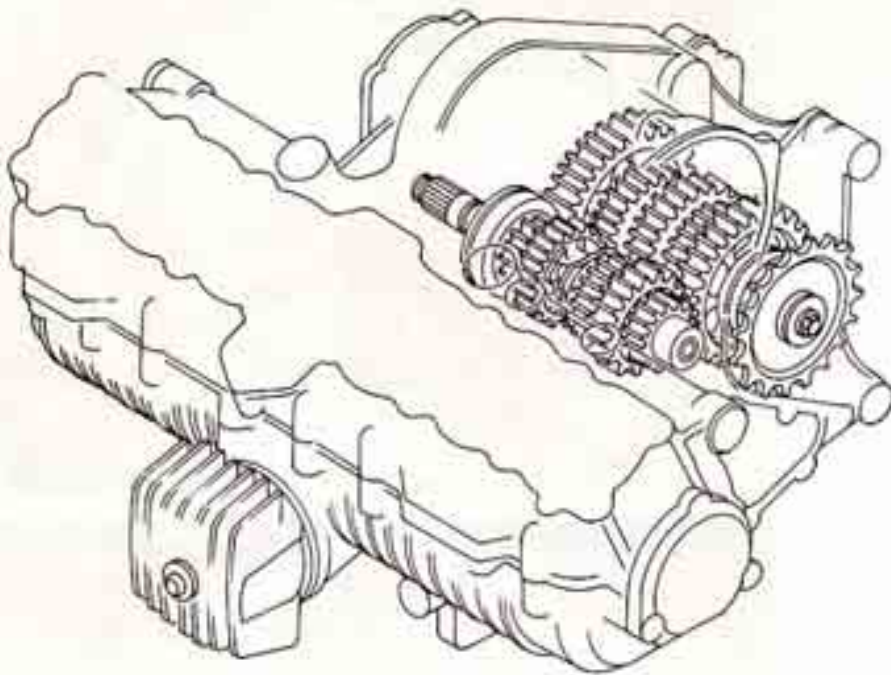



SERVICE INFORMATION	9-1
TROUBLESHOOTING	9-1
GEARSHIFT PEDAL AND LINKAGE REMOVAL	9-2
GEARSHIFT LINKAGE INSTALLATION	9-4
GEARSHIFT PEDAL INSTALLATION	9-6

## SERVICE INFORMATION

### WORKING PRACTICE

The gearshift spindle and stopper arms can be serviced with the engine in the frame. The outline of the shift forks and drum can be inspected by removing the oil pan. If the shift forks, drum and transmission requires servicing, remove the engine and separate the crankcases.

### TORQUE VALUES

Stopper arm shaft	0.8-1.2 kg-m (6- 9 ft-lb)
Neutral switch	1.1-1.5 kg-m (8-11 ft-lb)

## TROUBLESHOOTING

### Hard to Shift

1. Improper clutch adjustment; too much free play
2. Shift forks bent
3. Shift shaft bent
4. Shift claw bent
5. Shift drum cam grooves damaged

### Transmission Jumps Out of Gear

1. Gear dogs worn
2. Shift shaft bent.
3. Shift drum stopper broken
4. Shift forks bent





## **GEAR SHIFT PEDAL AND LINKAGE REMOVAL**

Drain engine oil.

Remove the left exhaust pipes.

Remove the oil hose cover.

Remove the gear shift pedal linkage.



Remove the oil hose.



Disconnect the neutral switch lead.  
Remove the drive sprocket and gear shift linkage covers.  
Remove the gasket and dowel pins.

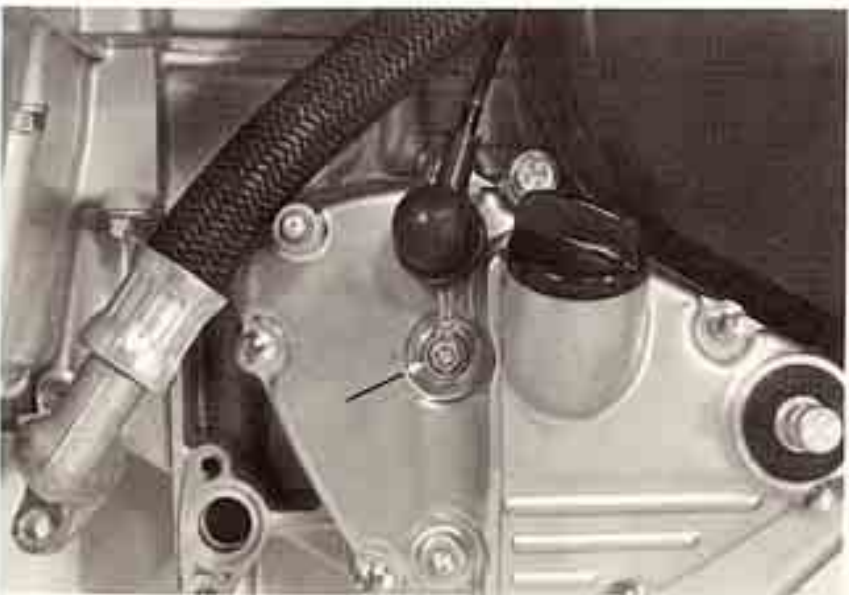



Remove the roller stopper plate bolt and plate.

Remove the drum stopper arm nut, arm and spring.



Remove the gear shift spindle assembly.  
Remove the drum stopper cam and drum stopper.

Loosen the stopper arm shaft.

Remove the neutral stopper arm and spring.

If bearing removal is necessary, remove the bearing stopper plate.

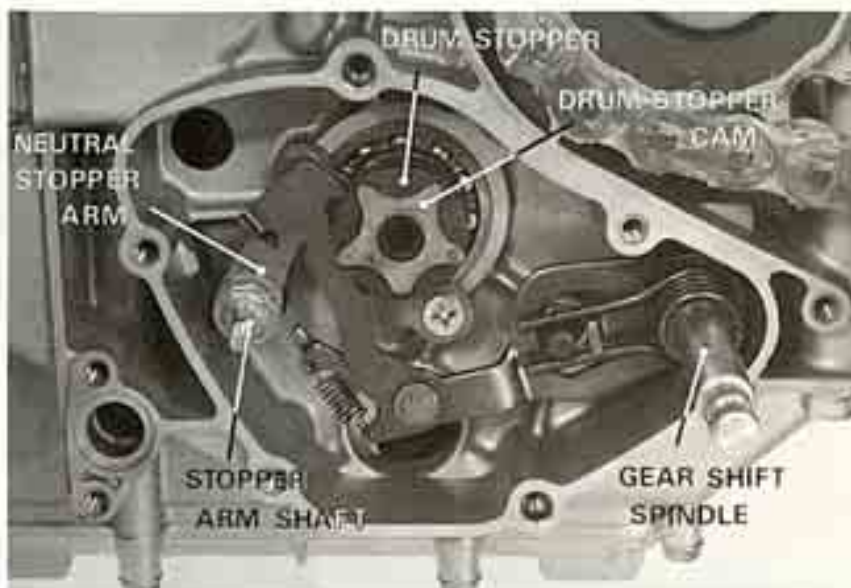

### NEUTRAL SWITCH INSPECTION

Check the switch operation.

Check the neutral switch for continuity between the top and bottom terminals.

The switch is normal if there is continuity.

Also check for shorts between the top terminal and any body ground.

Replace the switch if there is continuity.







## GEAR SHIFT LINKAGE INSTALLATION

Align the hole in the drum stopper with the pin on the shift drum.

### NOTE

If bearing replacement is necessary, apply locking agent to the threads of the screws.

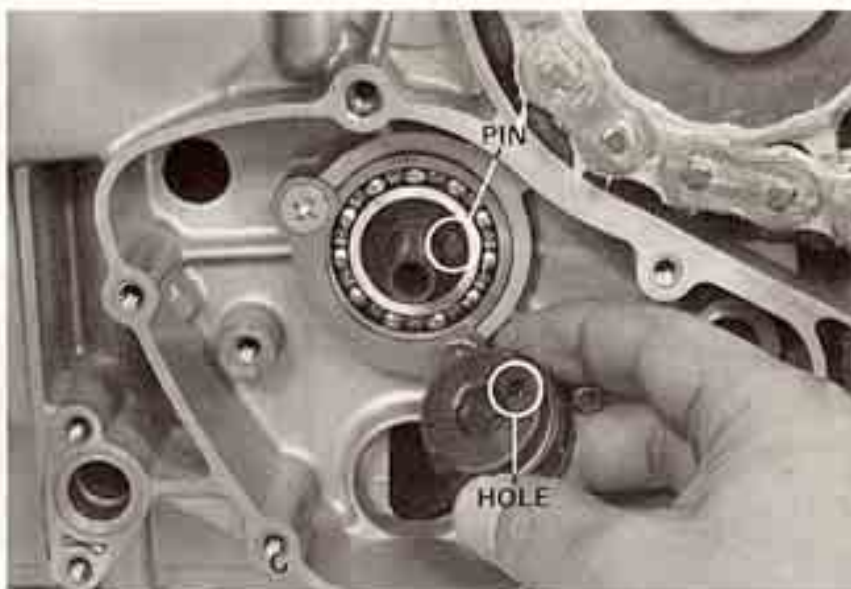

Install the stopper arm shaft, neutral stopper arm and return spring.

Make sure that the roller on the neutral stopper arm is positioned correctly in the groove.



Assemble the gear shift spindle, return spring and snap ring.

Install as shown.





Align the hole in the drum stopper cam with the pin on the drum stopper.

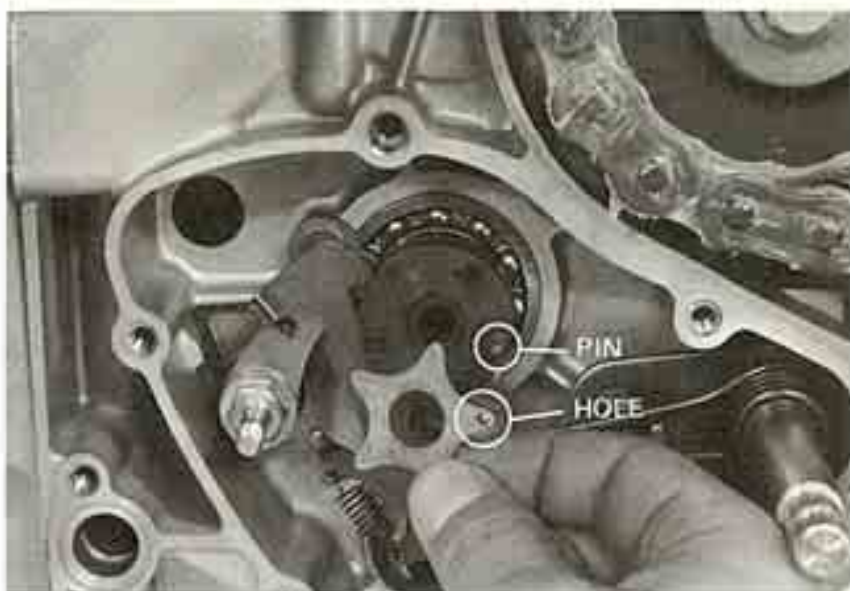

Install the drum stopper arm and return spring.



Align the hole in the roller stopper plate with the pin on the drum stopper cam.

Apply a locking agent to the bolt.  
Tighten the stopper plate bolt securely.

Check the linkage for smooth operation by rotating the gear shift spindle.

Install the covers.  
Connect the neutral switch lead.

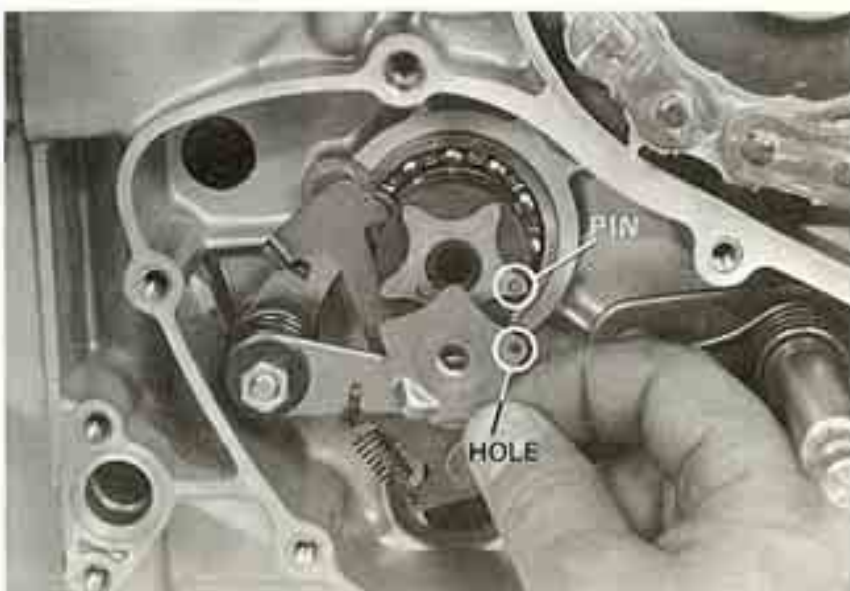





## GEAR SHIFT PEDAL INSTALLATION

Install the gear shift pedal as shown.

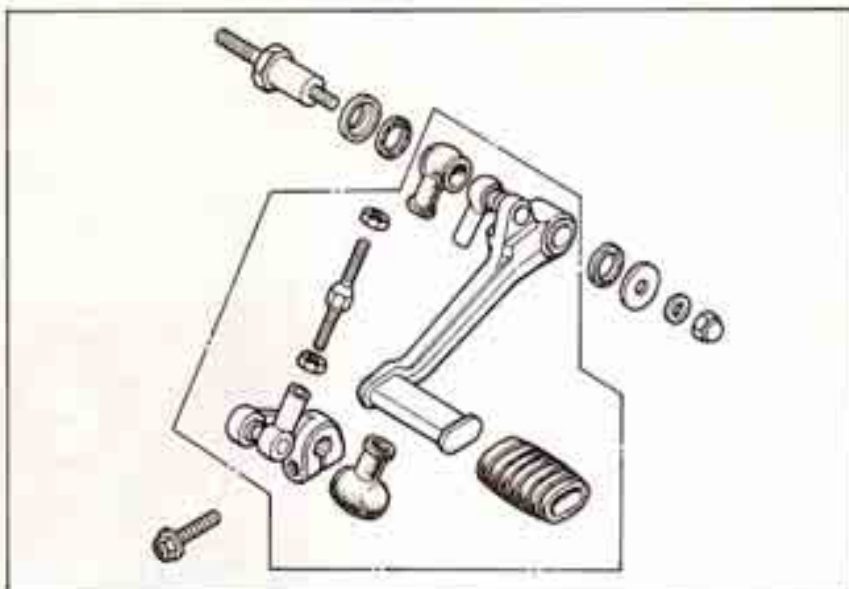

### NOTE

- Coat the dust seal with the oil.
- Align the punch mark on the joint arm with the punch mark on the gear shift spindle.
- Tighten the bolt and nut securely.

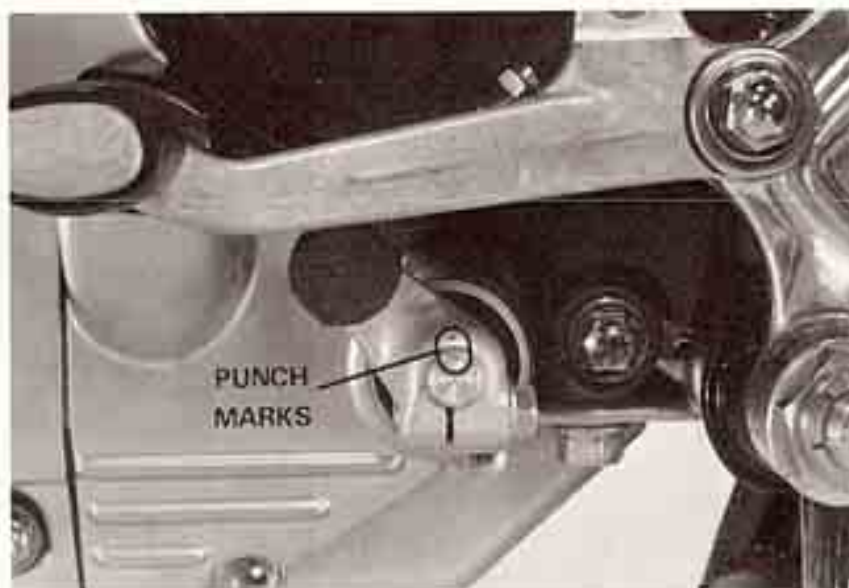

Adjust by turning the adjuster after loosening the lock nuts.  
Tighten the lock nuts.





**CRANKCASE**

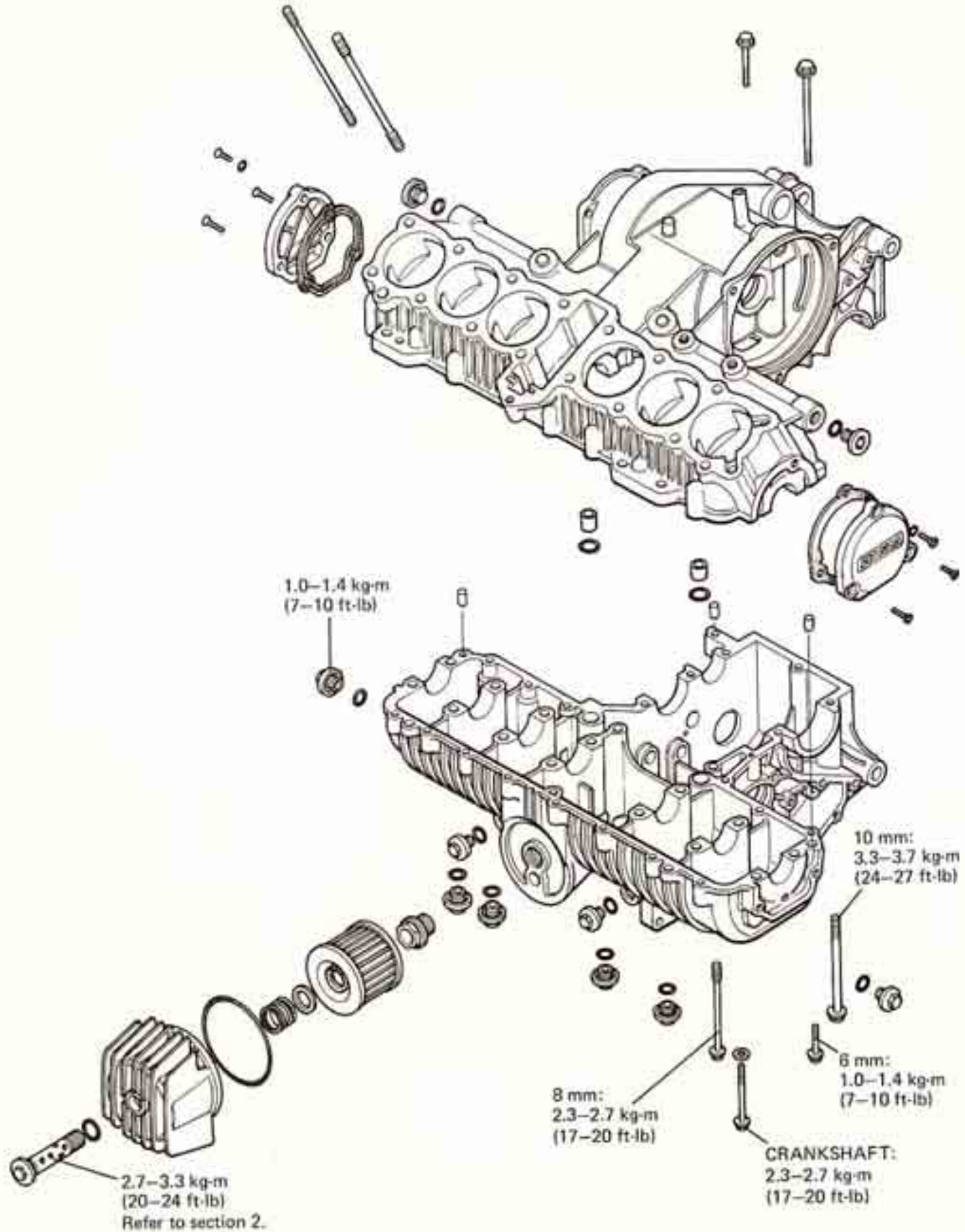





SERVICE INFORMATION	10-1
CRANKCASE DISASSEMBLY	10-2
CRANKCASE ASSEMBLY	10-4

## SERVICE INFORMATION

### WORKING PRACTICE

To repair the crankshaft, connecting rod, primary shaft and the transmission including the shift fork and drum, it is necessary to separate the crankcase halves.

The following parts must be removed before disassembling the crankcase.

Item to be serviced	Items to be removed
Crankshaft and connecting rod	Cylinder head, cylinder, pistons and primary shaft assembly
Primary shaft	A.C. generator and lock nut (inside the clutch)
Transmission	Clutch, oil pump drive chain and gear shift linkage

### TORQUE VALUES

8mm bolt (Crankshaft)	2.3-2.7 kg-m (17-20 ft-lb)
8mm bolt (Crankcase)	2.3-2.7 kg-m (17-20 ft-lb)
6mm bolt	1.0-1.4 kg-m ( 7-10 ft-lb)
10mm bolt	3.3-3.7 kg-m (24-27 ft-lb)
Oil path cap	1.0-1.4 kg-m ( 7-10 ft-lb)



**CRANKCASE**

**CRANKCASE DISASSEMBLY**

Remove the cylinder head, cylinder, pistons and oil filter (Sections 6 and 7).

Remove the clutch, clutch related parts, A. C. generator, gear shift linkage and starting motor (Sections 8, 9, 16 and 18).

**NOTE**

The crankcase can be separated without removing the clutch, clutch related parts, A. C. generator, gearshift mechanism and starting motor. However, we recommend removal of these parts, because the transmission gears may be dropped when separating the crankcase.

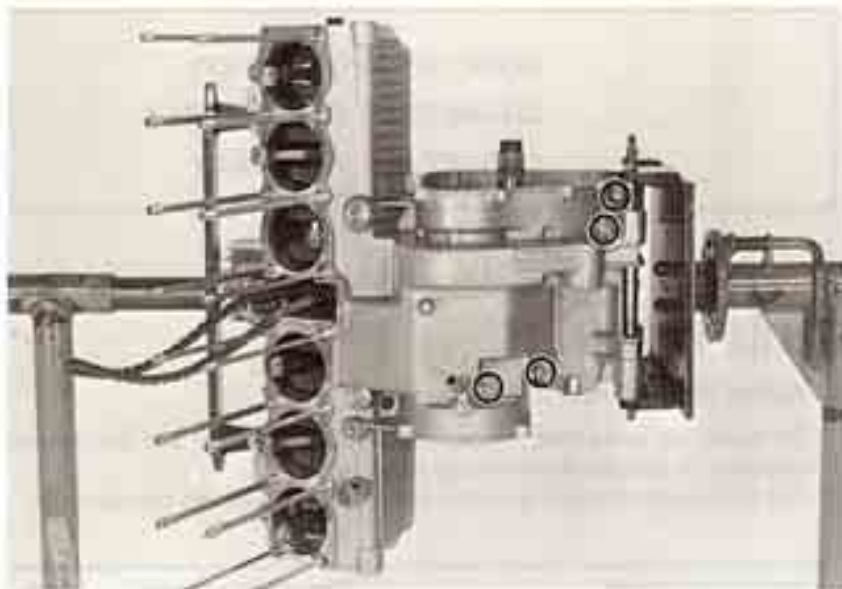

Remove the upper crankcase bolts.

Turn the engine upside down.

Remove the oil pan.

Remove the lower crankcase bolts.

**NOTE**

Remove the bolts in two or more steps and in a crisscross pattern to prevent warpage.

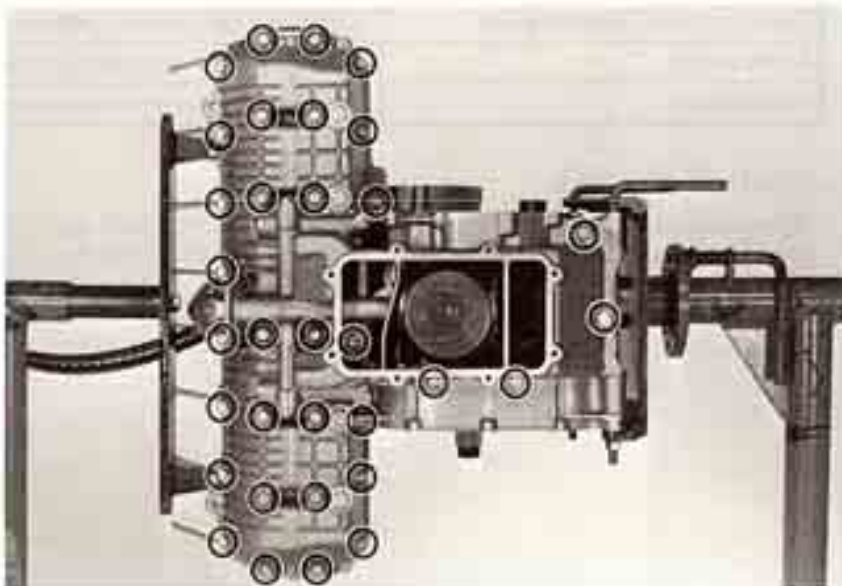





Separate the lower case half.

**CAUTION**

*Do not pry between the upper and lower cases.*

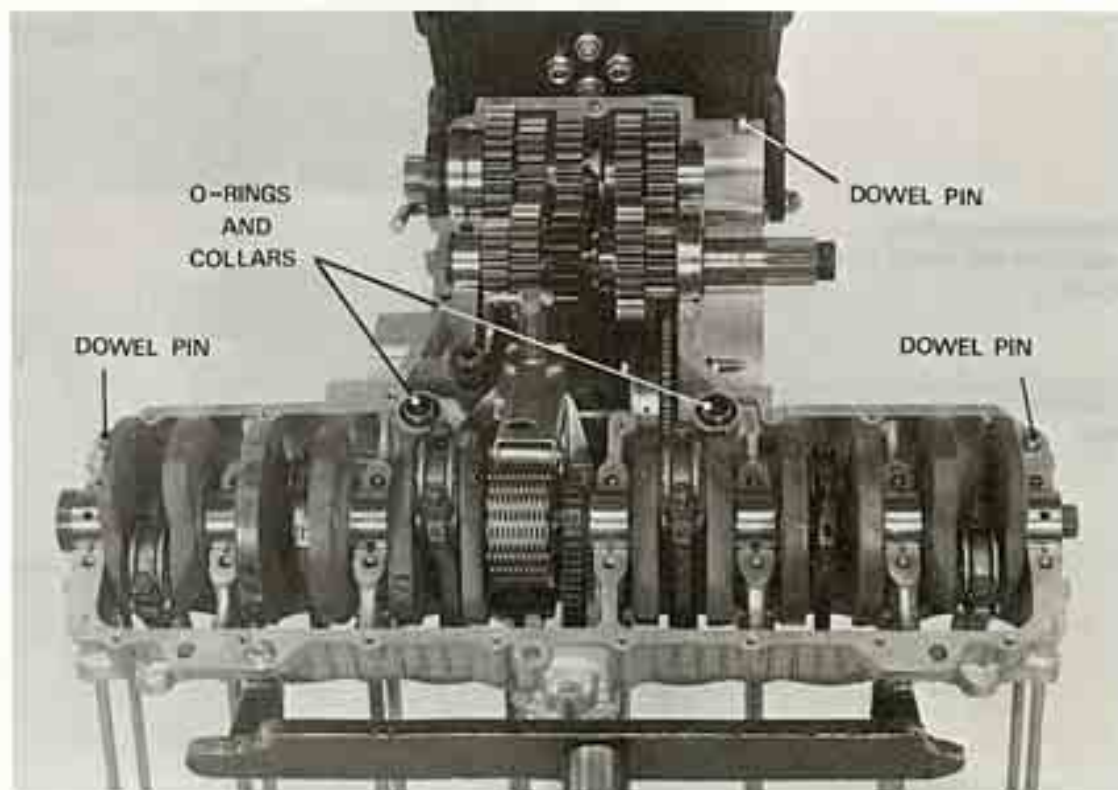
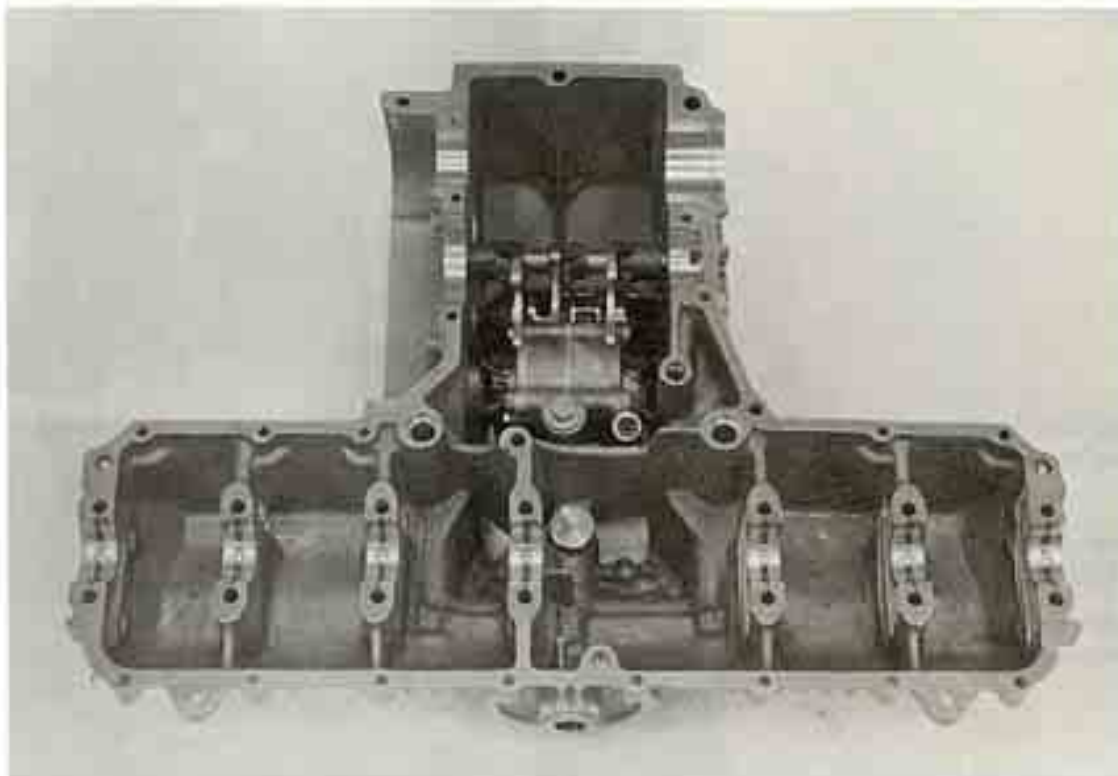



**CRANKCASE**

**CRANKCASE ASSEMBLY**

If the gearshift linkage, shift fork and shift drum are installed in the lower crankcase, shift the gearshift linkage into 1st gear for easier assembly.

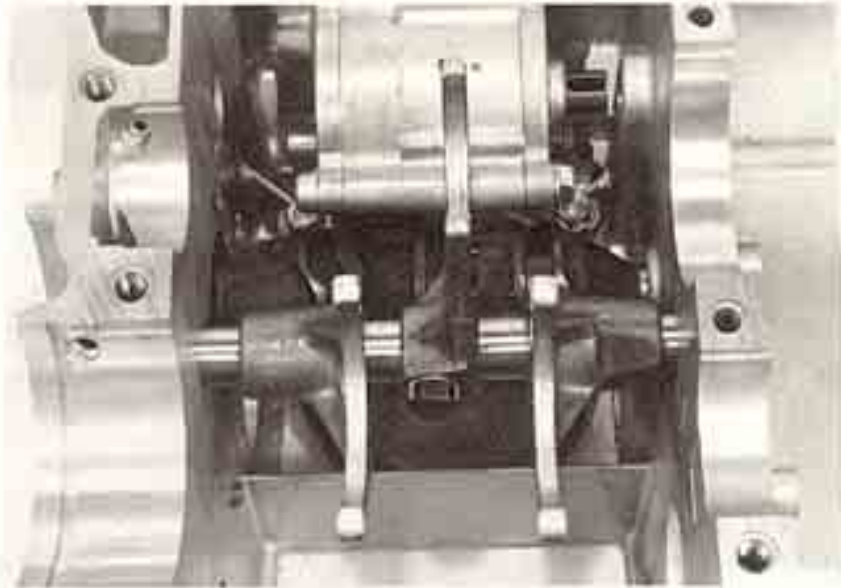

Slide the C4 gear into the C1 gear. Make sure that the other gears are not engaged.

Apply molybdenum disulfide grease to the groove of the M3 gear.

Apply molybdenum disulfide grease to the crankshaft main bearings.



Clean the crankcase mating surfaces. Apply liquid sealant to the mating surface of the lower crankcase.

**CAUTION**  
*Do not apply sealant to the portion near the main bearing.*

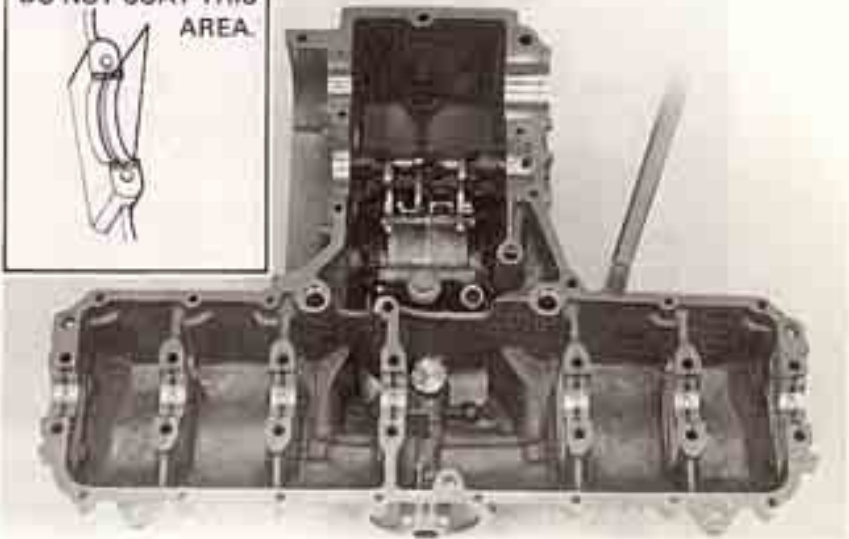





For the upper crankcase, apply sealant only where shown.

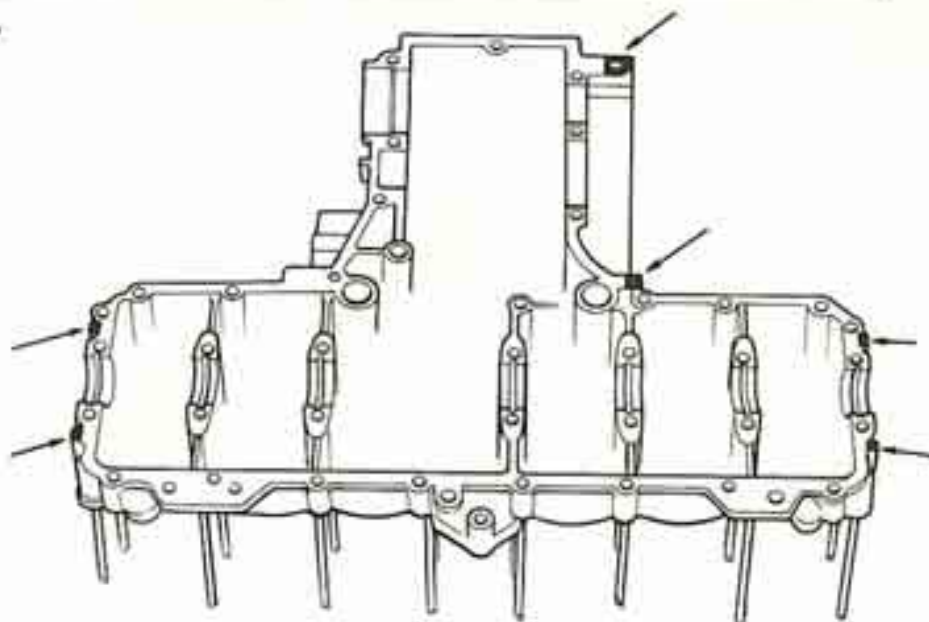

Assemble the crankcase halves, aligning the shift fork claws with the gears. Tighten the bolts to the specified torques in the sequence shown.

### TORQUE SPECIFICATIONS:

8 mm bolt (Crankshaft)	2.3–2.7 kg-m (17–20 ft-lb)
8 mm bolt (Crankcase)	2.3–2.7 kg-m (17–20 ft-lb)
6 mm bolt	1.0–1.4 kg-m (7–10 ft-lb)
10 mm bolt	3.3–3.7 kg-m (24–27 ft-lb)

### NOTE

- Make sure that the plain washers are under the crankshaft bearing bolts.
- Apply molybdenum disulfide grease to the threads and head of the fourteen crankshaft holding bolts.

Tighten the upper crankcase bolts to the specified torque, proceeding front to rear.

### NOTE

- If the oil path cap is removed, apply molybdenum disulfide grease to the threads when reinstalling.

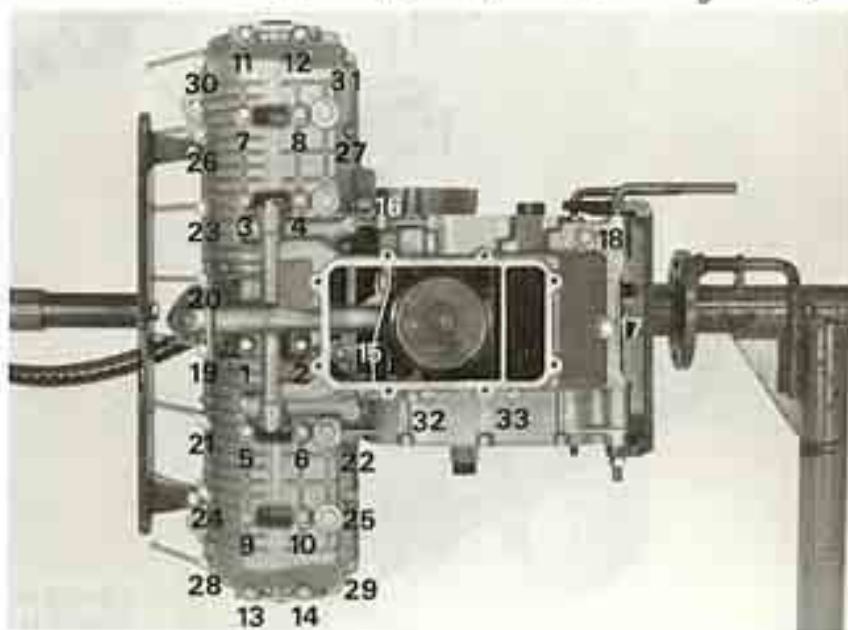

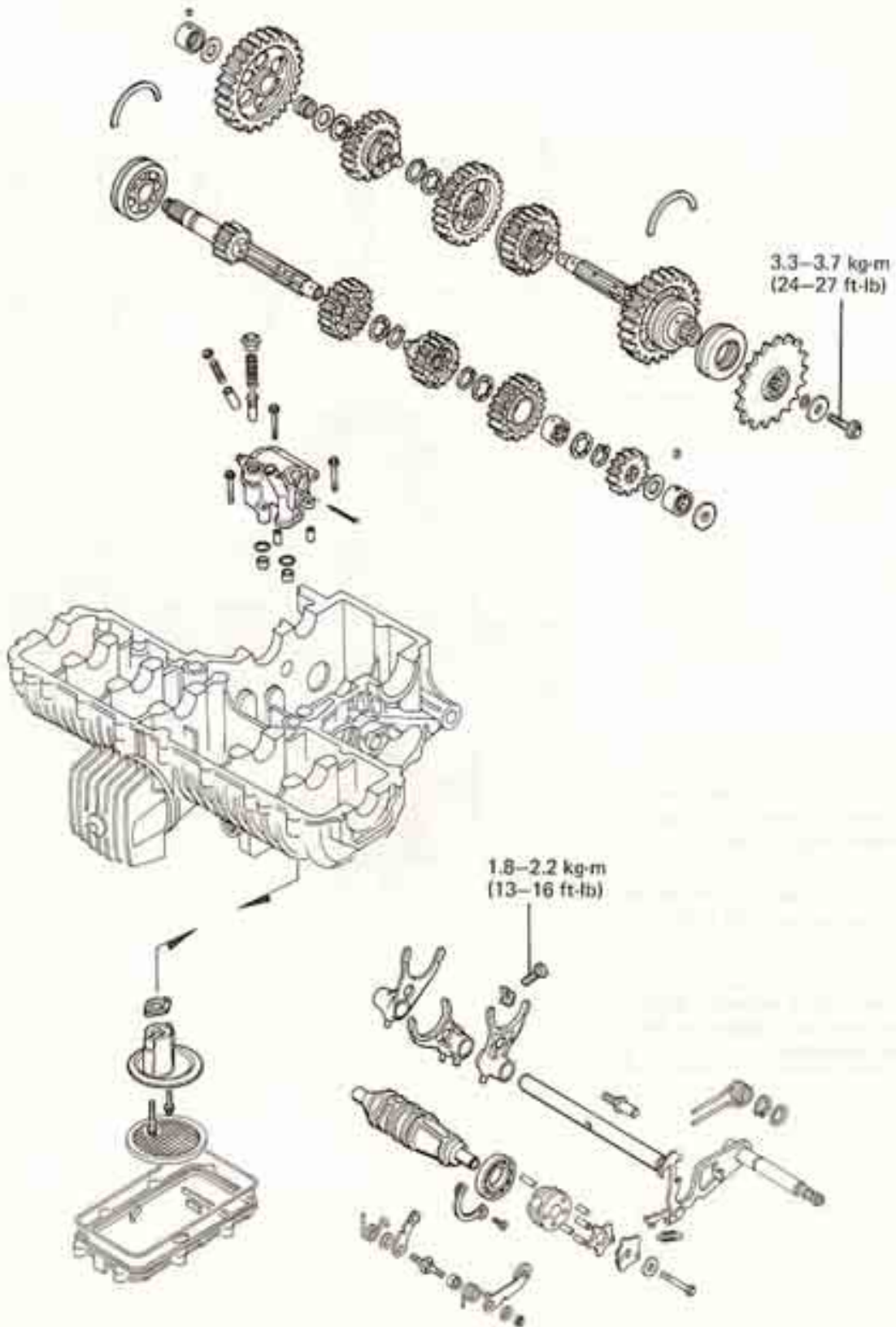





SERVICE INFORMATION	11-1
TROUBLESHOOTING	11-2
TRANSMISSION DISASSEMBLY	11-3
SHIFT FORK, SHIFT DRUM AND OIL PUMP REMOVAL	11-5
OIL PUMP DISASSEMBLY	11-7
OIL PUMP ASSEMBLY	11-10
OIL PUMP, SHIFT DRUM AND SHIFT FORK INSTALLATION	11-11
TRANSMISSION ASSEMBLY	11-13

## SERVICE INFORMATION

### WORKING PRACTICE

The gear shift linkage can be serviced with engine in the frame. For internal transmission repairs, the crankcase must be separated (Refer to Section 10).

### SPECIAL TOOLS

#### Common Tools

Driver Handle	07746-0030100
30mm Inner Driver	07746-0030300

### TORQUE VALUES

Drive sprocket	3.3-3.7 kg-m (24-27 ft-lb)
Shift fork shaft	1.8-2.2 kg-m (13-16 ft-lb)

### SPECIFICATIONS

			STANDARD	SERVICE LIMIT
Transmission	Backlash		0.024-0.074 mm (0.0009-0.0029 in)	0.12 mm (0.005 in)
	Gear I.D.	M4 gear	28.020-28.041 mm (1.1031-1.1040 in)	28.06 mm (1.105 in)
		M5 gear	31.000-31.025 mm (1.2205-1.2215 in)	31.04 mm (1.222 in)
		C1 gear	28.000-28.021 mm (1.1024-1.1032 in)	28.04 mm (1.104 in)
		C3 gear	28.020-28.041 mm (1.1031-1.1040 in)	28.06 mm (1.105 in)
	Gear bushing	M5 O.D.	30.950-30.975 mm (1.2185-1.2195 in)	30.93 mm (1.218 in)
		C1 O.D.	27.959-27.980 mm (1.1007-1.1016 in)	27.94 mm (1.100 in)
		C1 I.D.	24.007-24.028 mm (0.9452-0.9460 in)	24.05 mm (0.947 in)
	Mainshaft O.D.	at M4	27.959-27.980 mm (1.1007-1.1016 in)	27.94 mm (1.100 in)
	Countershaft O.D.	at C1 bushing	23.9935-24.0065 mm (0.9446-0.9451 in)	23.97 mm (0.944 in)
		at C3	27.959-27.980 mm (1.1007-1.1016 in)	27.94 mm (1.100 in)
	Gear to bushing or shaft clearance	M4 to shaft	—————	0.10 mm (0.004 in)
		M5 to M5 bushing	—————	0.10 mm (0.004 in)
		C1 to C1 bushing	—————	0.10 mm (0.004 in)
		C1 bushing to shaft	—————	0.10 mm (0.004 in)
C3 to shaft		—————	0.10 mm (0.004 in)	

**TRANSMISSION/OIL PUMP**

		Standard	Service limit	
Shift fork	Claw thickness	6.43–6.50 mm (0.253–0.256 in)	6.1 mm (0.24 in)	
	I.D.	Center	16.009–16.012 mm (0.6303–0.6304 in)	
		Left and right	16.000–16.021 mm (0.6299–0.6307 in)	16.55 mm (0.652 in)
Fork shaft	O.D.	15.966–15.984 mm (0.6286–0.6293 in)	15.95 mm (0.628 in)	
Oil pump	Pressure	Left pump	0.5–1.0 kg/cm <sup>2</sup> (7.1–14.2 psi)	
		Right pump	4.0–5.3 kg/cm <sup>2</sup> (56.9–75.4 psi)	
	Left pump clearances	Tip clearance	0.08–0.12 mm (0.003–0.005 in)	0.15 mm (0.006 in)
		Body clearance	0.15–0.21 mm (0.006–0.008 in)	0.35 mm (0.014 in)
		End clearance	0.02–0.07 mm (0.001–0.003 in)	0.10 mm (0.004 in)
	Right pump clearances	Tip clearance	0.08–0.12 mm (0.003–0.005 in)	0.15 mm (0.006 in)
		Body clearance	0.15–0.21 mm (0.006–0.008 in)	0.35 mm (0.014 in)
		End clearance	0.02–0.07 mm (0.001–0.003 in)	0.10 mm (0.004 in)

**TROUBLESHOOTING****Hard to shift**

1. Improper clutch adjustment: too much free play
2. Shift fork bent
3. Shift shaft bent
4. Shift claw bent
5. Shift drum cam grooves damaged

**Transmission Jumps Out of Gear**

1. Gear dogs worn
2. Shift shaft bent
3. Shift drum stopper broken
4. Shift forks bent

**Low Oil Pressure**

1. Pressure relief valve stuck open
2. Plugged oil pick-up screen
3. Oil pump worn
4. External oil leaks
5. Oil level low

**High Oil Pressure**

1. Pressure relief valve stuck closed
2. Plugged oil filter, gallery, or mating orifice
3. Incorrect oil being used

**No Oil Pressure**

1. Oil level low
2. Oil pump drive chain broken
3. Oil pump faulty
4. Internal oil leakage





For servicing of the gearshift linkage, see Section 9.

## TRANSMISSION DISASSEMBLY

Separate the crankcase (Section 10).  
Inspect each gear for backlash.

**SERVICE LIMIT: 0.12 mm (0.005 in)**

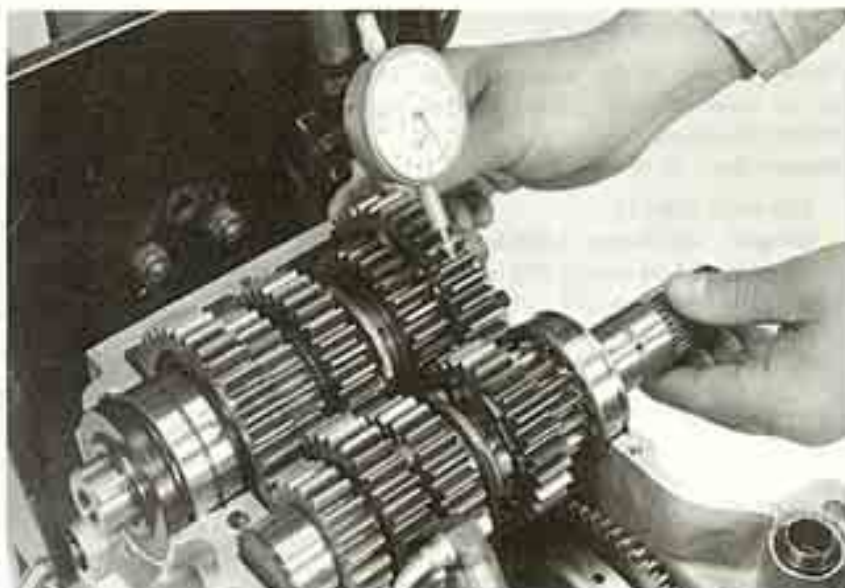

Remove the main and countershafts.  
Remove the dowel pins from the crankcase.

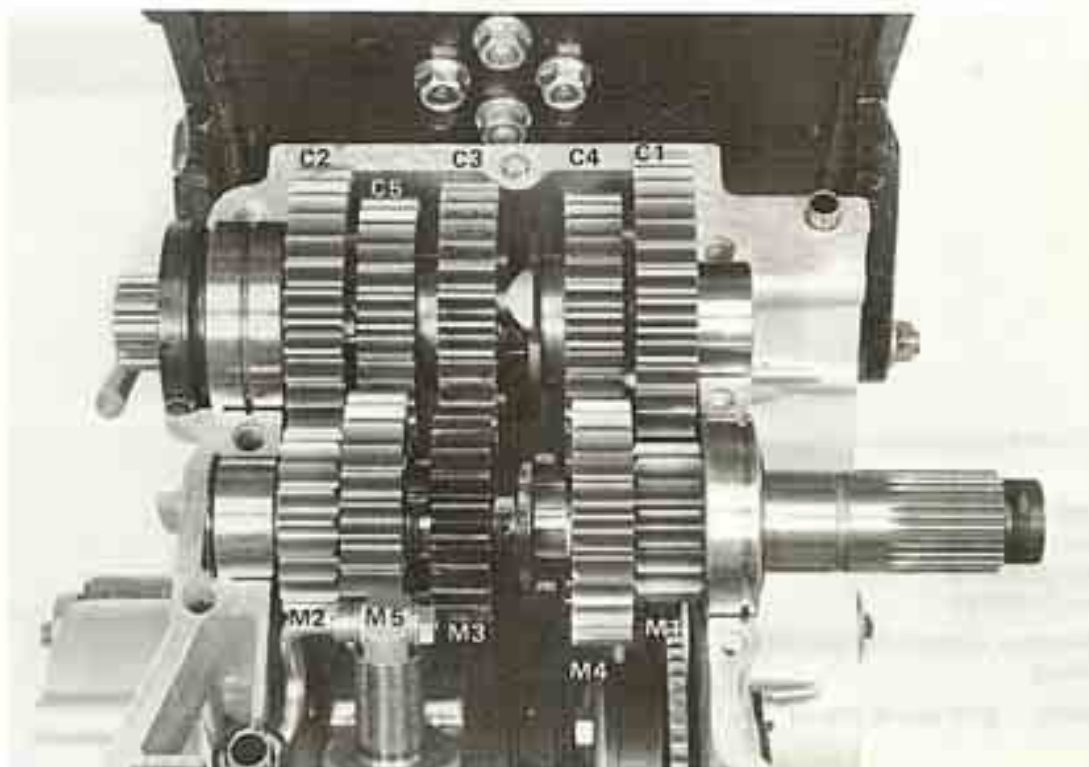



**TRANSMISSION INSPECTION**

Check gear dogs, dog hole and teeth for excessive or abnormal wear, or evidence of insufficient lubrication.

Measure the I. D. of each gear.

**SERVICE LIMITS:**

- M4 gear: 28.06 mm (1.105 in)
- M5 gear: 31.04 mm (1.222 in)
- C 1 gear: 28.04 mm (1.104 in)
- C 3 gear: 28.06 mm (1.105 in)

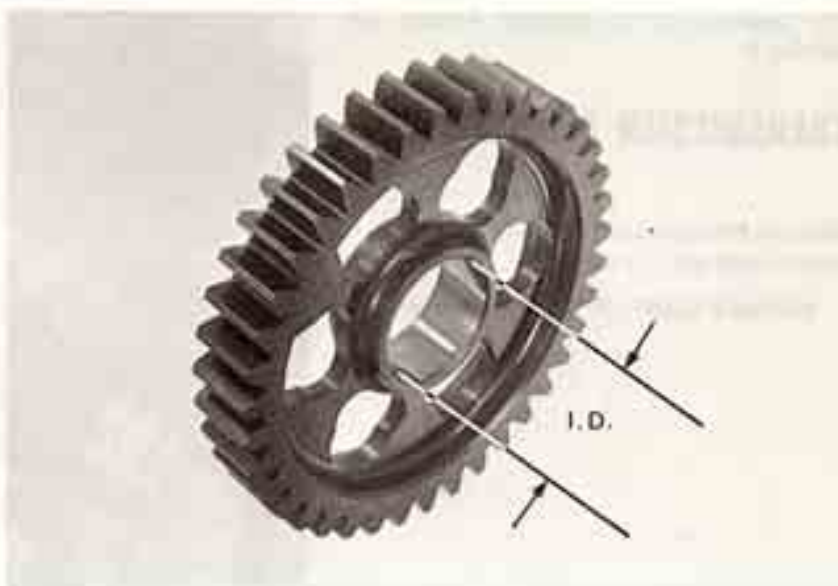

Measure the I.D. and O.D. of the gear bushings.

**SERVICE LIMITS:**

- M5 O.D.: 30.93 mm (1.218 in)
- C 1 O.D.: 27.94 mm (1.100 in)
- C 1 I.D.: 24.05 mm (0.947 in)

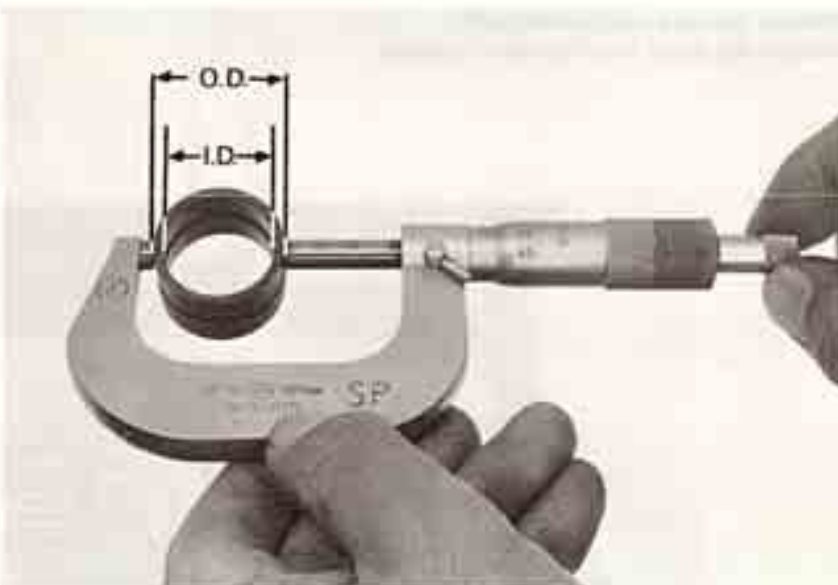

Measure the O.D. of the mainshaft and countershaft.

**SERVICE LIMITS:**

- A: 27.94 mm (1.100 in)
- B: 23.97 mm (0.944 in)
- C: 27.94 mm (1.100 in)

Calculate the clearance between the gear and gear shaft or bushing.

**SERVICE LIMIT: 0.10 mm (0.004 in)**

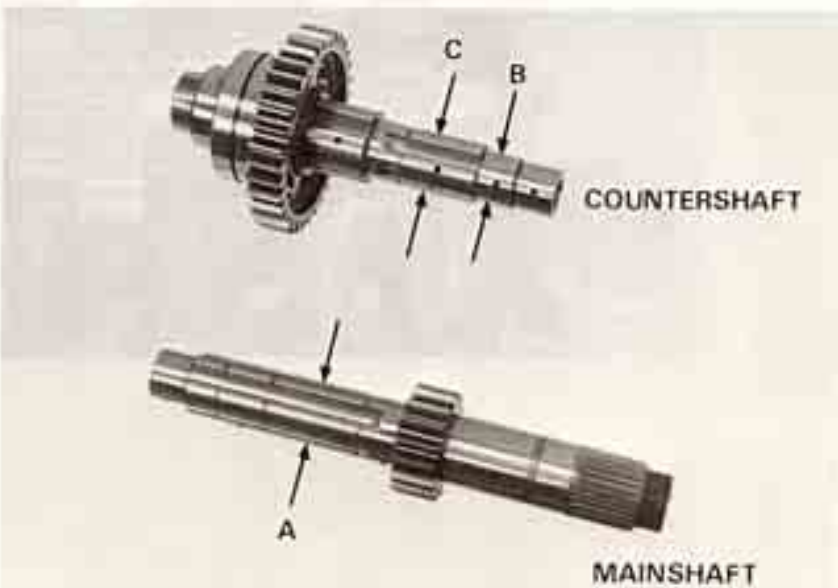





## SHIFT FORK, SHIFT DRUM AND OIL PUMP REMOVAL

Remove the oil strainer.

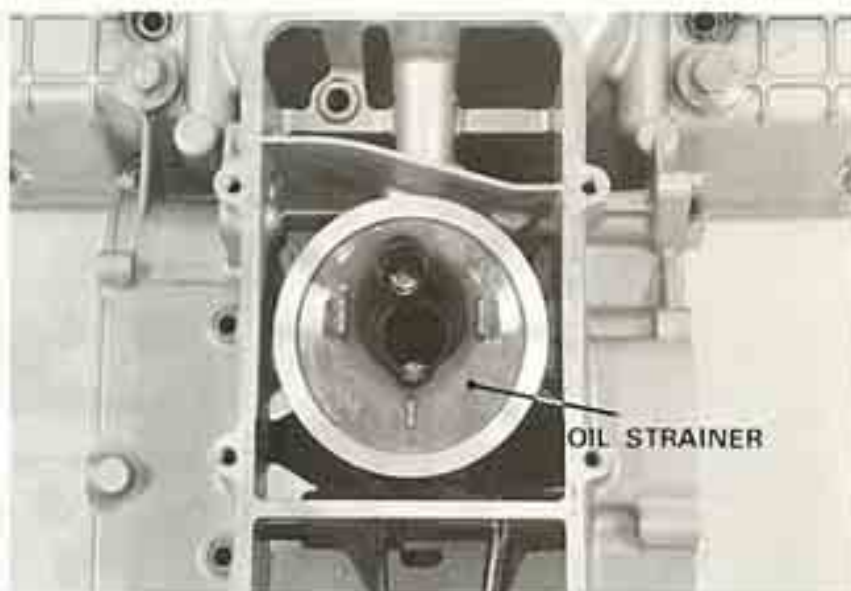

Remove the bearing stopper plate.  
Remove the bearing.



Bend the tabs of the lock washer at the center  
shift fork.  
Loosen the bolt.  
Remove the shift fork shaft.  
Remove the shift forks, shaft and shift drum.

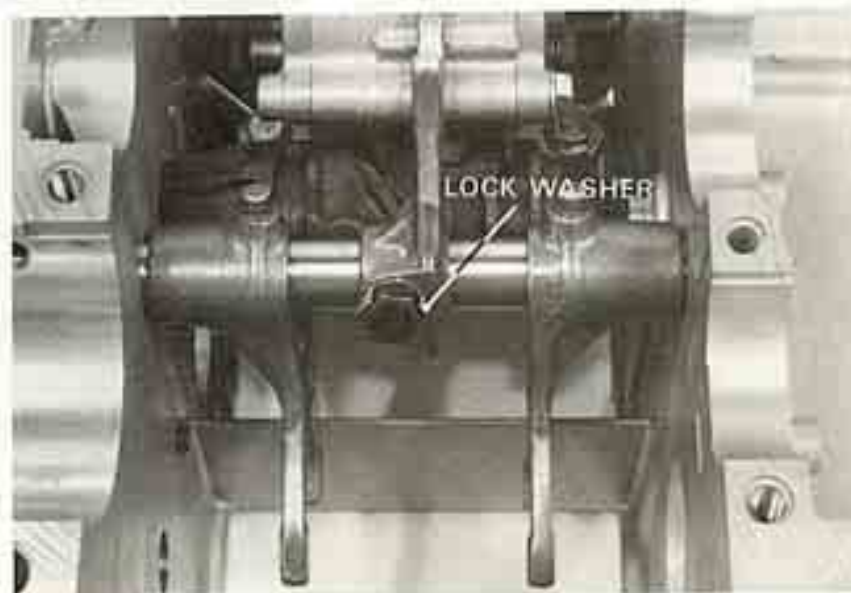



Remove the oil pump.

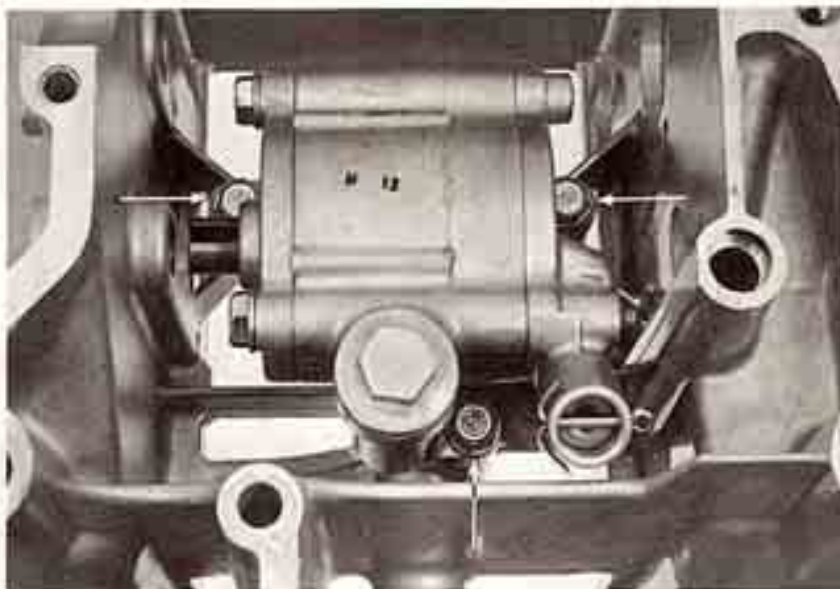

#### GEAR SHIFT DRUM AND SHIFT FORK INSPECTION

Inspect the shift drum end for scoring, scratches, or evidence of insufficient lubrication.

Check the shift grooves for damage.



Inspect the shift drum hole and shift fork shaft hole for scoring or scratches.







Measure the shift fork shaft O.D.  
Check for scratches, scoring, or evidence of  
insufficient lubrication.



Measure the shift fork I.D. and claw thick-  
ness.



## OIL PUMP DISASSEMBLY

Remove the relief valve cap and cotter pin.

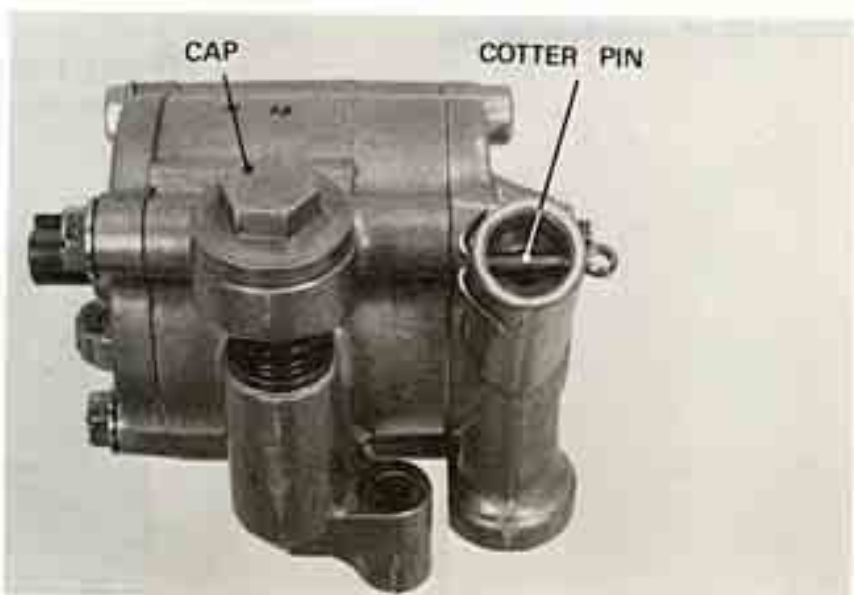



**TRANSMISSION/OIL PUMP**

Remove the oil pump side covers.



**OIL PUMP INSPECTION**

Measure the left pump tip clearance.

**SERVICE LIMIT:**  
**0.15mm (0.006in)**



Measure the left pump body clearance.

**SERVICE LIMIT:**  
**0.35mm (0.014in)**







Measure the left pump end clearance.



Measure the right pump tip clearance.



Measure the right pump body clearance.





**TRANSMISSION/OIL PUMP**

Measure the right pump end clearance.



**RELIEF VALVE INSPECTION**

Check that the plungers operate smoothly and that the springs are not damaged or weak. Replace the relief valve as a unit if the spring must be replaced.

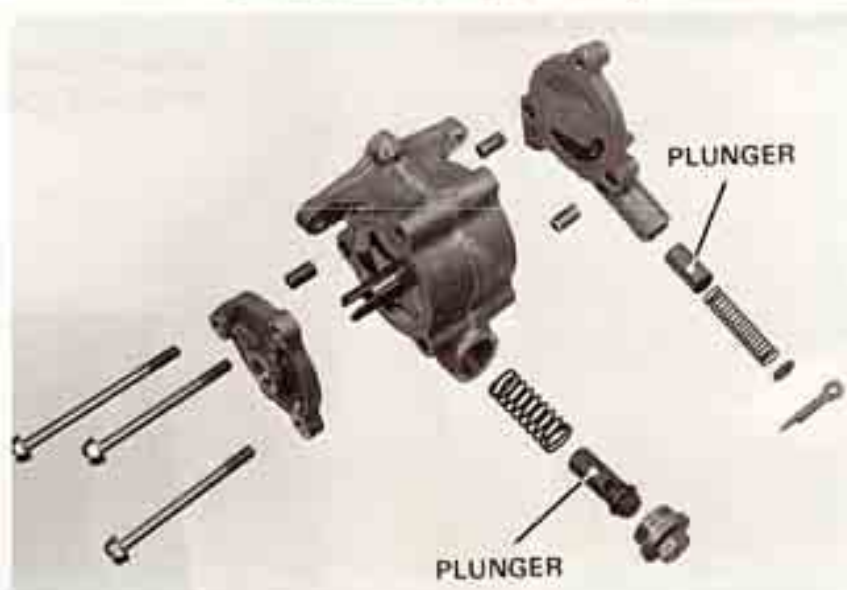

**OIL PUMP ASSEMBLY**

Install the left outer rotor.  
Insert the drive pin into the shaft.  
Align the slot in the left inner rotor with the drive pin.

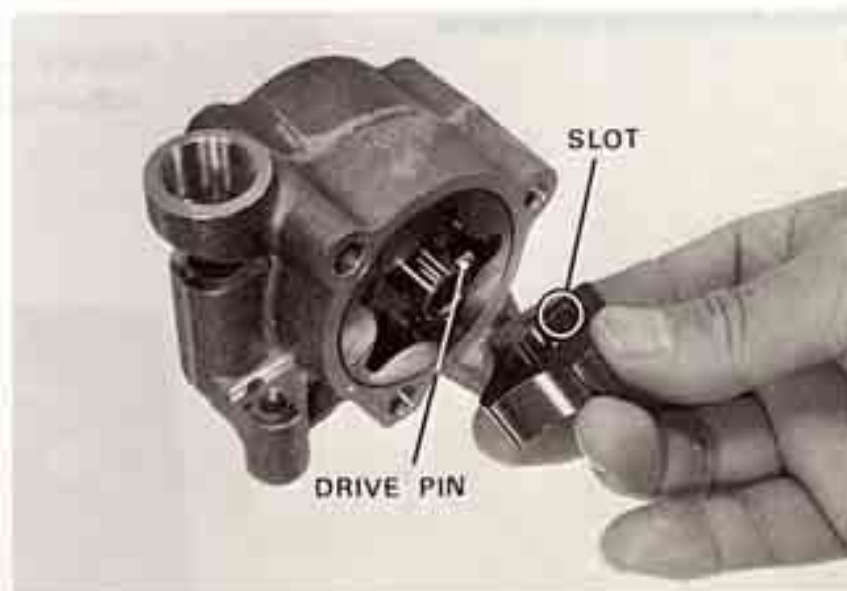



Install the right outer rotor.  
Insert the drive pin into the shaft.  
Align the slot in the inner rotor with the drive pin.

Install the side covers.  
Install the relief valves.

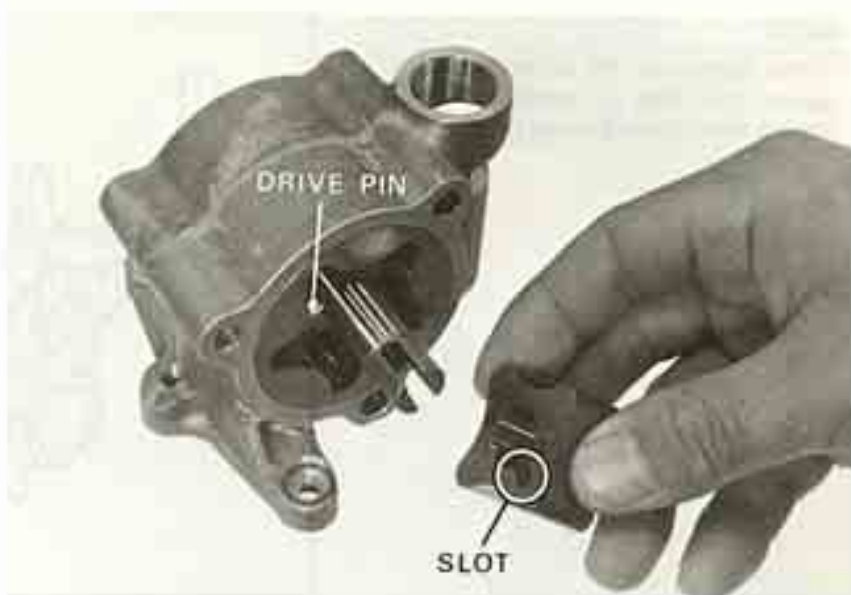

## **OIL PUMP, SHIFT DRUM AND SHIFT FORK INSTALLATION**

To install the oil pump, shift drum and shift fork, reverse the removal procedure.  
Key points are shown here.

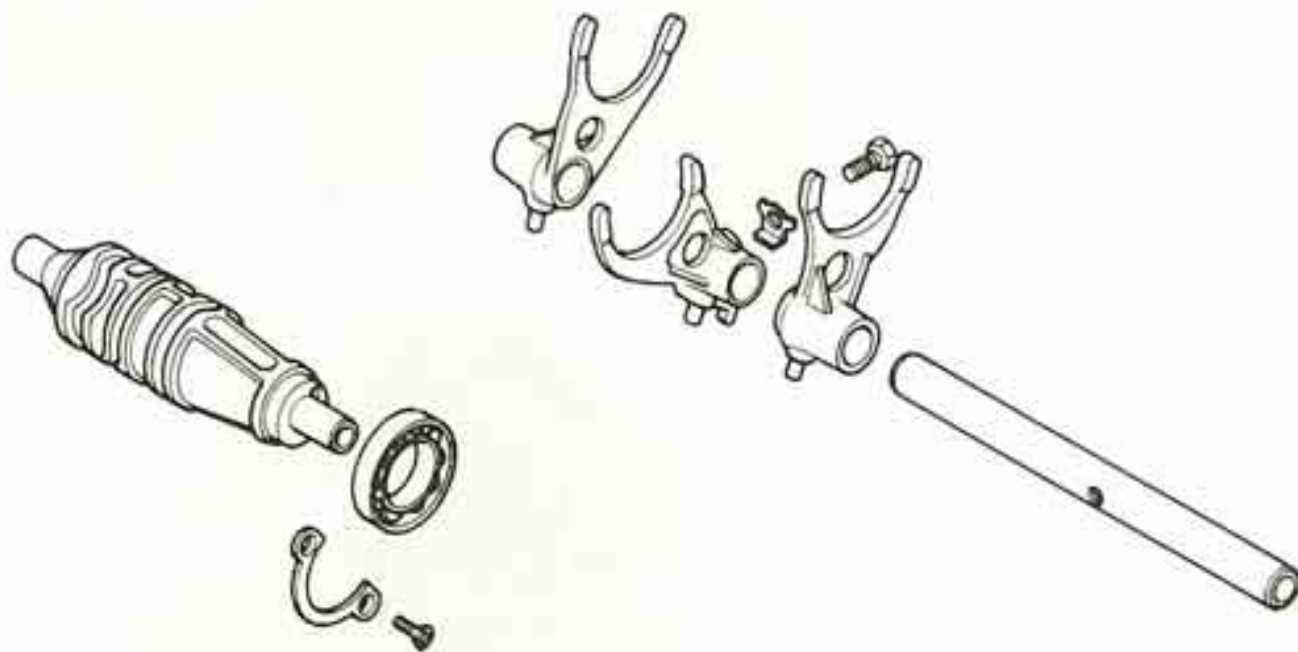





**NOTE**

After tightening the center shift fork, secure the bolt by bending the lock washer tabs against the bolt head.

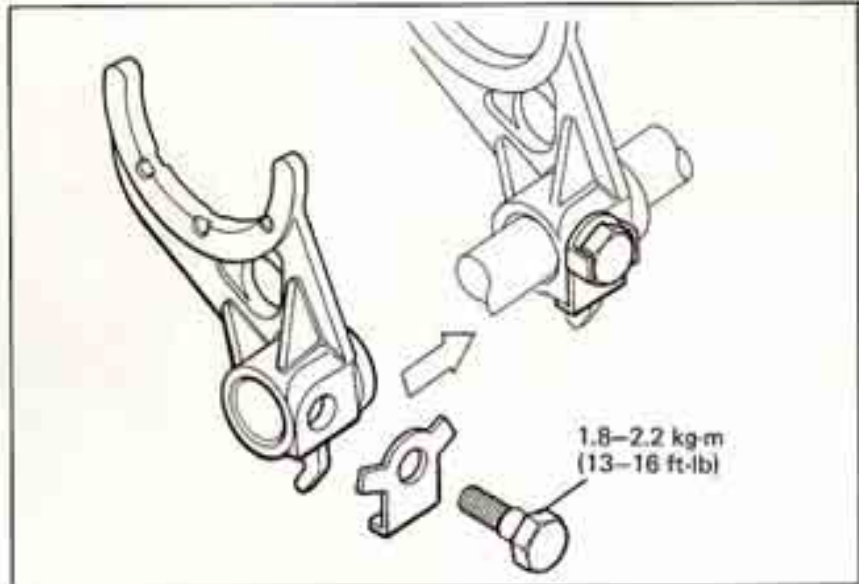

**NOTE**

When installing the bearing stopper plate, apply a locking agent to the screw threads.



**CAUTION**

The oil strainer bolts are different lengths. Use the bolts correctly when installing the oil strainer. If the bolts are used incorrectly, the shift drum may lock.





### TRANSMISSION ASSEMBLY

Assemble the mainshaft and countershaft.

#### CAUTION

Note the installation direction of the C3 gear. The 8.5 mm recess should face the C5 gear. The 4.0 mm recess should face the C4 gear. If installed incorrectly, proper gear engagement will not occur.

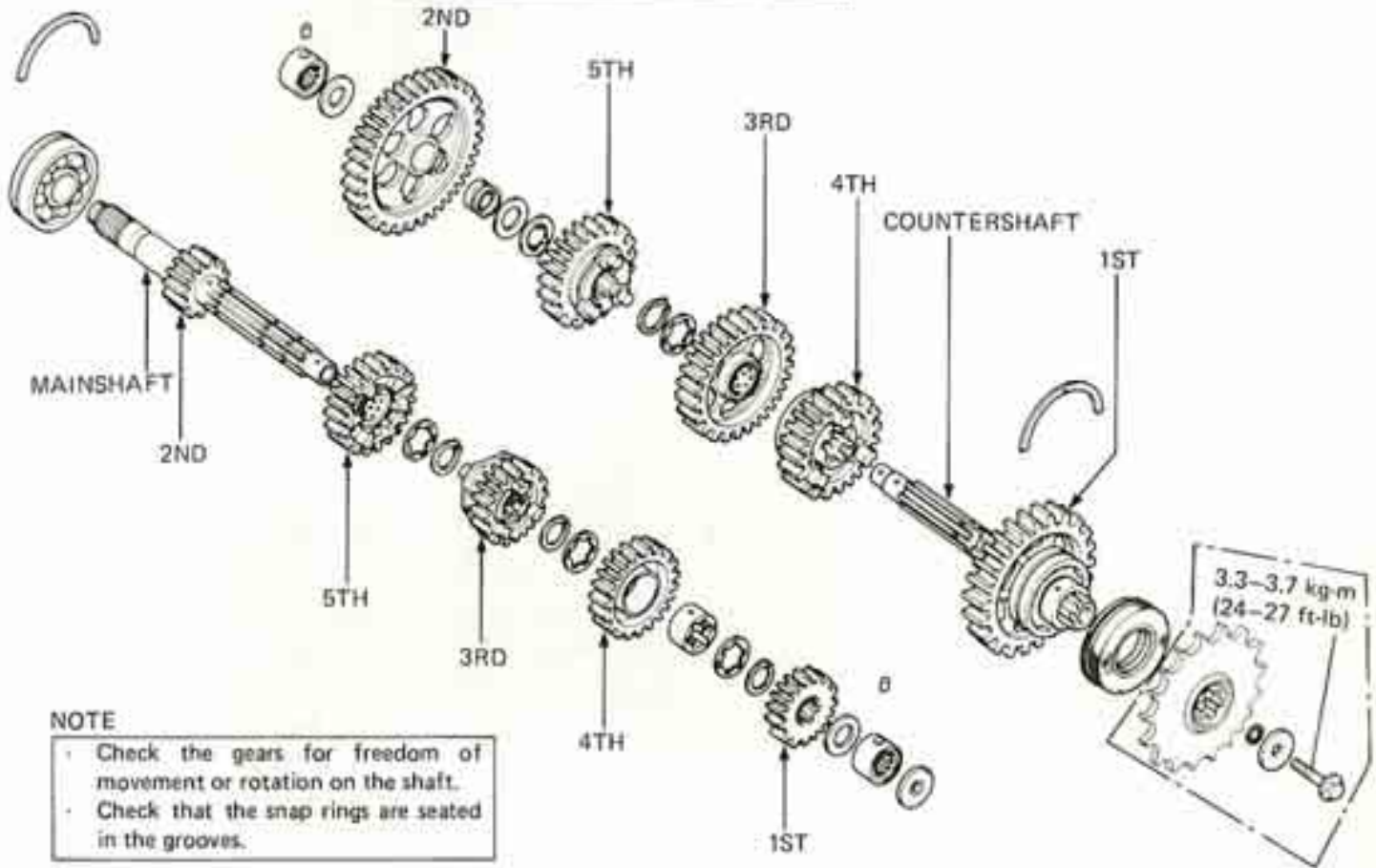

#### NOTE

- Check the gears for freedom of movement or rotation on the shaft.
- Check that the snap rings are seated in the grooves.

#### NOTE

- Install the mainshaft bearing with the special tools.

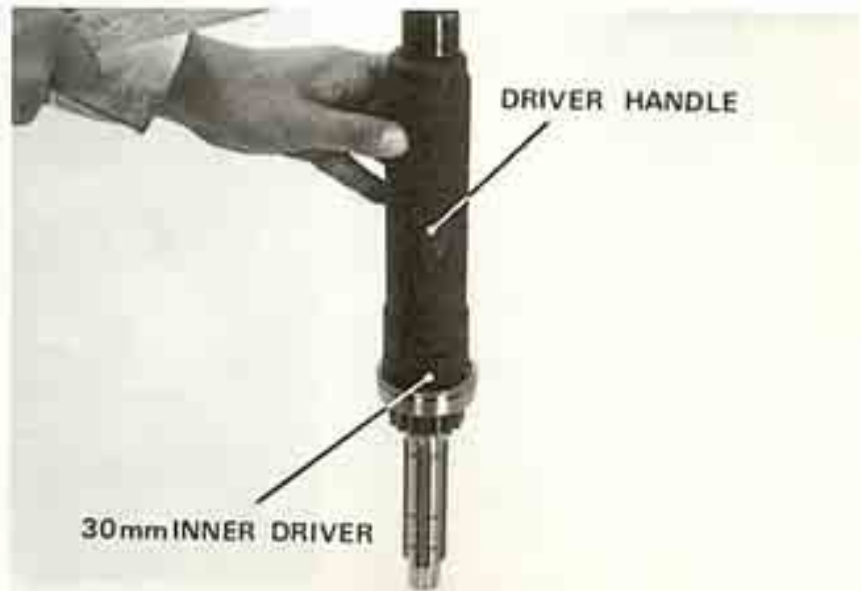



**TRANSMISSION/OIL PUMP**

Align the hole in the M5 gear bushing with the hole in the mainshaft.



Align the hole in the C5 gear with the hole in the countershaft.

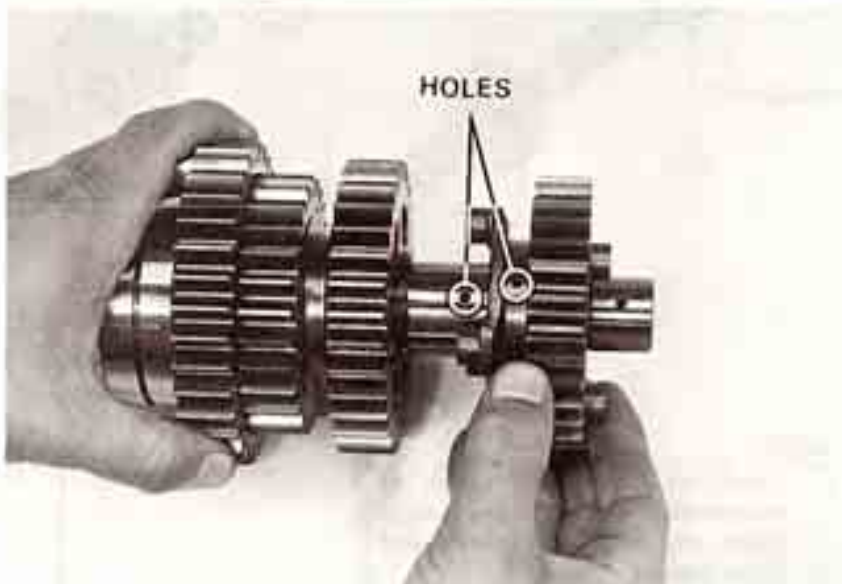

Insert the dowel pins.

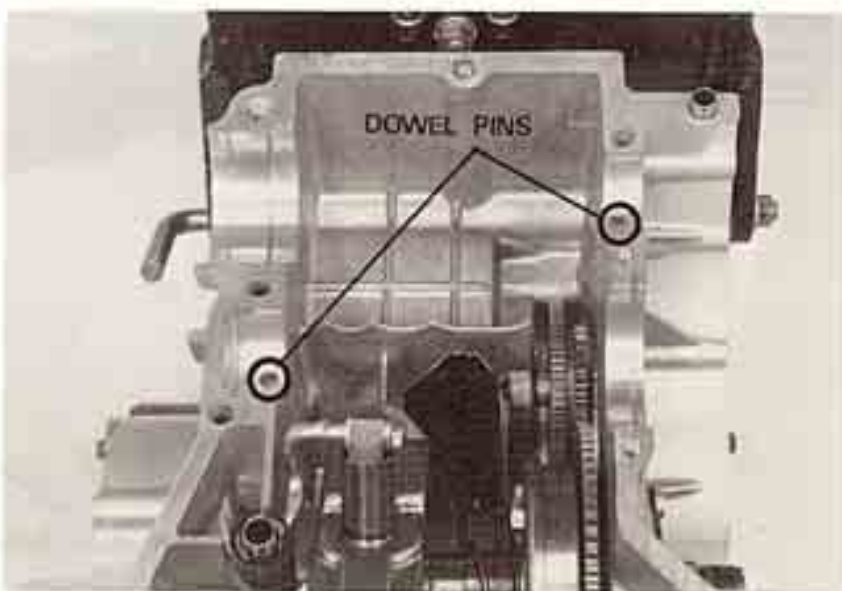





Align the holes in the mainshaft bearing and countershaft bearing with the dowel pins.

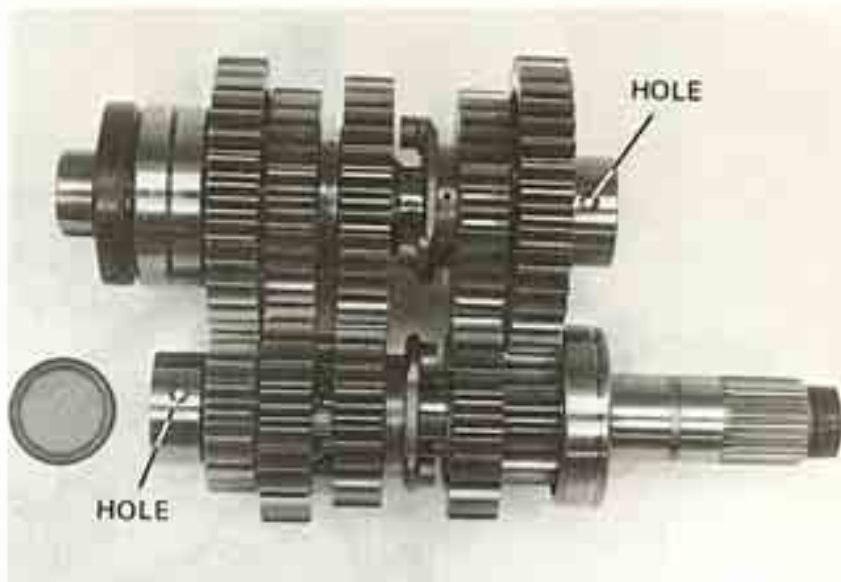

**NOTE**

- Install the countershaft oil seal carefully so that the oil seal lip is seated completely on the bearing before assembling the lower crankcase.
- Apply molybdenum disulfide grease to the shift fork groove of M-3 gear.

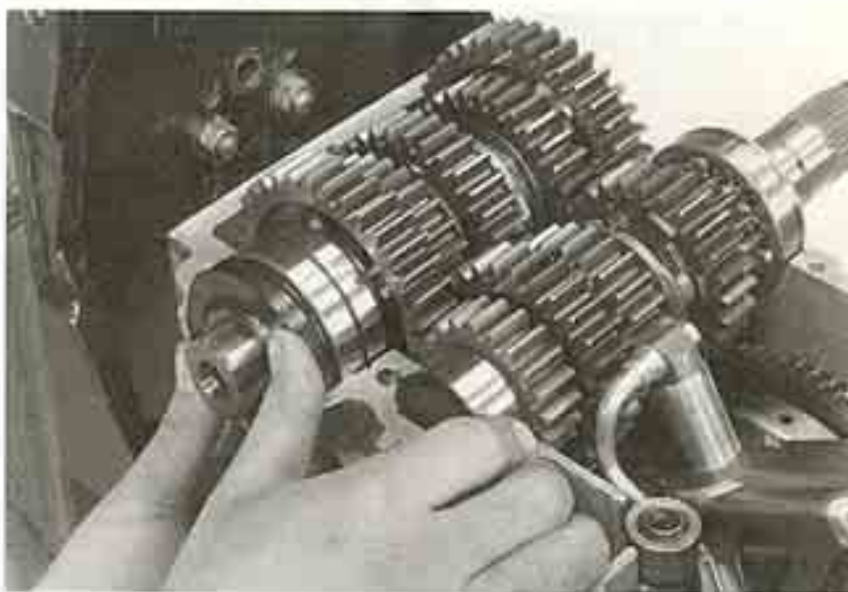

Install the lower crankcase (Refer to Section 10).

**NOTE**

- Check the oil orifice for clogging before installing the lower crankcase.





**CRANKSHAFT/PRIMARY SHAFT**

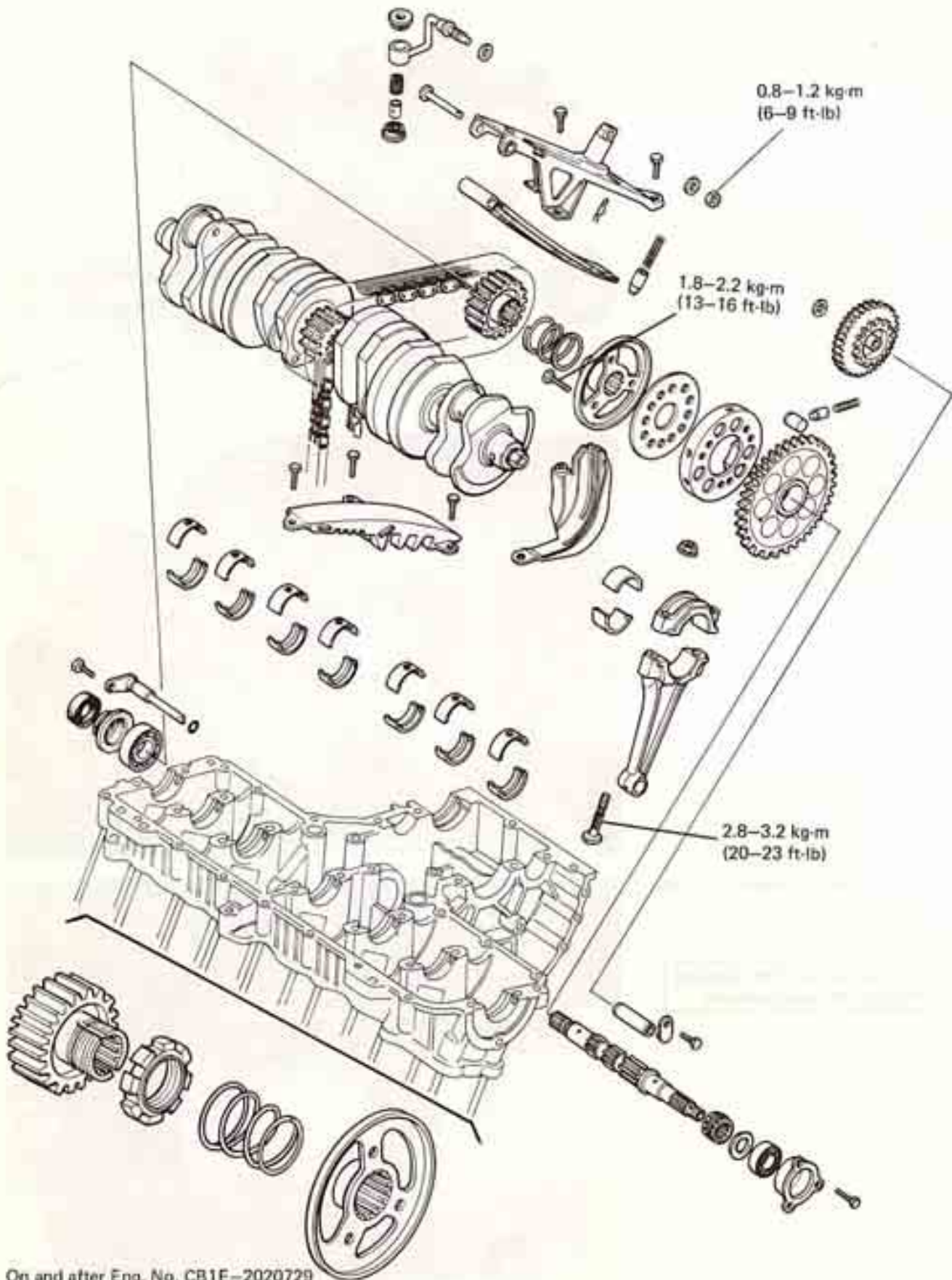

On and after Eng. No. CB1E-2020729





SERVICE INFORMATION	12-1
TROUBLESHOOTING	12-1
PRIMARY SHAFT/STARTER CLUTCH REMOVAL	12-2
PRIMARY SHAFT DISASSEMBLY	12-3
STARTER CLUTCH DISASSEMBLY	12-4
PRIMARY CHAIN TENSIONER DISASSEMBLY	12-5
CONNECTING ROD REMOVAL	12-6
BEARING INSPECTION	12-8
BEARING SELECTION	12-10
CONNECTING ROD INSTALLATION	12-12
OIL SEAL AND BEARING INSTALLATION	12-14
PRIMARY SHAFT ASSEMBLY	12-15
STARTER CLUTCH ASSEMBLY	12-16
PRIMARY SHAFT INSTALLATION	12-16
STARTER IDLE GEAR INSTALLATION	12-18
PRIMARY CHAIN TENSIONER ASSEMBLY	12-19

## SERVICE INFORMATION

### WORKING PRACTICE

All bearing inserts are select fit and are identified by color code. Select replacement bearings from the code tables. After installing new bearings, recheck them with plastigauge to verify clearance.

Apply molybdenum disulfide grease to the main journals and crankpins during assembly.

### SPECIAL TOOLS

#### Common Tools

Driver Handle	07749-0010000
25mm Driver pilot	07746-0040600
37 x 40mm Outer Driver	07746-0010200
52 x 55mm Outer Driver	07746-0010400
Driver Handle	07746-0030100
25 mm Inner driver	07746-0030200
Primary shaft holder	07924-6340300

#### Special Tools

Pin Spanner 55 mm	07902-4220000
-------------------	---------------

### TORQUE VALUES

Crankpin	2.8-3.2 kg-m (20-23 ft-lb)
Starter clutch	1.8-2.2 kg-m (13-16 ft-lb)
Crankshaft	2.3-2.7 kg-m (17-20 ft-lb)
Primary chain tensioner nut	0.8-1.2 kg-m ( 6- 9 ft-lb)
Primary driven sprocket	See page 12-18

### SPECIFICATIONS

		STANDARD	SERVICE LIMIT
Electric Starter	Drive gear O.D.	47.175-47.200 mm (1.8573-1.8583 in)	47.155 mm (1.8565 in)
	Idle gear I.D.	10.000-10.015 mm (0.3937-0.3943 in)	10.04 mm (0.395 in)
	Idle gear shaft O.D.	9.972-9.987 mm (0.3926-0.3932 in)	9.95 mm (0.392 in)
	Idle gear-to-shaft clearance	—	0.1 mm (0.004 in)
Crankshaft	Connecting rod big end side clearance	0.05-0.20 mm (0.002-0.008 in)	0.3 mm (0.01 in)
	Runout	—	0.05 mm (0.002 in)
	Crankpin oil clearance	0.020-0.060 mm (0.0008-0.0024 in)	0.08 mm (0.003 in)
	Main journal oil clearance	0.020-0.060 mm (0.0008-0.0024 in)	0.08 mm (0.003 in)
Cam chain	Length	260.35-260.57 mm (10.250-10.259 in)	261.8 mm (10.31 in)
Primary chain	Length	194.65-194.92 mm (7.663-7.674 in)	195.8 mm (7.71 in)

## TROUBLESHOOTING

### Excessive Noise

-Worn main journal bearing      -Worn crank pin bearing





## PRIMARY SHAFT/STARTER CLUTCH REMOVAL

Disassemble the crankcase (Section 10).  
 Remove the primary shaft drive gear (Section 8).  
 Remove the starting motor (Section 18).  
 Remove the transmission assembly (Section 11).  
 Remove the A. C. generator (Section 16).

Remove the starter idle gear shaft holder.  
 Loosen the primary shaft bearing holder bolts.

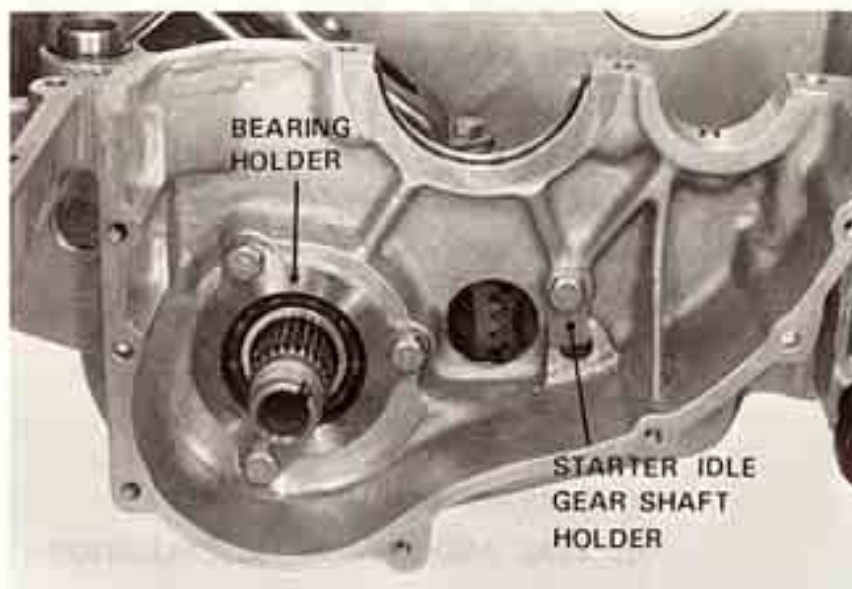

Remove the starter idle gear shaft.  
 Remove the starter idle gear and wave washer.  
 Remove the primary chain tensioner.

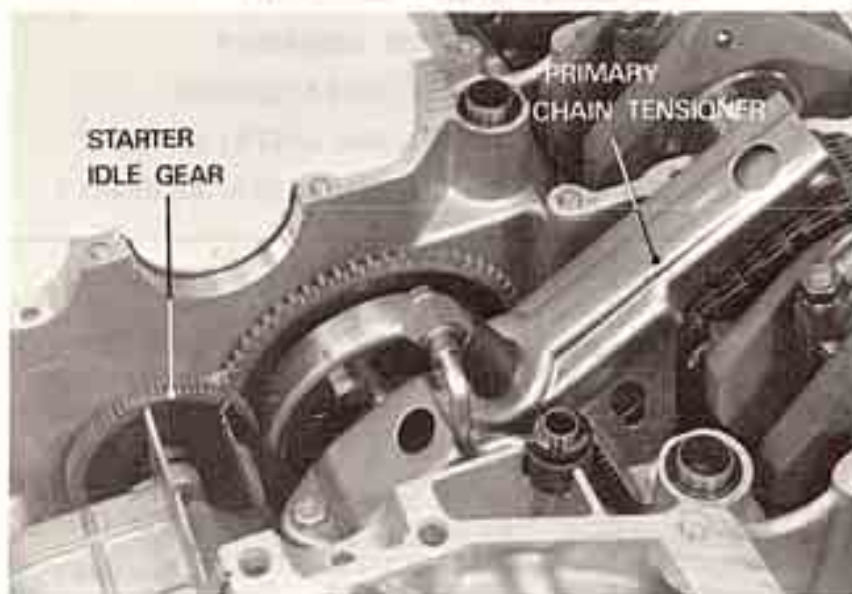

Remove the oil supply nozzle.

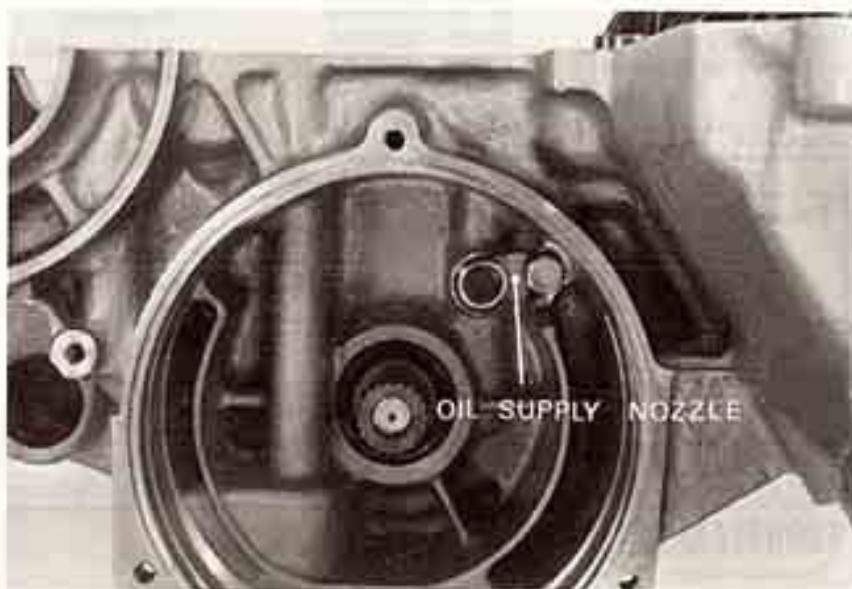



On and after Eng. No. CB1E-2020729

Hold the shaft with the special "PRIMARY SHAFT HOLDER" tool.

Loosen the primary driven sprocket collet ring nut with the special tool "PIN SPANNER".

**NOTE**

The ring nut has left-hand threads.

Remove the drive gear and then primary shaft.

RING NUT



Lift the primary driven sprocket and starter clutch and remove the primary chain. Remove the primary driven sprocket, ring nut, spring and starter clutch.



### PRIMARY SHAFT DISASSEMBLY

Remove the bearing holder.

Remove the bearing from the holder.

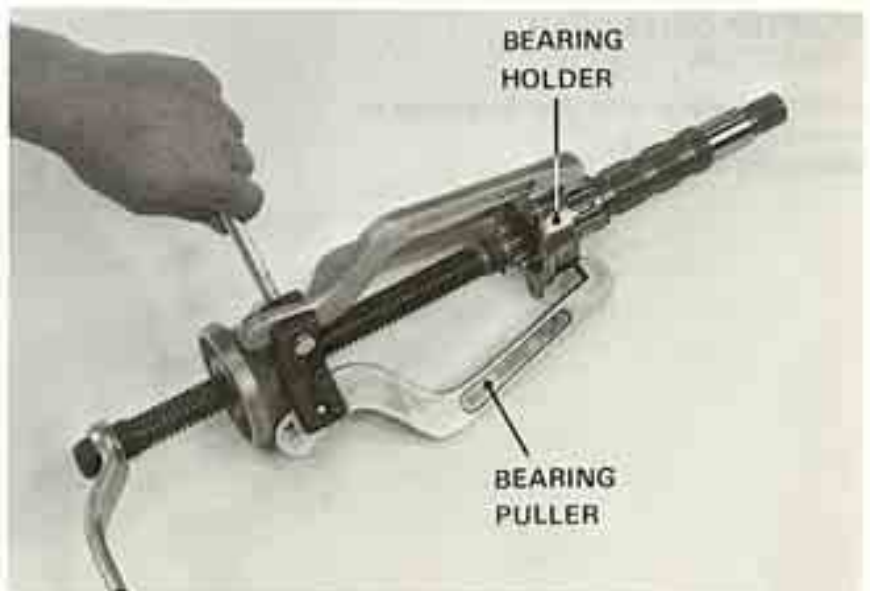





**CRANKSHAFT/PRIMARY SHAFT**

**PRIMARY SHAFT INSPECTION**

Check for scoring, wear or other damage.

**BEARING INSPECTION**

Check for damage.

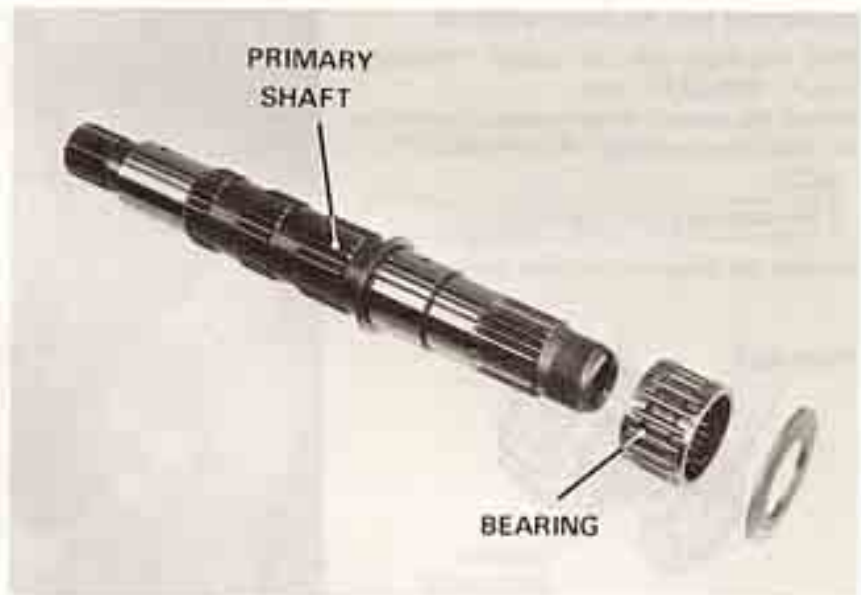

**STARTER CLUTCH DISASSEMBLY**

**STARTER CLUTCH INSPECTION**

Inspect the rollers for smooth operation.  
Remove the roller and check for excessive wear.  
Clean all parts with non-flammable or high flashpoint solvent.

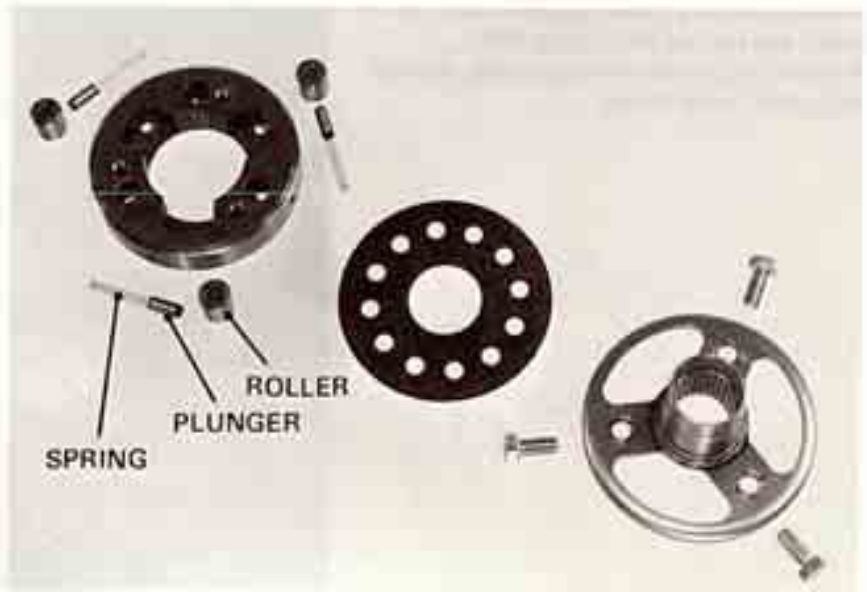

**STARTER DRIVE GEAR INSPECTION**

Inspect the starter drive gear for damage or excessive wear.  
Measure the O. D..







### STARTER IDLE GEAR INSPECTION

Inspect the idle gear for tooth damage.  
Measure the idle gear I. D.

SERVICE LIMIT:  
10.04 mm (0.395 in)



Measure the idle gear shaft O. D.  
Measure the idle gear-to-shaft clearance.

SERVICE LIMIT: 0.1 mm (0.004 in)

SERVICE LIMIT:  
9.95mm (0.392 in)



### PRIMARY CHAIN TENSIONER DISASSEMBLY

Remove the inner oil pipe and screen.  
Remove the spring and plunger.  
Remove the lock pin and slipper.  
Remove the nut and oil pipe.

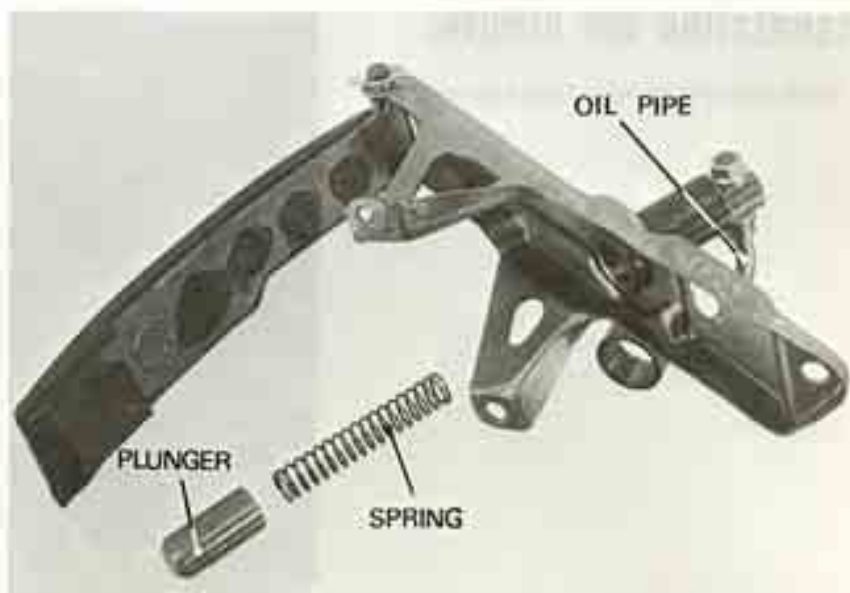



**CRANKSHAFT/PRIMARY SHAFT**

**INSPECTION**

Check the holes in the oil pipes and plunger for blockage.  
Clean all parts with non-flammable or high flashpoint-solvent.

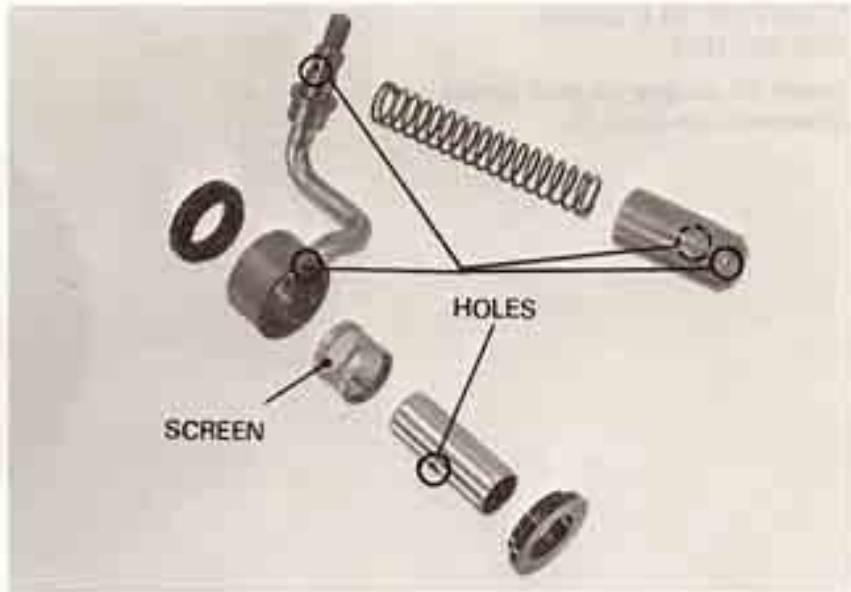

Inspect the slipper for damage or excessive wear.



**CONNECTING ROD REMOVAL**

Check the connecting rod side clearance.





Remove the bearing caps and rods.



**NOTE**

Mark the rods, bearings and bearing caps to indicate cylinder position.



**CRANKSHAFT INSPECTION**

Remove the cam chain and primary chain.

Set the crankshaft on a stand or V blocks.  
Set a dial gauge into the center main journal.  
Rotate the crankshaft two revolutions and read runout at the center journal.

Actual runout is 1/2 of Total Indicator Reading.

**SERVICE LIMIT:**  
**0.05mm (0.002in)**

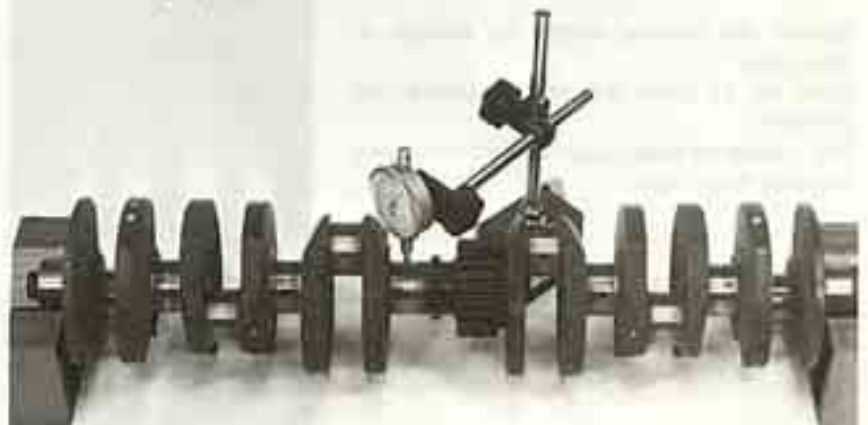



**CAM CHAIN LENGTH  
MEASUREMENT**

Place the cam chain over the intake cam sprockets.

Secure one sprocket. Apply 2–10 kg (4.4–22.1 lb) of tension with a spring scale to the other sprocket.

Measure the chain length as shown.

**SERVICE LIMIT: 261.8 mm (10.31 in)**

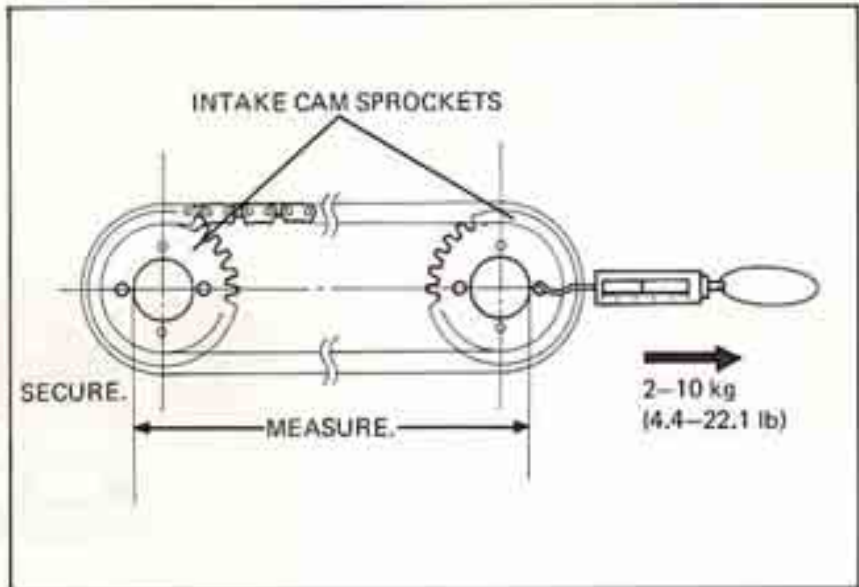
**PRIMARY CHAIN LENGTH  
MEASUREMENT**

Place the primary chain over the primary driven sprockets. Secure one sprocket.

Apply 2–10 kg (4.4–22.1 lb) of tension with a spring scale to the other sprocket. Measure the chain length as shown.

**SERVICE LIMIT: 195.8 mm (7.71 in)**

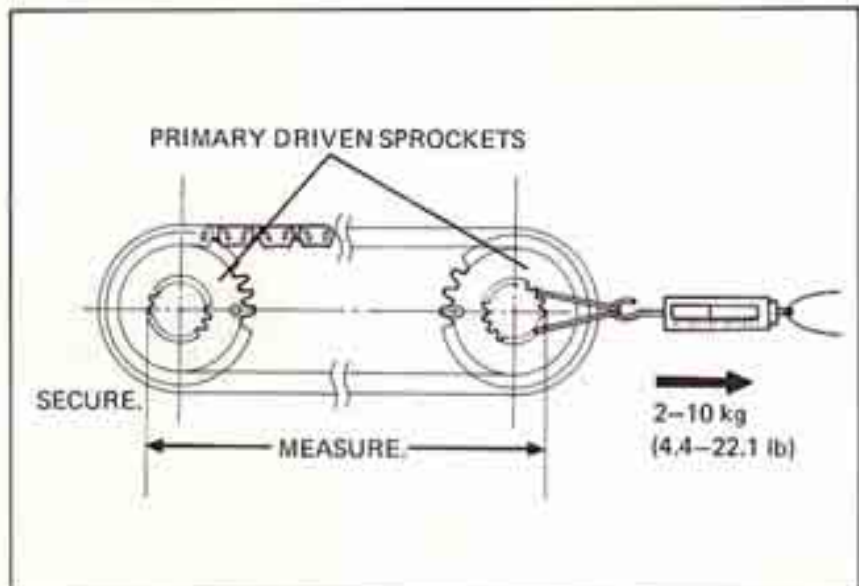
**BEARING INSPECTION****CONNECTING RODS**

Inspect the bearing inserts for damage or separation.

Clean all oil from the bearing inserts and crankpins.

Put a piece of plastigauge on each crankpin, avoiding the oil hole.

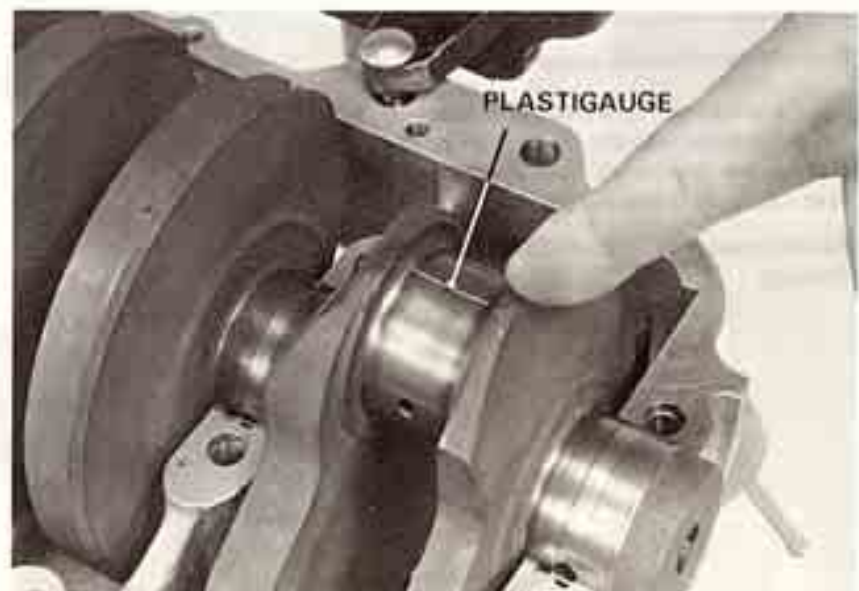



Install the bearing caps and rods on the correct crankpins, and tighten them evenly.

**TORQUE:**

2.8–3.2 kg-m (20–23 ft-lb)

**NOTE**

Do not rotate the crankshaft during inspection.

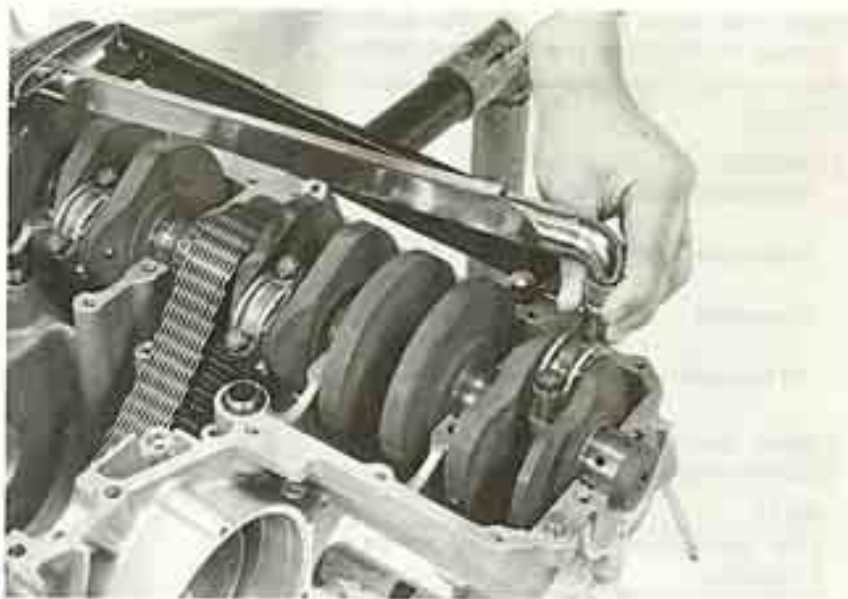

Remove the caps and measure the compressed plastigauge on each crankpin.

**OIL CLEARANCE SERVICE LIMIT:**

0.08 mm (0.003 in)



**MAIN BEARINGS**

Inspect the bearing inserts for damage or separation.

Clean all oil from the bearing inserts and journals.

Put a piece of plastigauge on each journal, avoiding the oil holes.





## CRANKSHAFT/PRIMARY SHAFT

Install the main bearings on the correct journals on the lower crankcase and tighten them evenly in the sequence shown and in 2-3 steps.

### TORQUES:

8 mm bolt (Crankshaft)	2.3-2.7 kg-m (17-20 ft-lb)
8 mm bolt (Crankcase)	2.3-2.7 kg-m (17-20 ft-lb)
6 mm bolt	1.0-1.4 kg-m (7-10 ft-lb)
10 mm bolt	3.3-3.7 kg-m (24-27 ft-lb)

Tighten the upper crankcase bolts to the specified torque, proceeding front to rear.

### NOTE

Do not rotate the crankshaft during inspection.

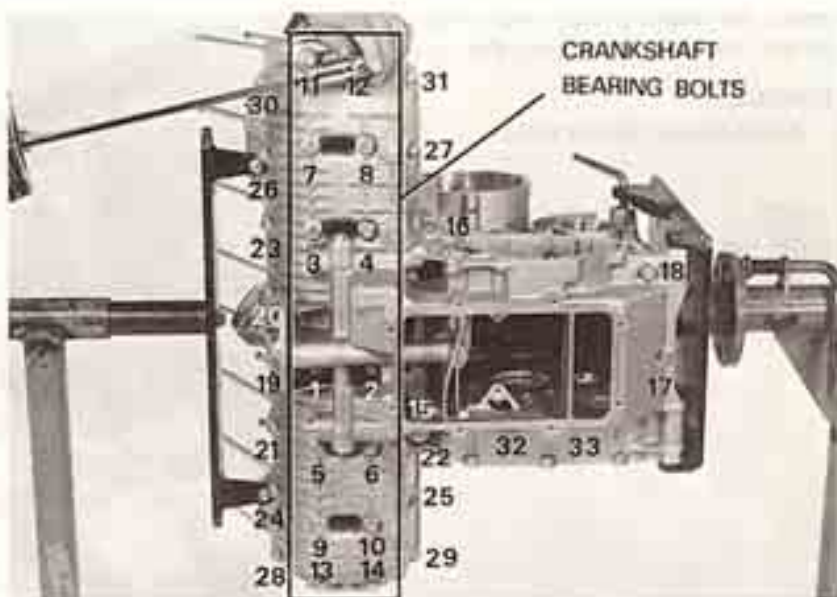

Remove the lower crankcase and measure the compressed plastigauge on each journal.

**OIL CLEARANCE SERVICE LIMIT:**  
0.08 mm (0.003 in)



## BEARING SELECTION

If rod bearing clearance is beyond tolerance, select replacement bearings as follows:

### CONNECTING ROD BEARING INSERTS

Determine and record the corresponding rod I.D. code number.

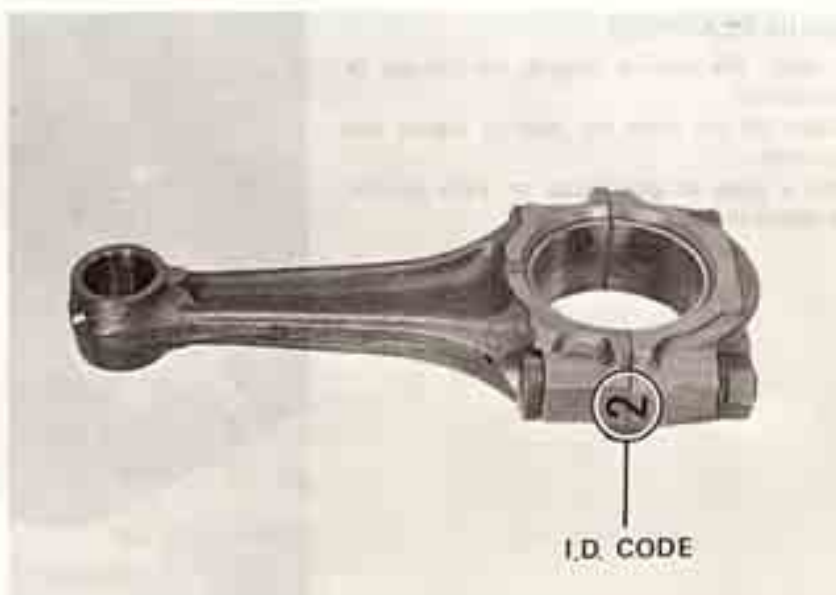





Determine and record the corresponding crankpin O. D. code number (or measure the crankpin O. D.).

### NOTE

The six letters "Ⓟ L-BBCBBB" on the crank weight indicate the code numbers for the crankpin O. D. from left to right; e. g. O. D. code number for the second crankpin from left is B.



Cross reference the crankpin and rod codes to determine the replacement bearing color.

		CRANKPIN O. D. CODE NO.			
		A	B	C	
CONNECTING ROD I. D. CODE NO.	1	39.000- 39.008 mm	E (Yellow)	D (Green)	C (Brown)
	2	39.008- 39.016 mm	D (Green)	C (Brown)	B (Black)
	3	39.016- 39.024 mm	C (Brown)	B (Black)	A (Blue)

### BEARING INSERT THICKNESS:

A (Blue)	: 1.502-1.506 mm (0.0591-0.0593 in)
B (Black)	: 1.498-1.502 mm (0.0590-0.0591 in)
C (Brown)	: 1.494-1.498 mm (0.0588-0.0590 in)
D (Green)	: 1.490-1.494 mm (0.0587-0.0588 in)
E (Yellow)	: 1.486-1.490 mm (0.0585-0.0587 in)

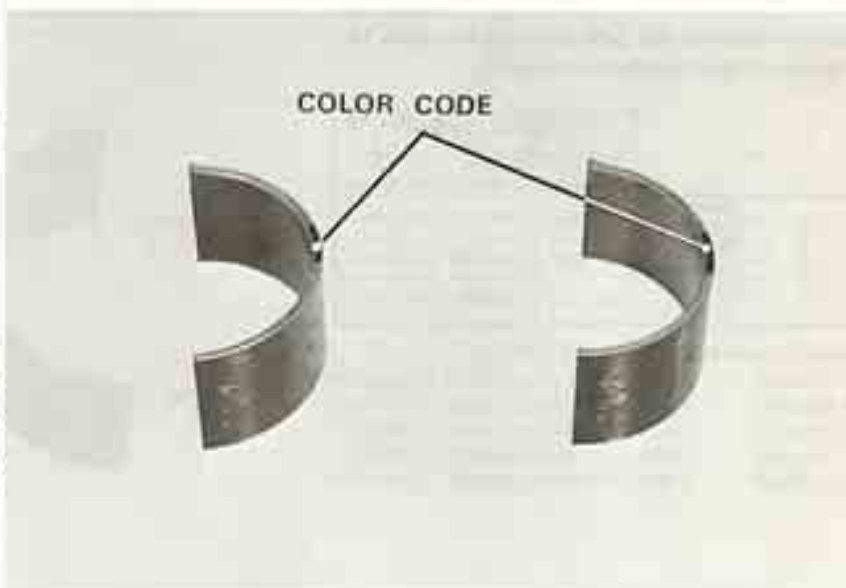

### MAIN BEARING

Determine and record crankcase I. D. code numbers.

### NOTE

The seven numbers "I III II II III I II" on the upper left crankcase indicate the code numbers for the main journal I. D. from left to right; e. g. I. D. code number for the fifth main journal from left to right is III.



**CRANKSHAFT/PRIMARY SHAFT**

Determine and record the corresponding main journal O. D. code letters (or measure the main journal O. D.).

**NOTE**

The seven numbers "① L-3322232" on the crank weight indicate the code numbers for the main journal O. D. from left to right; e. g. O.D. code number for the third main journal from left to right is 2.



Cross reference the case and journal codes to determine the replacement bearing.

CASE I. D. CODE NO.		MAIN JOURNAL O. D. CODE NO.		
		1	2	3
I	29.000- 29.008 mm	D (Yellow)	C (Green)	B (Brown)
	29.008- 29.016 mm	C (Green)	B (Brown)	A (Black)
III	29.016- 29.024 mm	B (Brown)	A (Black)	AA (Blue)

**MAIN BEARING INSERT THICKNESS:**

AA (Blue)	: 1.502-1.506 mm (0.0591-0.0593 in)
A (Black)	: 1.498-1.502 mm (0.0590-0.0591 in)
B (Brown)	: 1.494-1.498 mm (0.0588-0.0590 in)
C (Green)	: 1.490-1.494 mm (0.0587-0.0588 in)
D (Yellow)	: 1.486-1.490 mm (0.0585-0.0587 in)

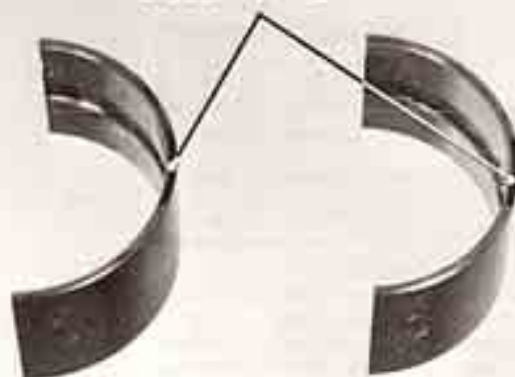
**COLOR CODE****CONNECTING ROD INSTALLATION**

Install the main bearings into the upper crankcase.

Apply molybdenum disulfide grease to the upper and lower main bearings.

Install the crankshaft with the cam chain and primary chain.





Before installing the connecting rods, make sure that the weight code combination is correct:

Factory set code	Available code
A	→ B
B	→ B
C	→ D
D	→ D
E	→ D
F	→ F
G	→ F



Align the hole in the bearing insert with the hole in the connecting rod.



Install the connecting rod and cap bearing inserts.  
Apply molybdenum disulfide grease to the connecting rod bearings.

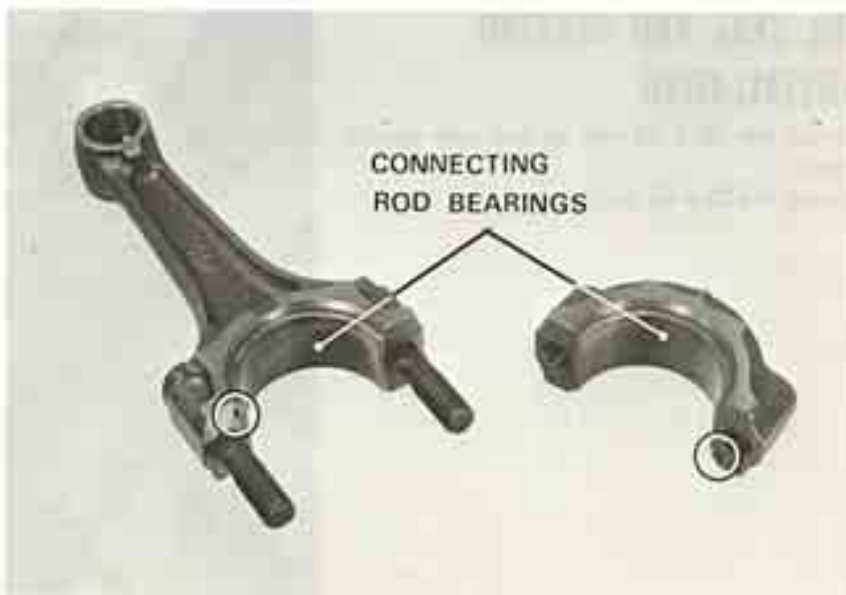





**CRANKSHAFT/PRIMARY SHAFT**

Install the connecting rods and bearing caps.

**NOTE**

- Be sure connecting rods are installed in their correct position and the oil holes point to the rear.
- Cross reference the rod and cap I. D. codes to insure original assembly.



Torque the connecting rod bearing cap bolts.

**TORQUE:**

2.8-3.2 kg-m (20-23 ft-lb)

**NOTE**

- Tighten the rod bearing cap bolts in two or more steps.
- After tightening the bolts, check that the rod moves freely without binding.



**OIL SEAL AND BEARING INSTALLATION**

Install the 25 x 38 mm oil seal with special tools.

Install the 25 x 52 mm oil seal.





On and after Eng. No. CB1E-2020729

Install the primary chain over the primary driven sprocket.

Make sure that the driven sprocket index mark aligns with the bearing boss mark as shown.

### NOTE

One primary driven sprocket slot aligns with an index mark on the sprocket's other side. This slot can also be used as a reference.

Install the ring nut, thrust spring and starter clutch.

### NOTE

Do not move the driven sprocket from the correct position when installing the starter clutch and thrust spring. To facilitate operation, screw the ring nut onto the driven sprocket 1-2 turns.

Install the primary shaft assembly. Make sure that the recess in the primary shaft is positioned 90° from the crankcase mating surface, and the bearing holder is in position.

### CAUTION

Do not damage the oil seals when installing the primary shaft.

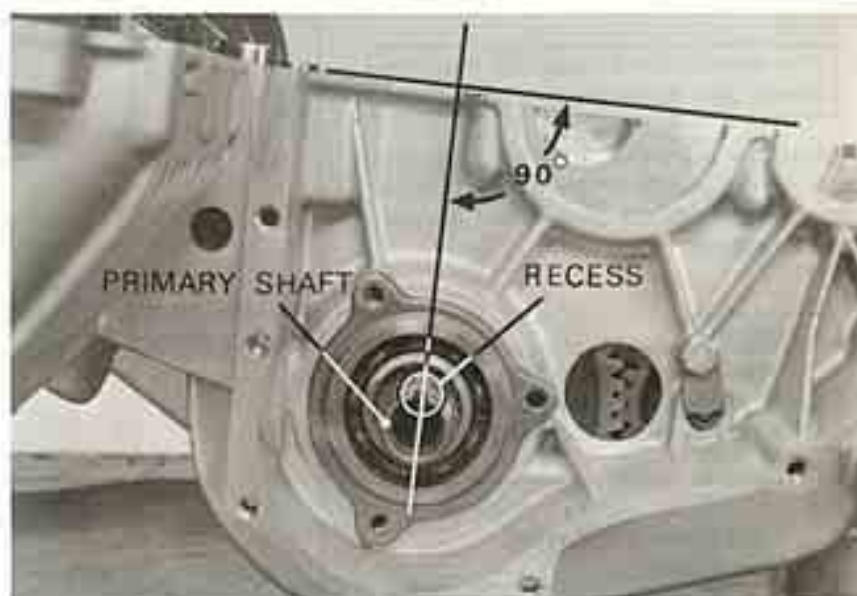
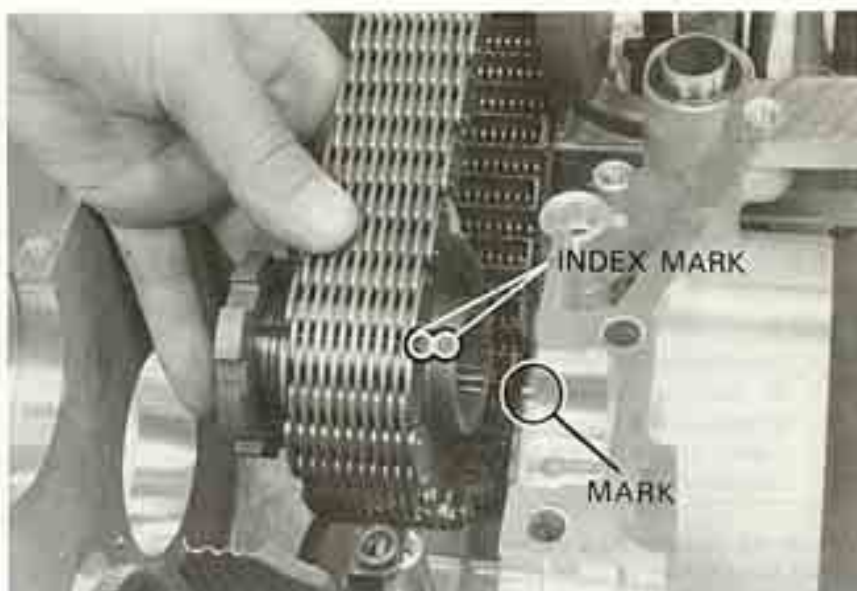

On and before Eng. No. CB1E-2020728

Make certain that the primary shaft recess aligns with the driven sprocket index mark (page 12-16).

On and after Eng. No. CB1E-2020729

Make certain that the primary shaft recess aligns with the sprocket index mark and corresponding slot. The shaft recess, and sprocket slot/mark should align with the bearing boss mark as shown.

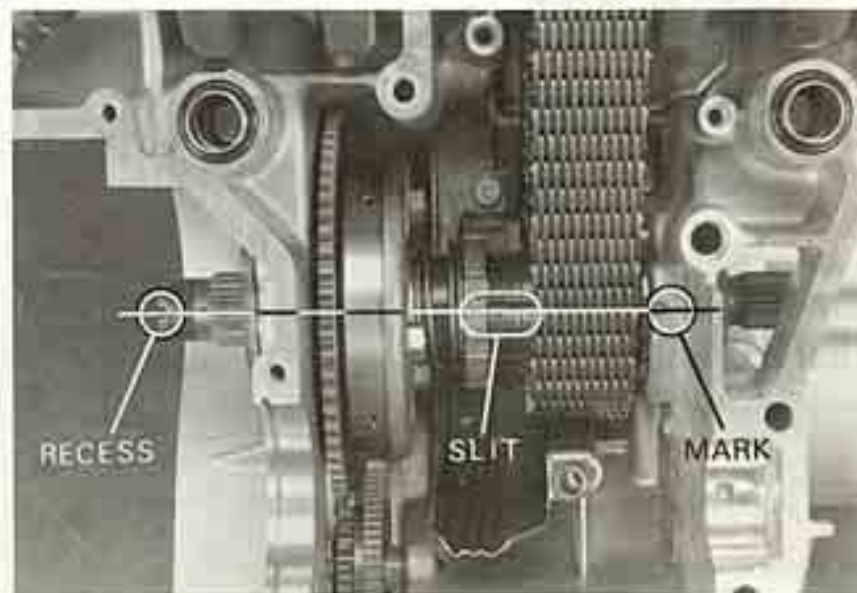





**CRANKSHAFT/PRIMARY SHAFT**

Tighten the primary shaft bearing holder bolts securely.

On and after Eng. No. CB1E-2020729

Hold the primary shaft with the special tool "PRIMARY SHAFT HOLDER". Tighten the collet ring nut with the special tool "55 mm PIN SPANNER."

**NOTE**

- The ring nut has left-hand threads.
- Be certain the sprocket and nut threads do not have any burrs.
- Lightly oil the threads before tightening the nut.

Attach the spanner to a 350-500 mm (14-20 in) beam torque wrench.

**NOTE**

The wrench size is measured from the handle pivot to the drive center.

Tighten the collet ring nut to obtain a wrench scale reading of 4.2-4.5 kg-m (30-35 ft-lb). This will provide the desired torque value at the pin spanner.

**CAUTION**

*If other than a beam torque wrench is used, consult the manufacture's operating instructions regarding adapter usage.*

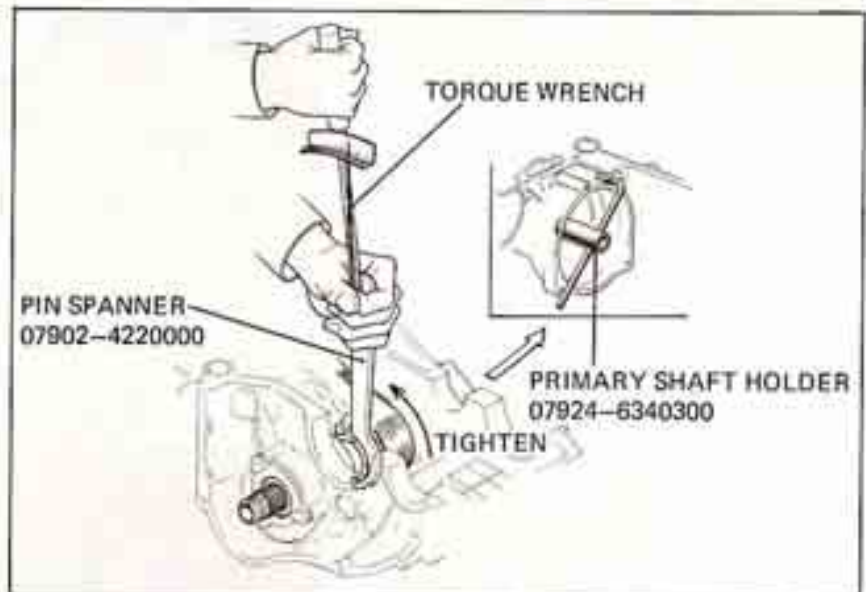
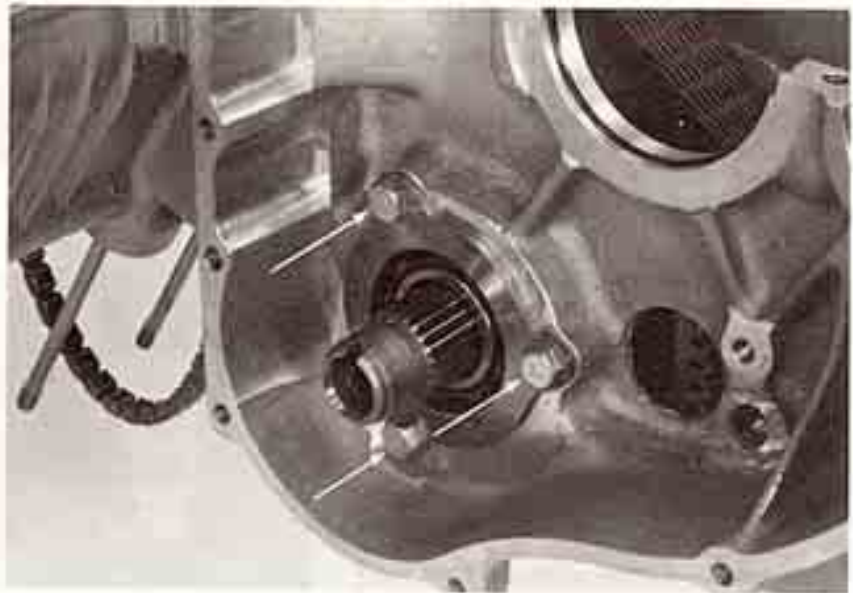

**EFFECTIVE LENGTH OF ASSEMBLY**

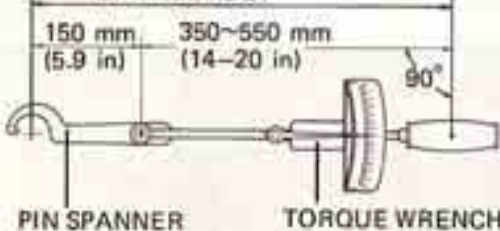

**STARTER IDLE GEAR INSTALLATION**

Install the starter idle gear as shown.

**NOTE**

Be sure to install the wave washer.

Install the idle gear shaft holder.

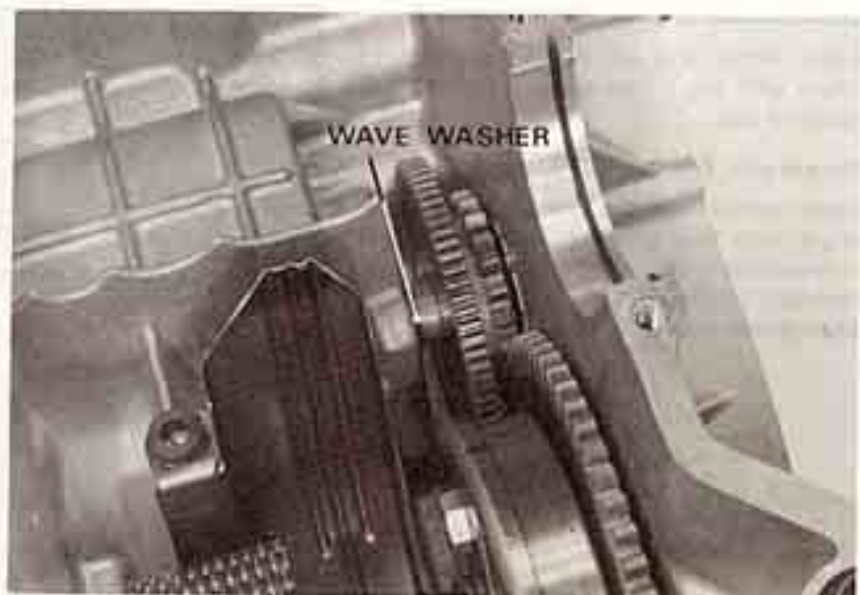





## PRIMARY CHAIN TENSIONER ASSEMBLY

Before installing the oil pipe, check the holes for blockage.

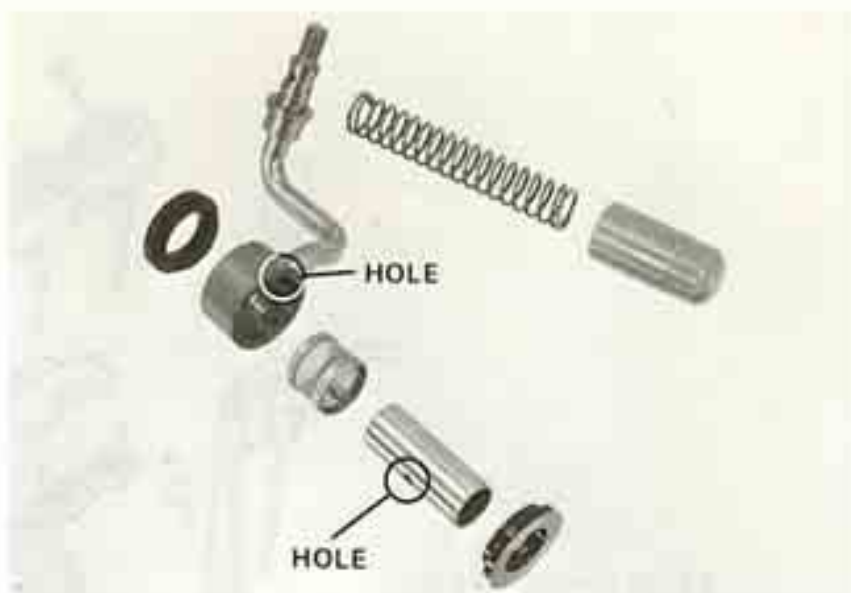

Assemble the primary chain tensioner as shown.  
Tighten the nut loosely.



Insert the oil pipe into oil opening.  
Tighten the nut securely.

Install the oil supply nozzle.  
Install the transmission (Section 11).  
Assemble the crankcase (Section 10).





**FRONT WHEEL/SUSPENSION**

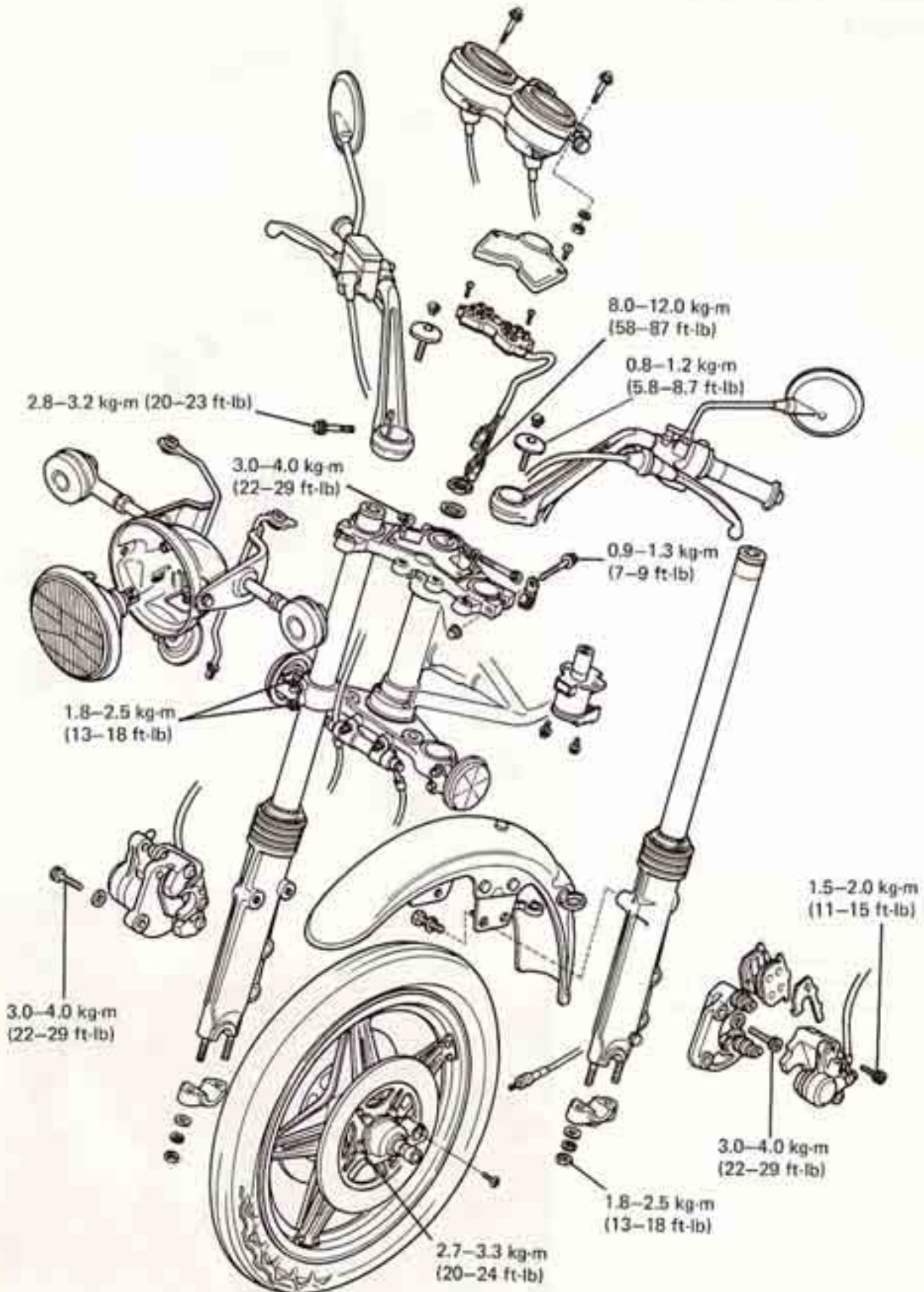



SERVICE INFORMATION	13-1
TROUBLESHOOTING	13-2
HEADLIGHT	13-3
INSTRUMENTS	13-6
HANDLEBAR SWITCH/HANDLEBARS	13-8
FRONT WHEEL	13-14
FRONT FORK	13-19
STEERING STEM	13-25

## SERVICE INFORMATION

### WORKING PRACTICE

The front wheel uses a tubeless tire. For tubeless tire repairs, refer to the TUBELESS TIRE MANUAL, code No. 6141550.

Do not remove rivets, nuts and pins from the rim, spoke plate and hub.

Never ride on the rim or try to bend the wheel.

Avoid damaging the aluminum alloy rim.

### SPECIAL TOOLS

#### Special Tools

Steering Stem Socket	07916-3710100
Hollow Set Wrench (6mm)	07917-3230000
Bearing Race Remover	07946-3710500
Steering Stem Driver	07946-3710600
Bearing Driver Attachment	07946-3710700

#### Common Tools

Retainer Wrench C	07710-0010300
Retainer Wrench Body	07710-0010400
Bearing Driver Outer (42x47mm)	07746-0010300
Bearing Driver Pilot (15mm)	07746-0040300
Front Fork Oil Seal Driver Body	07747-0010100
Front Fork Oil Seal Attachment (E)	07747-0010600
Lock Nut Wrench Socket (26 x 30)	07716-0020202
Bearing Driver Handle (A)	07749-0010000
Extension Bar	07716-0020500

### TORQUE VALUES

Front brake disc	2.7-3.3 kg-m (20-24 ft-lb)
Front axle nut	5.5-6.5 kg-m (40-47 ft-lb)
Front caliper bracket	3.0-4.0 kg-m (22-29 ft-lb)
Front caliper	1.5-2.0 kg-m (11-15 ft-lb)
Front axle holder nut	1.8-2.5 kg-m (13-18 ft-lb)
Front fork bolt	2.0-3.0 kg-m (15-22 ft-lb)
Handlebar mounting bolt	2.8-3.2 kg-m (20-23 ft-lb)
Fork bottom bridge	1.8-2.5 kg-m (13-18 ft-lb)
Fork top bridge	0.9-1.3 kg-m (7-9 ft-lb)
Head top thread	0.8-1.2 kg-m (5.8-8.7 ft-lb)
Steering stem nut	8.0-12.0 kg-m (58-87 ft-lb)
Fork top cap bolt	0.8-1.2 kg-m (5.8-8.7 ft-lb)

### SPECIFICATIONS

		STANDARD	SERVICE LIMIT
Axle shaft runout		—	0.2 mm (0.008 in)
Front wheel rim runout	Radial	—	2.0 mm (0.08 in)
	Axial	—	2.0 mm (0.08 in)
Fork spring free length		562.0 mm (22.1 in)	552.0 mm (21.7 in)
Tube bend		—	0.2 mm (0.008 in)
Front fork slider I.D.		35.04 -35.10 mm (1.3796-1.3820 in)	35.25 mm (1.388 in)
New type-with guide		35.03 -35.08 mm (1.3792-1.3812 in)	35.15 mm (1.384 in)
Front fork tube O.D.		34.96 -34.90 mm (1.3764-1.3740 in)	34.90 mm (1.374 in)





## TROUBLE SHOOTING

### Hard Steering

1. Steering stem nut too tight
2. Faulty steering stem bearings
3. Damaged steering stem bearings
4. Insufficient tire pressure

### Steers to One Side or Does Not Track Straight

1. Unevenly adjusted right and left shock absorbers
2. Bent front forks
3. Bent front axle; wheel installed incorrectly

### Front Wheel Wobbling

1. Distorted rim
2. Worn front wheel bearing
3. Faulty tire
4. Axle not tightened properly

### Soft Suspension

1. Weak fork spring
2. Insufficient fluid in front forks

### Hard Suspension

1. Incorrect fluid weight in front forks

### Front Suspension Noise

1. Slider binding
2. Insufficient fluid in forks
3. Loose front fork fasteners



### HEADLIGHT

#### HEADLIGHT CASE REMOVAL

Remove the headlight and disconnect all wires at their couplers and connectors.

To remove the headlight case, unscrew the headlight case mounts.

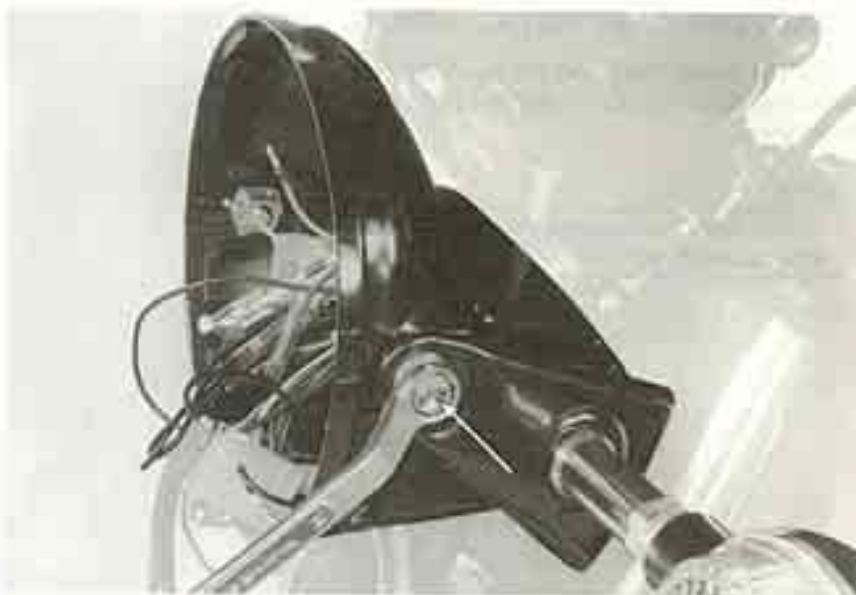

#### HEADLIGHT DISASSEMBLY/ ASSEMBLY

Remove the bulb cover, set ring and bulb. Remove the retaining lock pins, screws and horizontal adjusting screw from the rim.

Remove the two headlight unit retaining screws, and headlight unit.

Assembly is essentially the reverse of disassembly.



After assembly, adjust headlight beam (Page 3-19).

#### NOTE

Do not touch the with your fingers.

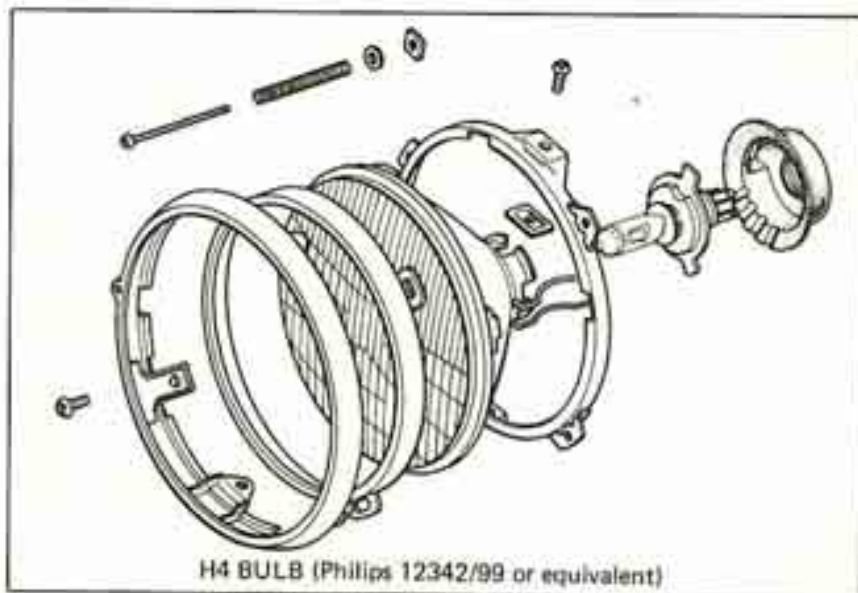



**HEADLIGHT CASE INSTALLATION**

Align the punch marks on the headlight case with the punch marks on the headlight case brackets.

**NOTE**

Check each component for operation after assembling.

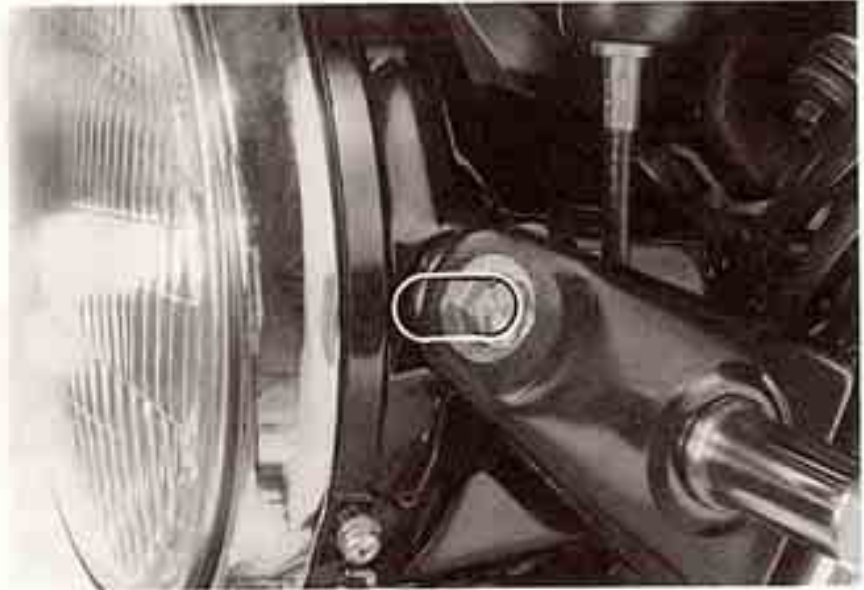

**WIRING CONNECTION IN HEADLIGHT CASE**

Route the wires into the headlight case through the headlight case hole.

- LOWER HOLE:** Main wire harness
- UPPER RIGHT HOLE:** Right turn signal wires  
Right handlebar switch wires
- UPPER LEFT HOLE:** Fuse holder wires  
Left handlebar switch wires  
Left turn signal wires



Connect the color-coded wires and couplers. Secure each coupler in its correct holder in the headlight case.

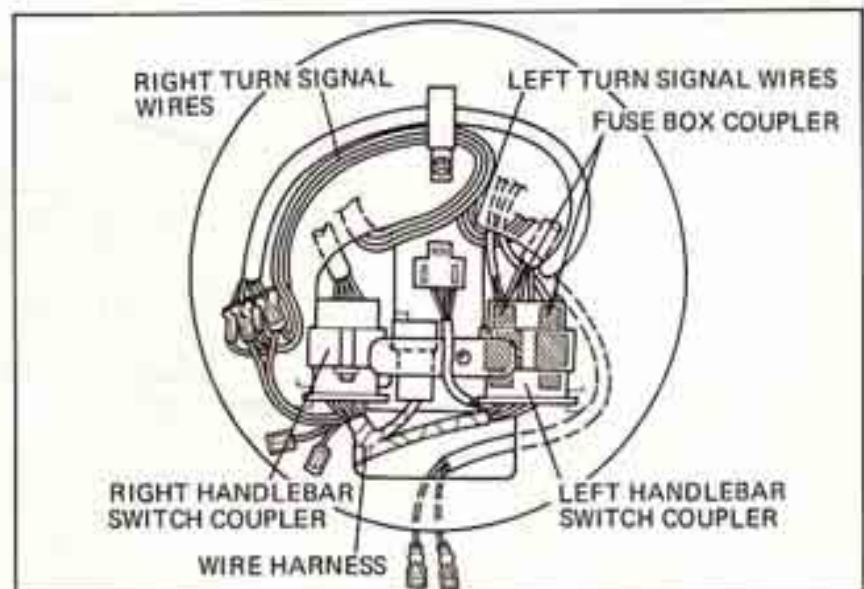





**HEADLIGHT CASE BRACKET  
DISASSEMBLY/ASSEMBLY**

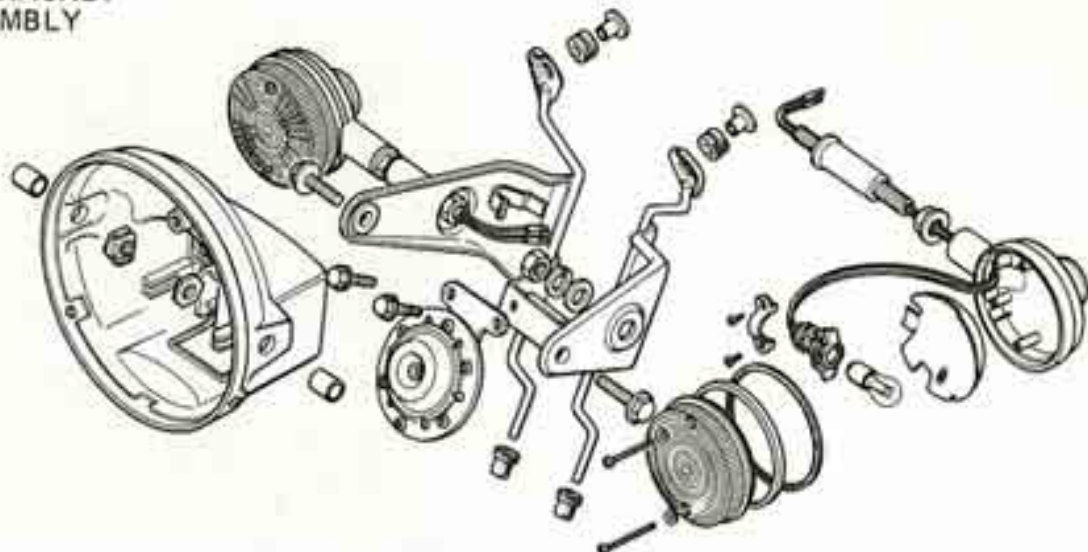

Remove the headlight and disconnect all wires and wire couplers inside the case. Disconnect the brake hose from the front brake master cylinder.

**NOTE**

Avoid spilling fluid on painted surfaces. Place a rag over the fuel tank whenever the brake hose is disconnected.



Install the turn signals parallel with the ground. Tighten the lock nuts securely.





## INSTRUMENTS

### CLUSTER DISASSEMBLY

Remove the speedometer and tachometer cables from the instruments.



Remove the two instrument mounting bolts and separate the coupler from the instrument cluster.  
Remove the cluster.



Remove the lower instrument case by removing four bolts.

#### **WARNING**

*Do not leave the instrument upside down for a long time.*





Remove the instrument lamps and speedometer and tachometer by pushing them out. Check the meter cable if the needle swings abnormally.

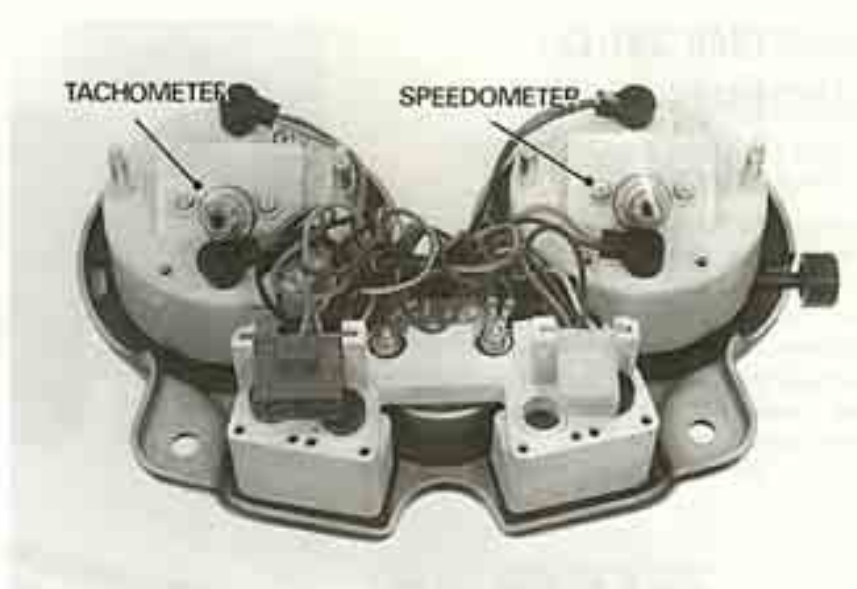

Remove the voltmeter.

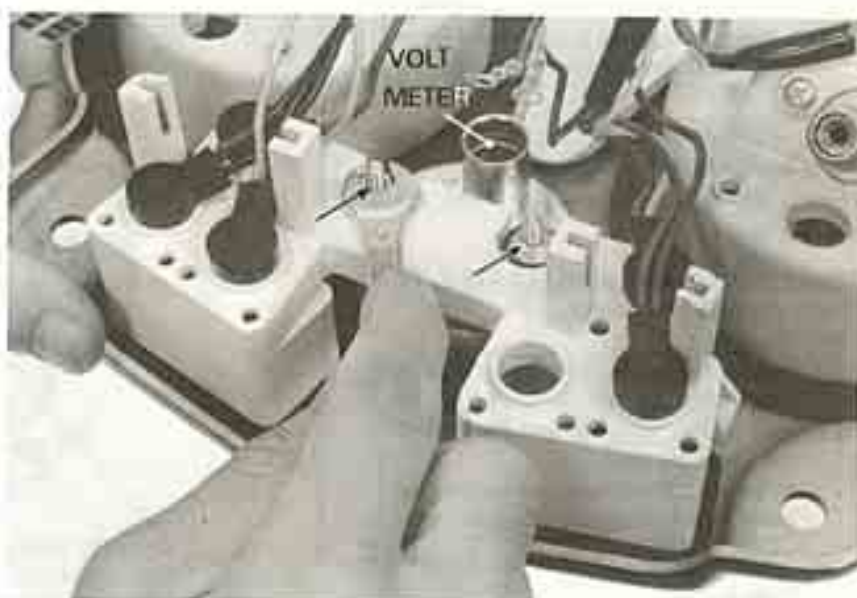

### CLUSTER ASSEMBLY

Connect the lamp wires color-to-color.

After installing a new bulb, check for continuity. If the bulb does not light, inspect the wiring for open or short circuits.

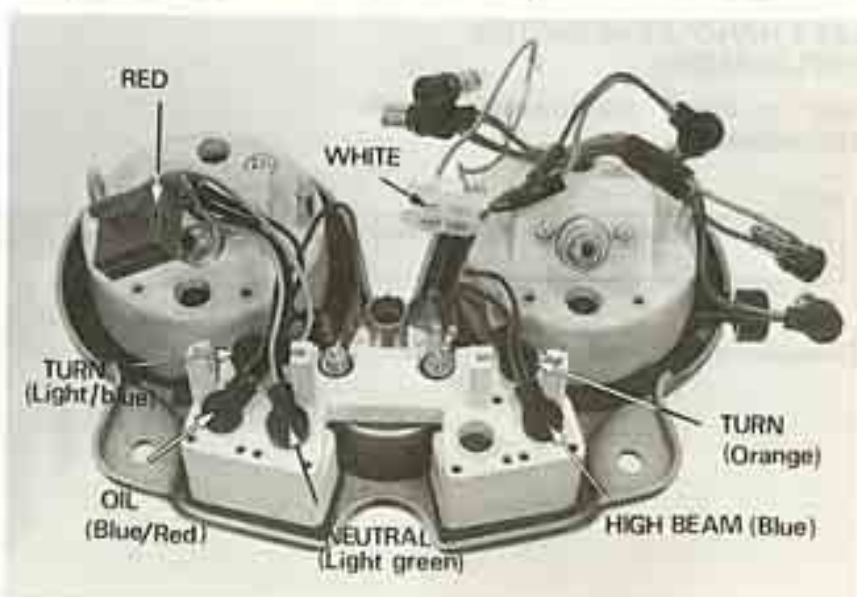





## HANDLEBAR SWITCH/ HANDLEBARS

### RIGHT HANDLEBAR SWITCH REPLACEMENT

Remove the fuel tank.  
 Remove the screws holding the upper and lower switch housings.  
 Remove the throttle cables.  
 Disconnect the front brakelight switch.  
 Remove the headlight from the headlight case and disconnect the right handlebar switch wire coupler.  
 Remove the switch wires from the headlight case.

#### NOTE

Connect a string to the switch cord and then remove the cord leaving the string. This string is used as a draw cord when routing the wiring of a new switch.

Install a new switch aligning its locating pin in the handlebar.

Tighten the forward screw first, then tighten the rear screw.

**TORQUE: 0.10–0.15 kg-m (8.4–13.0 in-lb)**  
 Check the switch operation.

#### NOTE

- Before tightening the throttle cable lock nut, turn the handlebar all the way to the right and pull the throttle cables to the right.
- Make sure there is clearance between the switch housing and throttle grip.

After installing, adjust throttle cable free play. (Page 3–6)

### LEFT HANDLEBAR SWITCH REPLACEMENT

Refer to **RIGHT HANDLEBAR SWITCH REPLACEMENT**.

#### NOTE

It is not necessary to remove the fuel tank.

Disconnect the left handlebar switch wires.

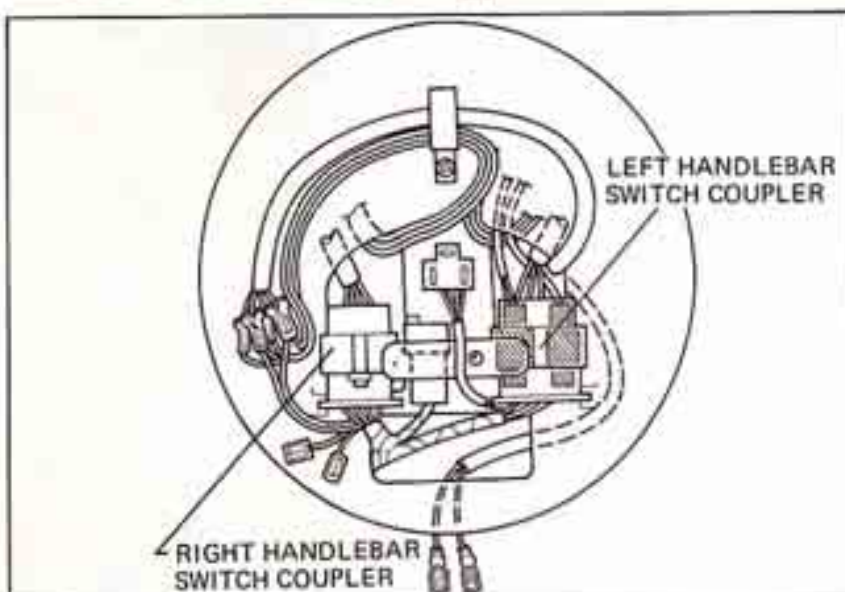



### RIGHT HANDLEBAR REMOVAL

Loosen the three screws attaching the throttle grip/switch housing. Remove the right handlebar switch wires from the handlebar.

Remove the brake master cylinder.

#### CAUTION

*Secure the brake cylinder in an upright position to prevent the fluid from leaking and damaging the paint and to prevent air from entering the brake system.*

#### NOTE

Do not loosen the brake hose unless necessary.

Remove the handlebar mounting bolts. Remove the handlebar. Remove the throttle grip and switch assembly.

### RIGHT HANDLEBAR INSTALLATION

Attach the handlebar to the front fork tube, inserting the locating lug into the cut-out of the fork top bridge.

#### NOTE

Before installing the handlebar mounting bolt, coat the bolt threads with oil.

Coat the throttle grip area of handlebar with grease.

Install the throttle grip switch housing and throttle cables.

#### TORQUE:

Switch housing: 0.10–0.15 kg-m  
(8.4–13.0 in-lb)

Throttle cable lock nut:  
0.2–0.3 kg-m  
(17.4–26.0 in-lb)

#### NOTE

- Before tightening the throttle cable lock nut, turn the handlebar all the way to the right and pull the throttle cables to the right.
- Make sure there is clearance between the switch housing and throttle grip.

Check throttle operation in all steering position (Page 3-4).

Install the master cylinder on the handlebar with the end of the holder aligned with the punch mark and wire relief facing down.

Tighten the upper screw first, then tighten the lower screw.

After assembly, check that the brake lever does not touch the switch housing when it is pulled in.







### LEFT HANDLEBAR REMOVAL

See **RIGHT HANDLEBAR REMOVAL/INSTALLATION**.

- Remove the left grip.
- Remove the left handlebar switch assembly.
- Loosen the clutch lever bracket bolt.
- Remove the clutch lever assembly.
- Remove the handlebar mounting bolt and handlebar.



### LEFT HANDLEBAR INSTALLATION

Attach the handlebar to the front fork tube, inserting the locating lug into the cut-out of the fork top bridge.

#### NOTE

Before installing the handlebar mounting bolt, coat the bolt threads with oil.

Install the left handlebar switch assembly. Tighten the forward screw first, then tighten the rear screw.

**TORQUE: 0.10–0.15 kg-m (8.4–13.0 in-lb)**

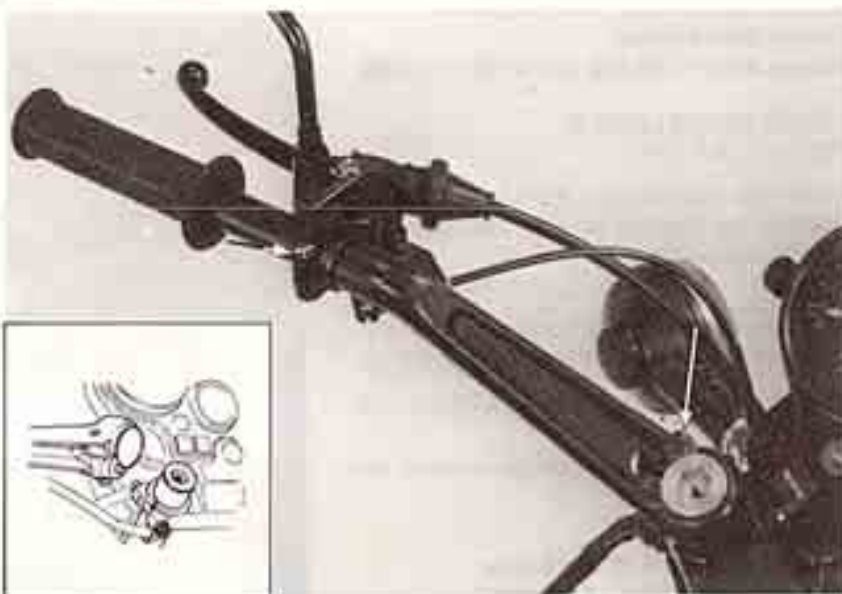

- Install the clutch lever assembly.
- Install the handle lever bracket with the split aligned with the punch mark on the handlebar.
- Install the left grip.

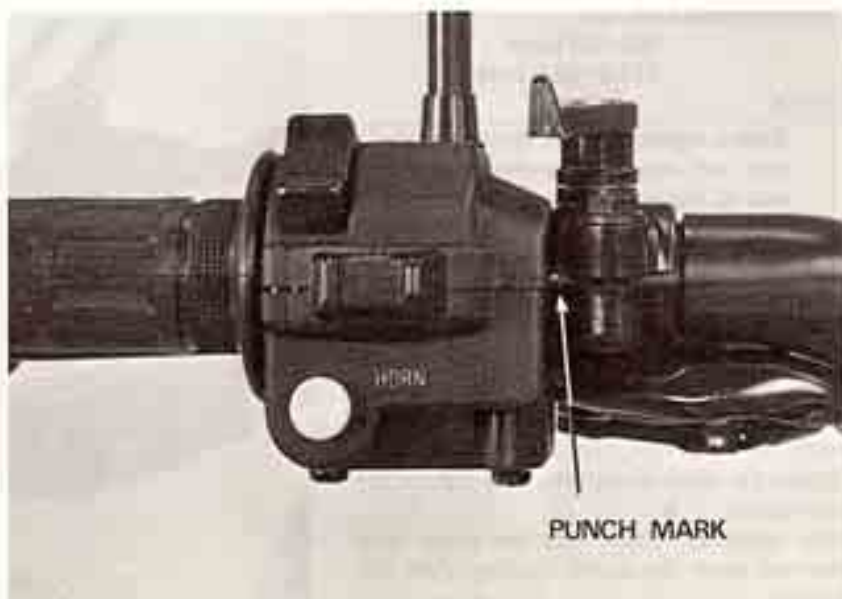





### IGNITION SWITCH REPLACEMENT

Remove the two bolts holding the instrument cluster.

Remove the bolt holding the ignition switch and disconnect the wire harness coupler.



### FUSE HOLDER REPLACEMENT

Remove the fuse cover.

Unscrew the screws holding the fuse holder.

Remove the headlight.

Disconnect the wire coupler.

Remove the fuse holder.



#### NOTE

Before disconnecting the holder wires, tie a string to them. This string can be used as a draw cord when installing a new holder.

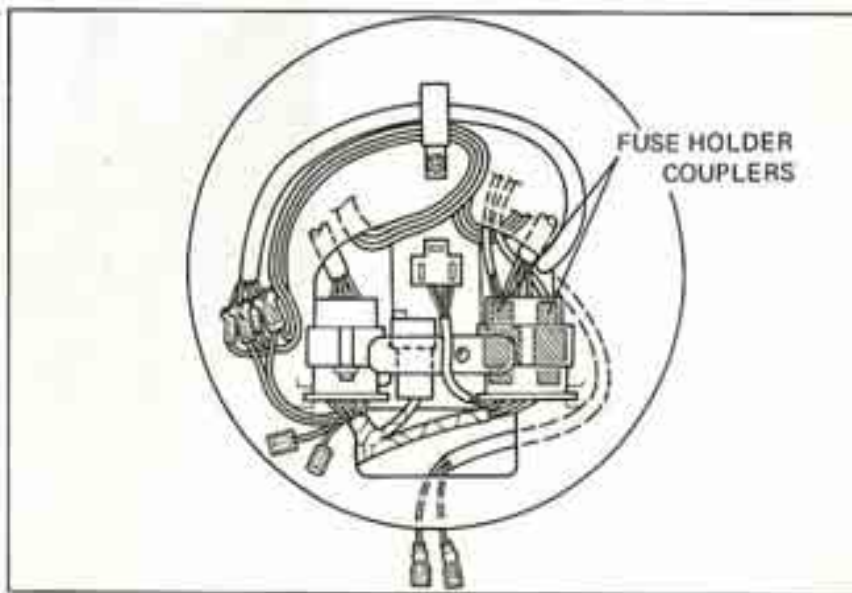

**CHOKE CABLE REPLACEMENT**

Remove the fuel tank.  
Disconnect the choke cable from the lower  
choke cable bracket.  
Remove the cable end from the choke lever,

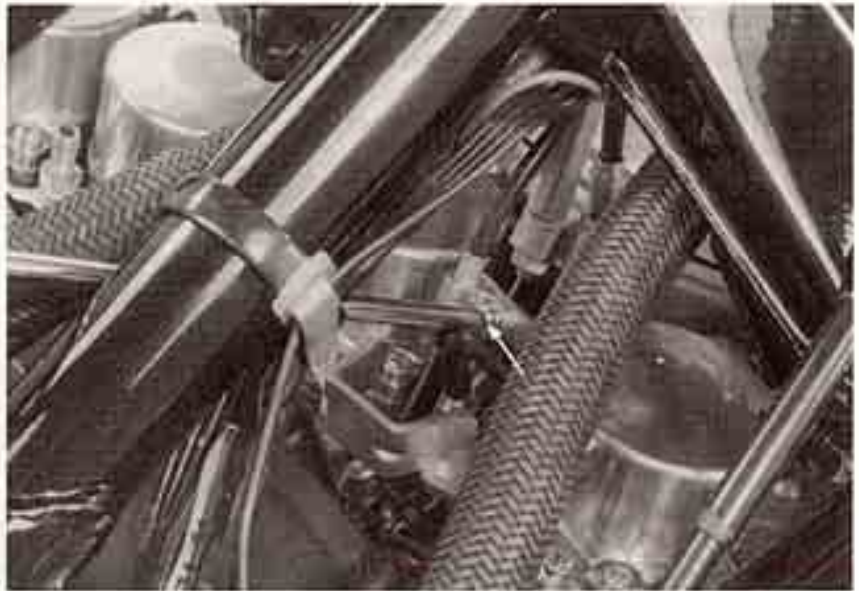

Remove the choke cable from the choke lever  
on the handlebar.

**NOTE**

Before removing the cable, tie a string  
to the cable end. This string can be  
used as a draw cord when installing a  
new choke cable.

**CLUTCH CABLE REPLACEMENT**

Remove the fuel tank.  
Remove the clutch cable from the lever.







Loosen the lock nut on the engine and remove the clutch cable from the clutch lever.

### NOTE

Before removing the clutch cable, connect a string to the end of the cable so that a new cable can be installed easily by using this string as a draw cord.

Adjust the clutch cable after replacement (Page 3-19).



### THROTTLE CABLE REPLACEMENT

Remove the fuel tank.  
Remove the right handlebar switch/throttle housing.  
Remove the throttle cables from the throttle pipes.



Tilt the engine forward (Page 5-1).  
Remove the throttle cables from the carburetors.

Adjust throttle cable free play (Page 3-6).







## FRONT WHEEL

### FRONT WHEEL REMOVAL

Remove the speedometer cable set screw and the speedometer cable.

Remove the right and left side caliper assemblies by loosening the allen bolts.

#### NOTE

Do not operate the front brake lever after removing the front wheel. To do so will cause difficulty in fitting the brake disc between the brake pads.

Remove the right and left axle holders.

Remove either front brake caliper.  
 Jack up the engine until the forks clear the front axle and remove the front wheel.

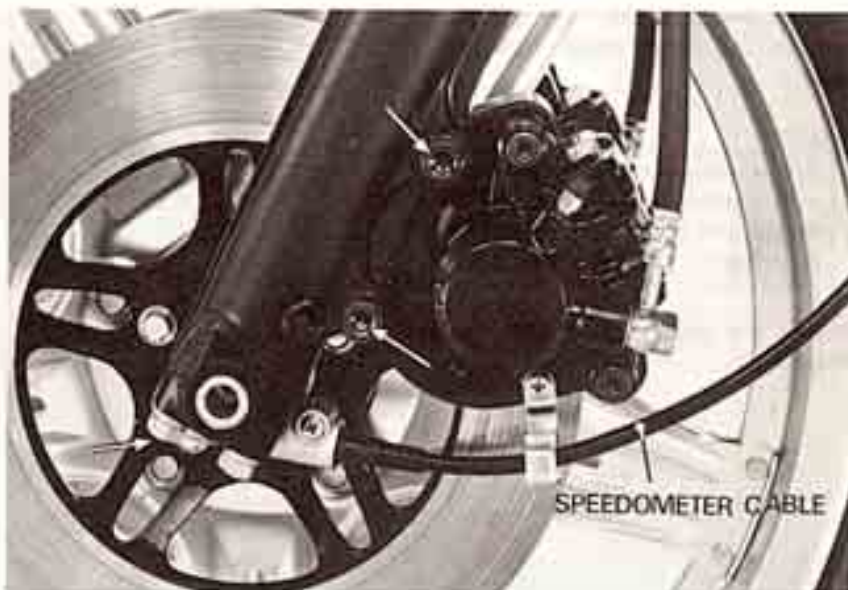

### FRONT WHEEL DISASSEMBLY

Remove the axle nut, speedometer gear box, axle and collar.

Remove five bolts and discs.





Remove the retainer.  
Remove the bearings and the distance collar from the hub.

### NOTE

If the bearings are removed, they should be replaced with new ones.

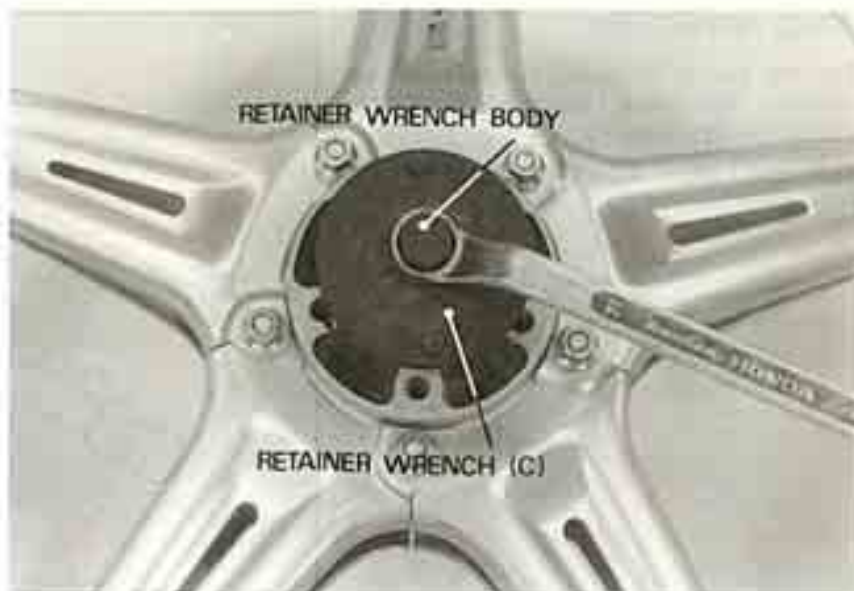

### FRONT WHEEL INSPECTION

#### WHEEL BEARING:

Check wheel bearing play by placing the wheel in a truing stand and spinning the wheel by hand. Replace the bearings with new ones if they are noisy or have excessive play.

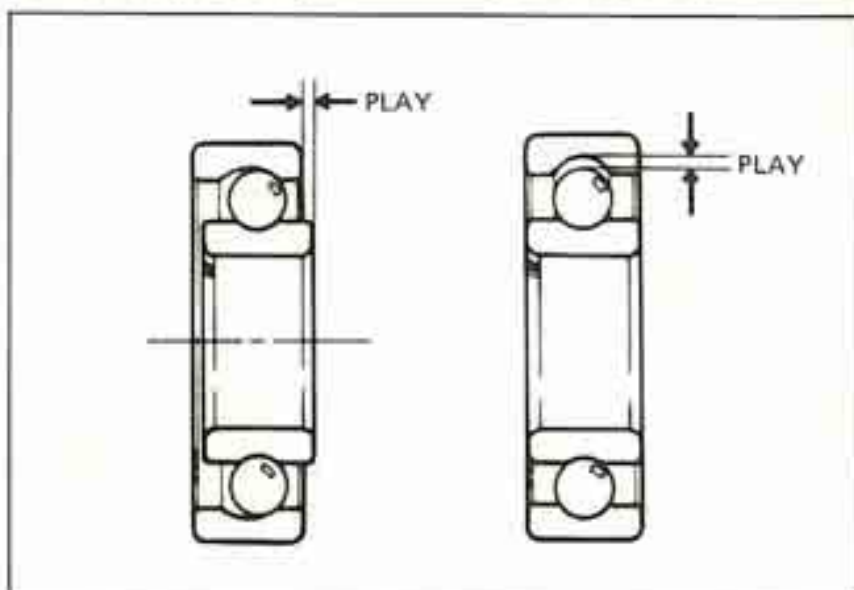

#### WHEEL INSPECTION

Check the rim runout by placing the wheel in a truing stand. Spin the wheel slowly and read the runout using a dial indicator gauge.

#### SERVICE LIMITS:

**RADIAL RUNOUT:** 2.0 mm (0.08 in)

**AXIAL RUNOUT:** 2.0 mm (0.08 in)

### NOTE

The COMSTAT WHEEL cannot be repaired and must be replaced with a new one if the service limits are exceeded.

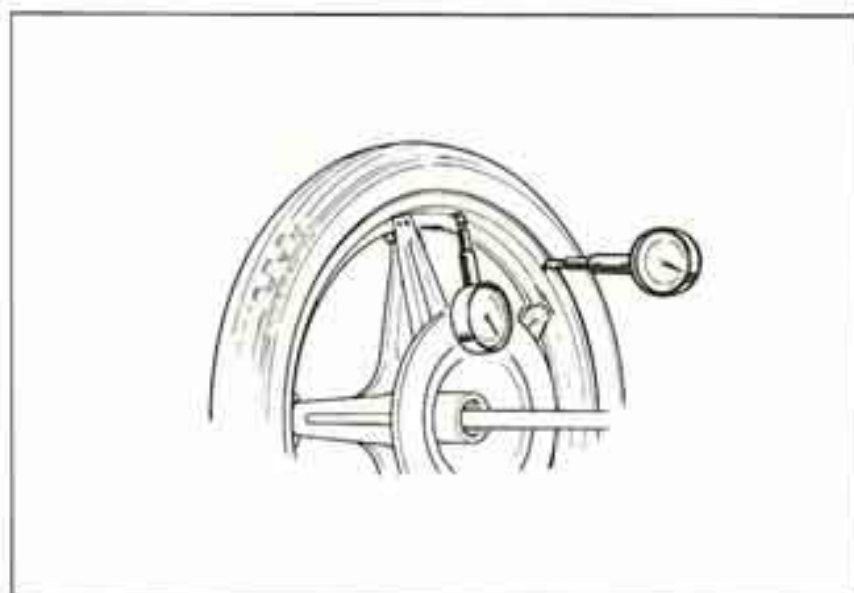



**FRONT WHEEL/SUSPENSION**

**AXLE INSPECTION**

Set the axle in V blocks and measure the runout. The actual runout is 1/2 of TIR (Total Indicator Reading).

**SERVICE LIMIT: 0.2 mm (0.008 in)**

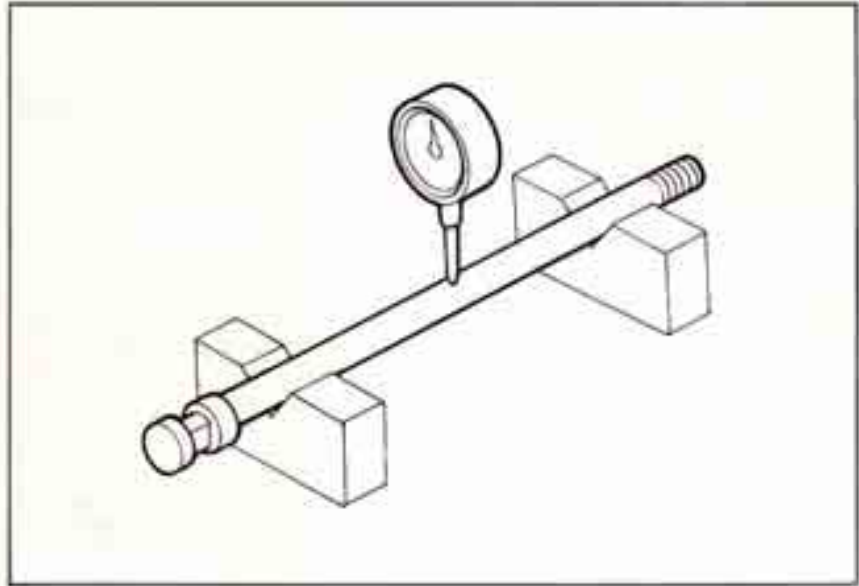

**FRONT WHEEL ASSEMBLY**

5.5–6.5 kg-m  
(40–47 ft-lb)

**GREASE**

BEARING RETAINER

**WARNING**

Do not get grease on the brake disc.

2.7–3.3 kg-m  
(20–24 ft-lb)

**GREASE**

**NOTE**

- The COMSTAR wheel has no rim band.
- The front wheel uses a tubeless tire. For tubeless tire repair, refer to the TUBELESS TIRE MANUAL (Code No. 6141550).





Pack all bearing cavities with grease.  
Drive in the right bearing first.  
Press the distance collar into place.

### NOTE

Be certain the distance collar is in position before installing the bearings.

Drive in the left bearing.

### NOTE

- Drive the bearing squarely.
- Drive the bearing into position, making sure that it is fully seated and that the sealed side is facing out.

BEARING DRIVER HANDLE (A)  
BEARING DRIVER OUTER (42 x 47 mm)  
BEARING DRIVER PILOT (15 mm)

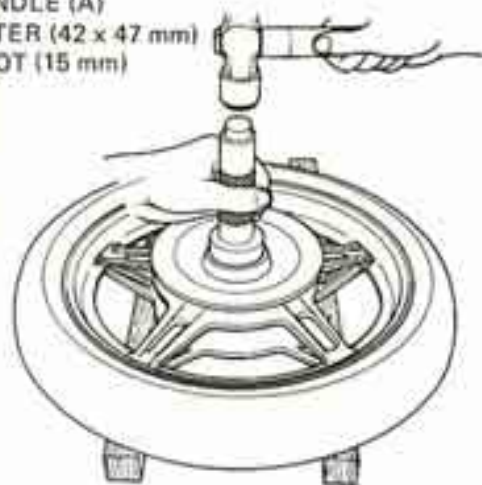

Install the bearing retainer with the tool used to remove it.

### NOTE

Inspect the retainer. If the threads are damaged, it should be replaced.

Install the seal and the bearing retainer and peen the edge of the retainer.

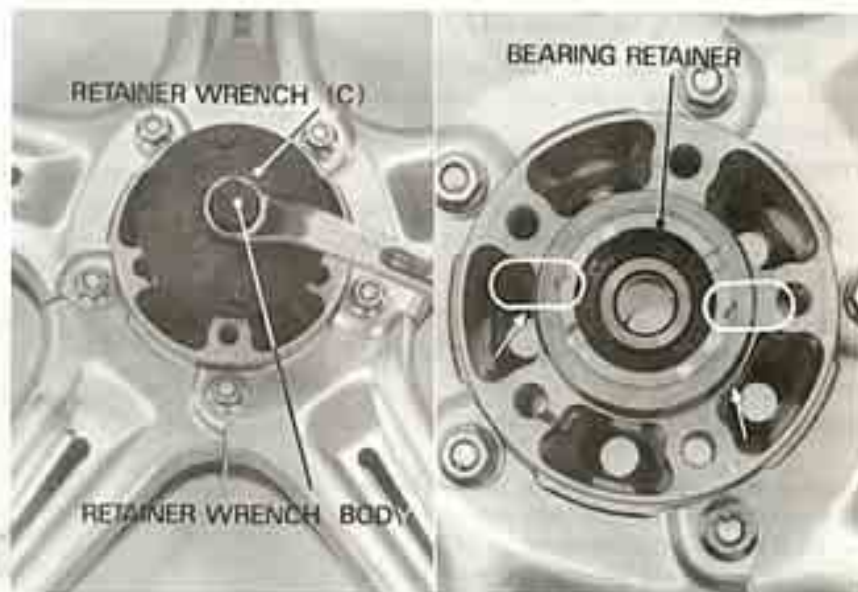

### NOTE

The spoke plate bolts and nuts require no retightening since they are secured with lock pins. Do not remove the pins.

Install the speedometer gear retainer.  
Lubricate the inside of the oil seal and install it.

Install the speedometer gear in the wheel hub, aligning the tangs with the slots.

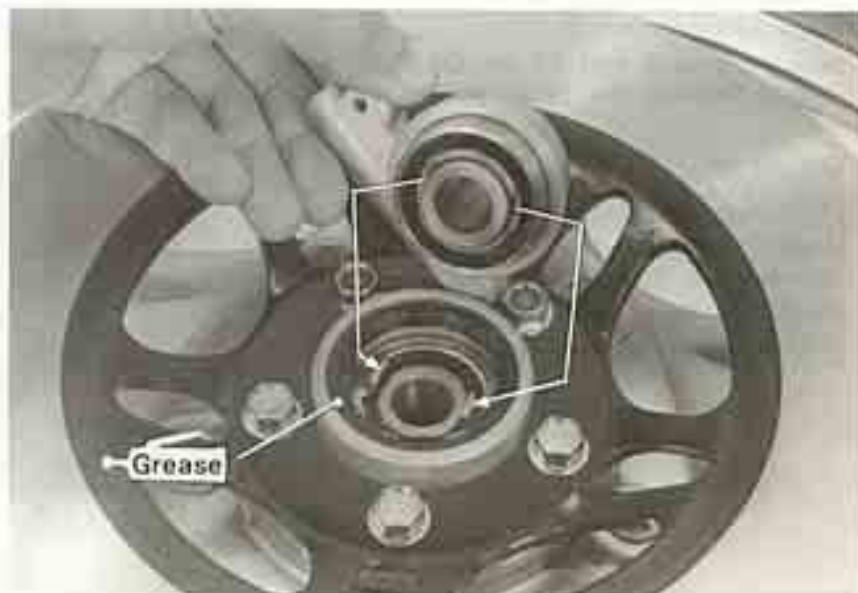



Install the left and right discs.

**TORQUE: 2.7–3.3 kg-m (20–24 ft-lb)**

Install the left side collar and axle.

Install the axle nut.

**TORQUE: 5.5–6.5 kg-m (40–47 ft-lb)**

Clean the brake discs with a high quality degreasing agent.



### FRONT WHEEL INSTALLATION

Fit the calipers over the discs, taking care not to damage the brake pads. Install the caliper mounting bolts.

**TORQUE: 3.0–4.0 kg-m (22–29 ft-lb)**

Install the axle holders with the "F" arrow forward. Tighten the forward axle holder nuts lightly.

Tighten the right axle holder nuts to the specified torque, starting with the forward nuts.

**TORQUE: 1.8–2.5 kg-m (13–18 ft-lb)**

Measure the outside surface of the left brake disc and the rear of the left caliper holder with a 0.7 mm (0.028 in) feeler gauge.

If the gauge cannot be inserted, pull the left fork out until the gauge can be inserted.

Tighten the left holder nuts.

There should be at least 0.7 mm (0.028 in) clearance between the caliper holder and disc.

#### CAUTION

*After installing the wheel, apply the brakes several times and recheck the clearance on both sides. Failure to provide clearance will damage the brake discs and affect braking efficiency.*

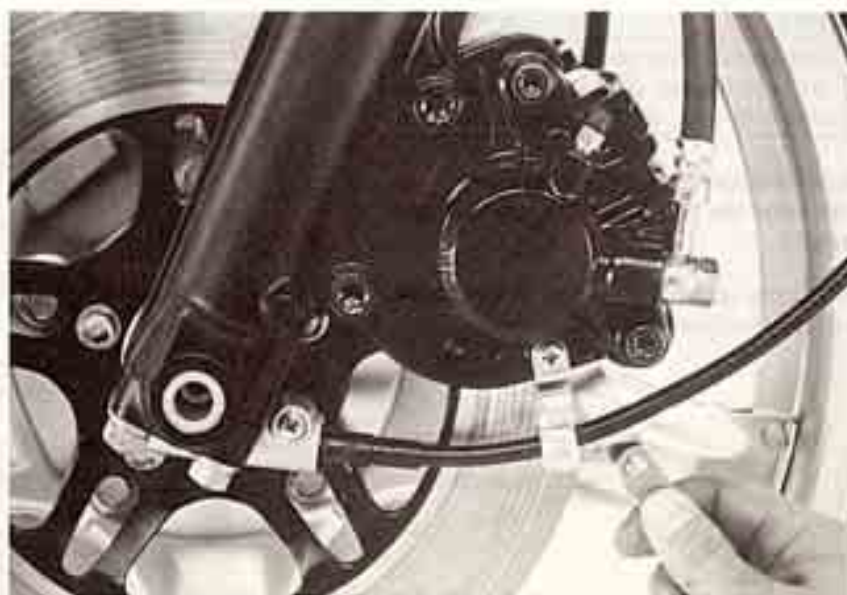
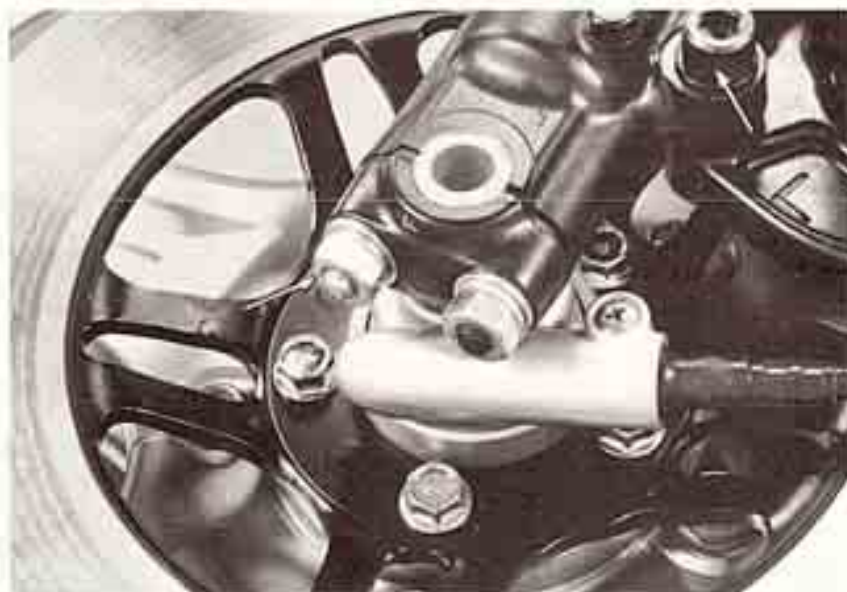





## FRONT FORK

### FRONT FORK OIL CHANGE

Remove the handlebar set bolt and filler plug. Place a pan below the fork, remove the drain plug and allow the fork oil to drain.

Compress the suspension a few times to completely drain the fork.

Refill the fork, page 13-23.

#### REFILL CAPACITY:

157-162 cc (5.3-5.5 ozs)

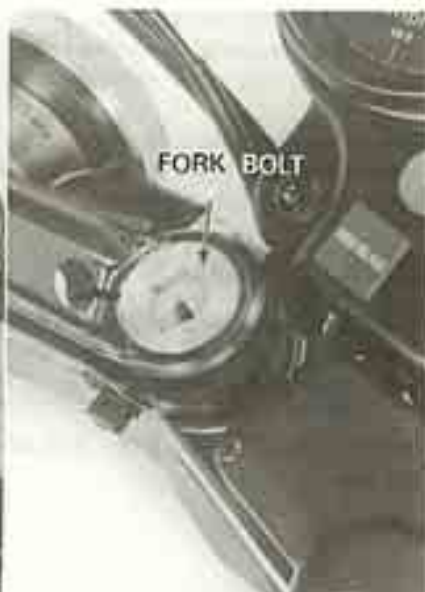

Repeat this operation for the remaining fork leg.



### FORK REMOVAL

Remove the front wheel.  
Remove the brake calipers.

#### NOTE

Do not loosen the brake hose unless necessary.

Remove the front fender.







Remove the handlebar set bolt.  
Loosen the handlebar mounting bolt.  
Loosen the top and bottom fork pinch bolts.  
Remove the fork assembly.  
Remove the fork tubes from the bottom fork bridge, rotating them by hand.

**NOTE**

If the fork has been removed due to accident damage, the stem and crown should be checked for alignment and the bearings for damage.

Remove the oil filler plugs and drain the fork legs.

**FORK DISASSEMBLY**

Remove the socket from the bottom of the fork leg.  
Remove the fork tubes and piston.

**NOTE**

- Hold the fork slider in a vise with soft jaws, being careful not to overtighten it.
- Temporarily install the spring and fork bolt should difficulty be encountered in removing the bolt.

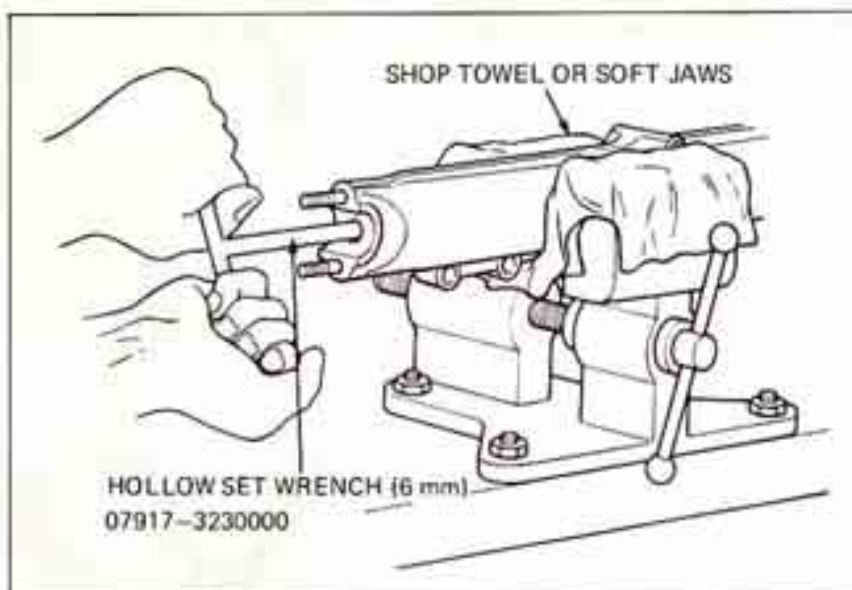
**OIL SEAL REMOVAL**

Carefully remove the oil seal with a screwdriver.

**NOTE**

Avoid damaging the inner and outer surfaces of the slider when removing the seal.

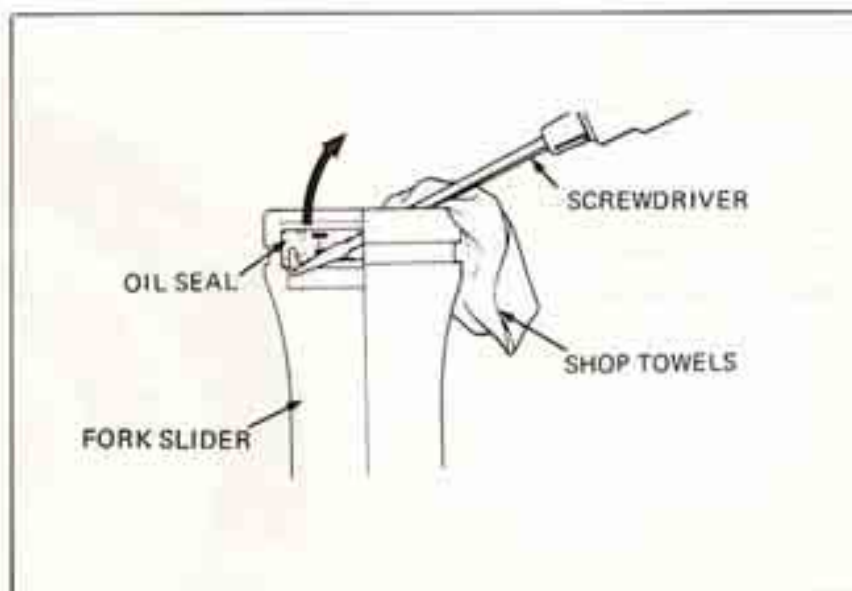



### SPRING FREE LENGTH INSPECTION

Check the free length of the fork spring. Replace it if it does not meet the specification.

**SERVICE LIMIT: 552.0 mm (21.7 in)**

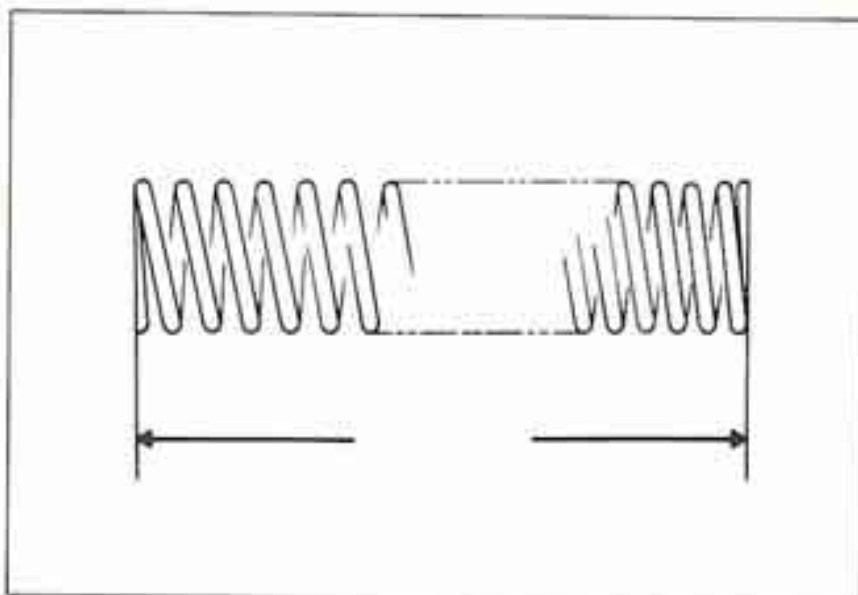

### FORK TUBE/FORK SLIDER/PISTON INSPECTION

Check the fork tubes, fork sliders and pistons for score marks, scratches, or excessive or abnormal wear, replacing those which cannot be reused.

Remove the fork seal. Measure the inside diameter of the guide bushing.

Measure the outside diameter of the fork tube and check the condition of the tube piston and rings.

**Front fork slider I.D.**

**SERVICE LIMIT: 35.25 mm (1.388 in)**

**Front fork tube O.D.**

**SERVICE LIMIT: 34.85 mm (1.372 in)**

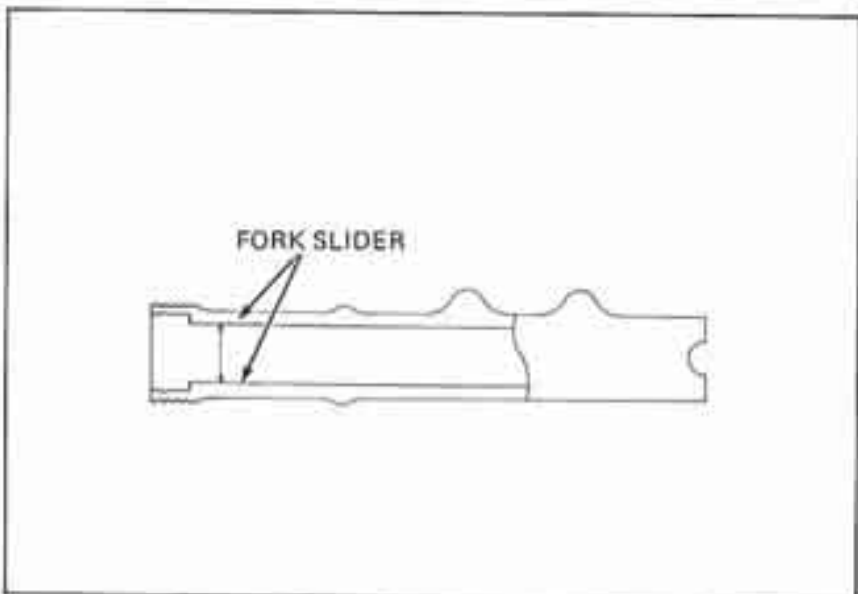

### FORK TUBE INSPECTION

Set the fork tube in V blocks and read the runout. Take 1/2 TIR to determine the actual runout.

**RUNOUT  
SERVICE LIMIT:  
0.2 mm (0.008 in)**

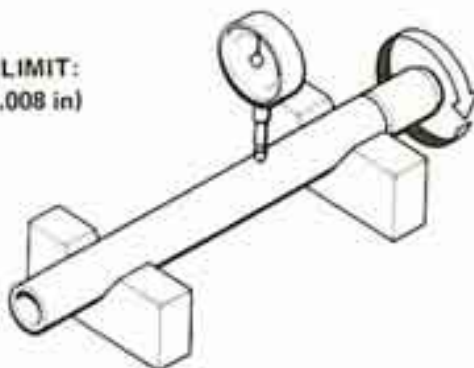



**FORK ASSEMBLY**

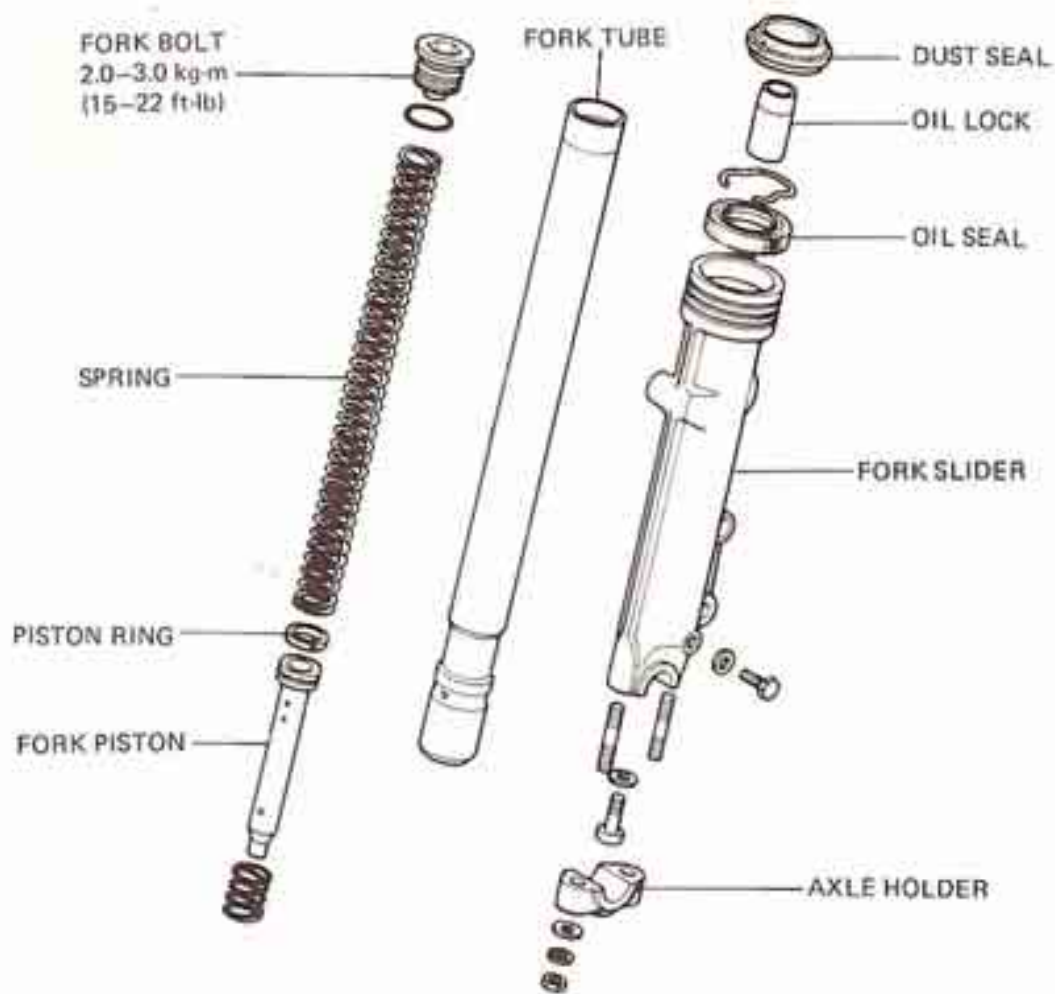

**OIL SEAL INSTALLATION**

Dip the new fork seal in ATF and install it in the slider using the fork leg as a guide for the seal driver.

Drive the oil seal into position until the snap ring groove appears. Install the snap ring and dust cover.

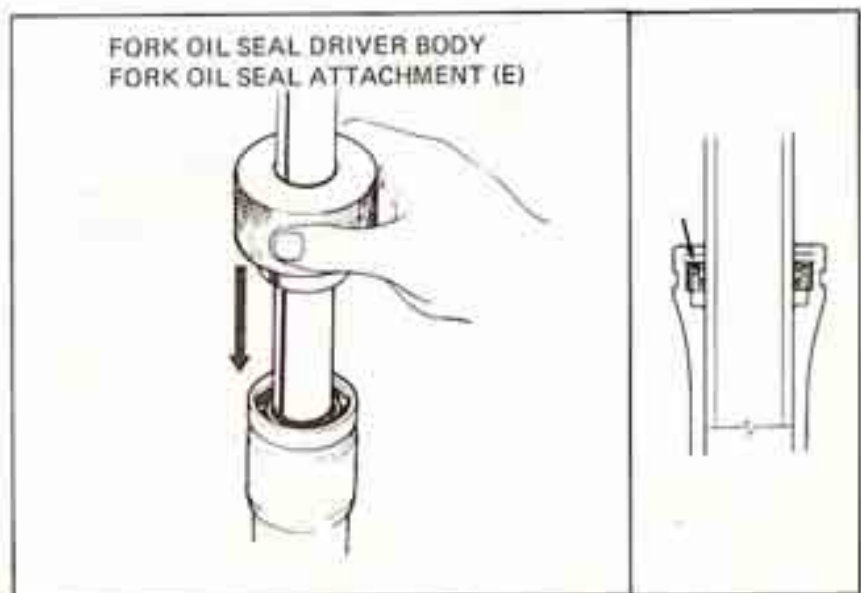





Install the piston and fork tube.  
Apply a locking agent to the bolt threads and underside of the bolt and torque to the specified tension.

**TORQUE.** 0.8–1.2 kg-m (6–9 ft-lb)

### NOTE

Do not overtighten the fork slider in a vise.

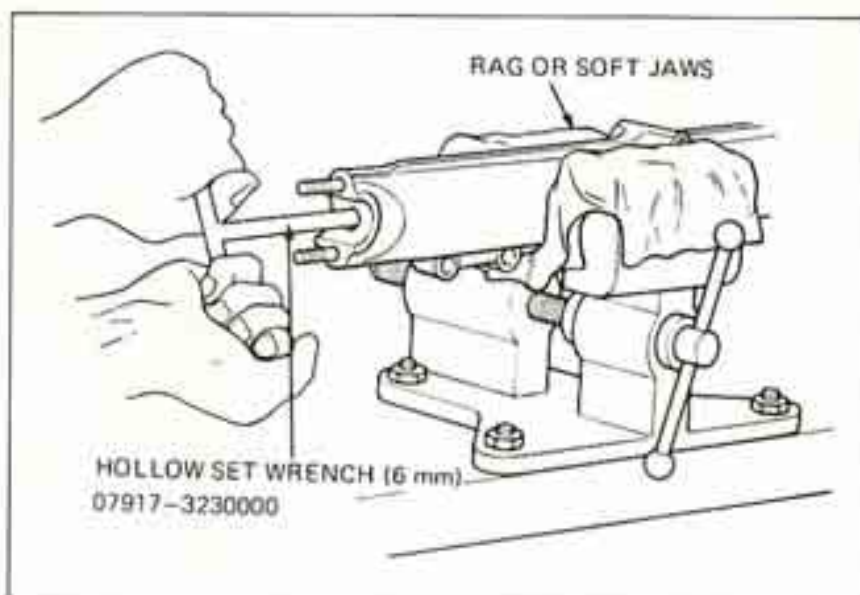

### FILLING WITH OIL

Use ATF (Automatic Transmission Fluid) to fill the front fork.

#### OIL CAPACITY:

177–182 cc (6.0–6.2 ozs) at assembly

### NOTE

Pour the specified amount of ATF. Do not overfill.



Slide the fork spring and spring seat into position.

Clean the fork bolt and tighten.

**TORQUE:** 2.0–3.0 kg-m (15–22 ft-lb)

### NOTE

- Place the fork tube in a vise with soft jaws, avoiding the sliding surface.
- Note the spring direction.

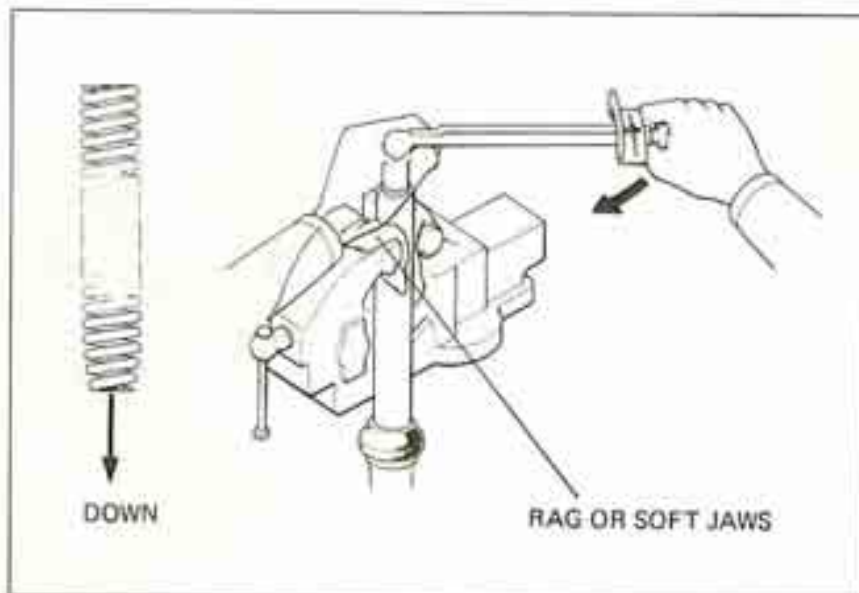



### FORK INSTALLATION

Install the fork tubes in the fork top bridge and steering stem, while rotating them by hand.

Position the fork tubes so that the aligning lines are even with the fork top bridge.

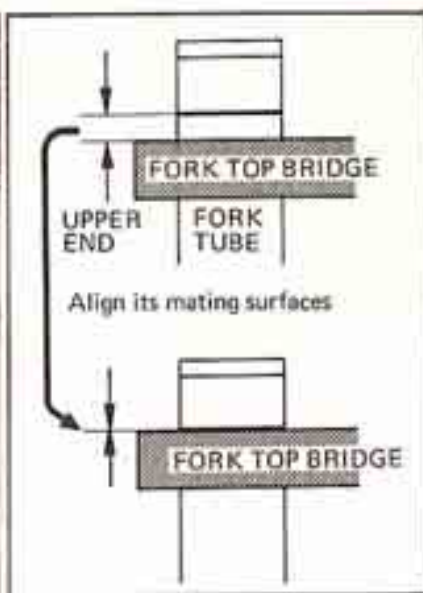

Tighten the right and left handlebar mounting bolts.

**TORQUE:** 2.8–3.2 kg-m (20–23 ft-lb)

#### NOTE

Before installing the handlebar mounting bolts, coat the bolts threads with oil.

Torque the fork tube pinch bolts at the steering stem.

**TORQUE:** 1.8–2.5 kg-m (13–18 ft-lb)

Torque the fork tube pinch bolts at the top bridge.

**TORQUE:** 0.9–1.3 kg-m (7–9 ft-lb)



Install the fender.  
 Install the brake caliper.  
 Secure the brake hose.  
 Install the front wheel.

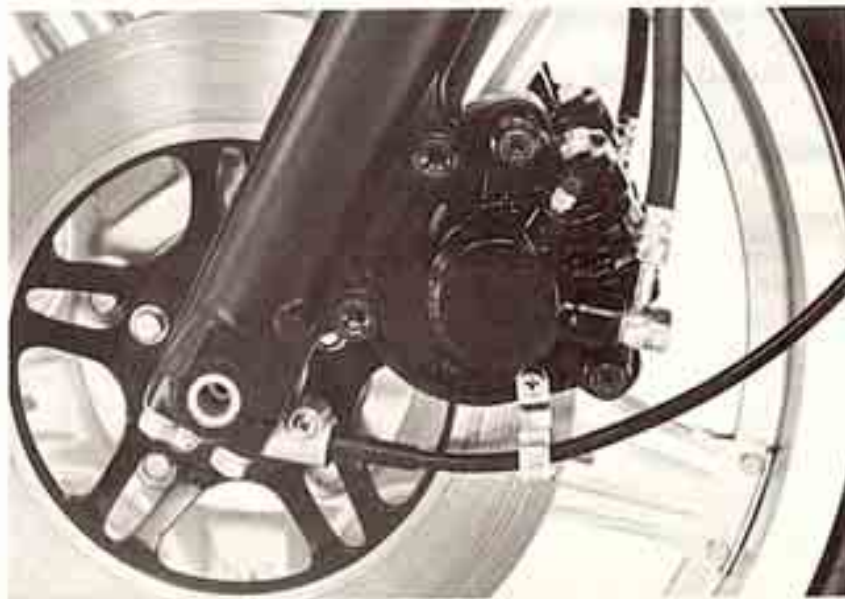



## STEERING STEM

### STEM REMOVAL

Remove the handlebars.  
Remove the instruments (Page 13-6).  
Remove the headlight assembly and disconnect the wiring (Page 13-5).  
Remove the 2-way joint assembly.  
Remove the wheel and forks.  
Remove the fuse cover.  
Remove the fork top bridge.

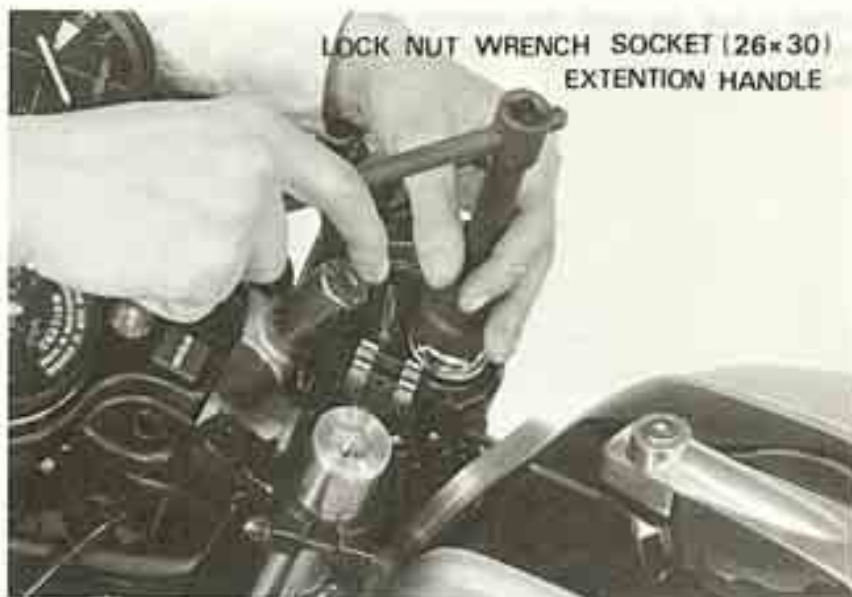

Remove the top thread nut.  
Remove the steering stem.



Remove the lower steering stem bearing.







Install a dust seal onto the steering stem and drive the lower bearing inner race over the stem with the special tool.

STEERING STEM DRIVER  
07946 - 3710600



**NOTE**

Replace the bearing and bearing race as a set.

Remove the upper bearing race with the special tool.

STEERING STEM DRIVER  
07946-3710600



Remove the lower bearing race with the special tool.

**NOTE**

If the motorcycle has been involved in an accident, examine the area around the steering head for cracks.

STEERING STEM DRIVER  
07946-3710600

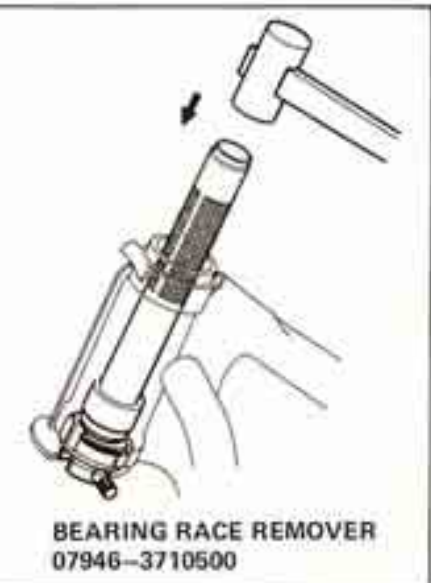

BEARING RACE REMOVER  
07946-3710500



Drive the upper bearing outer race into the head pipe with the special tools.

Drive the lower bearing outer race into the head pipe with the special tool.



### STEERING STEM INSTALLATION

Pack the bearing cavities with bearing grease. Insert the steering stem into the steering head pipe and install the upper bearing inner race.

Install the steering head top nut and tighten to 3.0-4.0 kg-m (22-28 ft-lb).

Loosen the top nut and retighten to 0.8-1.2 kg-m (6-9 ft-lb).



### TOP BRIDGE INSTALLATION

Install the front fork legs.

Position the fork tubes so that the upper ends are even with the steering head adjuster.

Temporarily hold the front fork legs by tightening the steering stem fork pinch bolts.





Torque the steering stem nut.

**TORQUE:** 8.0–12.0 kg-m (58–87 ft-lb)

LOCK NUT WRENCH SOCKET (26×30)  
EXTENSION HANDLE



Torque the bottom bridge fork bolts.

**TORQUE:** 1.8–2.5 kg-m (13–18 ft-lb)

Install the following:

- Handlebars
- Instruments
- Headlight
- Front fender
- Front wheel





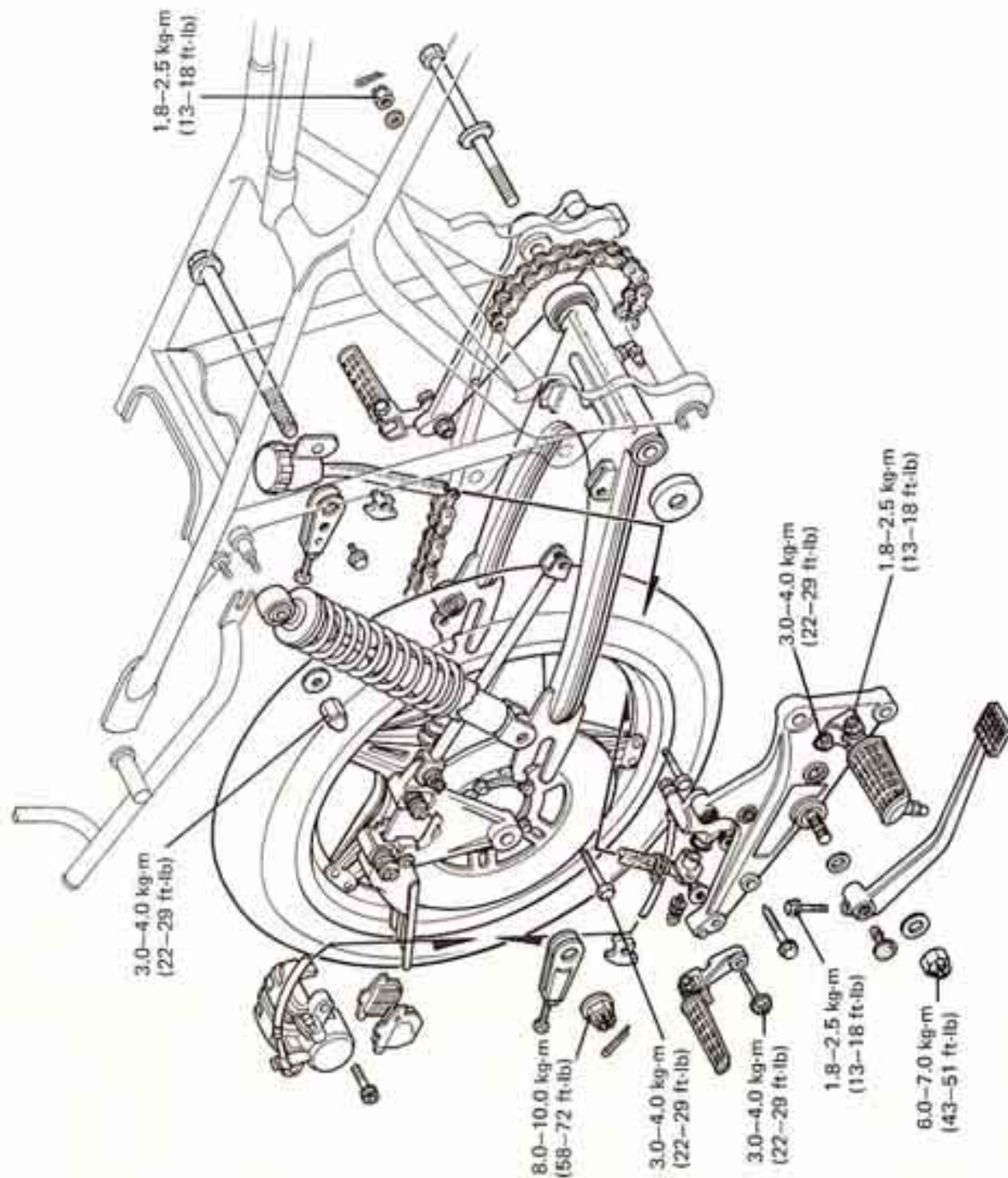



SERVICE INFORMATION	14-1
TROUBLESHOOTING	14-2
REAR WHEEL	14-3
SHOCK ABSORBER	14-8
SWING ARM	14-11

## SERVICE INFORMATION

### WORKING PRACTICE

The rear wheel uses a tubeless tire. For tubeless tire repairs, refer to the TUBELESS TIRE MANUAL, code No. 6141550.

Do not remove rivets, nuts and pins from the rim, spoke plate and hub.

Never ride on the rim or try to bend wheel.

Avoid damaging the aluminum alloy rim.

### SPECIAL TOOLS

#### Common Tools

Bearing Driver Handle (A)	07749-0010000
Bearing Driver Outer (62 x 68 mm)	07746-0010500
Bearing Driver Outer (52 x 55 mm)	07746-0010400
Bearing Driver Pilot (20 mm)	07746-0040500
Bearing Driver Pilot (25 mm)	07746-0040600
Rear Cushion Compressor	07959-3290001
Retainer Wrench Body	07710-0010400
Retainer Wrench A.	07710-0010100

### TORQUE VALES

Rear brake disc	2.7-3.3 kg-m (20-24 ft-lb)
Driven sprocket	8.0-10.0 kg-m (58-72 ft-lb)
Rear axle	8.0-10.0 kg-m (58-72 ft-lb)
Rear shock absorber	3.0-4.0 kg-m (22-29 ft-lb)
Swing arm pivot bolt	6.0-7.0 kg-m (43-51 ft-lb)
Rear brake rod nut	1.8-2.5 kg-m (13-18 ft-lb)

### SPECIFICATIONS

		STANDARD	SERVICE LIMIT
Axle runout		—	0.2 mm (0.008 in)
Rear wheel rim runout	Radial	—	2.0 mm (0.08 in)
	Axial	—	2.0 mm (0.08 in)
Shock absorber spring free length		254.2 mm (10.0 in)	249.5 mm (9.82 in)
Swing arm bushing	I.D.	21.500-21.552 mm (0.8465-0.8485 in)	21.7 mm (0.854 in)
Swing arm collar	O.D.	21.427-21.460 mm (0.8436-0.8449 in)	21.4 mm (0.843 in)



## TROUBLESHOOTING

### Wobble or Vibration in Motorcycle

1. Distorted rim
2. Loose wheel bearing
3. Loose or distorted spokes
4. Faulty tire
5. Loose axle
6. Tire pressure incorrect
7. Swing arm bushing worn

### Soft Suspension

1. Weak spring
2. Shock absorber improperly adjusted

### Hard Suspension

1. Shock absorbers improperly adjusted
2. Bent shock absorber

### Suspension Noise

1. Shock case binding
2. Loose fasteners





## REAR WHEEL

### REAR WHEEL REMOVAL

Place the motorcycle on its center stand. Loosen the drive chain adjuster lock nuts and bolts.

Remove the cotter pin from the rear axle and loosen the nut.

Pull the adjusters down, push the wheel forward and remove the drive chain from the drive sprocket.

Remove the rear wheel.

Remove the rear axle.

#### NOTE

Do not operate the rear brake pedal after removing the rear wheel. To do so will cause difficulty in refitting the brake disc between the brake pads.



### REAR WHEEL DISASSEMBLY

Remove the rear disc.

Loosen the driven sprocket nuts.



Remove the driven flange from the wheel hub.

Remove the driven sprocket.





**REAR WHEEL/SUSPENSION**

Remove the bearing retainer.



**AXLE INSPECTION**

Set the axle in V blocks and read the axle runout.  
The actual axle runout is 1/2 of TIR (Total Indicator Reading).

**SERVICE LIMIT: 0.2 mm (0.008 in)**

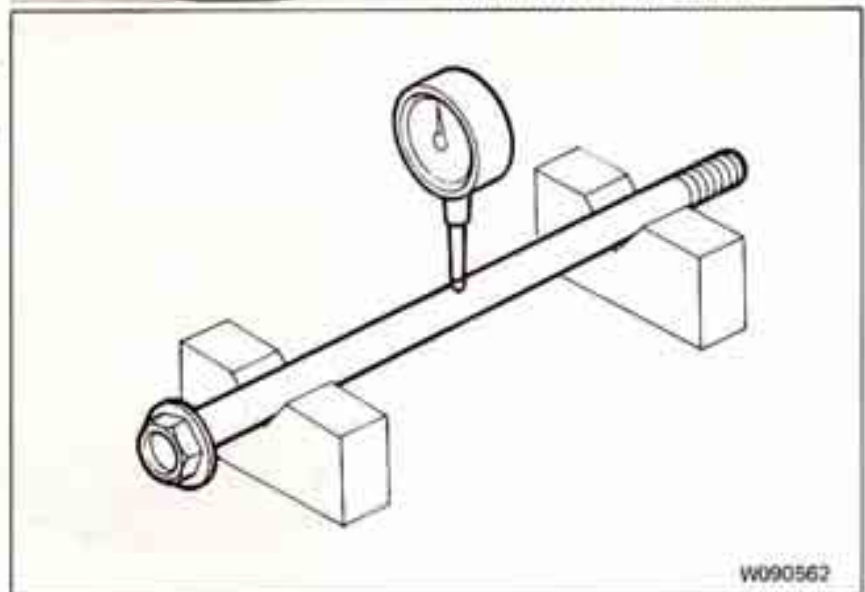

**REAR WHEEL BEARING PLAY INSPECTION**

Check the wheel bearing play by rotating the wheel by hand. Replace the bearing with new ones if they are noisy or have excessive play.

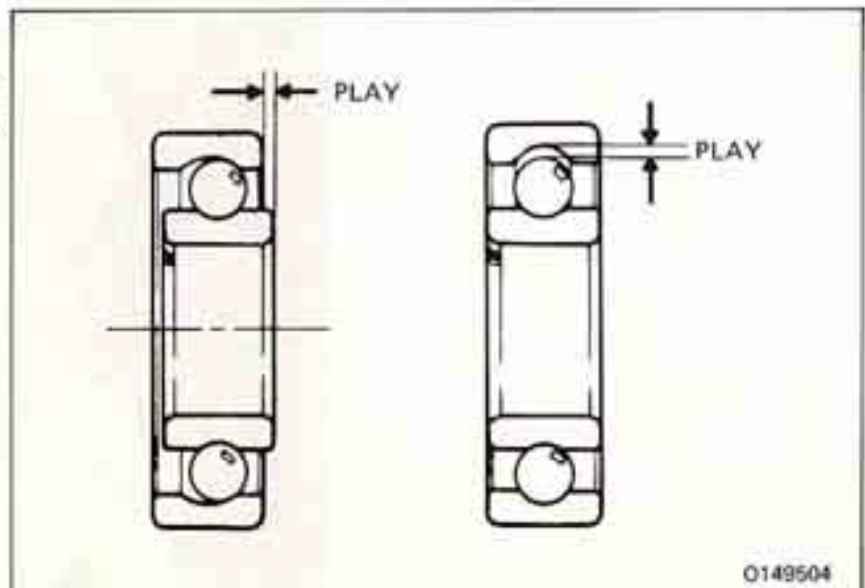



### REAR WHEEL RIM RUNOUT INSPECTION

Check the rim for runout by placing the wheel in a truing stand. Spin the wheel slowly, and read the runout using a dial indicator.

#### SERVICE LIMITS:

RADIAL RUNOUT: 2.0 mm (0.08 in)

AXIAL RUNOUT: 2.0 mm (0.08 in)

#### NOTE

The COMSTAR WHEEL cannot be serviced and must be replaced if the above limits are exceeded.

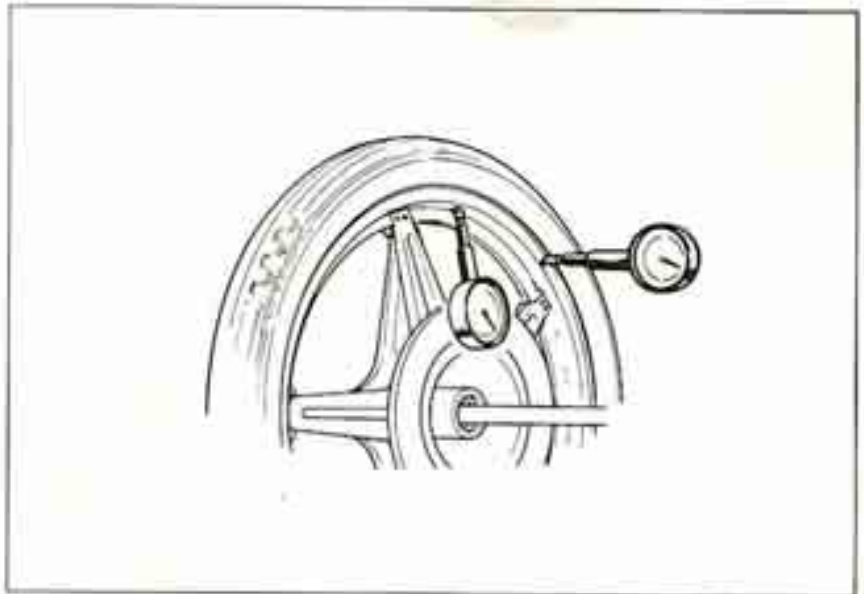

### FINAL DRIVEN SPROCKET INSPECTION

Check the condition of the final driven sprocket teeth.

Replace the sprocket if worn or distorted.

#### NOTE

If the final driven sprocket requires replacement, inspect the drive chain and drive sprocket. (See 3-16)

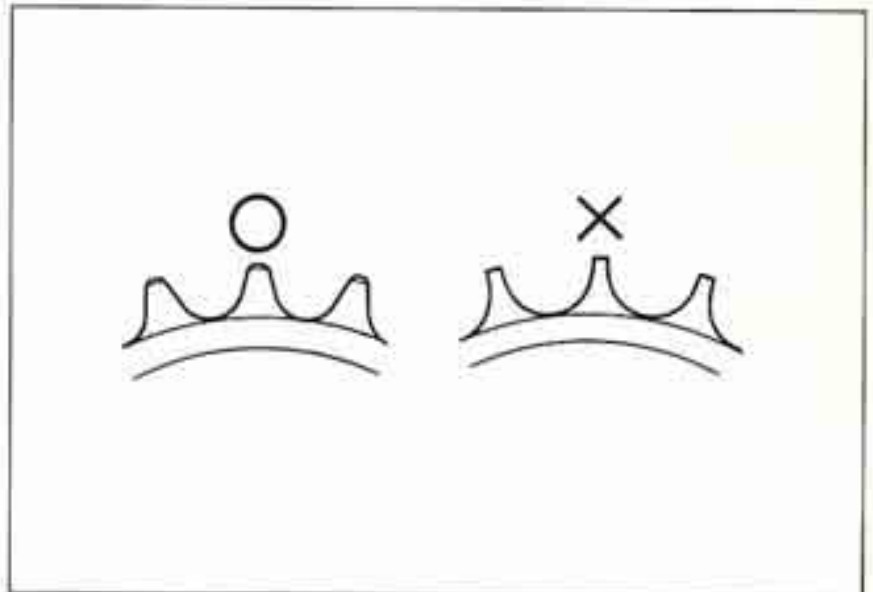

### DAMPER RUBBER INSPECTION

Replace the damper rubbers if they are damaged or deteriorated.







**REAR WHEEL/SUSPENSION**

**REAR WHEEL ASSEMBLY**

**NOTE**

The rear wheel uses a tubeless tire. For tubeless tire repairs, refer to **TUBELESS TIRE MANUAL**.

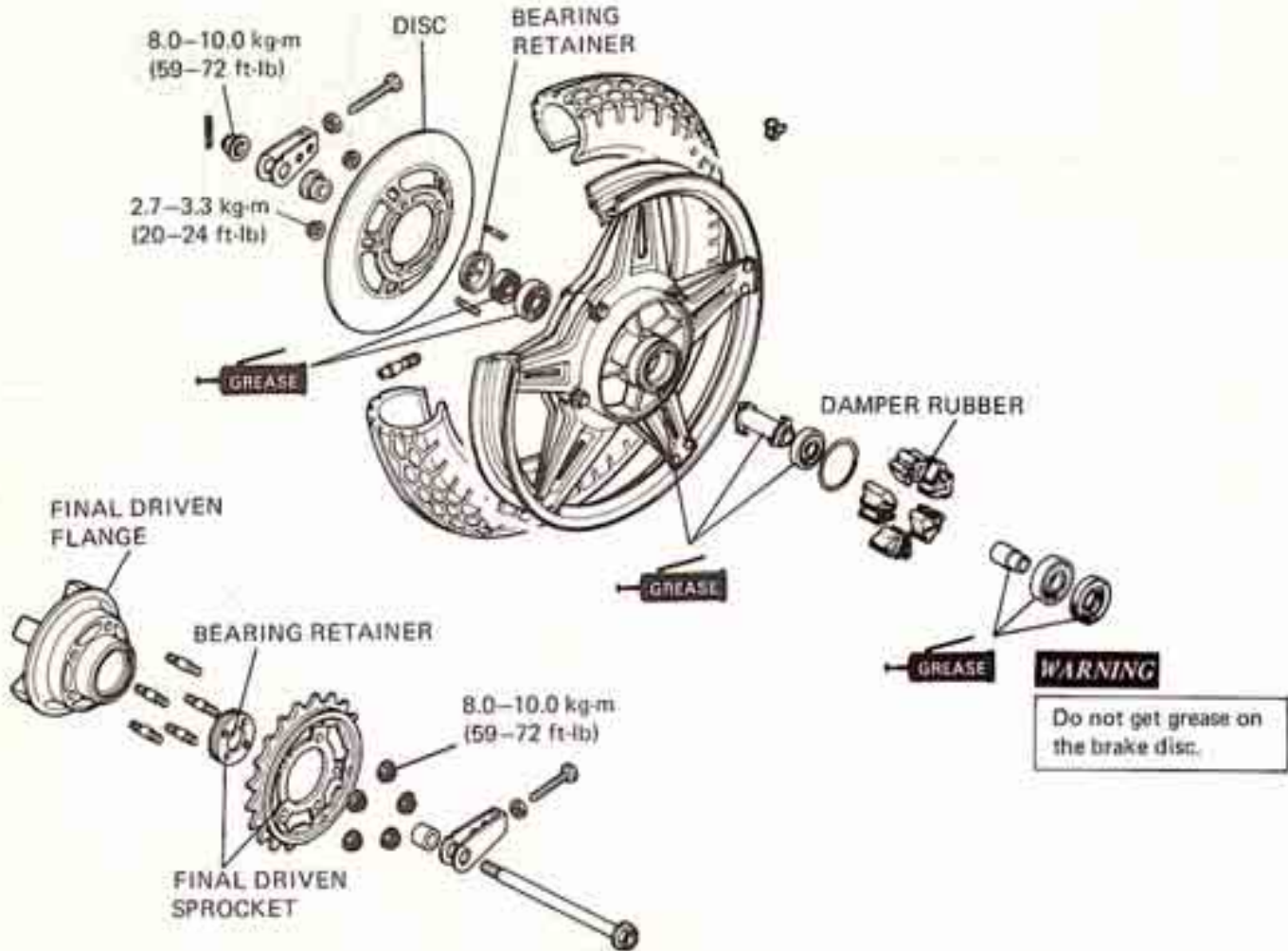

Pack all bearing cavities with grease.  
Press the distance collar into place from the left side.  
Drive the right ball bearing first, then the left ball bearing.

**CAUTION**

Drive the bearings squarely.  
Install the bearings with the sealed end facing out, making sure they are fully seated.

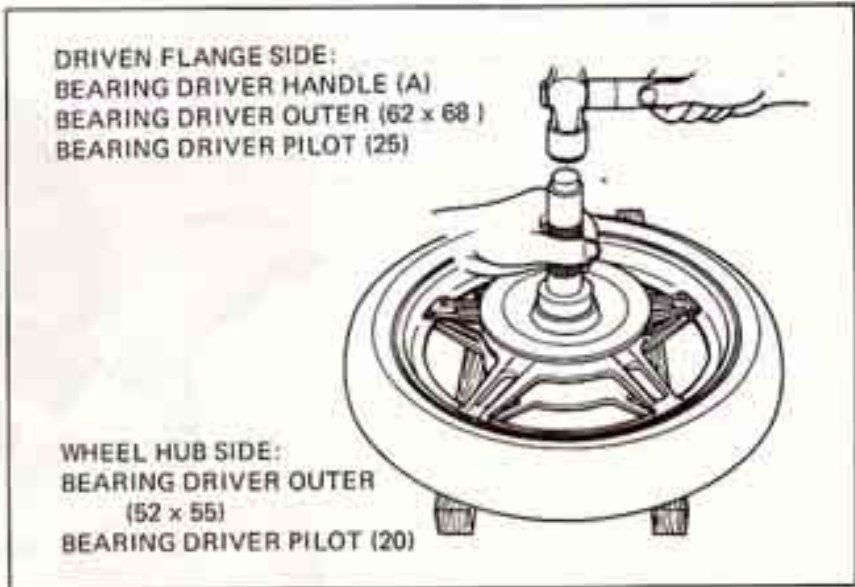



Install the bearing retainer with the same tool that was used to remove it. Peen it to the hub.

**NOTE**

Check the condition of the bearing retainer.  
If the threads are damaged, the retainer should be replaced.

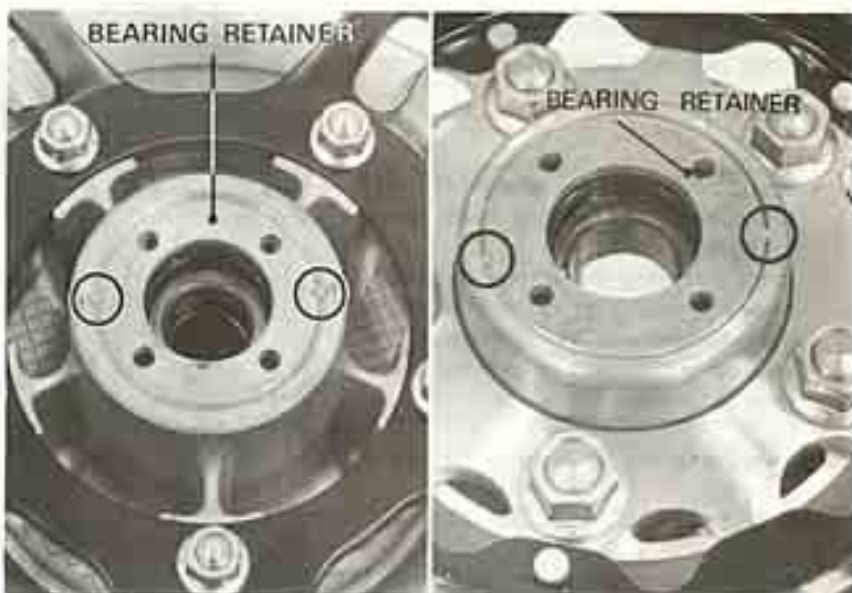

Install the rear brake disc and nut.

**TORQUE: 2.7–3.3 kg-m (20–24 ft-lb)**

Clean the brake disc with a high quality degreasing agent.



Install the final driven sprocket.

**TORQUE: 8.0–10.0 kg-m (58–72 ft-lb)**







## REAR WHEEL INSTALLATION

Install the rear wheel in the reverse order of removal.

### NOTE

- When installing the wheel, fit the brake disc between the brake pads carefully.
- After installing the wheel, apply the brakes several times and then check if the wheel rotates freely. Recheck the wheel if the brake drags or if the wheel does not rotate freely.

Use a new cotter pin for securing the axle nut.

**TORQUE: 8.0–10.0 kg-m (58–72 ft-lb)**

Adjust the drive chain free play. (See 3-16)

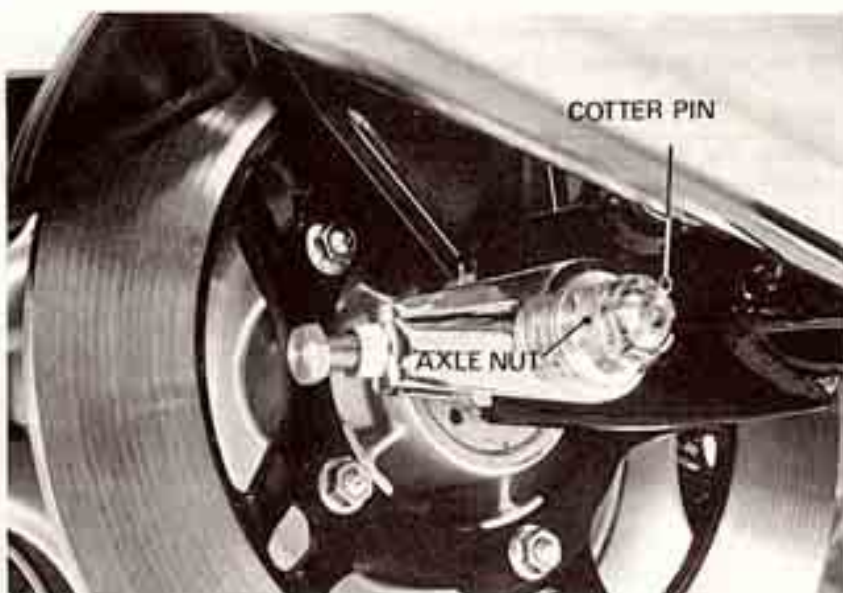

## SHOCK ABSORBER

### SHOCK ABSORBER REMOVAL

Remove the upper and lower shock absorber mounting bolts and nuts and remove the shock absorbers.







### SHOCK ABSORBER DISASSEMBLY

Compress the spring just enough to remove the lock nut.

Loosen the lock nut and remove the top eye.

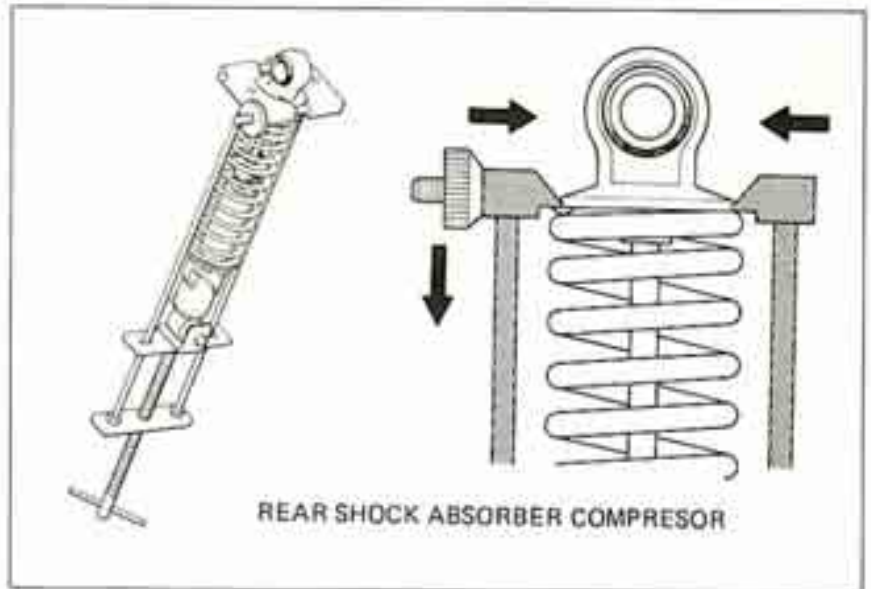
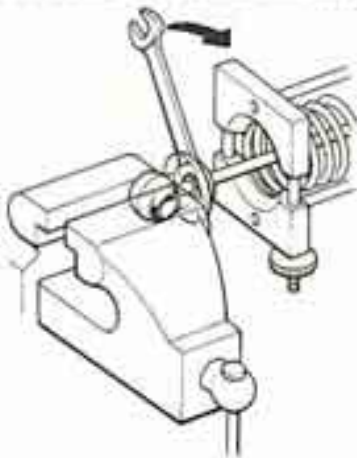

### SHOCK ABSORBER SPRING FREE LENGTH

Disassemble the unit.

Measure the free length of the spring. Inspect the shock body for oil leaks.

**SERVICE LIMIT: 249.5 mm (9.82 in)**

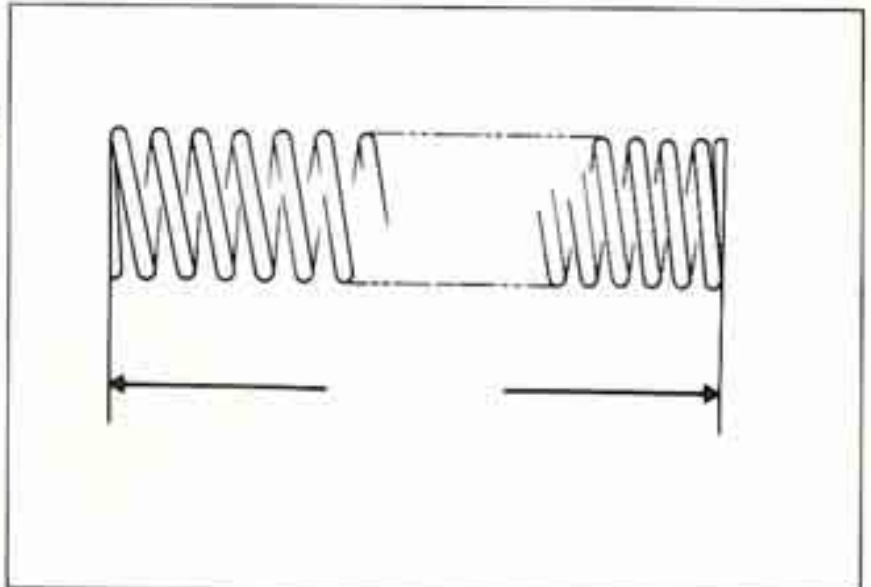

### SHOCK ABSORBER ASSEMBLY

#### NOTE

Install the spring with the small coil at the bottom.

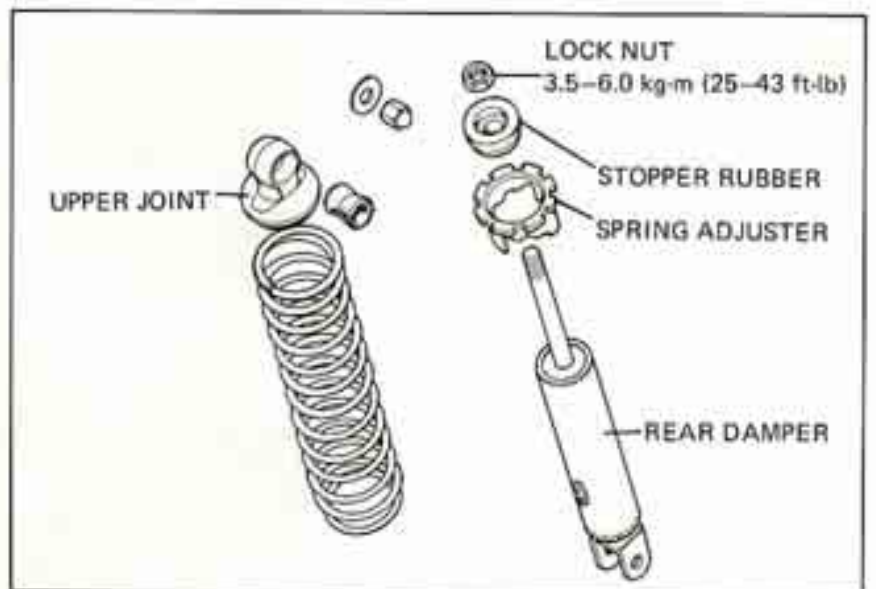



**NOTE**

Apply locking agent to the lock nut at time of assembly.

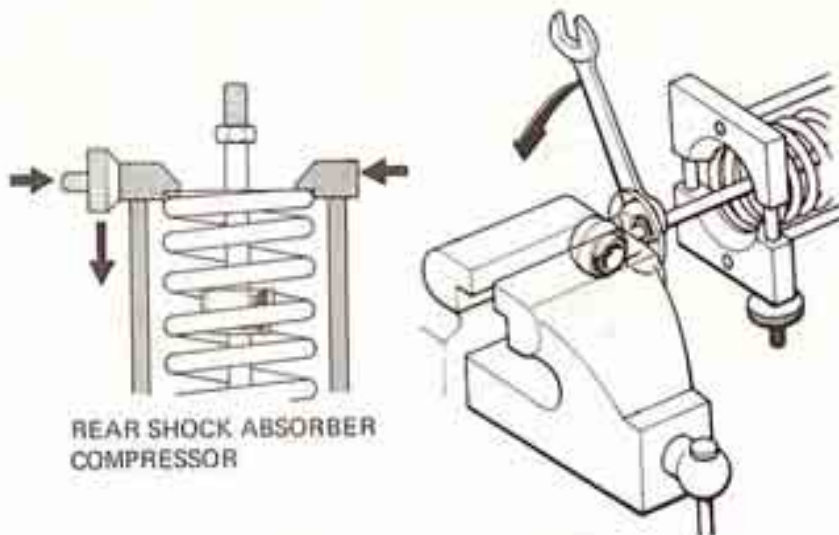

**SHOCK ABSORBER INSTALLATION**

Torque the shock absorber bolts and nuts.

**TORQUE: 3.0-4.0 kg-m (22-29 ft-lb)**



Adjust the right and left absorbers equally with the spring adjuster.

Check shock absorber operation after installation.

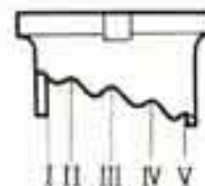

STANDARD: I



### SWING ARM

#### SWING ARM REMOVAL

- Remove the rear wheel. (Page 14-3)
- Disconnect the rear brake torque rod from the brake caliper.
- Remove the drive chain guard.
- Remove the right and left shock absorbers.
- Remove the swing arm.

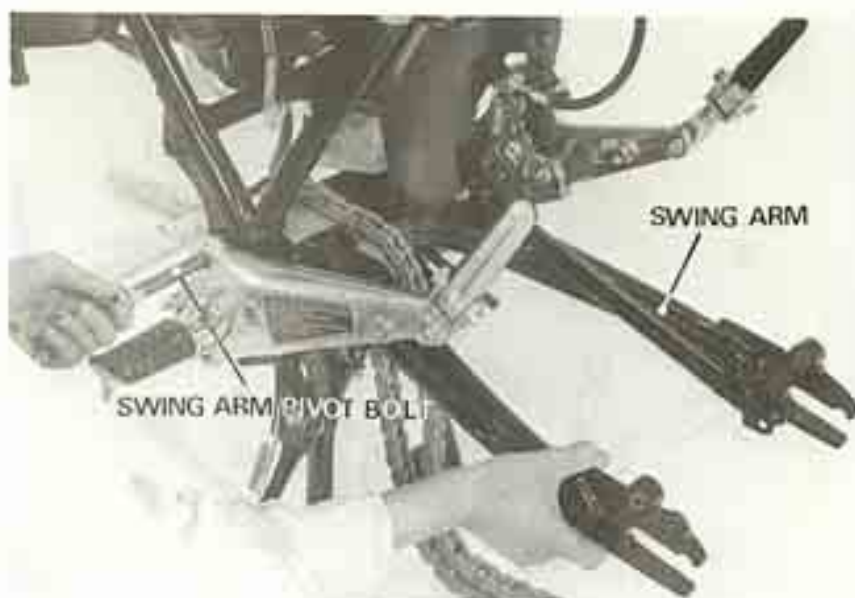

#### SWING ARM DISASSEMBLY/ ASSEMBLY

##### NOTE

Drive the bushings into place, with a soft hammer, making sure that they are not damaged.  
Lubricate with grease after installation.

- SWING ARM BUSHING I.D. SERVICE LIMIT:  
21.7 mm (0.854 in)
- SWING ARM COLLAR O.D. SERVICE LIMIT:  
21.4 mm (0.843 in)

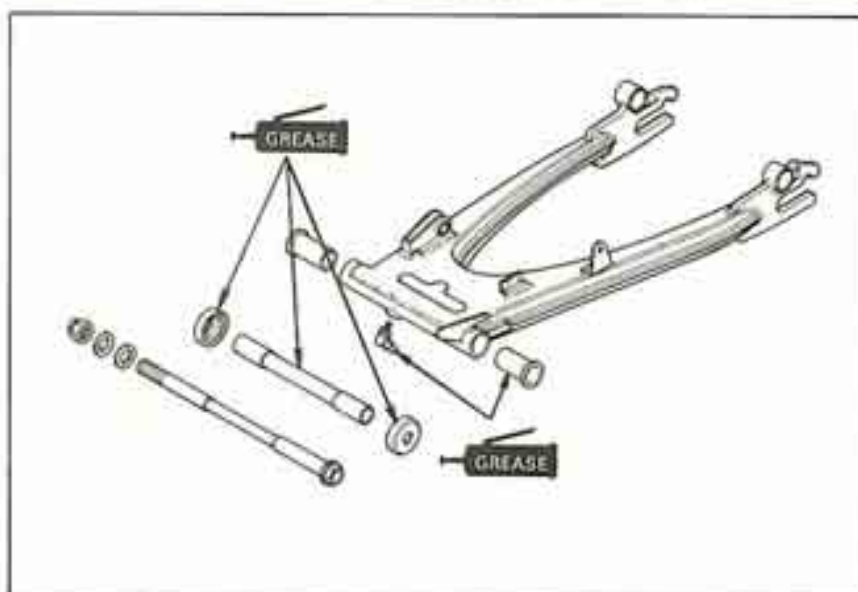

#### SWING ARM INSTALLATION

- Place the drive chain over the swing arm.
- Tighten the swing arm pivot bolt.

**TORQUE: 6.0–7.0 kg-m (43–51 ft-lb)**

- Install the shock absorbers.

**TORQUE: 3.0–4.0 kg-m (22–29 ft-lb)**

- Install the rear wheel.







HYDRAULIC BRAKE

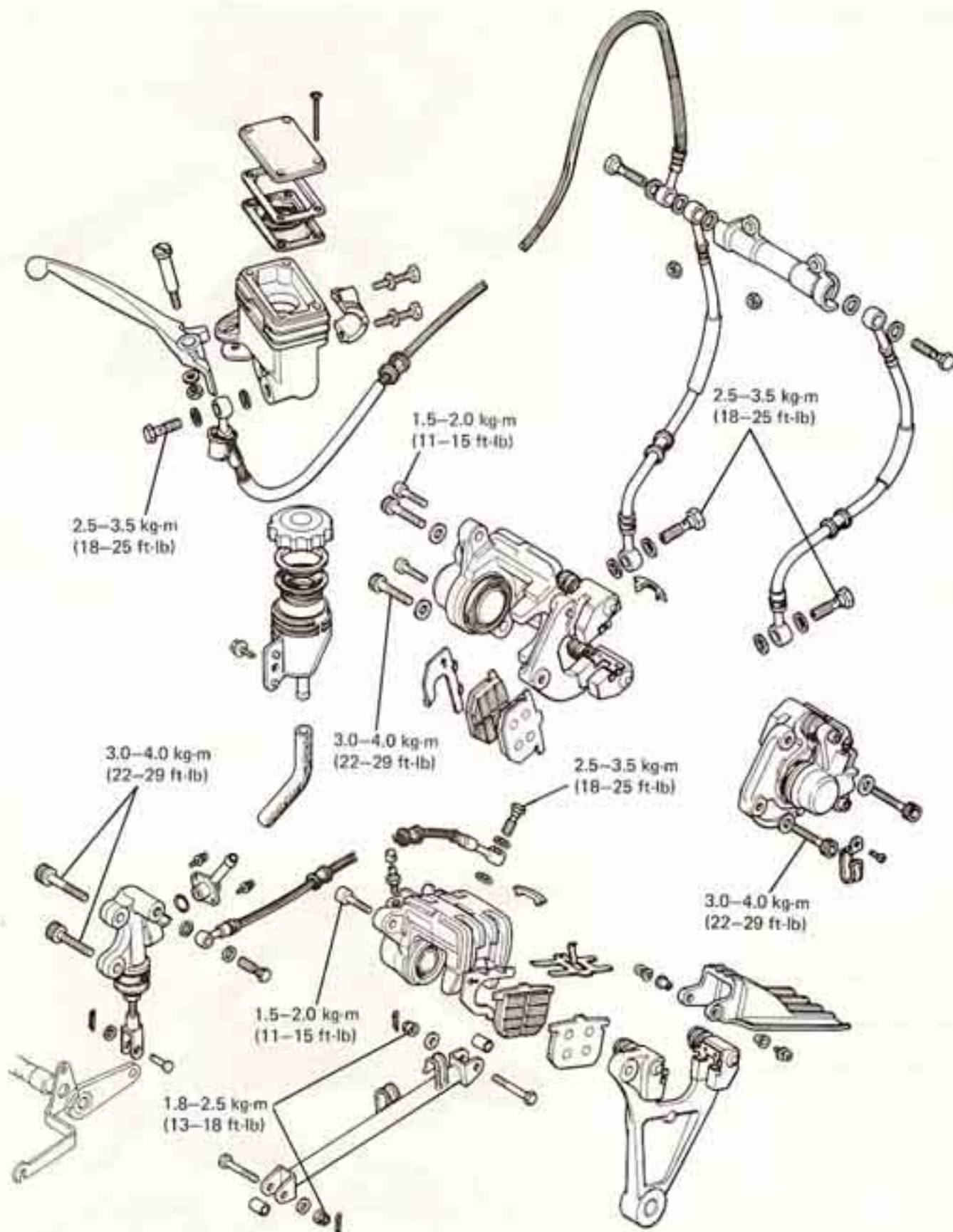



SERVICE INFORMATION	15-1
TROUBLESHOOTING	15-2
BRAKE FLUID REPLACEMENT/AIR BLEEDING	15-3
BRAKE PAD/DISC	15-5
FRONT BRAKE MASTER CYLINDER	15-8
FRONT BRAKE CALIPER	15-11
REAR BRAKE MASTER CYLINDER	15-14
REAR BRAKE CALIPER	15-17
BRAKE PEDAL SHAFT	15-20

## SERVICE INFORMATION

### WORKING PRACTICE

The front and rear brakes can be removed without disconnecting the hydraulic system. Once the hydraulic systems have been opened, or if the brakes feel spongy, the system must be bled. Do not allow foreign material to enter the system when filling the reservoirs. Avoid spilling brake fluid on painted surfaces or instrument lenses, as severe damage will result. Always check brake operation before riding the motorcycle.

### SPECIAL TOOL

Snap Ring Pliers 07914-3230001

### TORQUE VALUES

Brake hose bolt	2.5-3.5 kg-m (18-25 ft-lb)
Front brake caliper-bracket	3.0-4.0 kg-m (22-29 ft-lb)
Front brake caliper	1.5-2.0 kg-m (11-15 ft-lb)
Rear brake caliper	1.5-2.0 kg-m (11-15 ft-lb)
Rear master cylinder	3.0-4.0 kg-m (22-29 ft-lb)
Rear brake rod nut	1.8-2.5 kg-m (13-18 ft-lb)
Rear axle nut	8.0-10.0 kg-m (58-72 ft-lb)

### SPECIFICATIONS

	STANDARD	SERVICE LIMIT
Disc thickness	4.9-5.1 mm (0.19-0.20 in)	4.0 mm (0.16 in)
Disc runout	—	0.3 mm (0.012 in)
Front master cylinder I.D.	15.870-15.913 mm (0.6248-0.6265 in)	15.925 mm (0.6270 in)
Front master piston O.D.	15.827-15.854 mm (0.6231-0.6242 in)	15.815 mm (0.6226 in)
Front caliper piston O.D.	42.772-42.822 mm (1.6839-1.6859 in)	42.765 mm (1.6837 in)
Front caliper cylinder I.D.	42.85-42.90 mm (1.6870-1.6890 in)	42.915 mm (1.6896 in)
Rear master cylinder I.D.	14.000-14.043 mm (0.5512-0.5529 in)	14.06 mm (0.554 in)
Rear master piston O.D.	13.957-13.984 mm (0.5495-0.5506 in)	13.945 mm (0.549 in)
Rear caliper cylinder I.D.	38.180-38.230 mm (1.5031-1.5051 in)	38.24 mm (1.506 in)
Rear caliper piston O.D.	38.098-38.148 mm (1.4999-1.5019 in)	38.09 mm (1.500 in)
Rear disc thickness	6.9-7.1 mm (0.27-0.28 in)	6.0 mm (0.24 in)
Rear disc runout	—	0.3 mm (0.012 in)



## **TROUBLESHOOTING**

### **Brake Lever/Pedal Soft or Spongy**

1. Air bubbles in hydraulic system
2. Low fluid level
3. Hydraulic system leaking

### **Brake Lever/Pedal Too Hard**

1. Sticking piston(s)
2. Clogged hydraulic system
3. Pads glazed or worn excessively

### **Brakes Drag**

1. Hydraulic system sticking
2. Incorrect adjustment of lever or pedal
3. Sticking piston(s)

### **Brakes Grab or Pull to One Side**

1. Pads contaminated
2. Fault in one side of front brake
3. Disc or wheel misaligned

### **Brakes Chatter or Squeal**

1. Pads contaminated
2. Excessive disc runout
3. Caliper installed incorrectly
4. Disc or wheel misaligned





## BRAKE FLUID REPLACEMENT/ AIR BLEEDING

Check the fluid level with the fluid reservoir parallel to the ground.

### CAUTION

- Install the diaphragm on the reservoir when operating the brake lever pedal. Failure to do so will allow brake fluid to squirt out of the reservoir during brake operation.
- Avoid spilling fluid on painted surfaces. Place a rag over the fuel tank whenever the system is serviced.



## BRAKE FLUID DRAINING

Connect a bleed hose to the bleeder valve. Loosen the caliper bleeder valve and pump the brake lever (or pedal). Stop operating the lever (or pedal) when no fluid flows out of the bleeder valve.

### WARNING

*A contaminated brake disc or pad reduces stopping power. Discard contaminated pads and clean a contaminated disc with a high quality brake degreasing agent.*



## BRAKE FLUID FILLING

### NOTE

Do not mix different brands of fluid since they may not be compatible.

Close the bleeder valve, fill the reservoir, and install the diaphragm.

To prevent piston overtravel and brake fluid seepage, keep a 20 mm (3/4 in) space to the handlebar grip when bleeding the front brake system. Pump up the system pressure with the lever until there are no air bubbles in the fluid flowing out of the reservoir small hole and lever (or pedal) resistance is felt.



## AIR BLEEDING

### NOTE

Use this procedure for the front and rear brakes.

### NOTE

Check the fluid level often while bleeding the brake to prevent air from being pumped into the system.

### NOTE

- Use only DOT 3 brake fluid from a sealed container.
- Do not mix brake fluid brands and never re-use the contaminated fluid which has been pumped out during brake bleeding, because this will impair the efficiency of the brake system.



- i) Squeeze the brake lever (or depress the brake pedal), open the bleeder valve 1/2 turn then close the valve.

### NOTE

Do not release the brake lever (or pedal) until the bleeder valve has been closed again.

- ii) Release the brake lever (or pedal) slowly and wait several seconds after it reaches the end of its travel.

Repeat the above steps (i) and (ii) until bubbles cease to appear in the fluid at the end of the hose.

Fill the fluid reservoir to the upper level mark.



### WARNING

*A contaminated brake disc or pad reduces stopping power. Discard contaminated pads and clean a contaminated disc with a high quality brake degreasing agent.*







### BRAKE PAD/DISC

#### FRONT BRAKE PAD WEAR CHECK

Replace the front brake pads if the red line on the top of the pads reaches the edge of the brake disc.

#### NOTE

Always replace the brake pads in pairs to assure even disc pressure.

#### FRONT BRAKE PAD REPLACEMENT

Remove the two caliper allen head bolts.

Lift off the caliper and remove both brake pads and the shim.

Install the new brake pads and the shim.

#### NOTE

- Install the shims with the  facing up.
- Push the piston all the way in.
- Check the brake fluid level in the brake master cylinder reservoir as this causes the level to rise.
- Always replace the brake pads in pairs to assure even disc pressure.

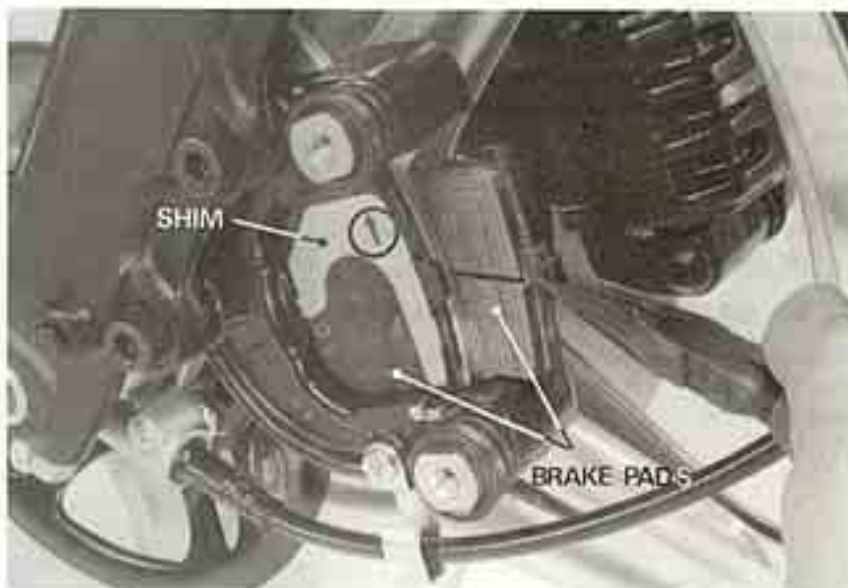
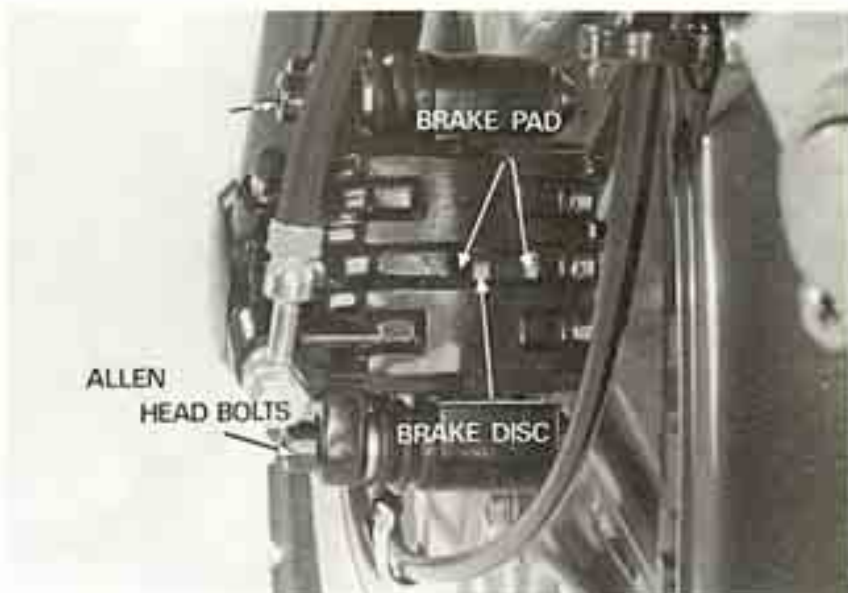

Inspect the piston boot for damage or deterioration.







**HYDRAULIC BRAKE**

Install the brake caliper with the two allen head bolts.

**TORQUE:** 1.5–2.0 kg-m (11–15 ft-lb)

**NOTE**

Torque the bolts evenly in 2-3 steps.



**REAR BRAKE PAD WEAR CHECK**

Replace the rear brake pads if the red line on the top of the pads reaches the edge of the brake disc.

**NOTE**

Always replace both pads to assure even disc pressure.

**REAR BRAKE PAD REPLACEMENT**

Remove the two caliper allen head bolts. Lift the caliper off and remove both brake pads and shim.

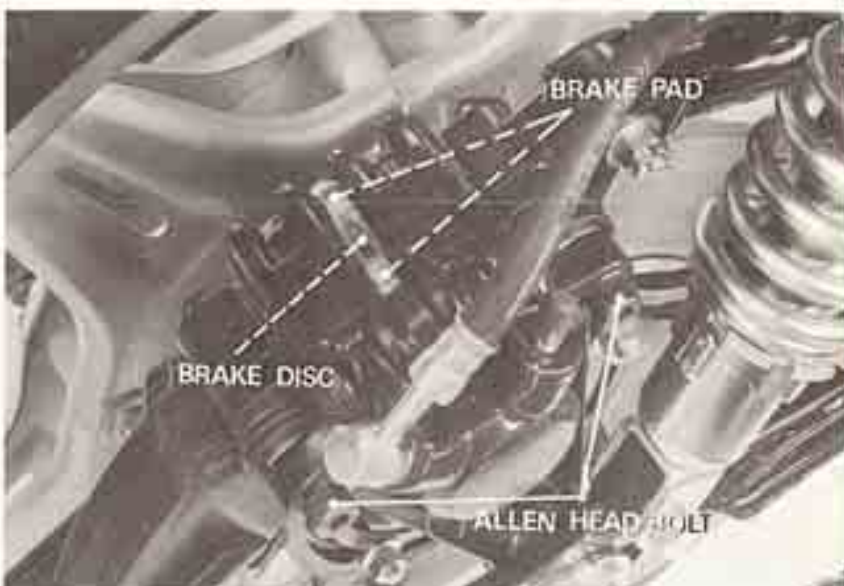

**NOTE**

- Always replace the brake pads in pairs to assure even disc pressure.
- Install the shim on the piston side with the "↑" in the direction of normal wheel rotation.

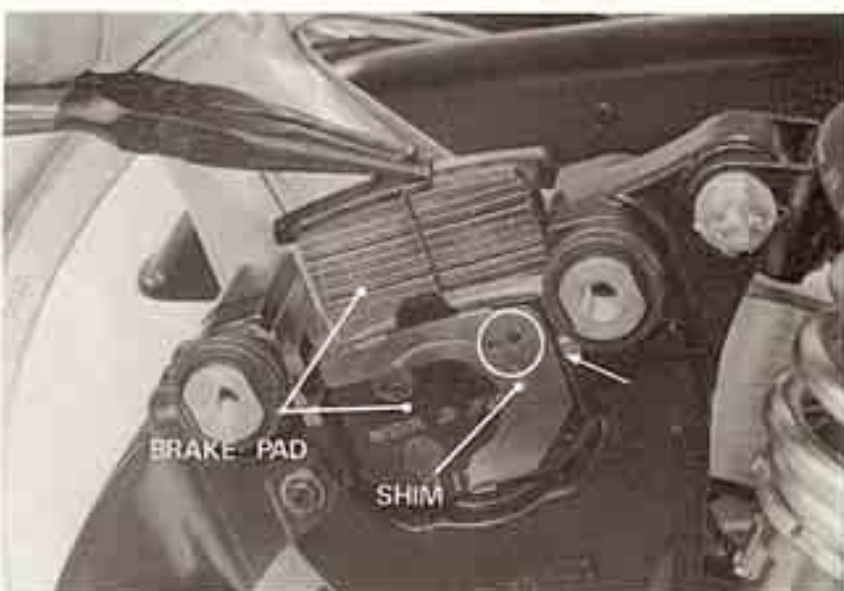



Press the piston back into the caliper. Check the brake fluid level in the brake master cylinder reservoir as this causes the level to rise.

Inspect the piston boot for damage or deterioration.

Insert the pin through the caliper bracket with the chamfered end facing as shown.

Inspect the condition of the dust covers.

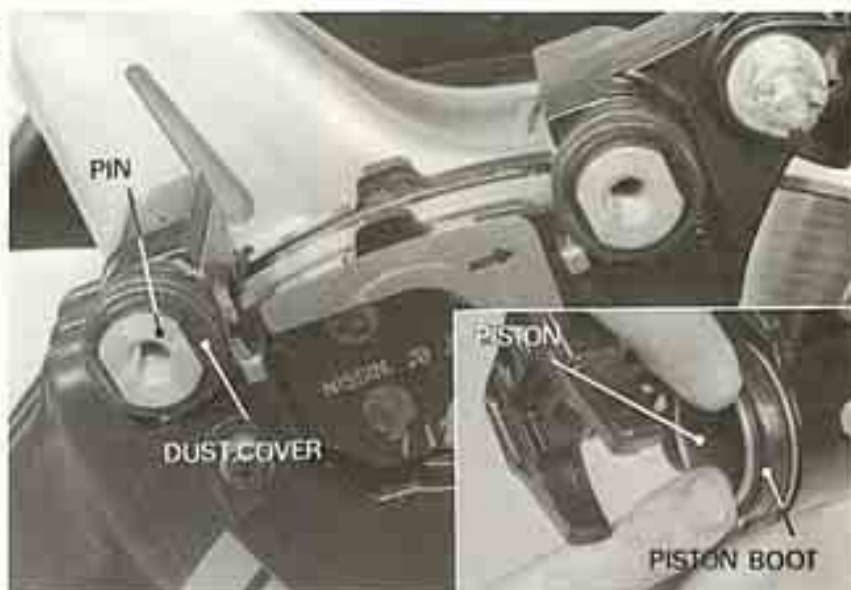

Install the brake caliper with the two allen bolts.

### NOTE

Torque the bolts evenly in 2-3 steps.

**TORQUE: 1.5-2.0 kg-m (11-15 ft-lb)**



### DISC THICKNESS

Measure the disc thickness.

### SERVICE LIMIT:

**FRONT: 4.0 mm (0.16 in)**

**REAR: 6.0 mm (0.24 in)**







**HYDRAULIC BRAKE**

**BRAKE DISC WARPAGE**

Measure brake disc warpage.

**SERVICE LIMIT: 0.3 mm (0.012 in)**



**FRONT MASTER CYLINDER**

**FRONT BRAKE MASTER CYLINDER DISASSEMBLY**

Drain brake fluid from the hydraulic system. Remove the brake lever and rear view mirror from the master cylinder. Disconnect the brake hose.

**CAUTION**

*Avoid spilling brake fluid on painted surfaces.  
Place a rag over the fuel tank whenever the brake system is serviced.*

**NOTE**

*When removing the oil bolt, cover the end of the hose to prevent contamination and secure the hose.*



Remove the master cylinder.

Remove the boot.  
Remove the circlip from the master cylinder body.







Remove the stop plate, secondary cup and master piston.  
Then remove the primary cup and spring.

Remove the brake fluid reservoir from the master cylinder body.

Clean the inside of the master cylinder and reservoir with brake fluid.

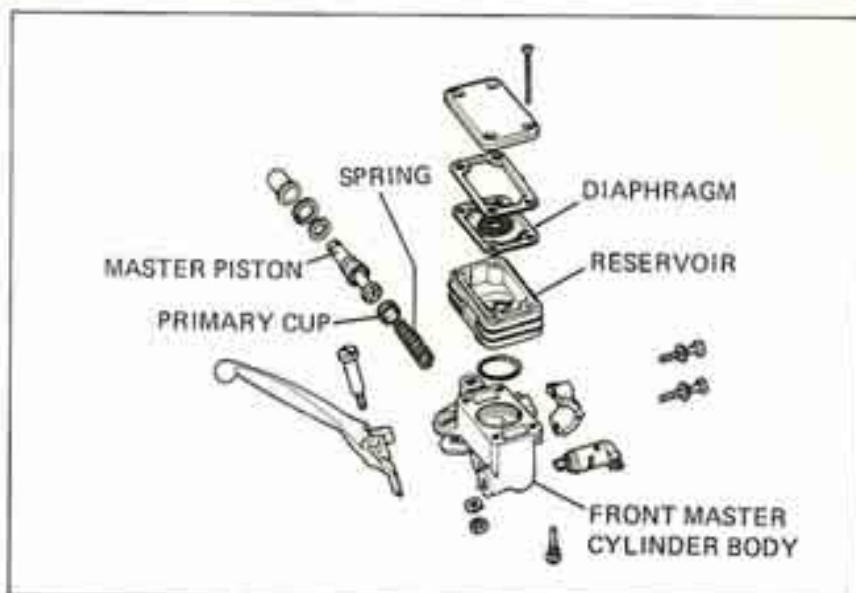

### FRONT MASTER CYLINDER I.D. INSPECTION

Measure the master cylinder I.D.  
Check the master cylinder for scores, scratches or nicks.

**SERVICE LIMIT: 15.925 mm (0.6270 in)**



### FRONT MASTER PISTON O.D. INSPECTION

Measure the master piston O.D.

**SERVICE LIMIT: 15.815 mm (0.6226 in)**

Check the primary cup and secondary cup for damage before assembly.





## HYDRAULIC BRAKE

### FRONT MASTER CYLINDER ASSEMBLY

**CAUTION**

*Handle the master cylinder piston, cylinder and spring as a set.*

Assemble the master cylinder. Coat all parts with clean brake fluid before assembly. Place the spring on the check valve. Install the spring and valve together.

Dip the piston cup in brake fluid before assembly.

**CAUTION**

*When installing the cups, do not allow the lips to turn inside out. Be certain the circlip is seated firmly in the groove.*

Install the boot, washer and clip. Install the reservoir on the master cylinder making sure that the O-ring is in good condition.

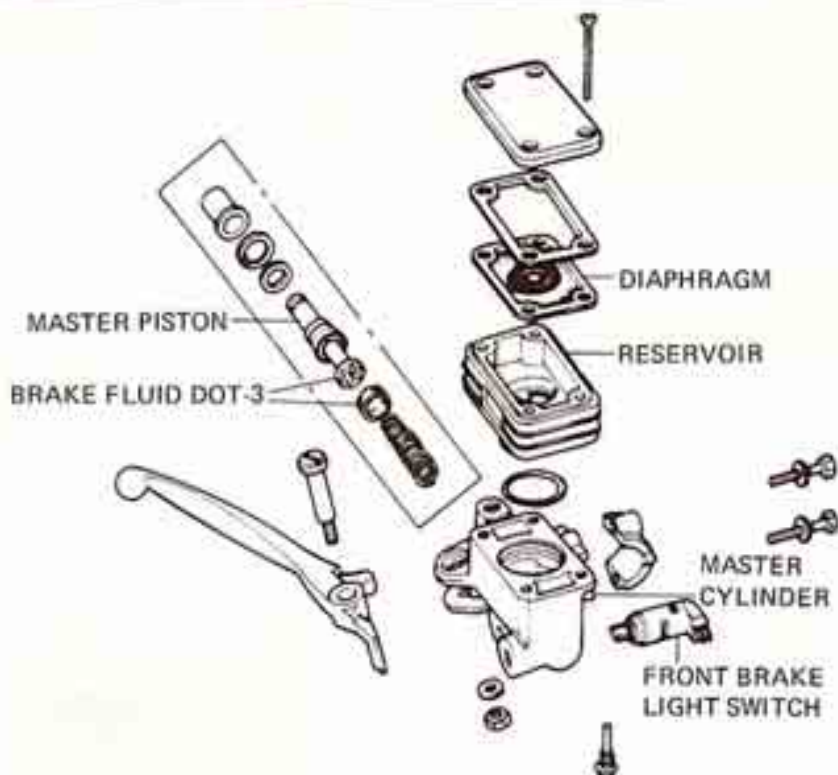

Place the master cylinder on the handlebar and install the holder and the two mounting bolts. Torque the top bolt first. Install the oil hose with the bolt and its two sealing washers. Install the brake lever.

Before installing the lever nut, install the rubber tube from the bottom side of the cylinder, the plate, and nut.

Fill the reservoir to the upper level and bleed the brake system according to page 15-3.





### FRONT BRAKE CALIPER

#### FRONT BRAKE CALIPER DISASSEMBLY

Place a clean container under the caliper and disconnect the brake hose bolt. Loosen the two inside allen bolts. Remove the two outside allen bolts and the caliper.

#### NOTE

Avoid spilling brake fluid on painted surfaces.



Remove the inside allen bolts and separate the two caliper halves. Observe the position of the pad spring. Remove the piston boot and boot clip.



Place a shop towel over the piston to prevent the piston from coming out, and position the caliper with the piston down. Apply a small amount of air pressure to the fluid inlet.

#### WARNING

Do not use high pressure air or bring the nozzle too close to the inlet.

Examine the piston and cylinder for scoring or scratches and replace if necessary.







**HYDRAULIC BRAKE**

Remove the oil seal by first pushing it into the cylinder as shown.  
Clean the caliper grooves with brake fluid.



**FRONT CALIPER PISTON O.D. INSPECTION**

Check the piston for scoring or scratches. Measure the outside diameter of the piston with a micrometer.

**SERVICE LIMIT: 42.765 mm (1.6837 in)**



**FRONT CALIPER CYLINDER I.D. INSPECTION**

Check the caliper cylinder for scoring or scratches. Measure the inside diameter of the caliper cylinder bore.

**SERVICE LIMIT: 42.915 mm (1.690 in)**





### FRONT BRAKE CALIPER ASSEMBLY

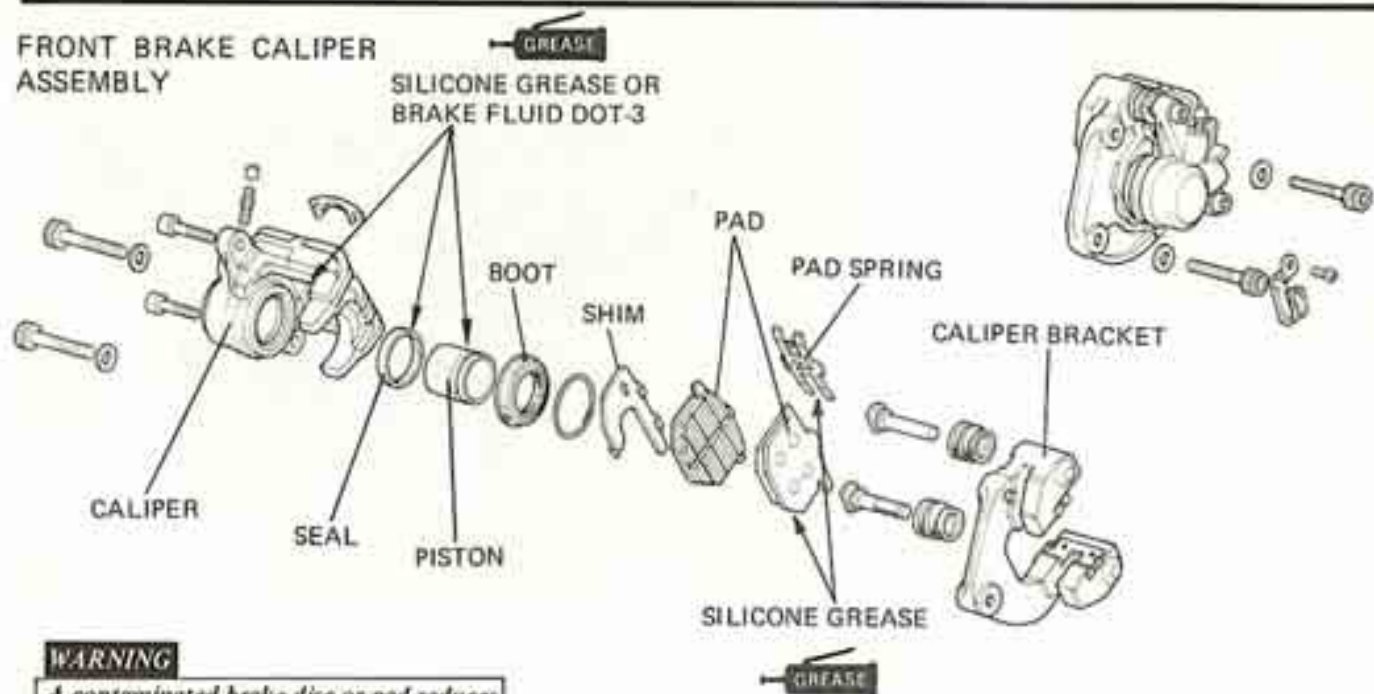

#### **WARNING**

*A contaminated brake disc or pad reduces stopping power. Do not allow grease on the brake pads.*

Assemble the caliper in the reverse order of disassembly. The oil seal must be replaced with a new one whenever removed. Lubricate the piston and seal with a medium grade of Hi-Temperature silicone grease or brake fluid before assembly.

Be certain the piston seal is seated in the caliper groove.

Place the piston in the caliper with the boot lip facing out. Install the boot and clip on the piston.

Install the front brake caliper assembly (page 15-5).

Install the outside allen bolts. Install the oil bolt and the two sealing washers.

Fill the brake fluid reservoir and bleed the front brake system (page 15-4).





**HYDRAULIC BRAKE**

**FRONT CALIPER BRACKET  
DISASSEMBLY**

Remove the speedometer cable clamp.

Remove the two caliper bracket attaching bolts and remove the brake caliper.

Remove the pins and dust covers from the caliper bracket, making sure that they are in good condition.



**FRONT CALIPER BRACKET  
ASSEMBLY**

Wash all removed parts with brake fluid. Make sure that both pins move freely in and out of the caliper pin holes. Lubricate both pins with a medium grade Hi-Temperature silicone grease before assembly.

Install the caliper bracket on the front fork.

**TORQUE: 3.0-4.0 kg-m (22-29 ft-lb)**

Install the front caliper (page 15-5).

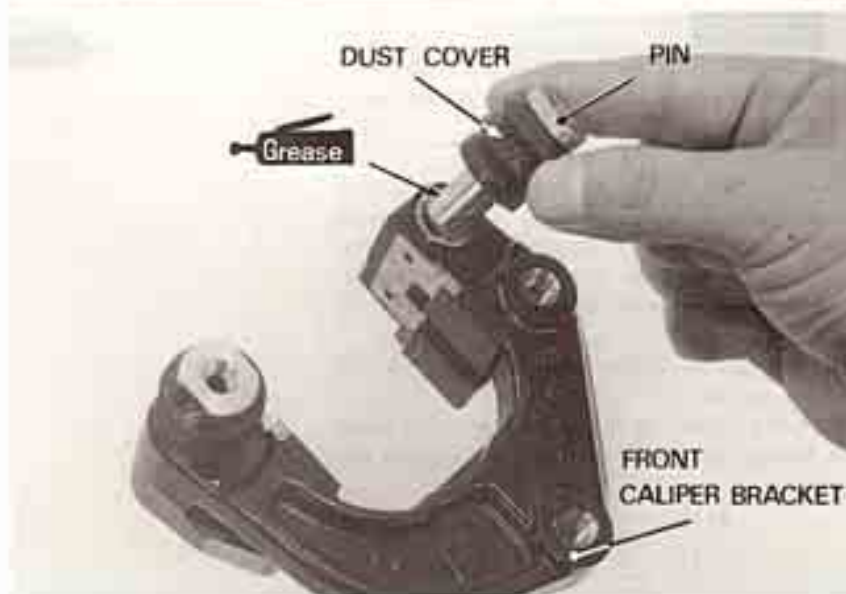

**REAR BRAKE MASTER CYLINDER**

**REAR MASTER CYLINDER  
DISASSEMBLY**

Remove the right side cover.

Place a clean drip pan under the brake line. Disconnect the brake line on the back of the master cylinder.

**CAUTION**

*Avoid spilling brake fluid on painted surfaces.*







Remove the pin from the rod eye and remove the two allen head bolts.

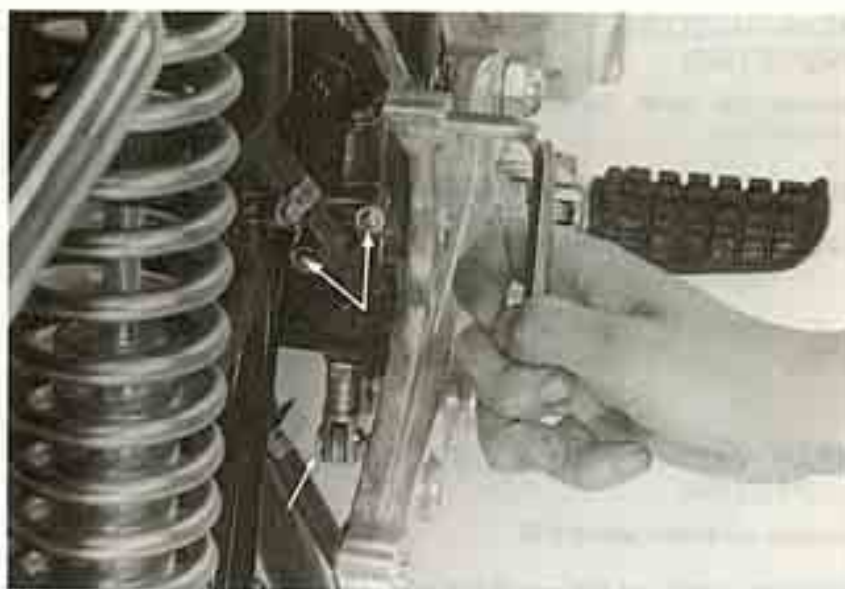

Remove the rubber cover.  
Remove the circlip and push rod from the master cylinder body.



Remove the master piston, primary cup and spring.

It may be necessary to apply a small amount of air pressure to the fluid outlet to remove the master piston and primary cup.

Clean all parts with brake fluid.

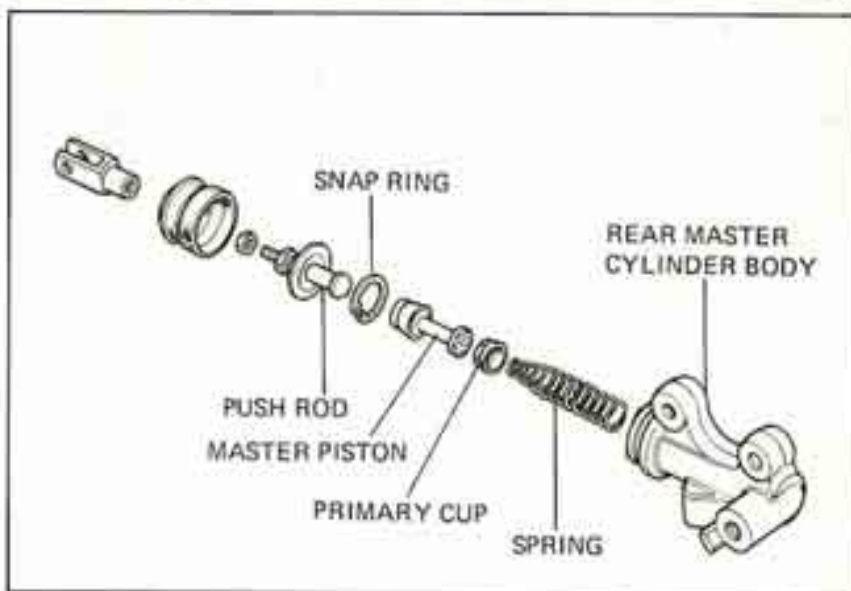



**HYDRAULIC BRAKE**

**REAR MASTER CYLINDER I.D. INSPECTION**

Measure the inside diameter of the master cylinder bore.

**SERVICE LIMIT: 14.06 mm (0.554 in)**

Check for scores, scratches or nicks.



**REAR MASTER PISTON O.D. INSPECTION**

Measure the master piston O.D.

**SERVICE LIMIT: 13.945 mm (0.549 in)**

Check the primary cup and secondary cup for damages before assembly.



**REAR MASTER CYLINDER ASSEMBLY**

**CAUTION**

*Handle the master cylinder piston, cylinder and spring as a set.*

Assemble the master cylinder.  
Coat all parts with clean brake fluid.

Dip the piston cup in brake fluid before assembly.

**CAUTION**

*When installing the cups, do not allow the lips to turn inside out. Be certain the snap ring is seated firmly in the groove.*

Install the primary cup and piston.  
Install the push rod and circlip.  
Install the boot, nut and rod eye.

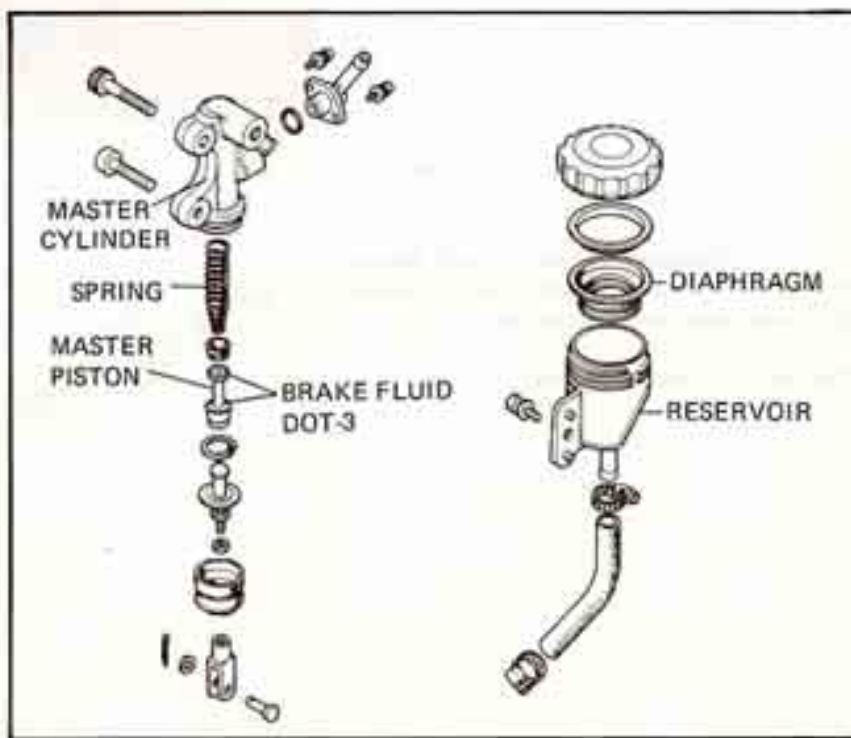



Install the master cylinder on the master cylinder bracket.

**TORQUE:** 3.0–4.0 kg-m (22–29 ft-lb)

Connect the brake hose and brake rod.

Bleed the brake hydraulic system after assembly. (Page 15-14)



### REAR BRAKE CALIPER

#### REAR BRAKE CALIPER REMOVAL

Drain the brake hydraulic system.  
Disconnect the brake hose.

#### NOTE

Avoid spilling brake fluid on painted surfaces and the brake.

Remove the two brake caliper bolt and caliper.

#### REAR BRAKE CALIPER DISASSEMBLY

Refer to Front Brake Caliper. (Page 15-10)



#### REAR BRAKE CALIPER PISTON O.D. INSPECTION

Check the piston for scoring or scratches.  
Measure the piston diameter.

**SERVICE LIMIT:** 38.09 mm (1.50 in)







## HYDRAULIC BRAKE

### REAR BRAKE CALIPER CYLINDER I.D. INSPECTION

Check the caliper cylinder for scoring or scratches.

Measure the inside diameter of the caliper cylinder bore.

**SERVICE LIMIT: 38.240 mm (1.506 in)**



### REAR BRAKE CALIPER ASSEMBLY

Apply a thin coat of medium grade Hi-Temperature silicone grease or brake fluid to the piston and seal.

#### **WARNING**

*A contaminated brake disc or pad reduces stopping power. Do not allow grease to contact pad faces.*

Install the piston seats, pistons, boots and clips.

Install the shims, pads, pins and spring. The arrows on the shims must be pointing down when the caliper is positioned.

Replace the seal between the two caliper halves with a new one.

Align both caliper halves and torque the two allen bolts.

**TORQUE: 1.5–2.0 kg-m (11–15 ft-lb)**

Install the brake line and position the caliper.

Install the rear axle, axle nut and the caliper stay bolt. Torque the stay bolt, then the axle nut.

Install the cotter pin.

**CALIPER STAY BOLT TORQUE:**

1.8–2.5 kg-m (13–18 ft-lb)

**REAR AXLE TORQUE:**

8.0–10.0 kg-m (57.9–72.3 ft-lb)

Fill the reservoir to the upper level and bleed the rear brake system. (Page 15-3)

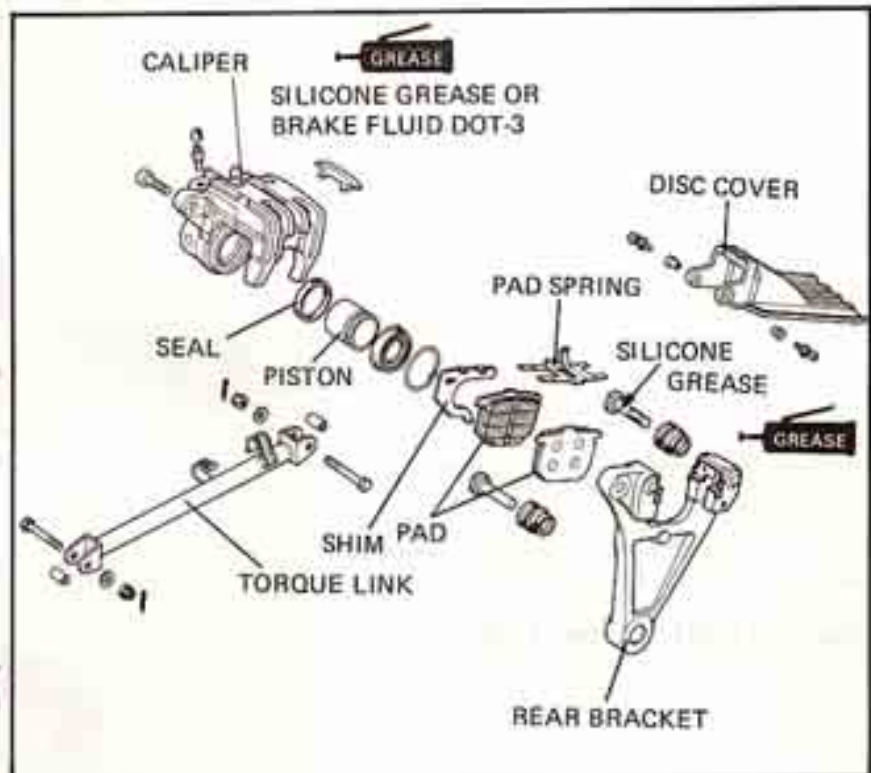



### REAR CALIPER BRACKET DISASSEMBLY

Remove the two bolts holding the caliper bracket.

Remove the axle nut and remove the caliper bracket from the rear swing arm.

Remove the pins and dust cover and check for damage.



### REAR CALIPER BRACKET ASSEMBLY

Make sure that both pins move freely in and out of the caliper pin holes.

Lubricate both pins with a medium grade Hi-Temperature Silicone grease before assembly.

Install the caliper brake on the swing arm.

**TORQUE: 8.0–10.0 kg-m (58–72 ft-lb)**

Install the rear caliper according to page 15–18.

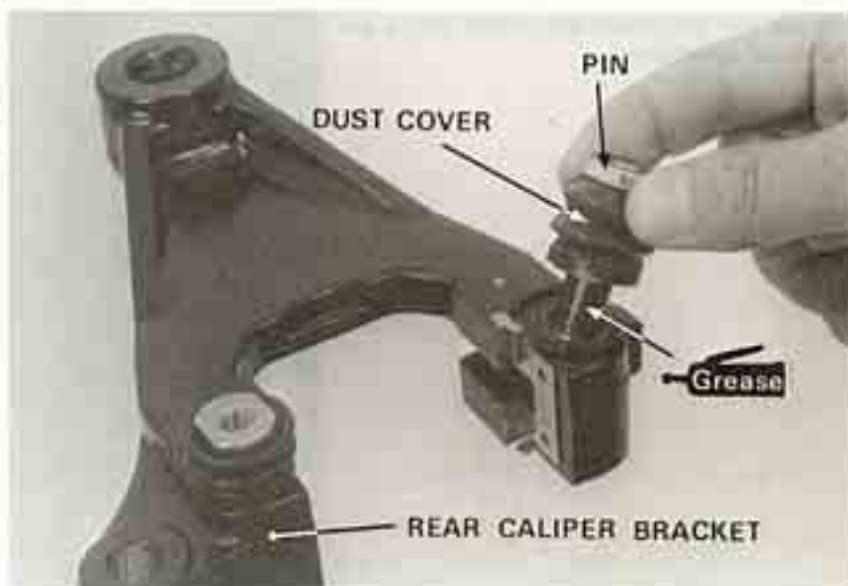



## BRAKE PEDAL SHAFT

### BRAKE PEDAL SHAFT REMOVAL/ INSTALLATION

#### NOTE

The brake pedal shaft can be removed and installed without removing the muffler.

Remove the brake pedal.

Remove the allen head bolt and rod pin.  
Remove the rear master cylinder.



Remove the rear brakelight switch spring and rear brake pedal shaft.

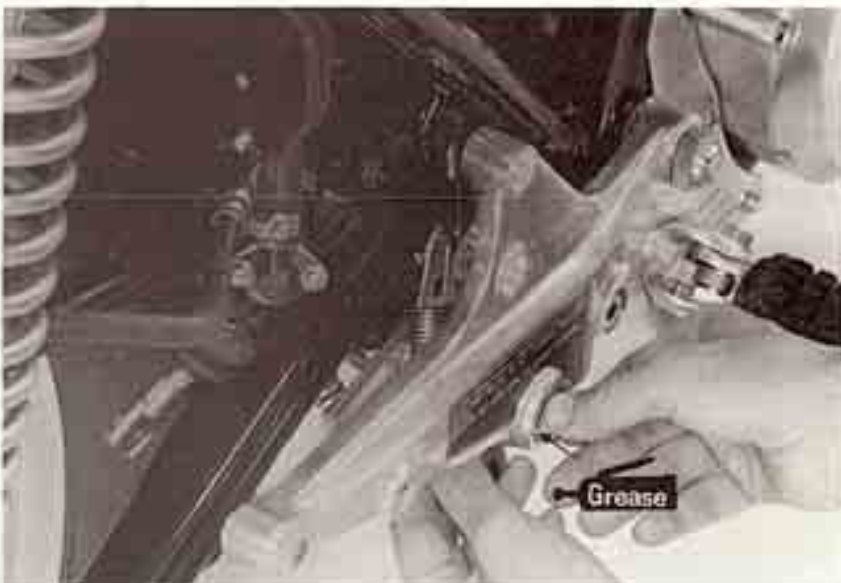

Install the brake return spring as shown.







**BATTERY/CHARGING SYSTEM**

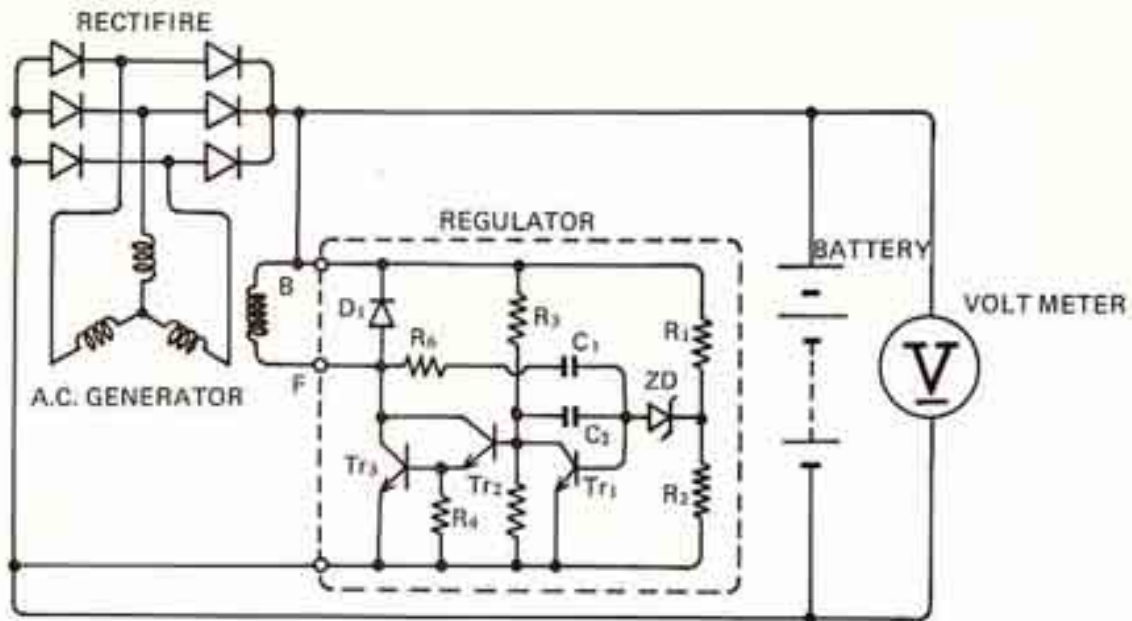

**BATTERY/CHARGING SYSTEM**

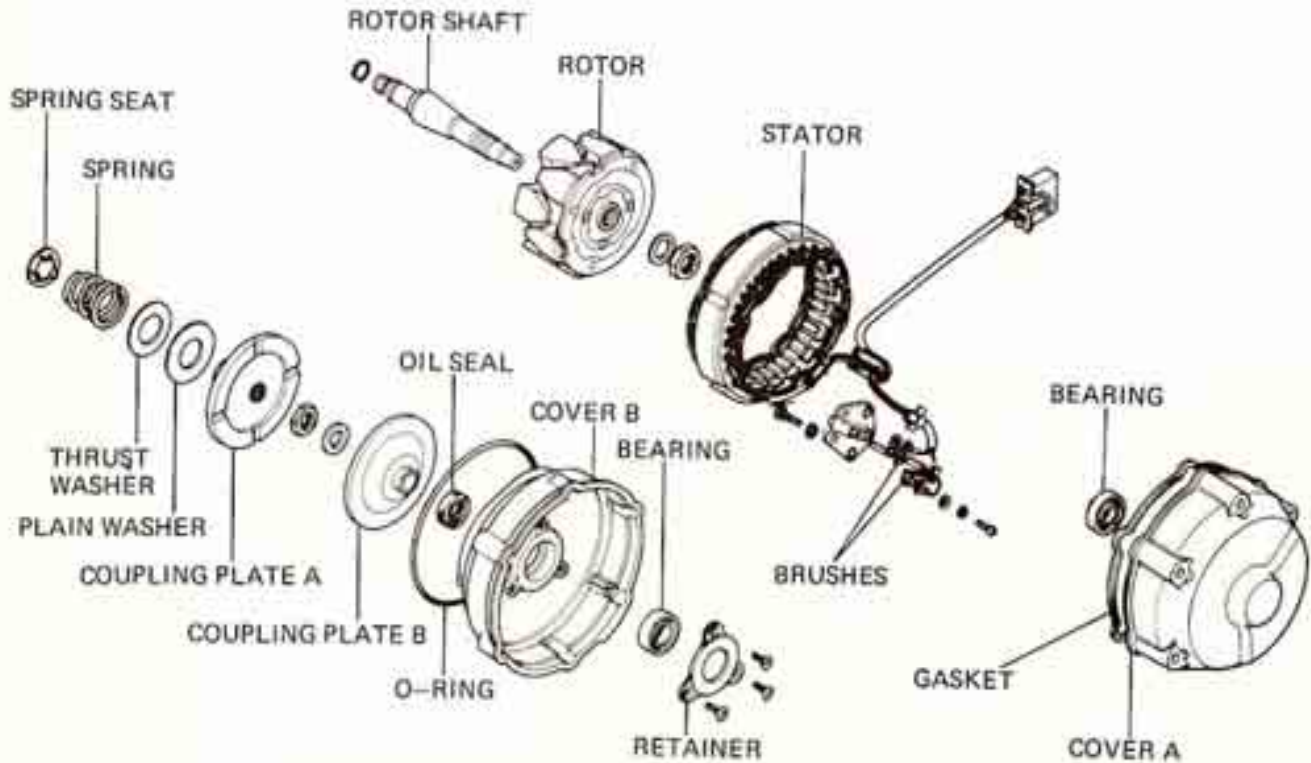

**A.C. GENERATOR**



SERVICE INFORMATION	16-1
TROUBLESHOOTING	16-2
BATTERY	16-3
CHARGING SYSTEM	16-4
A. C. GENERATOR REMOVAL/ INSTALLATION	16-5
VOLTAGE REGULATOR	16-9

## SERVICE INFORMATION

### WORKING PRACTICE

Battery fluid level should be checked regularly and filled with distilled water when necessary.

When charging the battery, quick-charging should only be done in an emergency; slow-charging is preferred.

Remove the battery from the motorcycle for charging. If battery must be charged on the motorcycle, disconnect the battery cables.

Keep flames or sparks away from a charging battery because it produces hydrogen.

All charging system components can be tested on the motorcycle.

### SPECIAL TOOLS

#### Common tools

Bearing Driver Handle	07749-0010000
Bearing Driver (32 x 35)	07746-0010100
Bearing Driver (37 x 40)	07746-0010200

### SPECIFICATIONS

Battery	Capacity	12V 18AH		
	Specific gravity	1.28/20° C (68° F)		
	Charging rate	1.8 amperes maximum		
A. C. generator	Capacity	1000 rpm	1500 rpm	5000 rpm
		5A min.	12A min.	24A min.
Voltage regulator	Transistorized non-adjustable regulator			



## TROUBLESHOOTING

### No Power — Key Turned On:

1. Dead battery
  - Low fluid level
  - Low specific gravity
  - Charging system failure
2. Disconnected battery cable
3. Main fuse burned out
4. Faulty ignition switch

### Low Power — Key Turned On:

1. Weak battery
  - Low fluid level
  - Low specific gravity
  - Charging system failure
2. Loose battery connection

### Low Power — Engine Running:

1. Battery undercharged
  - Low fluid level
  - One or more dead cells
2. Charging system failure

### Intermittent Power:

1. Loose battery connection
2. Loose charging system connection
3. Loose starting system connection
4. Loose connection or short circuit in ignition system
5. Loose connection or short circuit in lighting system

### Charging System Failure:

1. Loose, broken, or shorted wire or connection
2. Faulty voltage regulator
3. Faulty silicon rectifier
4. Faulty A.C. generator





### BATTERY

#### REMOVAL

Remove the right and left side covers.  
 Disconnect the ground cable at the battery terminal.  
 Disconnect the positive cable at the magnetic switch terminal.  
 Remove the battery holder.

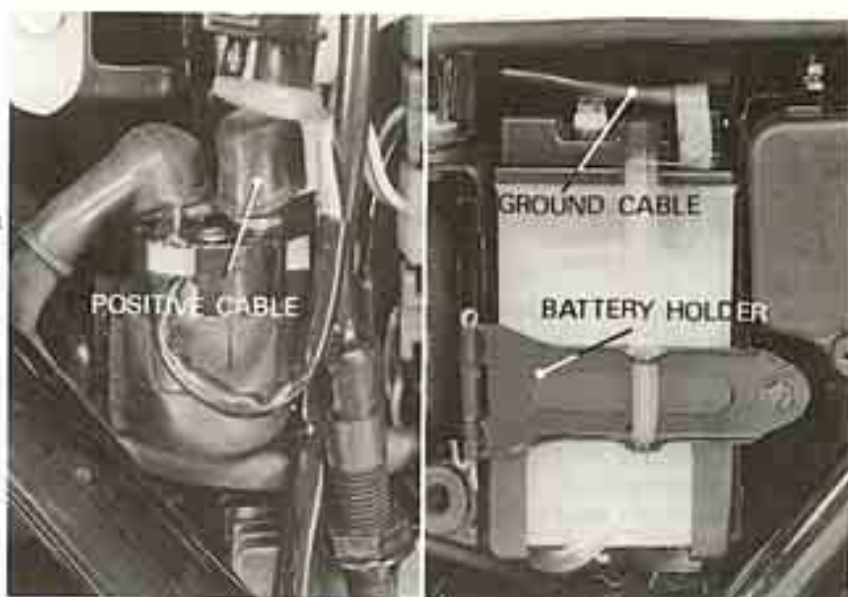

#### TESTING SPECIFIC GRAVITY

Test each cell with a hydrometer.

**SPECIFIC GRAVITY:**  
 (20°C, 68°F)

1.27–1.29	Fully charged
Below 1.26	Undercharged

#### NOTE

- The battery must be recharged if the specific gravity is below 1.23.
- The specific gravity varies with the temperature as shown in the accompanying table.
- Replace the battery if sulfation is evident.
- The battery must be replaced if there are pastes settled on the bottom of each cell.

#### WARNING

*The battery contains sulfuric acid.  
 Avoid contact with skin, eyes, or clothing.  
 Antidote: Flush with water and get prompt medical attention.*

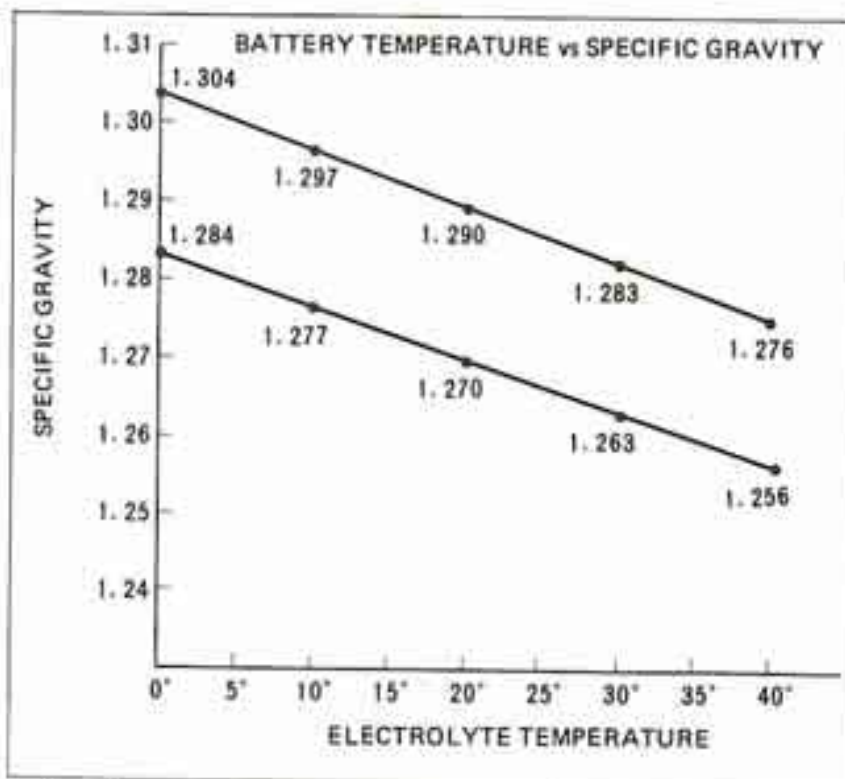

Specific gravity changes by 0.007 for every 10°C.



## BATTERY/CHARGING SYSTEM

### BATTERY CHARGING

Connect the charger positive (+) cable to the battery positive (+) terminal.  
Connect the charger negative (-) cable to the battery negative (-) terminal.

**Charging current:**  
1.8 amperes max.

**Charging:**  
Charge the battery until specific gravity is 1.27-1.29 at 20°C (68°F).

#### WARNING

- Before charging a battery, remove the cap from each cell.
- Keep flames and sparks away from a charging battery.
- Turn power ON/OFF at the charger, not at the battery terminals.
- Discontinue charging if the electrolyte temperature exceeds 45°C (113°F).

#### CAUTION

Quick-charging should only be done in an emergency; slow-charging is preferred.

After installing the battery, coat the terminals with clean grease.

#### CAUTION

Route the breather tube as shown on the battery caution label.

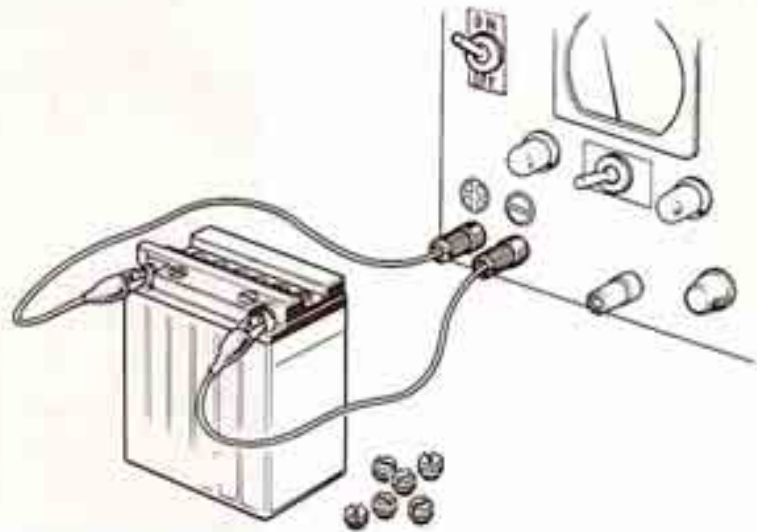

CARBURETOR  
OVERFLOW TUBE

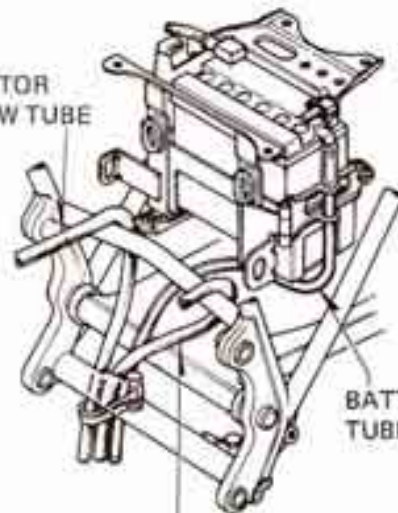

BATTERY BREATHER  
TUBE

AIR CLEANER DRAIN TUBE

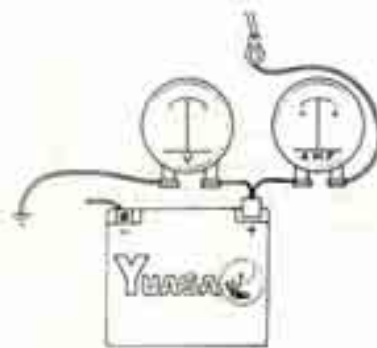

### CHARGING SYSTEM

#### CHARGING OUTPUT TEST

Warm up the engine before taking readings.  
Connect a voltmeter and an ammeter to check charging system output.

#### NOTE

Use a fully charged battery to check the charging system output.

#### TECHNICAL DATA

MAIN SWITCH	LIGHTING SWITCH	INITIAL CHARGING	AT 5,000 RPM
ON	ON (High beam)	1,050 rpm	0 amperes minimum/14 volts



## A.C. GENERATOR REMOVAL/ INSTALLATION

Remove the right side cover and disconnect the A.C. generator coupler.

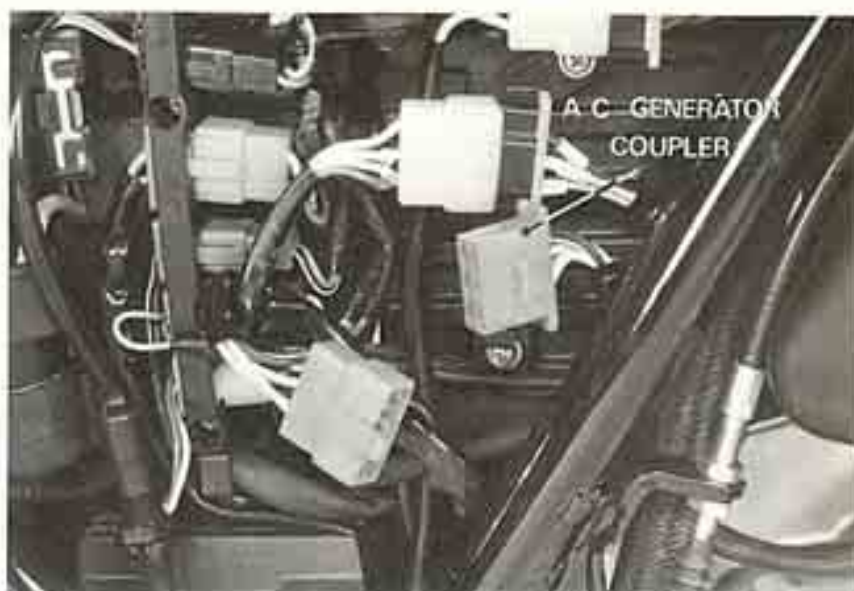

Remove the A.C. generator by loosening three screws.

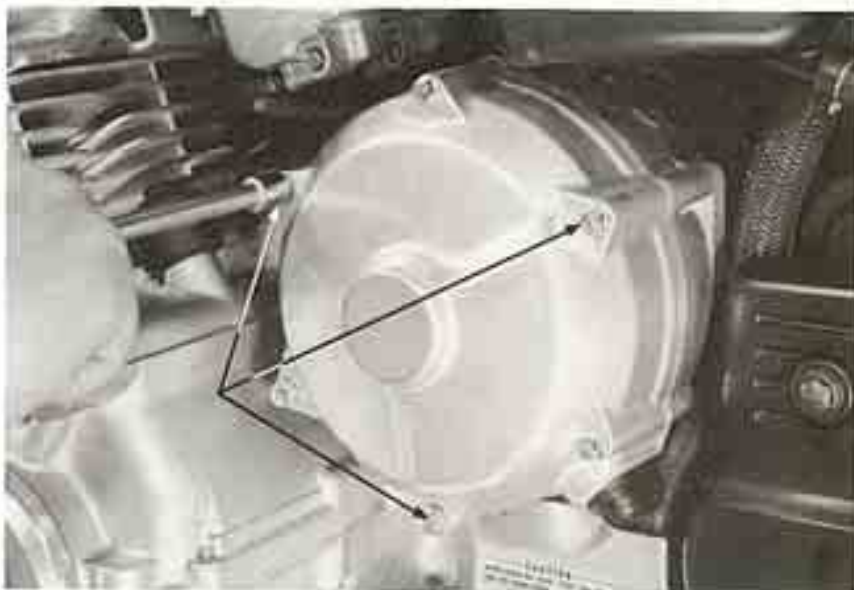

Remove the A.C. generator clutch spring and washer.

Loosen three bolts and disassemble the A.C. generator. (See page 16-0)







**BATTERY/CHARGING SYSTEM**

**INSPECTION**

Inspect the length of each brush as shown. If it shows wear to the scribed service limit line, replace the brush.

**SERVICE LIMIT:** Scribed line

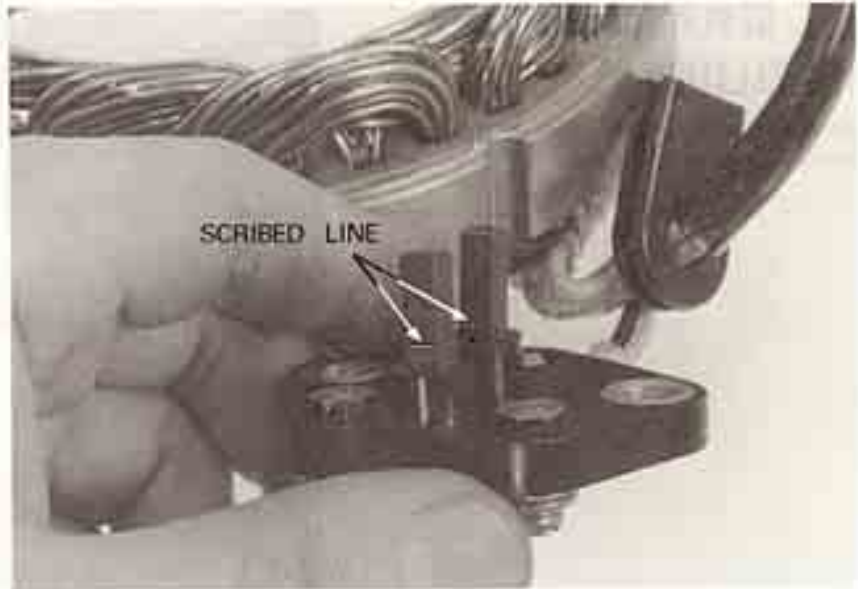

Remove and replace the brushes by removing the mounting screws.

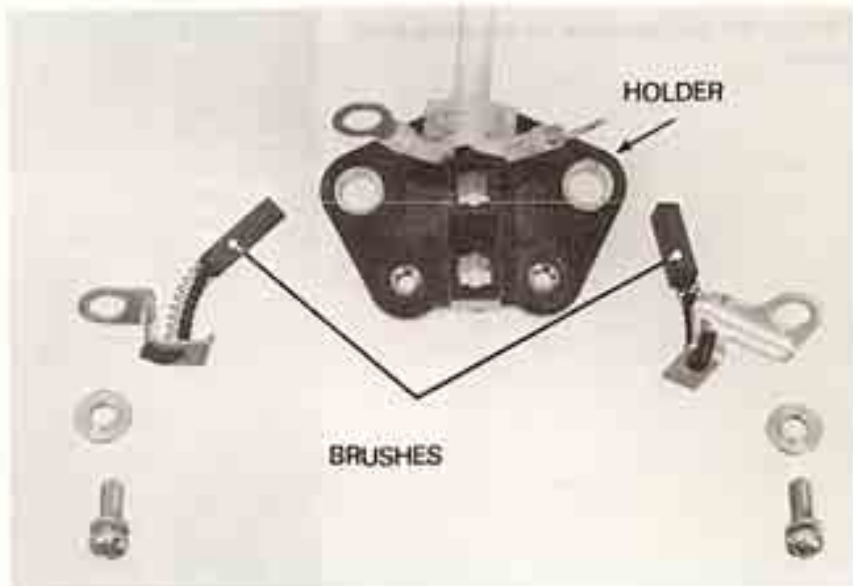



### STATOR COIL CONTINUITY TEST

#### NOTE

It is not necessary to remove the stator to make this test.

Check the yellow leads to the A.C. generator stator for continuity with each other. Replace the stator if any yellow lead is not continuous with the others, or if any lead has continuity to ground.

**SPECIFIED RESISTANCE:** 0.32–0.40Ω



### INSTALLATION

Install a new ball bearing with the bearing driver.

#### NOTE

Drive the outer race evenly.



Install a new bearing into A.C. generator housing with the bearing driver.





Install a new oil seal with the bearing driver.

**CAUTION**

*When installing the A. C. generator, apply molybdenum disulfide grease to sliding surface of the couplings of the A. C. generator.*





### VOLTAGE REGULATOR

#### VOLTAGE REGULATOR PERFORMANCE TEST

##### a. Testing with a voltmeter

Connect a voltmeter across the battery.  
Check regulator performance with the engine running.

Regulator must cut off the field coil current when battery voltage reaches 14–15V.

##### b. Testing with a variable resistor

Connect two 12V batteries in series.  
Connect a variable resistor (0–100Ω) across the battery with a 50Ω resistor in between.  
Test lamp must go out when voltage reaches 14–15V on the voltmeter by adjusting the variable resistor.

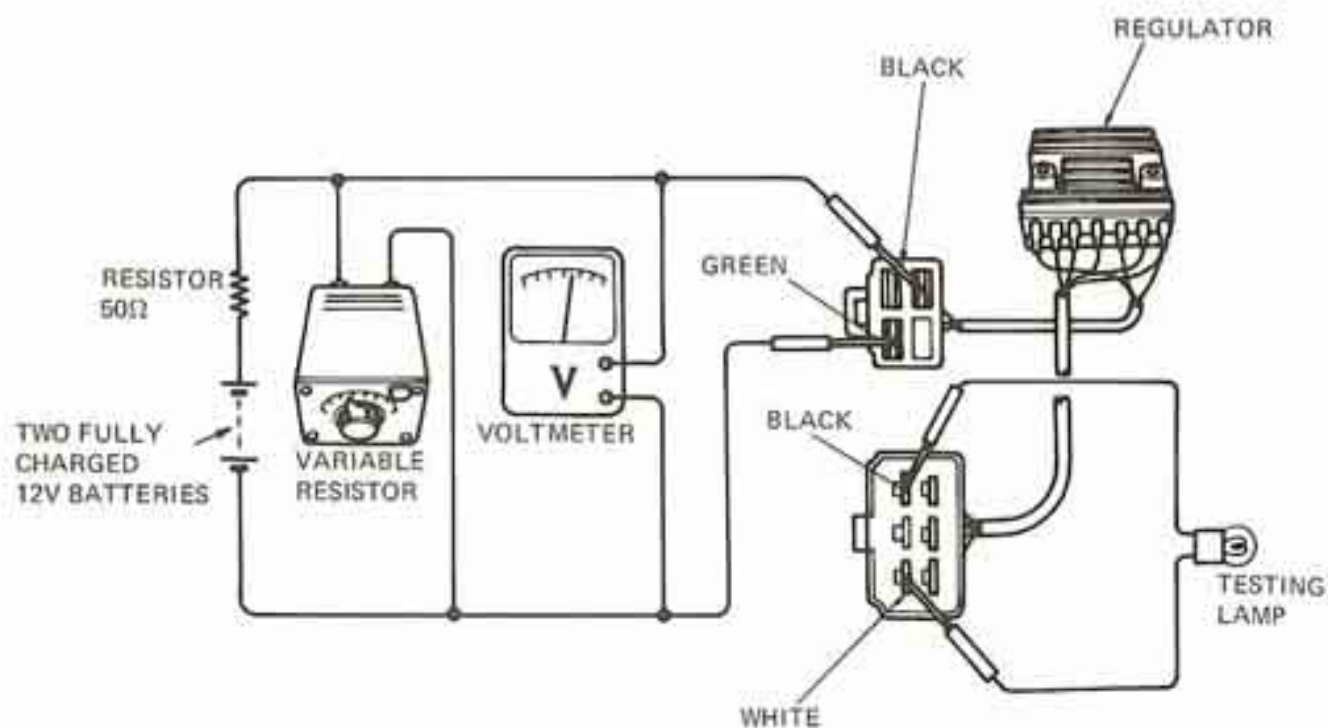
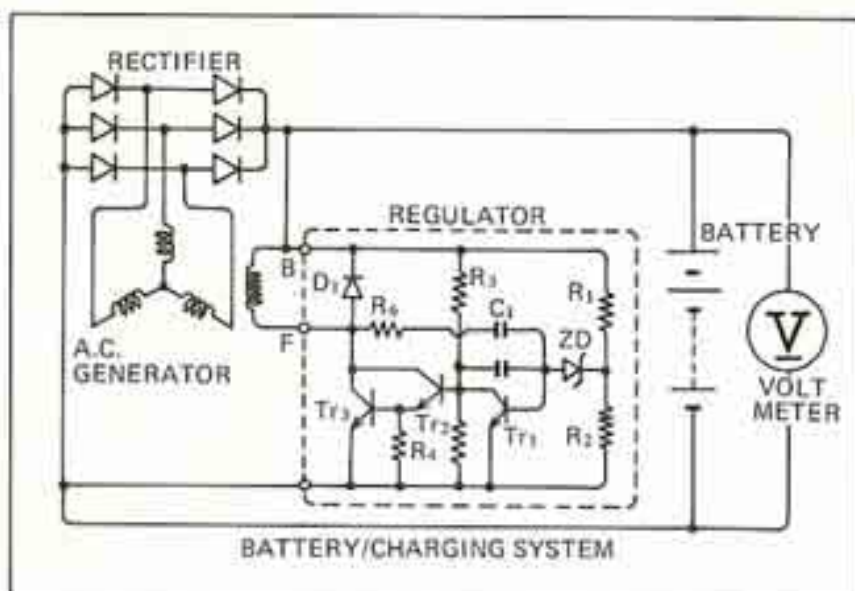



**VOLTAGE REGULATOR/  
RECTIFIER TEST**

Check the resistance between the leads with an ohmmeter.

**RESISTANCE IN NORMAL DIRECTION:**

Green lead and any yellow lead: 5-40Ω

Red/white lead and any yellow lead: 5-40Ω

**RESISTANCE IN REVERSE DIRECTION:**

Red/white lead and any yellow lead: 2000Ω min.

Green lead and any yellow lead: 2000Ω min.

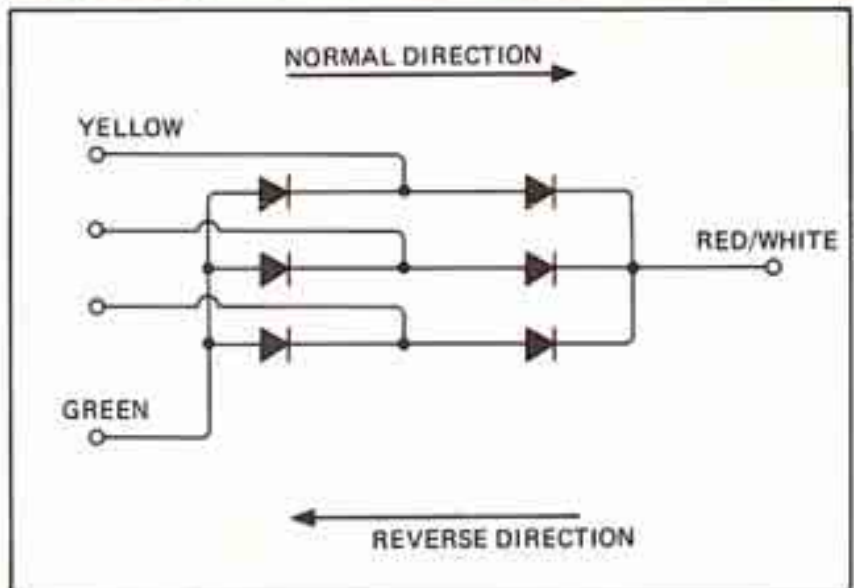
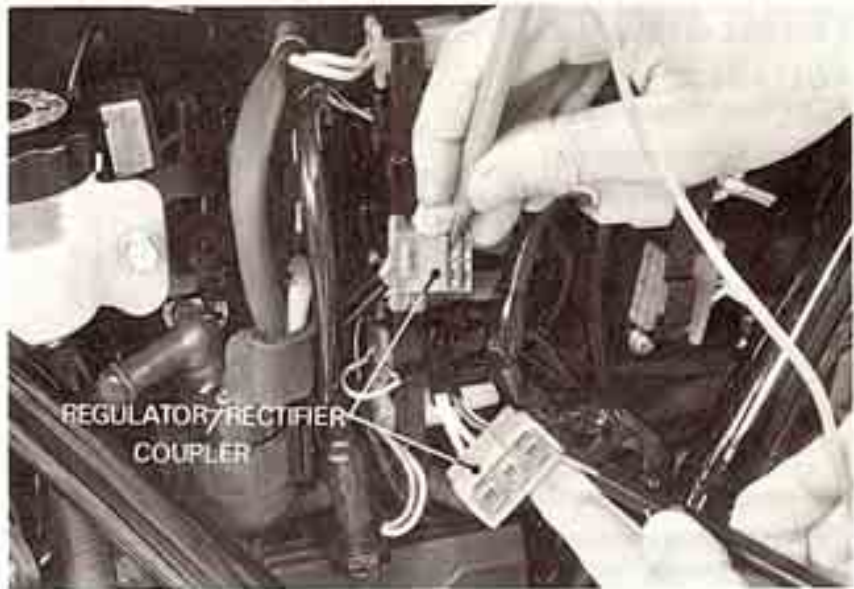



SERVICE INFORMATION	17-1
TROUBLESHOOTING	17-2
IGNITION COIL	17-3
TRANSISTORIZED IGNITION SYSTEM (Pulser Generator, Spark Unit)	17-4

## SERVICE INFORMATION

### WORKING PRACTICE

A TRANSISTORIZED IGNITION SYSTEM is used and no adjustments are to be made unless the pulser generator screws are loosened. If these screws are loosened, ignition timing for either the No. 1 or No. 6 cylinder must be adjusted. For spark plug information, see page 3-4.

### SPECIFICATIONS

		For cold climate (below 5° C)	Standard	For extended high speed riding
Spark plug U.S.A. only	ND	X22ES-U	X24ES-U	X27ES-U
	NGK	D7EA	D8EA	D9EA
Spark plug (Canada model)	ND, X24ESR-U NGK DR8ES-L			
Spark plug gap	0.6-0.7 mm (0.024-0.028 in)			
Ignition timing	At idle rpm	10° (BTDC)		
	Partial advance/rpm	23.5°/2500		
	Full advance/rpm	31°/8000		
Ignition coil	3-point spark test	6 mm (0.24 in ) minimum		



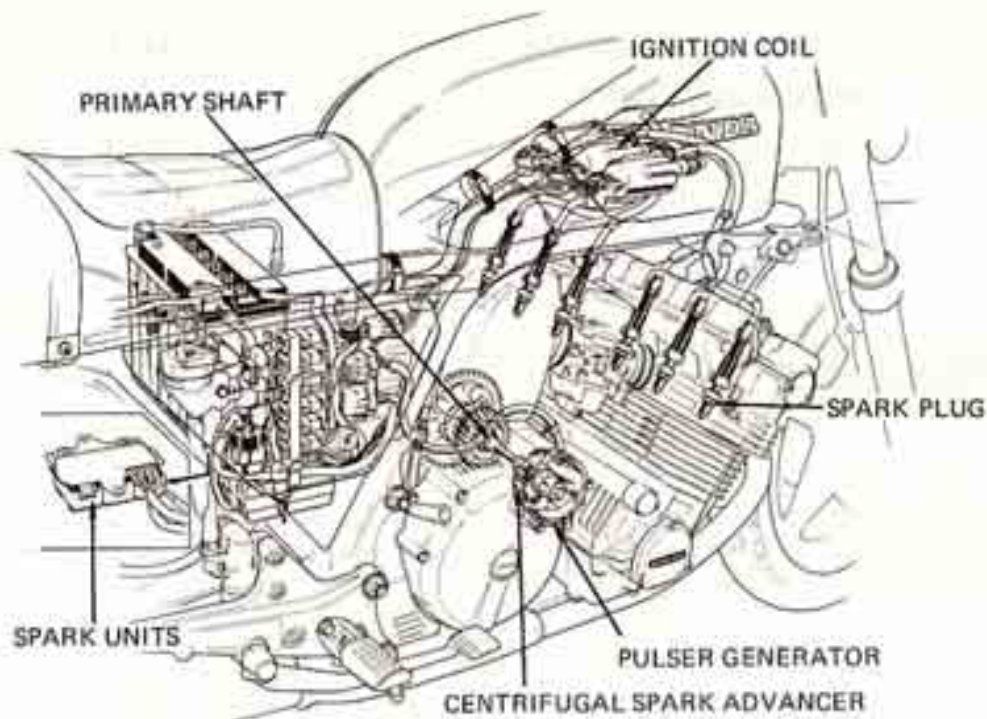

## TROUBLESHOOTING

### NOTE

The ignition system is broken down into three sub-systems; one for No. 1 and No. 6 cylinders, one for No. 2 and No. 5 cylinders and one for No. 3 and No. 4 cylinders. First localize the trouble to one of these sub-systems, then proceed to the more detailed tests as described below.

#### Engine cranks but will not start

- Engine stop switch OFF.
- No spark at plugs
- Faulty transistorized spark unit
- Faulty pulser generator

#### No spark at plug

- Engine stop switch OFF
- Poorly connected, broken or shorted wires
  - Between ignition switch and engine stop switch
  - Between spark unit and engine stop switch
  - Between spark unit and ignition coil
  - Between ignition coil and plug
  - Between spark unit and pulser generator
- Faulty ignition coil
- Faulty ignition switch
- Faulty spark unit
- Faulty pulser generator

#### Engine starts but runs poorly

- Ignition primary circuit
  - Faulty ignition coil
  - Loose or bare wire
  - Intermittent short circuit
- Secondary circuit
  - Faulty plug
  - Faulty high tension cord

#### Timing advance incorrect

- Centrifugal advancer faulty

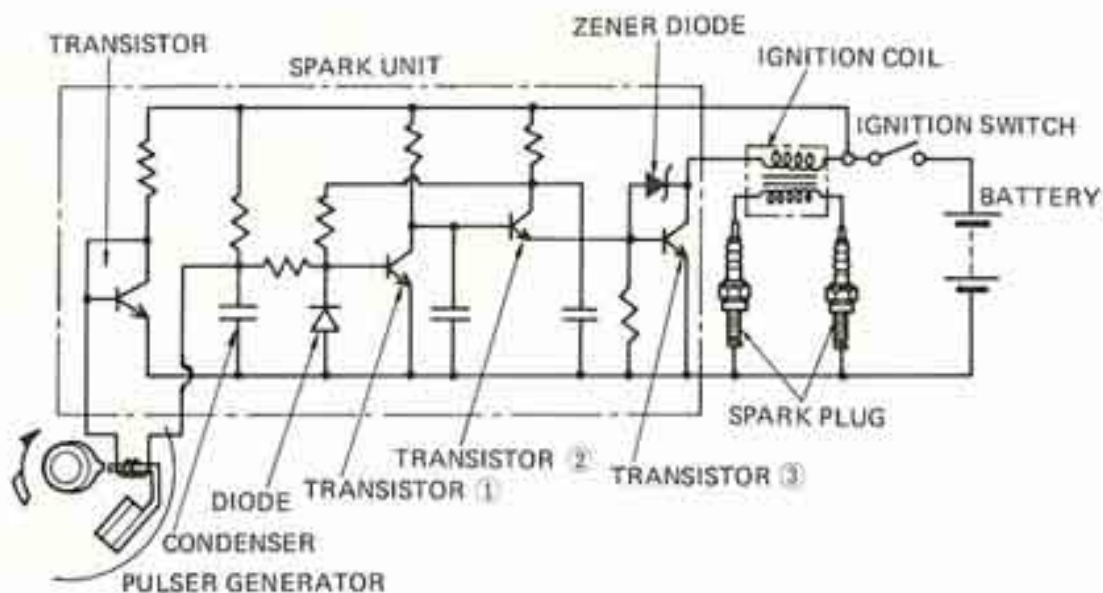

### IGNITION COIL

#### REMOVAL

Remove the fuel tank.  
Disconnect the wire leads.  
Remove the coils by removing the attaching bolts.

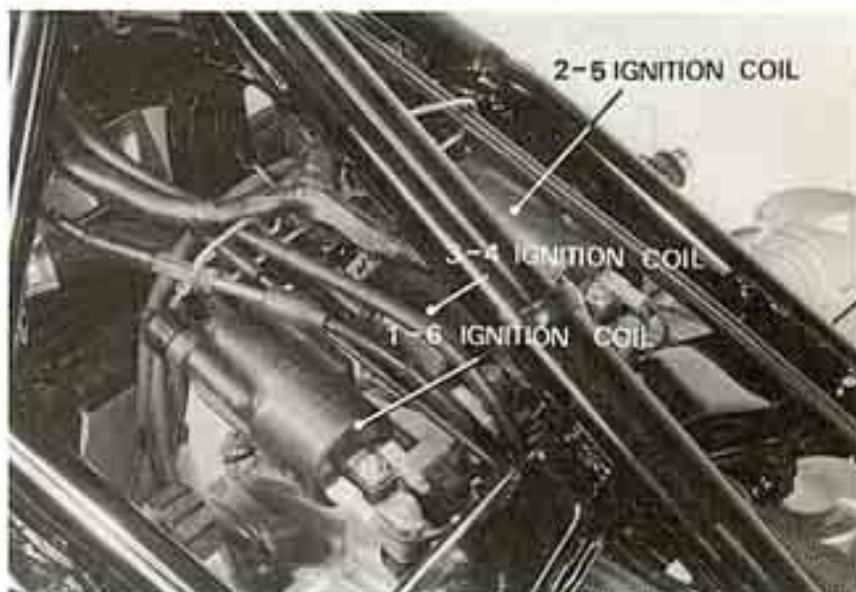
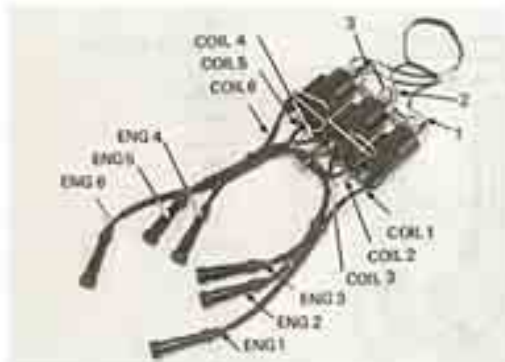

#### PERFORMANCE TEST

Perform the 3-point spark test with a coil tester.

**SERVICE LIMIT: 6 mm (0.24 in) min**

#### NOTE

For wire connection, follow the instructions supplied with the coil tester.

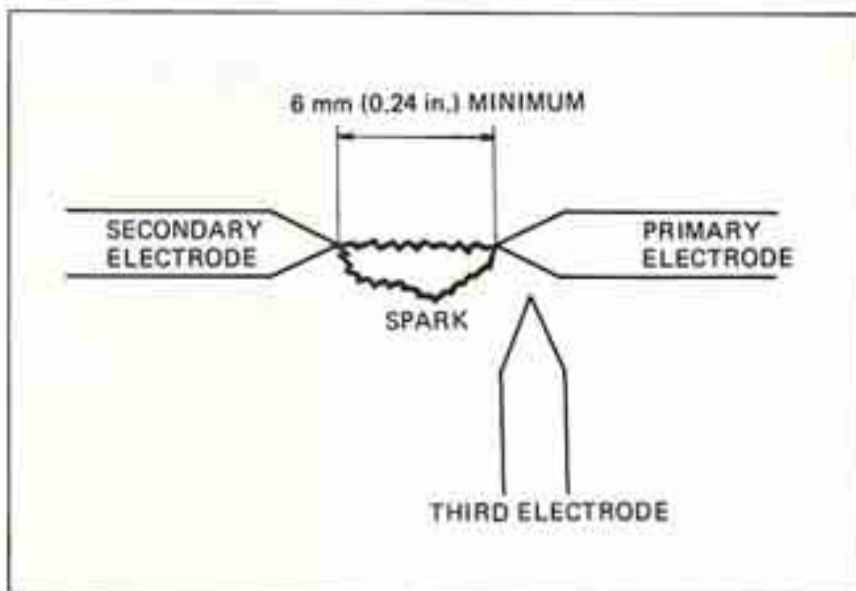





**IGNITION SYSTEM**

**TRANSISTORIZED IGNITION SYSTEM**

**INSPECTION**

**System**

Disconnect the No. 4, 5 and 6 spark plugs.  
 Hold each plug against any convenient engine ground.  
 Turn the ignition switch on.  
 Remove the pulser cover.  
 Touch the end of a screwdriver to the rotor and one pulser generator steel core.  
 Repeat this operation several times.  
 A good spark to the plug means that the ignition system for that cylinder is in good shape.  
 Repeat the above for the other two pulsers.

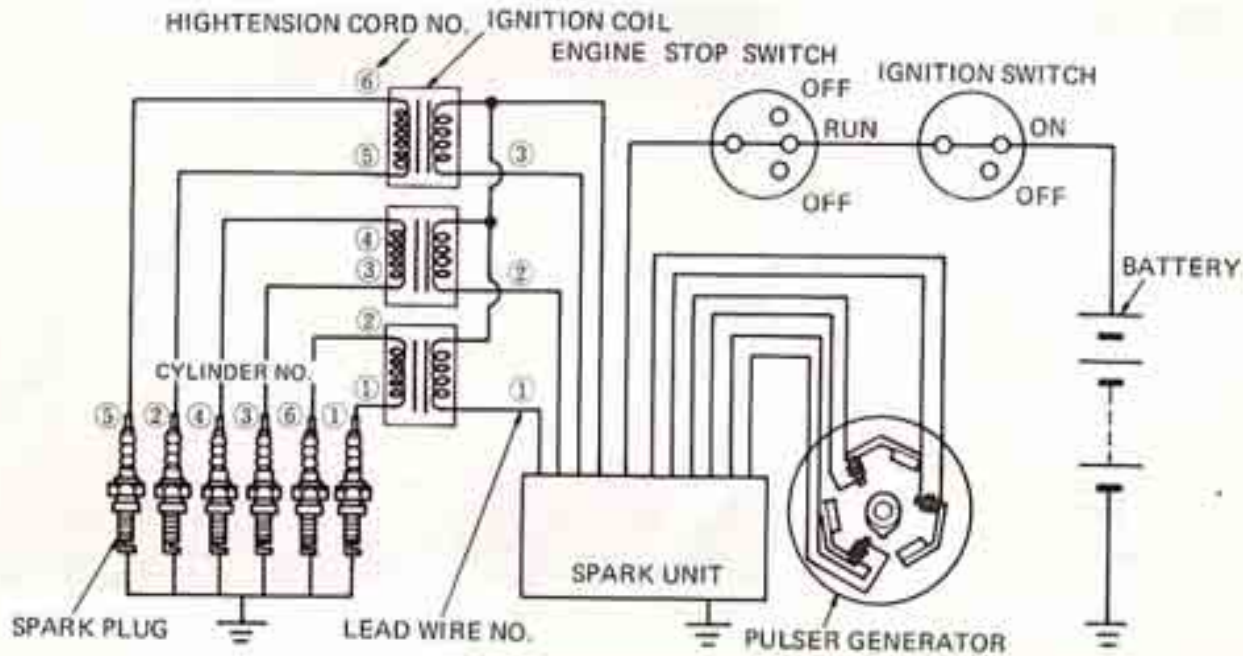

**Pulser generator**

Measure the coil resistance.

**COIL RESISTANCE:  $530 \pm 50\Omega$  ( $20^\circ\text{C}$ ,  $68^\circ\text{F}$ )**

- Between pink leads (3, 4 cylinders)
- Between yellow leads (2, 5 cylinders)
- Between blue leads (1, 6 cylinders)

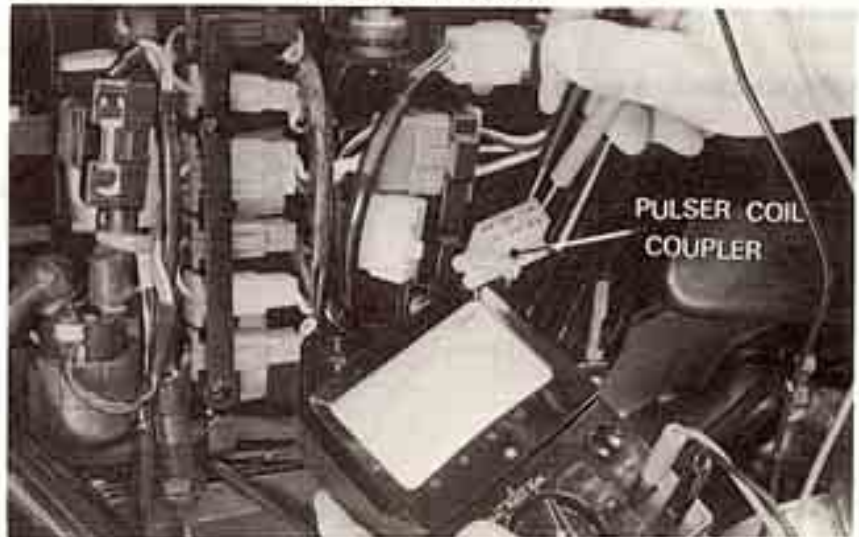





### SPARK UNIT

Disconnect the wirings at the 6-pole coupler.

Attach the positive lead of a voltmeter to each of the three 4-pole coupler terminals (1,6, 2,5 and 3,4). Attach the negative lead to any convenient ground. Turn the ignition switch on,

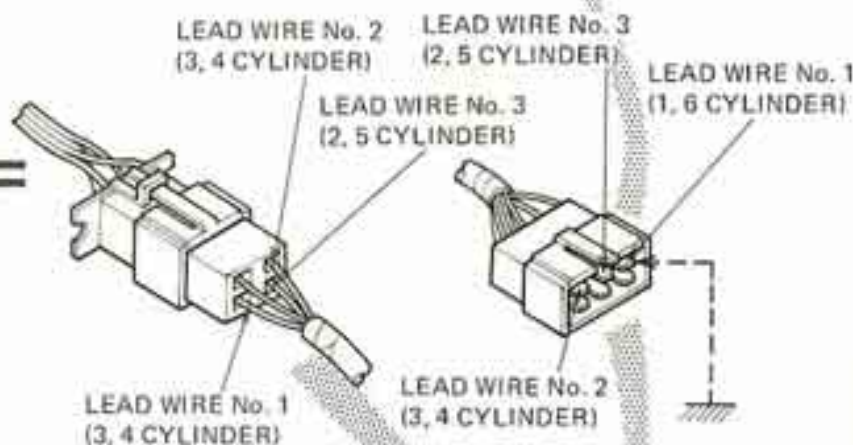
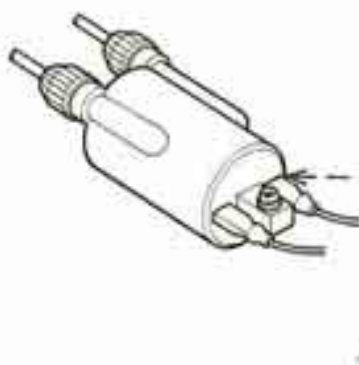
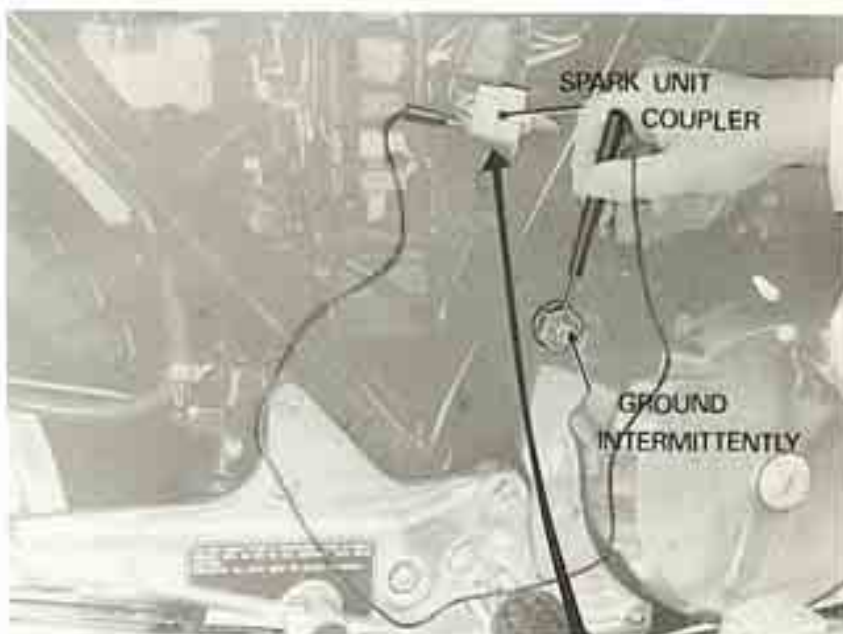

Ground each corresponding terminal of the 6-pole coupler intermittently (1,6, 2,5 and 3,4).

The transistor unit is normal if the voltage indicated by the voltmeter changes from 12V to 0V in each test.

### SPARK ADVANCER/ PULSER REMOVAL

For advancer/pulser removal, see Page 8-2.  
For advancer function test, see Page 3-6.

#### ADVANCER VISUAL INSPECTION

Check the mechanical advancer cam for sticking.

Lubricate the sliding surfaces, and check the spring for loss of tension and advancer pin for excessive wear if the advancer fails to return.

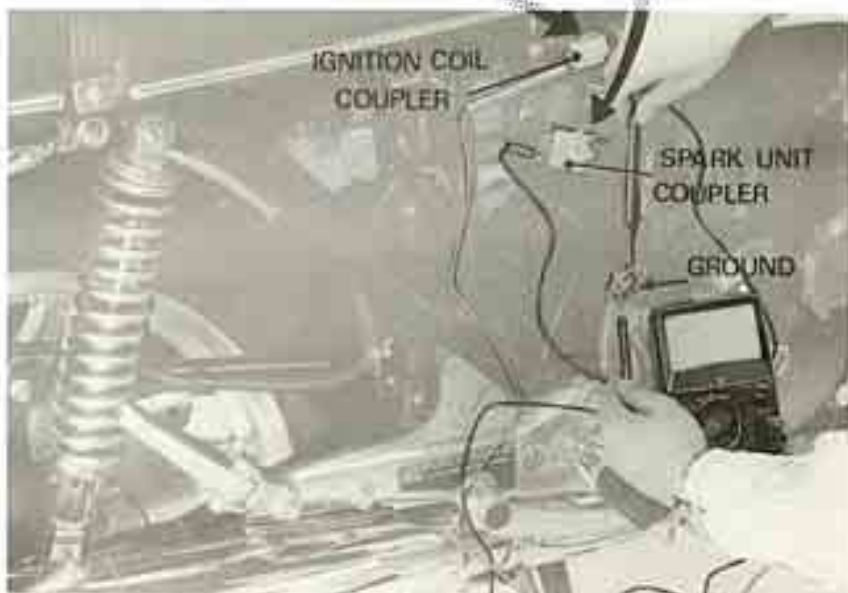



SERVICE INFORMATION	18-1
TROUBLESHOOTING	18-1
STARTER MOTOR	18-2
MAGNETIC SWITCH	18-6

## SERVICE INFORMATION

### WORKING PRACTICE

The starter motor can be removed with the engine in the frame.

### SPECIFICATION

Starter motor	STANDARD		SERVICE LIMIT
	Brush spring tension	560 g-680g (19.75-23.89 oz)	560 g (19.75 oz)
Brush length	12.0-13.0 mm (0.47-0.51 in)	7.5 mm (0.03 in)	

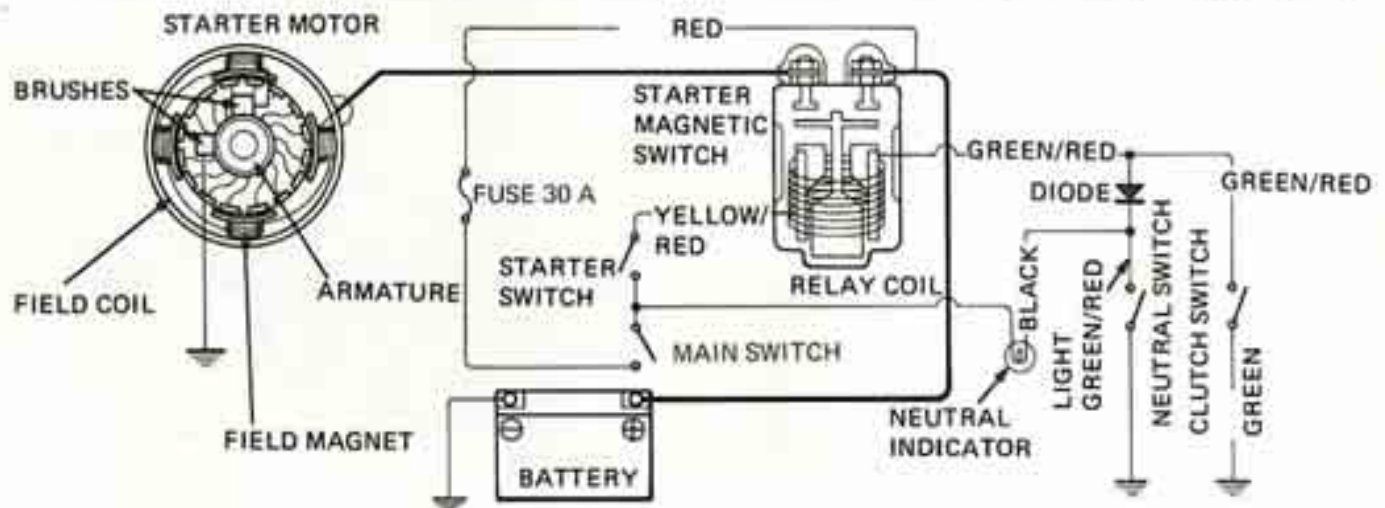

## TROUBLESHOOTING

### Starter Motor Will Not Turn:

- Battery discharged
- Faulty ignition switch
- Faulty start switch
- Faulty neutral switch
- Faulty starter magnetic switch
- Loosen or disconnected wire or cable
- Neutral diode open

### Starter Motor Turns Engine Slowly

- Low specific gravity
- Excessive resistance in circuit
- Binding in starter motor

### Starter Motor Turns, But Engine Does Not Turn:

- Faulty starter clutch
- Faulty starter motor gears
- Faulty starter motor or idle gear

### Starter Motor and Engine Turns, But Engine Does Not Start

- Faulty ignition system
- Engine problems





## STARTER MOTOR

### REMOVAL

**WARNING**

*With the ignition switch OFF, remove the negative cable at the battery before servicing the starter motor.*

Loosen the drive sprocket cover mounting bolts.

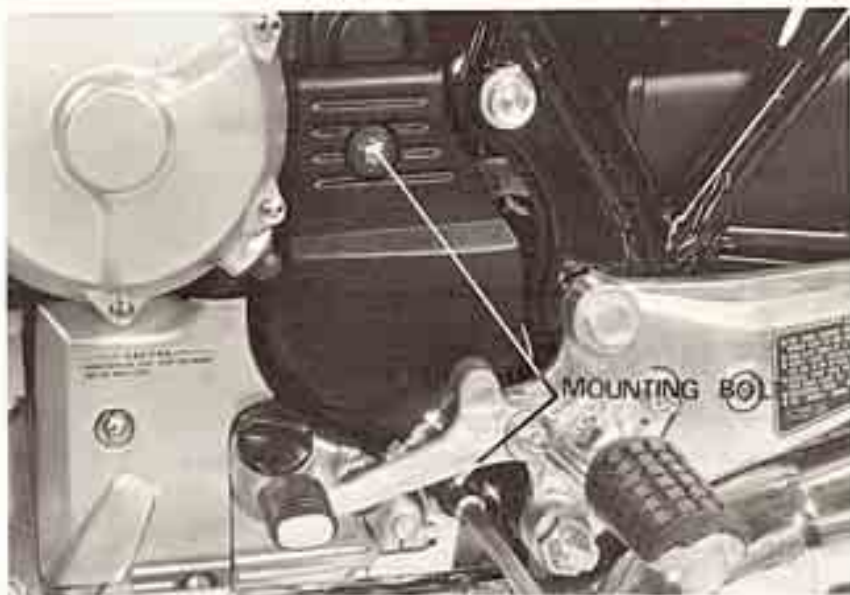

Remove the drive sprocket cover, and pull back and to the right.



Remove the starter motor ground cable and the drive sprocket cover packing.







Remove the right side cover and disconnect the starter cable at the magnetic switch. Remove the starter motor.

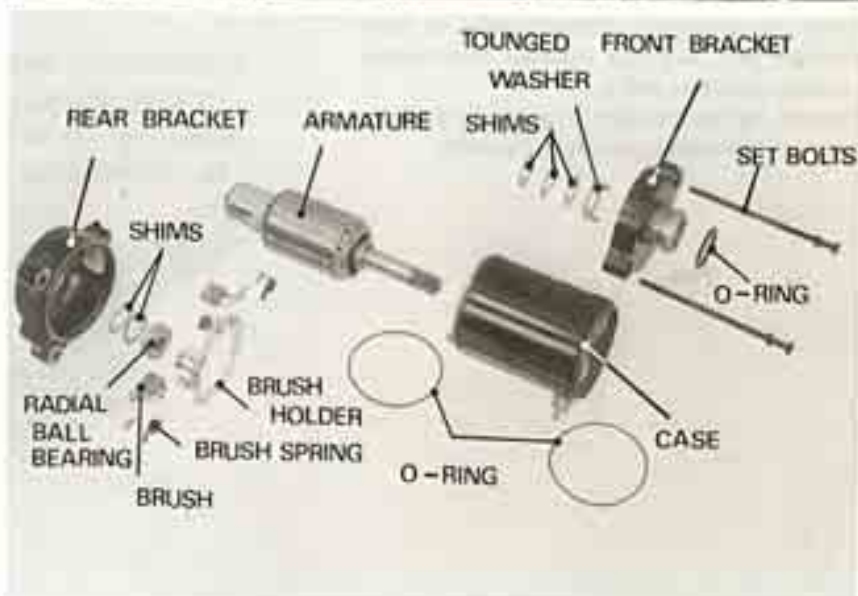
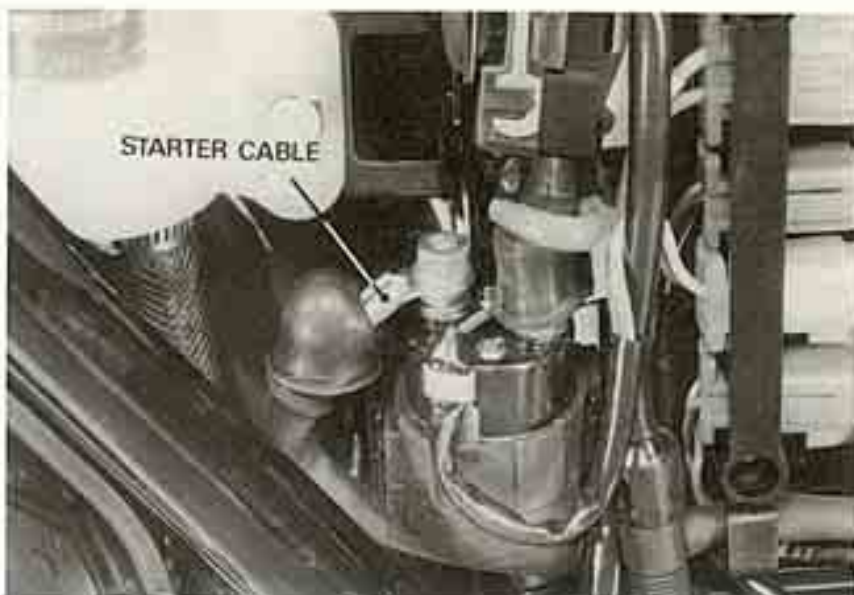

### BRUSH INSPECTION

Remove the starter motor case screws. Inspect the brushes and measure the brush length. Measure brush spring tension with a spring scale.

#### SERVICE LIMITS:

Brush length: 7.5 mm (0.30 in)  
Brush spring tension: 560 g

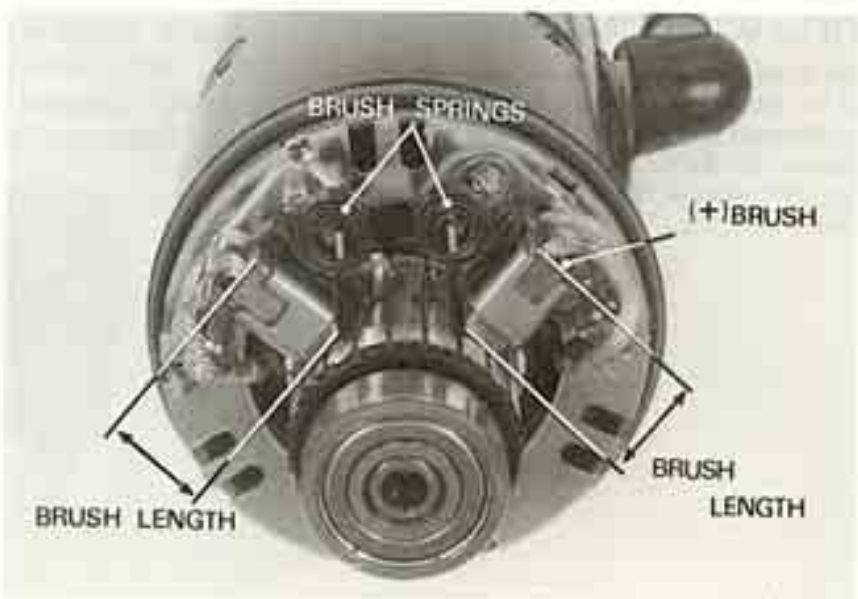



**ELECTRIC STARTER**

**COMMUTATOR INSPECTION**

Remove the starter motor case.

**NOTE**

Record the location and number of the thrust washers.

Inspect the commutator bars for discoloration. Bars discolored in pairs indicate grounded armature coils.

**NOTE**

Do not use emery or sand paper on the commutator.

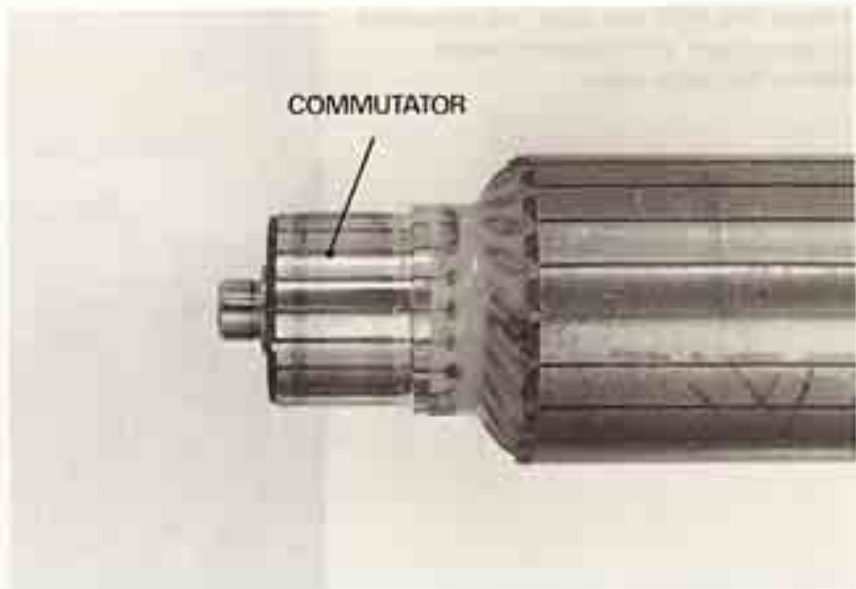

Check for continuity between pairs of commutator bars, and also between commutator bars and armature shaft. Replace the starter motor if armature coils are open, or shorted to the armature shaft.



**FIELD COIL INSPECTION**

Check for continuity from the cable terminal to the motor case and from the cable terminal to the brush wire. Replace the starter motor if the field coil is not continuous or if it is shorted to the motor case.





**ASSEMBLY/INSTALLATION**

Assemble the starter motor.  
Align the case notch with the brush holder pin.

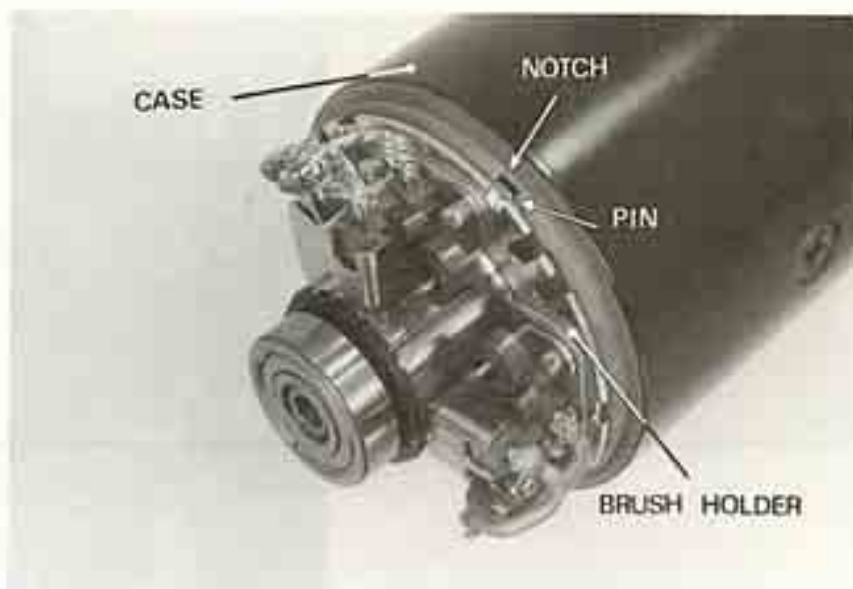

Install the rear bracket aligning its slot with the brush holder pin.

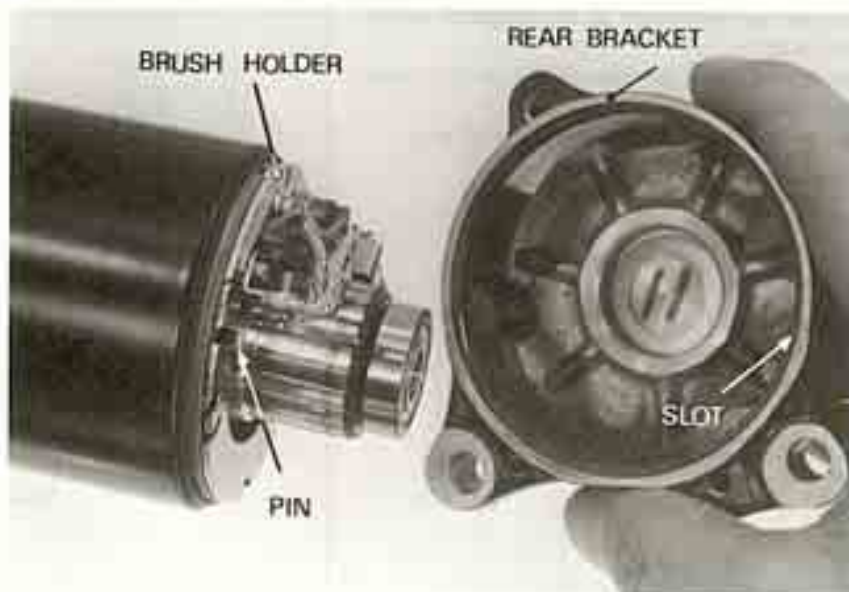





## MAGNETIC SWITCH

### INSPECTION

Depress the starter switch button with the ignition ON.

The coil is normal if the magnetic switch clicks.



Connect an ohmmeter to the magnetic switch terminals.

Connect a 12 V battery to the switch cable terminals.

The switch is normal if there is continuity.

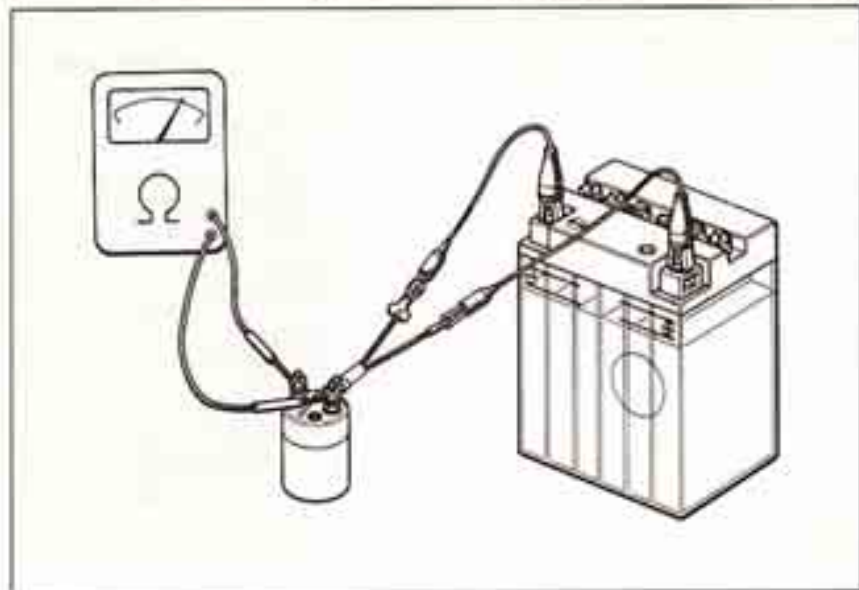



SERVICE INFORMATION	19-1	HANDLEBAR SWITCHES	19-3
OIL PRESSURE WARNING SWITCH	19-2	IGNITION SWITCH	19-4
BRAKE SWITCHES	19-2	CLUTCH SWITCH	19-4
NEUTRAL SWITCH	19-2		

## SERVICE INFORMATION

### WORKING PRACTICE

All electrical wires and connectors are color-coded. When two or more different colored wires are connected, a colored tube that matches the significant color appears on the other wire near the connector. Observe the color codes before disconnecting any wires.

All plastic plugs have locking tabs that must be released before disconnecting, and must be aligned when reconnecting.

The following color codes used are indicated throughout this section and on the wiring diagram.

<b>B</b> = Blue	<b>LG</b> = Light Green
<b>Bk</b> = Black	<b>O</b> = Orange
<b>Br</b> = Brown	<b>P</b> = Pink
<b>G</b> = Green	<b>R</b> = Red
<b>Gr</b> = Grey	<b>W</b> = White
<b>LB</b> = Light Blue	<b>Y</b> = Yellow

In order to isolate an electrical failure, check the continuity of the electrical path through the part. A continuity check can usually be made without removing the part from the motorcycle — by simply disconnecting the wires and connecting a continuity tester or volt-ohmmeter to the terminals or connections.

A continuity tester is useful when checking to find out whether or not there is an electrical connection between the two points. If the quality of the circuit is important, as when there is a specific coil resistance involved, or when checking for high resistance caused by corroded connections, an ohmmeter is needed.



## OIL PRESSURE WARNING SWITCH

Check for continuity while applying pressure to the switch.  
Replace the switch if necessary.

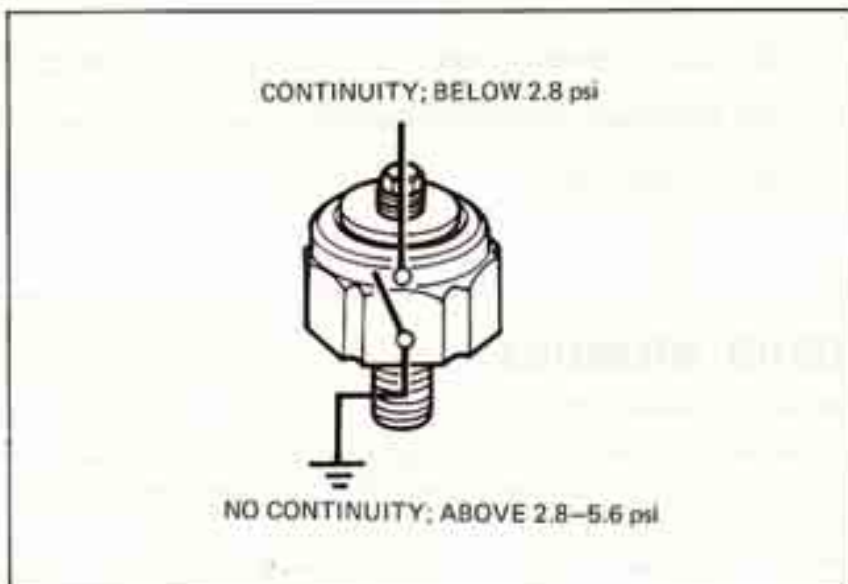

## BRAKE SWITCHES

Check the rear brakelight switch for continuity with the rear brake applied.

Check the front brakelight switch for continuity with the front brake applied.

Replace the switches if necessary.

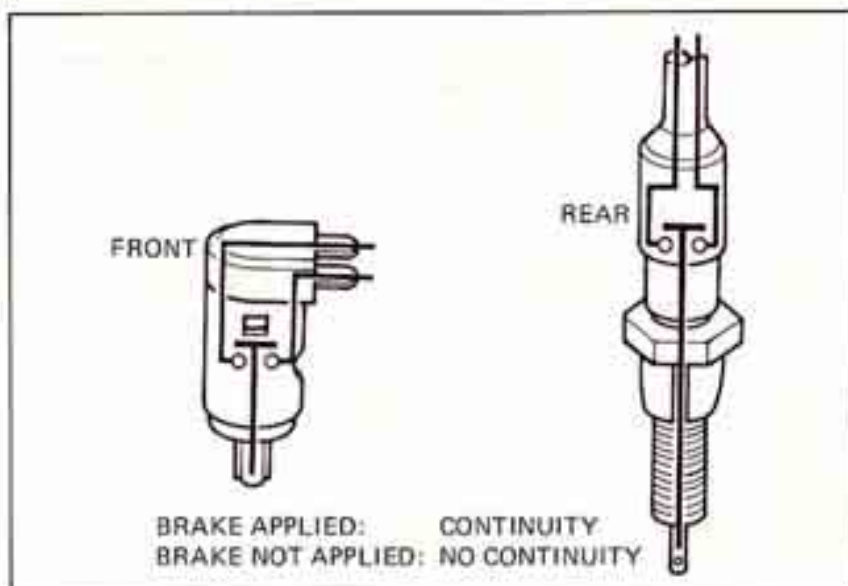

## NEUTRAL SWITCH

Check the switch for continuity between the switch terminal (wire removed) and ground with the transmission in neutral and with the transmission in any gear.

### NOTE

To replace the neutral switch, remove the left muffler and oil hose cover.

Replace the neutral switch if necessary.

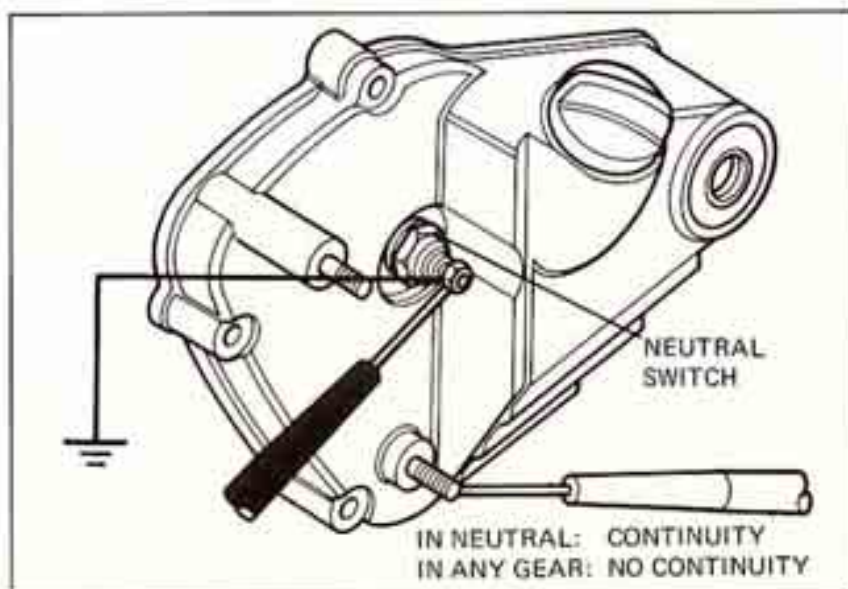





### HANDLEBAR SWITCHES

The handlebar cluster switches (lights, turn signals, horn, start and stop) must be replaced as assemblies.

Continuity tests for the components of the handlebar cluster switches follow:

Continuity should exist between the color coded wires on each chart.

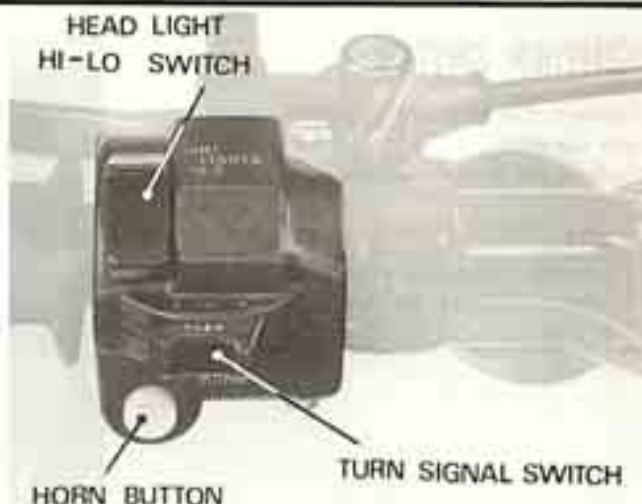

#### HEADLIGHT HI-LOW SWITCH

HI: B/W to B  
MIDDLE (N): B/W to W to B  
LO: B/W to W

Headlight Hi-Low Switch

	HL	HB	LB
Hi	○—○		
(N)	○—○—○		
Lo	○—○—○		
Code color	B/W	B	W

#### TURN SIGNAL SWITCH

LEFT: Gr to O, Br/W to LB/W  
OFF: Br/W to O/W to LB/W  
RIGHT: Gr to LB, Br/W to O/W

Turn Signal Switch

	TR	LT	RT	P	PL	PR
LEFT	○—○			○—○—○		
OFF				○—○—○		
RIGHT	○—○			○—○		
Code color	Gr	O	LB	Br/W	O/W	LB/W

#### HORN BUTTON

LG to G with button depressed  
No continuity with button released

Horn Button

	HO	E
Code color	LG	G

Starter Button

	BAT5	HL	BAT2	ST
FREE	○—○			
START			○—○	
Code color	Bk/R	B/W	Bk	Y/R

#### STARTER BUTTON

Bk/R to B/W with button released  
Bk to Y/R with button depressed

Engine Stop Switch

	BAT2	IG
OFF		
RUN	○—○	
OFF		
Code color	Bk	Bk/W

#### ENGINE STOP SWITCH

RUN: Bk to Bk/W  
OFF: No continuity





**SWITCHES**

**IGNITION SWITCH**

Remove the instrument cluster and disconnect the plug.  
Remove the ignition switch.

**NOTE**

Identify the wire colors at the connector. There are no colors on the switch.

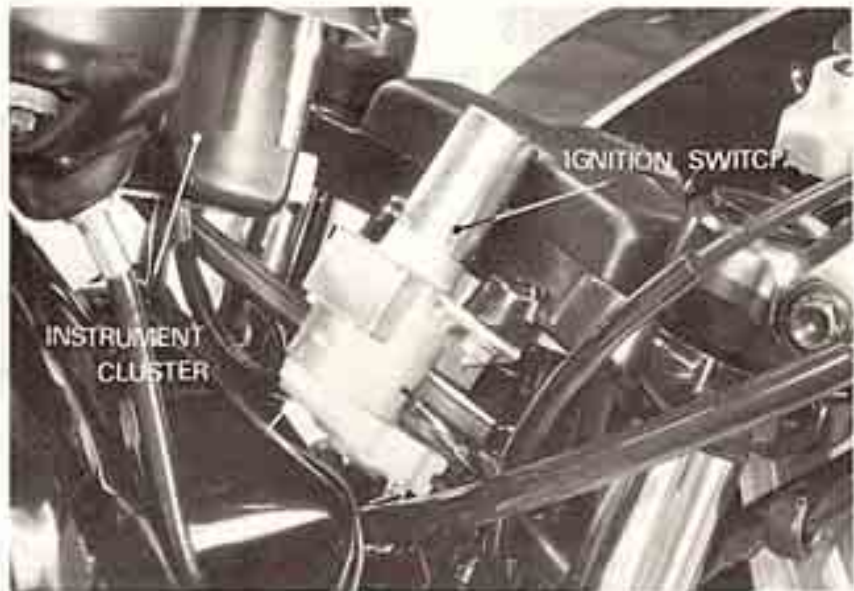

Check continuity of terminals on the ignition switch in each switch position.

**SWITCH POSITION**

- LOCK:** No continuity
- OFF:** No continuity
- ON:** BAT to IG, TL to TL
- PARK:** PA to BAT

Terminal Position	PA	BAT	IG	TL <sub>1</sub>	TL <sub>2</sub>
P	○—○				
ON		○—○	○—○	○—○	
OFF					
LOCK					

**IGNITION SWITCH**

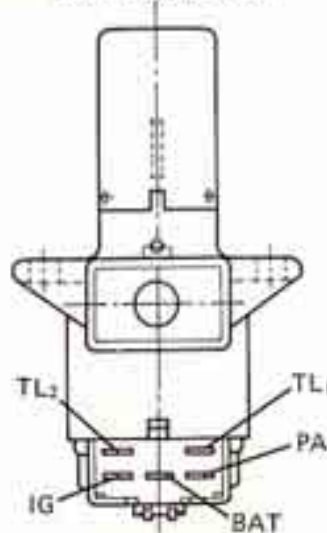

**CLUTCH SWITCH**



**CLUTCH APPLIED:** CONTINUITY  
**CLUTCH RELEASED:** NO CONTINUITY

**CLUTCH SWITCH**

Check continuity of the clutch lever (safety) switch with the clutch released and applied.  
Replace if necessary.

**REMOVAL**

Unplug the wires.  
Remove the clutch lever and cable.  
Remove the switch.

**NOTE**

The switch case has a small protrusion that must point toward the handlebar when installed.

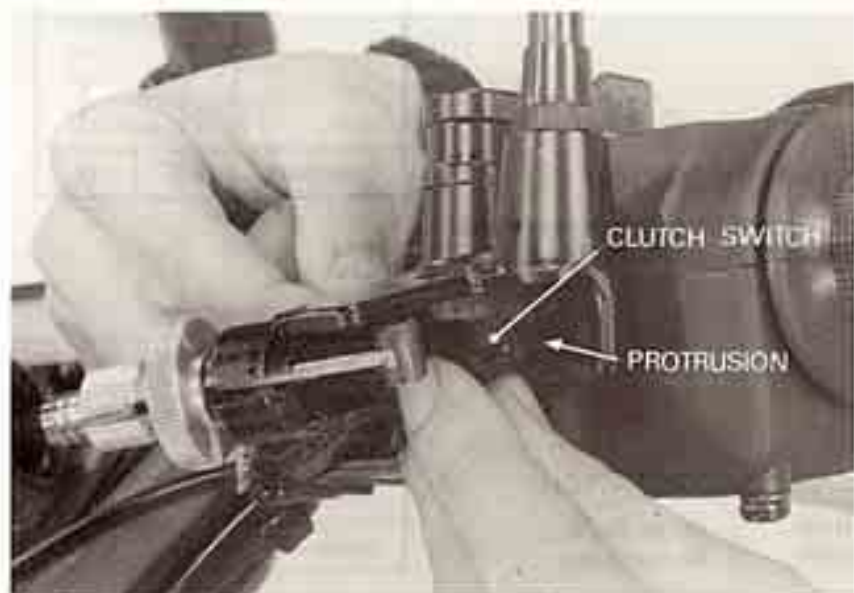





ENGINE CONSTRUCTION

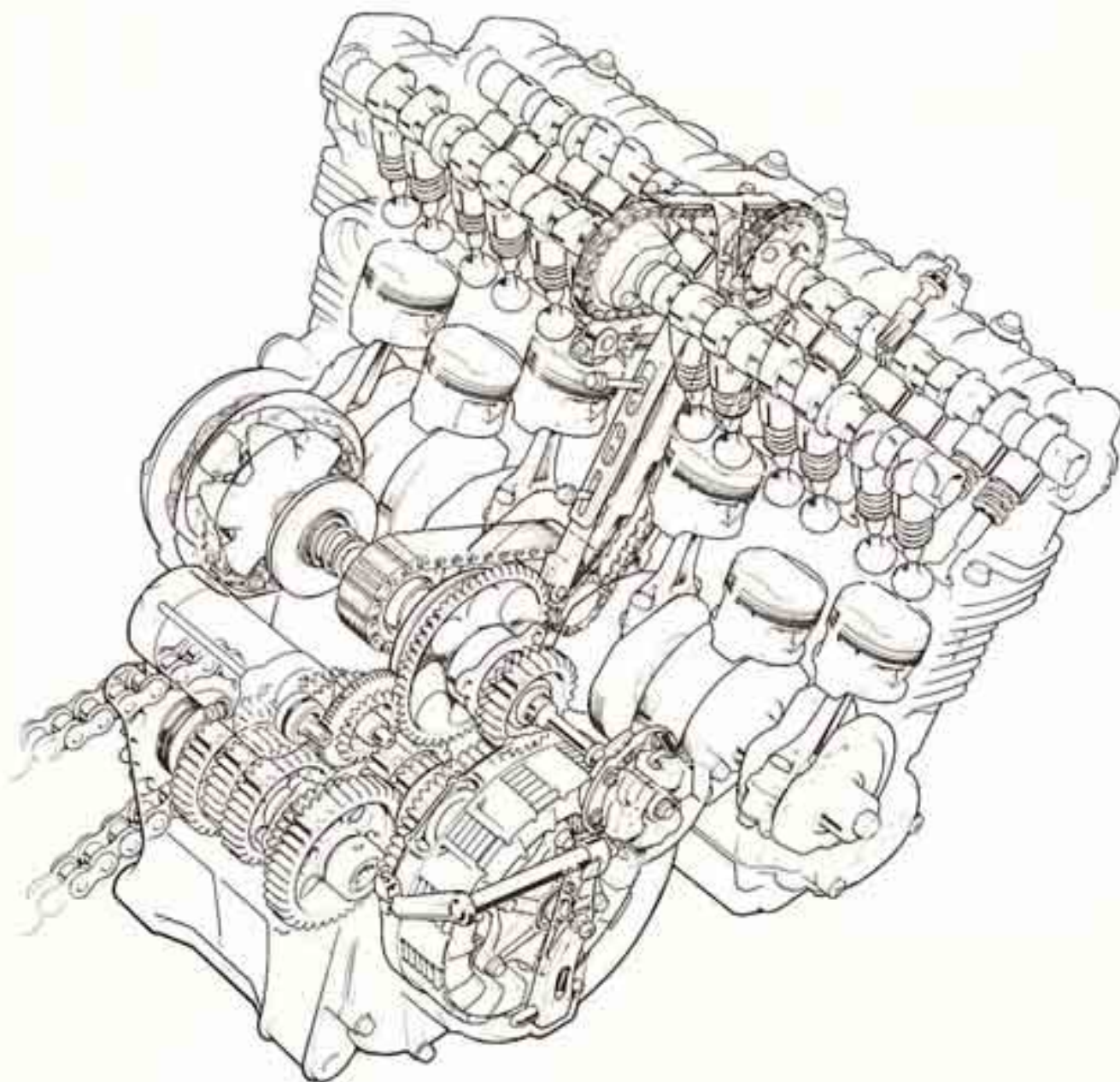





## DUAL CAM CHAINS

Dual cam chains drive the camshafts. Drive is transmitted from the crankshaft to the exhaust camshafts and from there to the intake camshafts. This eliminates a diagonal chain path through the rear of the engine, reducing the distance between the carburetors and cylinders.

The narrow air cleaner and canted carburetors eliminate interference with the rider's legs.

The cam chains are durable silent type.

Each chain has a guide. Chain tensioners are the slipper type.

## 24 VALVES, SEPARATED CAMSHAFTS

Each cylinder has two intake and two exhaust valves. The arrangement insures effective breathing at high speed without valve float. Four valves instead of two allow a large overall port area with a low reciprocating weight for each valve spring.

The camshafts are of a two-piece forging. The separated shafts provide rigidity with more even valve lift. The joint at the center compensates for any misalignment between the shafts.

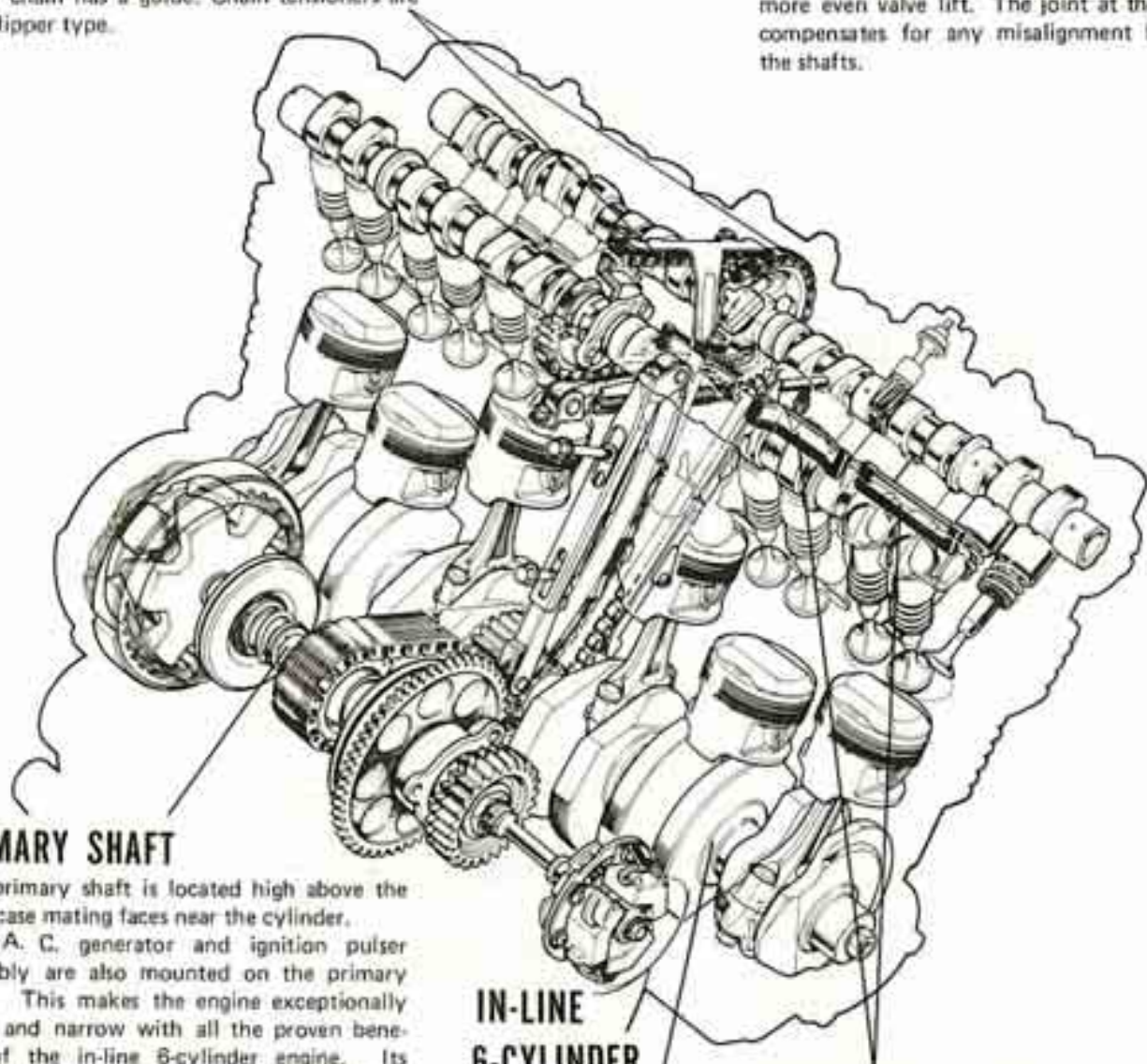

## PRIMARY SHAFT

The primary shaft is located high above the crankcase mating faces near the cylinder.

The A. C. generator and ignition pulser assembly are also mounted on the primary shaft. This makes the engine exceptionally short and narrow with all the proven benefits of the in-line 6-cylinder engine. Its physical size is equal to the standard in-line 4-cylinder motorcycles in its cc class.

## IN-LINE 6-CYLINDER ARRANGEMENT

The in-line ultra short 53.4 mm stroke 6-cylinder arrangement reduces the vehicle's height. It also reduces piston speed and minimizes wear.

## CAMSHAFT OIL POOL PLATES

The engine oil is collected in the camshaft troughs by oil pool plates for positive lubrication of the valve lifters and cams. The plates also contribute to quieter valve operation.



## VALVE MECHANISM

The valves are operated by the cams through the valve lifters. The shims can be removed and installed easily without removing the camshafts by pushing down on the lifters with a special tool.

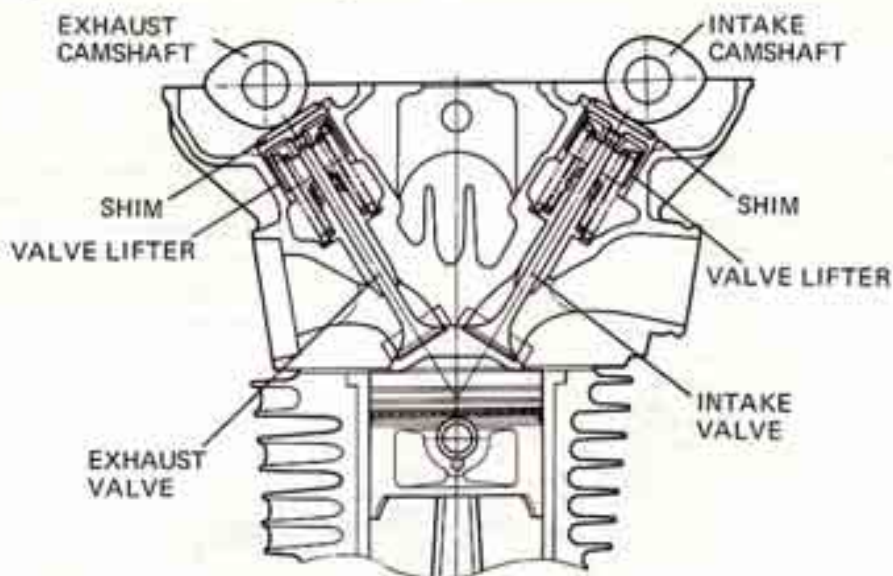

## A.C. GENERATOR COUPLING

Power from the primary shaft is transmitted to the generator through a frictional coupling. The coupling consists of two steel discs pressed against each other by a spring. Relative movement between the discs prevents excessive inertia from being transmitted directly from the generator to the primary chain when snapping.

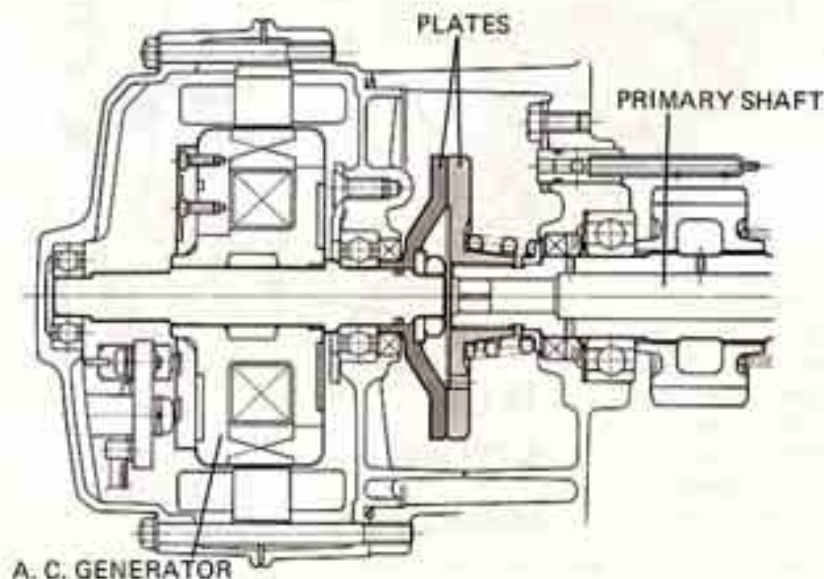





## OIL COOLER, OIL PUMP

The lubricating system uses a wet sump with the sump at the crankcase bottom. The oil is cooled by an oil cooler.

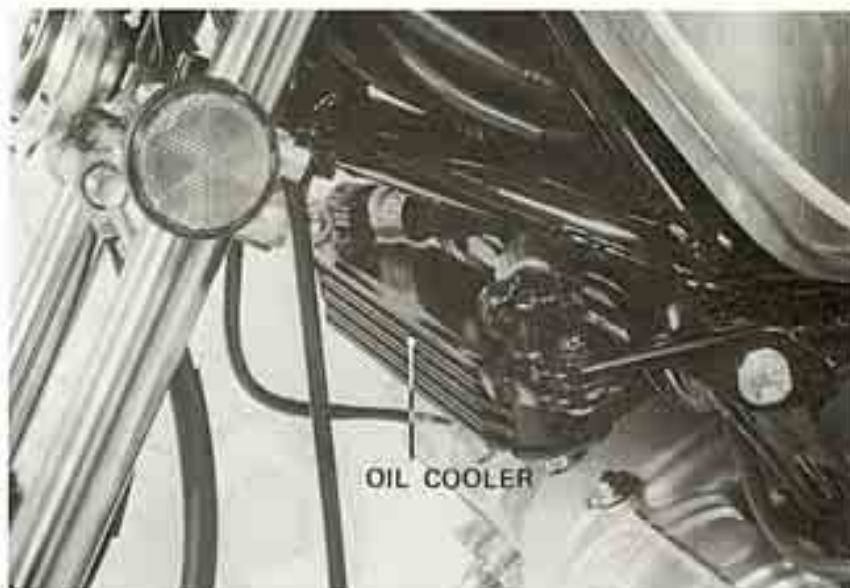

A tandem trochoid pump supplies oil to the bearings and other moving parts of the engine. Oil from the oil sump is forced by the main pump into the crankshaft and cylinder head.

The auxiliary pump feeds oil to the primary shaft and transmission. The oil cooler is in the auxiliary pump circuit and cools the oil drawn from the sump by the auxiliary pump. The oil damper in the primary chain receives oil from this pump circuit.

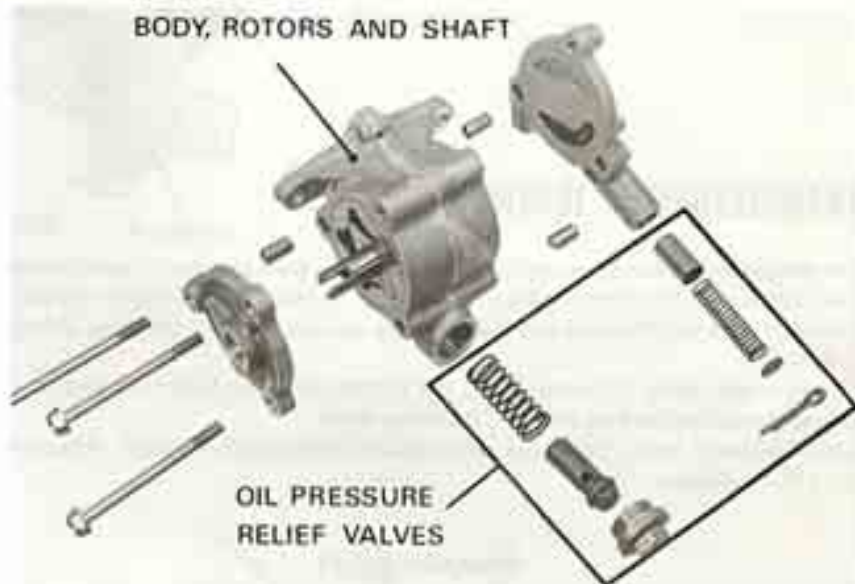

Oil from the sump must pass through a strainer before it enters the pumps.







## OIL DAMPER TYPE PRIMARY CHAIN TENSIONER

Primary chain tension is controlled by an oil dampened chain tensioner. It consists of a one-way check valve using a steel ball, a spring and a tension bar. The bar has an oil chamber with small orifices at its end. Oil in the chamber compensates for cavitation, assuring positive damper action at all times.

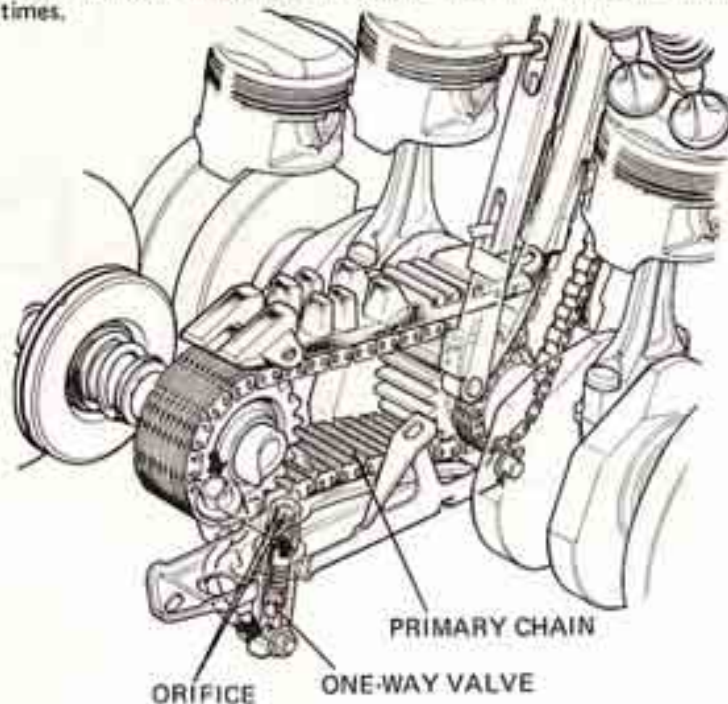

## TRANSISTORIZED IGNITION

The engine uses a transistorized ignition. A pulser generator and transistorized spark unit supply current to the primary circuit. The system is free from problems that occur in mechanical breaker systems. It produces stable secondary energy and eliminates periodic adjustments and maintenance services. There are three independent systems; one for 1 & 6, 2 & 5, and 3 & 4 cylinders.

The generator rotor is connected to the primary shaft so they turn as a unit as the shaft rotates. Three generating coils are spaced evenly on the base plate, 120 degrees apart.

When the rotor turns, pulses are generated as it passes over the coils. Adjusting timing for 1 & 6 cylinders automatically adjusts the other cylinders.

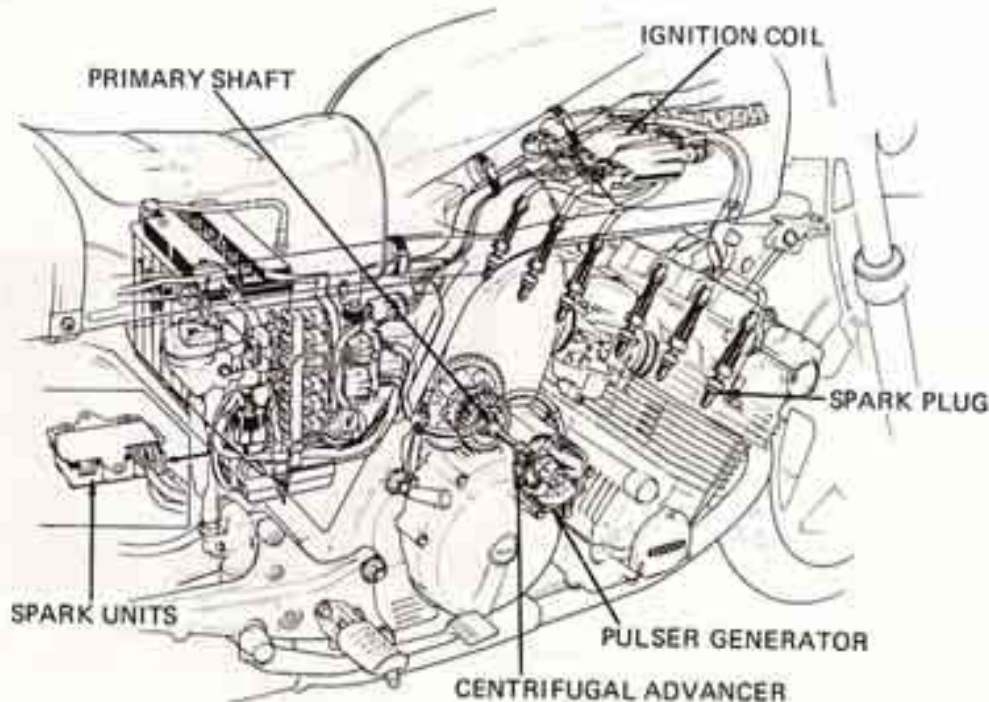



# 21. TROUBLESHOOTING

## ENGINE DOES NOT START OR IS HARD TO START

1. Check fuel flow to carburetor

REACHING CARBURETOR



2. Perform spark test

GOOD SPARK



3. TEST CYLINDER COMPRESSION

COMPRESSION NORMAL



4. Start by following normal procedure

ENGINE DOES NOT FIRE



5. Remove and inspect spark plug

NOT REACHING CARBURETOR



POSSIBLE CAUSE

- (1) Fuel tank empty
- (2) Clogged fuel tube or fuel filter
- (3) Sticking float valve
- (4) Clogged fuel tank cap breather hole

WEAK OR NO SPARK



- (1) Faulty spark plugs
- (2) Fouled spark plugs
- (3) Faulty spark unit
- (4) Broken or shorted high tension wires
- (5) Faulty A.C. generator
- (6) Broken or shorted ignition coil
- (7) Faulty ignition switch
- (8) Faulty pulser generator

LOW COMPRESSION



- (1) Low battery charge
- (2) Improper valve clearance
- (3) Valve stuck open
- (4) Worn cylinder and piston rings
- (5) Damaged cylinder head gasket
- (6) Seized valve
- (7) Improper valve timing

ENGINE FIRES BUT STOPS



- (1) Improper choke operation
- (2) Carburetor incorrectly adjusted
- (3) Manifold leaking
- (4) Improper ignition timing (Spark unit or pulser generator)
- (5) Incorrect fast idle
- (6) Fuel contaminated

WET PLUG



- (1) Carburetor flooded
- (2) Choke closed
- (3) Throttle valve open
- (4) Air cleaner dirty



## TROUBLESHOOTING

### ENGINE LACKS POWER

1. Raise wheels off ground and spin by hand

WHEEL SPINS FREELY

2. Check tire pressure

PRESSURE NORMAL

3. Accelerate rapid from low to second

ENGINE SPEED LOWERED WHEN CLUTCH IS RELEASED

4. Accelerate lightly

ENGINE SPEED INCREASES

5. Check ignition timing

CORRECT

6. Check valve clearance

CORRECT

7. Test cylinder compression

NORMAL

8. Check carburetor for clogging

NOT CLOGGED

9. Remove spark plug

NOT FOULED OR DISCOLORED

10. Check oil level and condition

CORRECT

11. Remove cylinder head cover and inspect lubrication

VALVE TRAIN LUBRICATED PROPERLY

12. Check for engine overheating

NOT OVERHEATING

13. Accelerate or run at high speed

ENGINE DOES NOT KNOCK

### POSSIBLE CAUSE

WHEELS DO NOT SPIN FREELY

- (1) Brake dragging
- (2) Worn or damaged wheel bearing
- (3) Wheel bearing needs lubrication
- (4) Drive chain too tight

PRESSURE LOW

- (1) Punctured tire
- (2) Faulty tire valve

ENGINE SPEED CHANGED WHEN CLUTCH IS RELEASED

- (1) Clutch slipping
- (2) Worn clutch disc/plate
- (3) Warped clutch disc/plate

ENGINE SPEED NOT INCREASED

- (1) Carburetor choke closed
- (2) Clogged air cleaner
- (3) Restricted fuel flow
- (4) Clogged fuel tank breather tube
- (5) Clogged muffler

INCORRECT

- (1) Faulty spark unit
- (2) Faulty pulser generator
- (3) Faulty ignition advancer

INCORRECT

- (1) Improper valve adjustment
- (2) Worn valve seat

TOO LOW

- (1) Valve stuck open
- (2) Worn cylinder and piston rings
- (3) Leaking head gasket
- (4) Improper valve timing

CLOGGED

- (1) Carburetor not serviced frequently enough

FOULED OR DISCOLORED

- (1) Plugs not serviced frequently enough
- (2) Spark plug with incorrect heat range

INCORRECT

- (1) Oil level too high
- (2) Oil level too low
- (3) Contaminated oil

VALVE TRAIN NOT LUBRICATED PROPERLY

- (1) Clogged oil passage
- (2) Clogged oil control orifice

OVERHEATING

- (1) Excessive carbon build-up in combustion chamber
- (2) Use of poor quality fuel
- (3) Clutch slipping
- (4) Fuel-air mixture too lean

ENGINE KNOCKS

- (1) Worn piston and cylinder
- (2) Fuel-air mixture too lean
- (3) Wrong type of fuel
- (4) Excessive carbon build-up in combustion chamber
- (5) Ignition timing too advanced (Faulty spark unit or advancer)





### POOR PERFORMANCE AT LOW AND IDLE SPEEDS

<p>1. Check ignition timing and valve clearance</p> <p>CORRECT</p> <p>↓</p> <p>2. Check carburetor pilot screw adjustment</p> <p>CORRECT</p> <p>↓</p> <p>3. Check for leaking manifold</p> <p>NO LEAK</p> <p>↓</p> <p>4. Perform spark test</p> <p>GOOD SPARK</p>	<p>INCORRECT →</p> <p>INCORRECT → See Fuel System Section</p> <p>LEAKING →</p> <p>WEAK OR INTERMITTENT SPARK →</p>	<p><b>POSSIBLE CAUSE</b></p> <p>(1) Improper valve clearance (2) Improper ignition timing (Faulty spark unit or spark advancer)</p> <p>(1) Deteriorated insulator O-ring (2) Loose carburetor</p> <p>(1) Faulty, carbon or wet fouled spark plug (2) Faulty spark unit (3) A.C. generator faulty (4) Faulty ignition coil (5) Faulty spark advancer</p>
---	--	---

### POOR PERFORMANCE AT HIGH SPEED

<p>1. Check ignition timing and valve clearance</p> <p>CORRECT</p> <p>↓</p> <p>2. Disconnect fuel tube at carburetor</p> <p>FUEL FLOWS FREELY</p> <p>↓</p> <p>3. Remove carburetor and check for clogged jet</p> <p>NO CLOG</p> <p>↓</p> <p>4. Check valve timing</p> <p>CORRECT</p> <p>↓</p> <p>5. Check valve spring tension</p> <p>NOT WEAKENED</p>	<p>INCORRECT →</p> <p>FUEL FLOW RESTRICTED →</p> <p>CLOGGED →</p> <p>INCORRECT →</p> <p>WEAK →</p>	<p>(1) Improper valve clearance (2) Faulty spark unit (3) Faulty pulser generator (4) Faulty spark advancer</p> <p>(1) Lack of fuel in tank (2) Clogged fuel line (3) Clogged fuel tank breather hole (4) Clogged fuel cock</p> <p>(1) Clean</p> <p>(1) Cam sprocket not installed properly</p> <p>(1) Faulty spring</p>
--	--	--

### POOR HANDLING → Check tire pressure

<p>1. If steering is heavy →</p> <p>2. If either wheel is wobbling →</p> <p>3. If the motorcycle pulls to one side →</p>	<p>(1) Steering top thread nut too tight (2) Damaged steering head bearings</p> <p>(2) Excessive wheel bearing play (2) Distorted rim (3) Improperly installed wheel hub (4) Swing arm pivot bushing excessively worn (5) Distorted frame (6) Improper drive chain tension or adjustment</p> <p>(1) Improperly adjusted shock absorber (2) Front and rear wheels not aligned (3) Bent front fork (4) Bent swing arm</p>
--	---



## INTRODUCTION

This Addendum contains information for the 1980 CBX. Refer to the base shop manual for service information not included in this addendum.

ALL INFORMATION, ILLUSTRATIONS, DIRECTIONS AND SPECIFICATIONS INCLUDED IN THIS PUBLICATION ARE BASED ON THE LATEST PRODUCT INFORMATION AVAILABLE AT THE TIME OF APPROVAL FOR PRINTING. HONDA MOTOR CO., LTD. RESERVES THE RIGHT TO MAKE CHANGES AT ANY TIME WITHOUT NOTICE AND WITHOUT INCURRING ANY OBLIGATION WHATSOEVER.

NO PART OF THIS PUBLICATION MAY BE REPRODUCED WITHOUT WRITTEN PERMISSION.

HONDA MOTOR CO., LTD.  
Service Publications Office

## CONTENTS

- I. SPECIFICATIONS ..... 22- 2
- II. TORQUE VALUES ..... 22- 4
- III. SPECIAL TOOLS/COMMON TOOLS 22- 5
- IV. CABLE AND HARNESS ROUTING 22- 7
- V. MAINTENANCE SCHEDULE ..... 22- 9
- VI. INSPECTION AND ADJUSTMENT . 22-10
- VII. FUEL SYSTEM ..... 22-14
- VIII. CYLINDER HEAD/VALVES ..... 22-19
- IX. FRONT WHEEL/SUSPENSION ..... 22-20
- X. REAR WHEEL/SUSPENSION ..... 22-26
- XI. TROUBLE SHOOTING ..... 22-34
- XII. TECHNICAL FEATURES ..... 22-35
- XIII. WIRING DIAGRAM ..... 22-35

**I. SPECIFICATIONS**

ITEM			
DIMENSIONS	Overall length	2,220 mm (87.4 in)	
	Overall width	885 mm (34.8 in)	
	Overall height	1,175 mm (46.3 in)	
	Wheelbase	1,485 mm (58.5 in)	
	Seat height	810 mm (31.9 in)	
	Foot peg height	330 mm (13.0 in)	
	Ground clearance	150 mm (5.9 in)	
	Dry weight	252 kg (555.6 lb)	
FRAME	Type	Diamond	
	Front suspension, travel	Telescopic air forks 160 mm (6.3 in)	
	Rear suspension, travel	Swing arm 100 mm (3.9 in)	
	Front tire size	3.50V19 (4PR)	
	Rear tire size	4.25V18 (4PR)	
	Cold tire pressures	Up to 90 kg (200 lbs) load	Front 2.25 kg/cm <sup>2</sup> (32 psi) Rear 2.25 kg/cm <sup>2</sup> (32 psi)
		Up to vehicle capacity load	Front 2.25 kg/cm <sup>2</sup> (32 psi) Rear 2.8 kg/cm <sup>2</sup> (40 psi)
	F. brake, lining swept area	Double disc brake	
	R. brake lining, swept area	Single disc brake	
	Fuel capacity	20.0 liters (5.28 US gal)	
Fuel reserve capacity	5.0 liters (1.32 US gal)		
Caster angle	62°30'		
Trail	120 mm (4.7 in)		
Front fork oil capacity	240 cc (8.2 ozs)		
Front fork air pressure	0.7 ± 0.2 kg/cm <sup>2</sup> (10 ± 3 psi)		
ENGINE	Type	Air cooled 4-stroke	
	Cylinder arrangement	Vertical parallel six	
	Bore and stroke	64.5 x 53.4 mm (2.54 x 2.10 in)	
	Displacement	1047 cc (63.89 cu in)	
	Compression ratio	9.3 : 1	
	Valve train	Chain driven DOHC 4 valve/cylinder	
	Maximum horsepower	98 BHP/9,000 rpm	
	Maximum torque	8.5 kg-m (60.8 ft-lb)/8,000 rpm	
	Oil capacity	5.5 liters (5.8 US qt) after disassembly 4.0 liters (4.2 US qt) after draining	
	Lubrication system	Wet sump dual pump with oil cooler	
	Air filtration	Oiled polyurethane foam	
	Cylinder compression	12.0 ± 1.0 kg/cm <sup>2</sup> (170 ± 14 psi)	
	Intake valve	Opens 5° (BTDC) at 1 mm lift, 59° (BTDC) at 0 lift Closes 40° (ABDC) at 1 mm lift, 115° (ABDC) at 0 lift	
	Exhaust valve	Opens 45° (BBDC) at 1 mm lift, 100° (BBDC) at 0 lift Closes 0° (ATDC) at 1 mm lift, 67° (ATDC) at 0 lift	
	Valve clearance (Cold)	IN: } 0.06–0.13 mm (0.002–0.005 in) EX: }	
	Engine weight	106 kg (233.7 lb)	
	Idle speed	900 ± 100 rpm	
CARBURETION	Carburetor type	VB 28 mm (1.1 in) venturi bore	
	Identification number	VB62A	
	Pilot screw	Refer to page 22–18	
	Float level	15.5 mm (0.61 in)	





ITEM																				
<b>DRIVE TRAIN</b>	Clutch Transmission Primary reduction Gear ratio I Gear ratio II Gear ratio III Gear ratio IV Gear ratio V Final reduction Gear shift pattern	Wet, multi-plate 5-speed constant-mesh 2.269 2.438 1.750 1.391 1.200 1.037 2.333 (18/42) Left foot operated return system 1-N-2-3-4-5																		
<b>ELECTRICAL</b>	Ignition Ignition timing "F" mark Full advance Starting system Generator Battery capacity Spark plug ( ): Canada Model  Spark plug gap	Transistorized 10° BTDC static 41° BTDC at 8,000 rpm Starting motor only Three phase A.C. generator 350 W/5,000 rpm 12V - 18AH <table border="1" data-bbox="922 856 1511 1087"> <thead> <tr> <th colspan="2">For cold climate below 5°C, 41°F</th> <th colspan="2">Standard</th> <th colspan="2">For extended high speed riding</th> </tr> <tr> <th>ND</th> <th>NGK</th> <th>ND</th> <th>NGK</th> <th>ND</th> <th>NGK</th> </tr> </thead> <tbody> <tr> <td>X22ES-U (X22ER -U)</td> <td>D7EA (DR7ES)</td> <td>X24ES-U (X24ESR -U)</td> <td>D8EA (DR8ES -L)</td> <td>X27ES-U (X27ESR -U)</td> <td>D9EA (DR9ES)</td> </tr> </tbody> </table> 0.6-0.7 mm (0.024-0.028 in)	For cold climate below 5°C, 41°F		Standard		For extended high speed riding		ND	NGK	ND	NGK	ND	NGK	X22ES-U (X22ER -U)	D7EA (DR7ES)	X24ES-U (X24ESR -U)	D8EA (DR8ES -L)	X27ES-U (X27ESR -U)	D9EA (DR9ES)
For cold climate below 5°C, 41°F		Standard		For extended high speed riding																
ND	NGK	ND	NGK	ND	NGK															
X22ES-U (X22ER -U)	D7EA (DR7ES)	X24ES-U (X24ESR -U)	D8EA (DR8ES -L)	X27ES-U (X27ESR -U)	D9EA (DR9ES)															
<b>LIGHTS</b>	Headlight (low/high beam) Tail/stoplight Turn signal light (front/rear) Speedometer light Tachometer light Neutral indicator Turn signal indicator High beam indicator Running light	60/55W H4 BULB (Philips 12342/99, or equivalent) 3/32 cp SAE NO. 1157 32/32 cp SAE NO. F. 1034, R. 1073 2 cp SAE NO. 57 2 cp SAE NO. 57 2 cp SAE NO. 57 2 cp SAE NO. 57 2 cp SAE NO. 57 2 cp SAE NO. 57 3 cp SAE NO. 1034																		



## II. TORQUE VALUES

### • ENGINE

Item	Q'ty	Thread Dia (mm)	Torque kg-m (ft-lb)	Remarks
Cylinder head cover	8	6	0.8-1.2 ( 6- 9)	Apply molybdenum disulfide base grease to threads and underside of bolts.  Apply THREE-BOND
Cam holder	32	6	1.2-1.6 ( 9-12)	
Cylinder head	8	10	3.3-3.5 (24-25)	
Cylinder head	10	8	1.9-2.1 (14-15)	
Cam sprocket	4	7	1.4-1.8 (10-13)	
Spark plug	6		1.2-1.6 ( 9-12)	
Crankcase		8	2.3-2.7 (17-20)	
A.C. generator	1	14	3.6-4.4 (26-32)	
Primary shaft	1	22	4.0-5.0 (29-36)	
Mainshaft	1	25	4.5-5.5 (33-40)	
Drive sprocket	1	10	5.0-5.4 (36-39)	
Connecting rod nut	12	8	3.0-3.4 (22-25)	
Oil filter center bolt	1	20	2.7-3.3 (20-24)	
Oil pressure switch	1		1.5-2.0 (11-14)	
Neutral switch	1	10	1.1-1.5 ( 8-11)	
Oil drain bolt	1	12	2.8-3.2 (20-23)	
Oil pipe	1	8	1.8-2.2 (13-16)	
Oil pipe	1	10	2.0-2.4 (14-17)	

### • CHASSIS

Item	Q'ty	Thread Dia (mm)	Torque kg-m (ft-lb)	Remarks
Steering stem nut	1	24	8.0-12.0 (58-87)	UBS  UBS
Steering handlebar	2	8	2.8-3.2 (20-23)	
Front fork top bridge	2	7	0.9-1.3 ( 7- 9)	
Front fork bolt	2	31	1.5-3.0 (11-22)	
Front axle nut	1	12	5.5-6.5 (40-47)	
Front/rear brake disc	10	8	2.7-3.3 (20-24)	
Brake hose bolt	5	10	2.5-3.5 (18-25)	
Rear axle	1	18	8.0-10.0 (58-72)	
Final driven sprocket	5	12	8.0-10.0 (58-72)	
Swing arm pivot nut	1	14	6.0-7.0 (43-51)	
Seat strap	2	6	0.8-0.95 ( 6- 7)	
Engine hanger nut	3	14	9.0-10.0 (65-72)	
Air cleaner inlet duct	2	5	0.3-0.6 ( 2- 4)	
Steering Stem adjusting nut	1	26	1.1-1.3 ( 8- 9)	

Fasteners not listed should be tightened to the standard torque values below.

### STANDARD TORQUE VALUES

Type	Torque kg-m (ft-lb)	Type	Torque kg-m (ft-lb)
5 mm bolt, nut	0.45-0.6 (3.5-4.5)	5 mm screw	0.35-0.5 (2.5-3.6)
6 mm bolt, nut	0.8-1.2 (6-9)	6 mm screw	0.7-1.1 (5-8)
8 mm bolt, nut	1.8-2.5 (13-18)	6 mm flange bolt, nut	1.0-1.4 (7-10)
10 mm bolt, nut	3.0-4.0 (22-29)	8 mm flange bolt, nut	2.4-3.0 (17-22)
12 mm bolt, nut	5.0-6.0 (36-43)	10 mm flange bolt, nut	3.0-4.0 (22-29)

**III. SPECIAL TOOLS/COMMON TOOLS**

## • SPECIAL TOOLS (Newly provided for '80 CBX)

Tool Name	Part No.	Q'ty	Ref. page
Lock nut wrench	07908-4690001	1	22-34
Retainer wrench	07910-4690100	1	22-30
Bearing driver (needle bearing)	07946-4690100	1	22-32
Bearing driver (angular bearing)	07946-4690200	1	22-32
Dust seal driver	07948-4690100	1	22-32

## • SPECIAL TOOLS (Other models)

Tool Name	Part No.	Q'ty	Ref. page
Vacuum gauge set	07504-0020000	1	3-7
	(H/C No. 47978)	1	
Oil pressure gauge	07506-3000000	1	2-3
Snap ring pliers	07914-3230001	1	15-8, 15-15
Steering stem socket	07916-3710100	1	13-27
6 mm hollow set wrench	07917-3230000	1	13-20, 13-23
Race bearing remover	07946-3710500	1	13-26
Steering stem driver	07946-3710600	1	13-26
Bearing driver attachment	07946-3710700	1	13-27, 22-30
Piston base	07958-2500000	1	7-8
Valve guide reamer (5.5 mm)	07984-2000000	1	6-14, 6-16
Oil pressure gauge attachment	07510-4220100	1	2-3
Carburetor throttle wrench	07908-4220100	1	3-8, 4-12
Carburetor pilot screw wrench	07908-4220200 or	1	4-26
	07908-4220201		
Lock nut wrench	07916-4220000	1	8-4, 8-11
Primary gear holder	07924-4220000	1	8-7, 8-8
Piston ring compressor	07954-4220000	1	7-8
Valve lifter holder	07964-4220001	1	3-6
Degree wheel	07974-4220000 or	1	3-11
	07974-4220002		
Valve hole protector	07999-4220000	1	6-12, 6-18





**• COMMON TOOL**

Tool Name	Part No.	Q'ty	Alternate Tools (Common tool → Special tool)	Ref. Page
Float level gauge	07401-0010000	1		4-9
Pin spanner	07702-0010000	1		14-4, 14-7
Retainer wrench (A)	07710-0010100	1	07910-2630000&07910-3600000	14-4, 14-7
Retainer wrench (B)	07710-0010300	1	Bearing retainer wrench 07910-3230101	13-15, 13-17
Retainer wrench body	07710-0010400			13-15, 13-17, 14-4, 14-7
Lock nut wrench socket (26 x 30 mm)	07716-0020202	1		13-25, 13-28
Extension bar	07716-0020500	1	Commercially available	13-25, 13-28
Universal holder	07725-0010101	1	Flywheel holder 07923-0400000	8-3
Valve guide remover (5.5 mm)	07742-0010100	1	Valve guide driver 07942-3290100	6-15, 6-16
Bearing driver outer (32 x 35)	07746-0010100	1	Bearing driver 07945-4150200	16-7
Bearing driver outer (37 x 40)	07746-0010200	1	Bearing driver 07946-2860200	12-15, 16-7
Bearing driver outer (42 x 47)	07746-0010300	1	Bearing driver 07946-9350200	13-17
Bearing driver outer (52 x 55)	07746-0010400	1	Bearing driver 07946-9370100	12-16, 14-6
Bearing driver outer (62 x 68)	07746-0010500	1	Bearing driver 07946-3710200	14-6
Bearing driver handle (C)	07746-0030100	1	Bearing driver 07946-3600000	11-13, 12-16
Bearing driver inner (25 mm)	07746-0030200	1		12-16
Bearing driver inner (30 mm)	07746-0030300	1		11-13
Bearing driver pilot (15 mm)	07746-0040300	1		13-17
Bearing driver pilot (20 mm)	07746-0040500	1		14-6
Bearing driver pilot (25 mm)	07746-0040600	1		12-15, 12-16, 14-6
Front fork oil seal driver body	07747-0010100	1	Fork seal driver 07947-3710100	13-22
Front fork oil seal attachment (E)	07747-0010600	1		13-22
Bearing driver handle (A)	07749-0010000	1	Driver handle attachment 07949-6110000	12-15, 12-16, 13-17, 13-29, 14-6, 16-7
Valve spring compressor	07757-0010000	1	Valve spring compressor 07957-3290001	6-12, 6-18
Shock absorber compressor	07959-3290001	1		14-9, 14-10

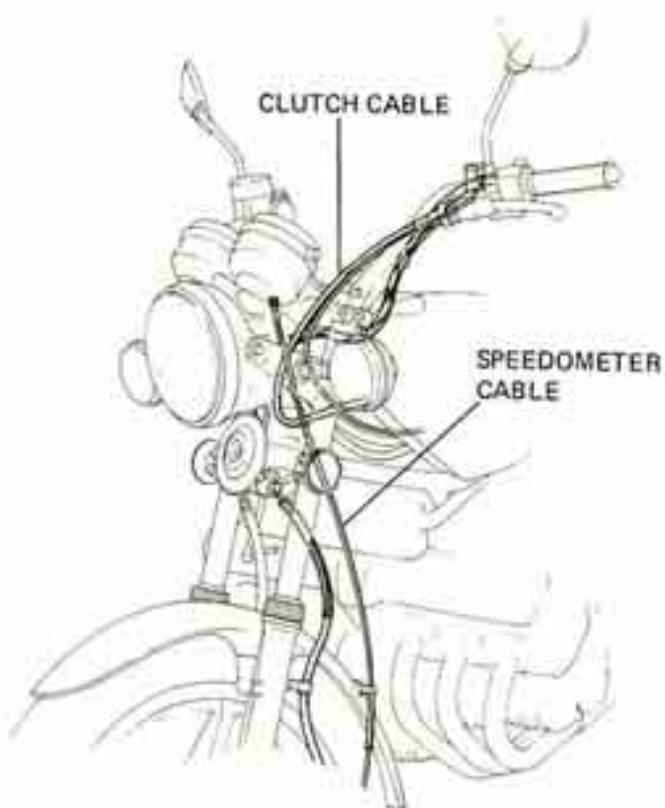
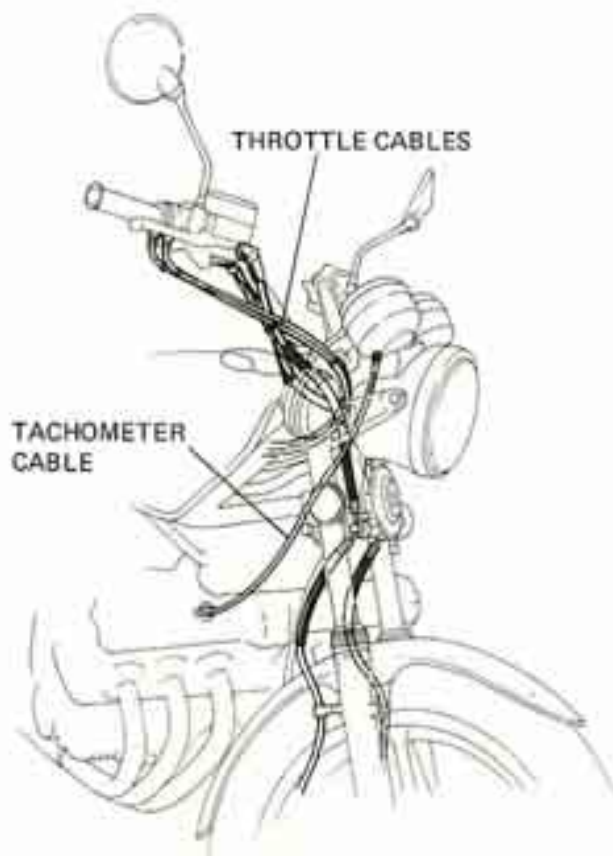
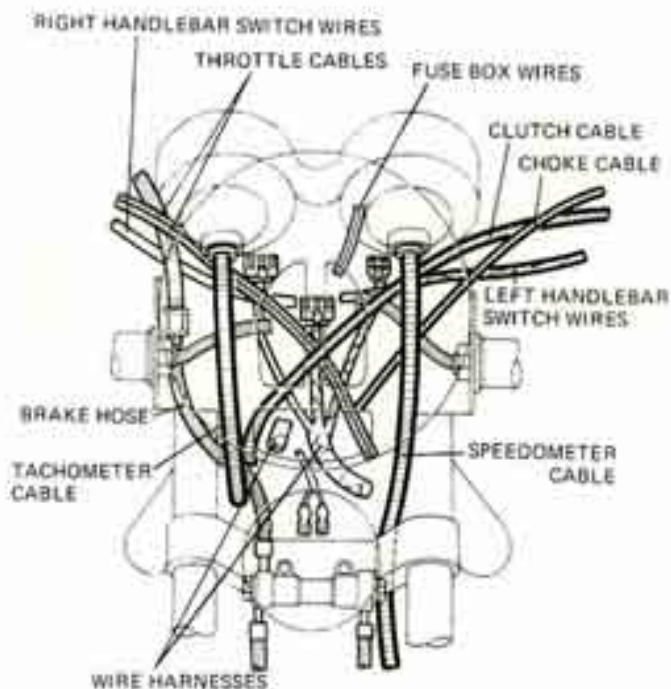
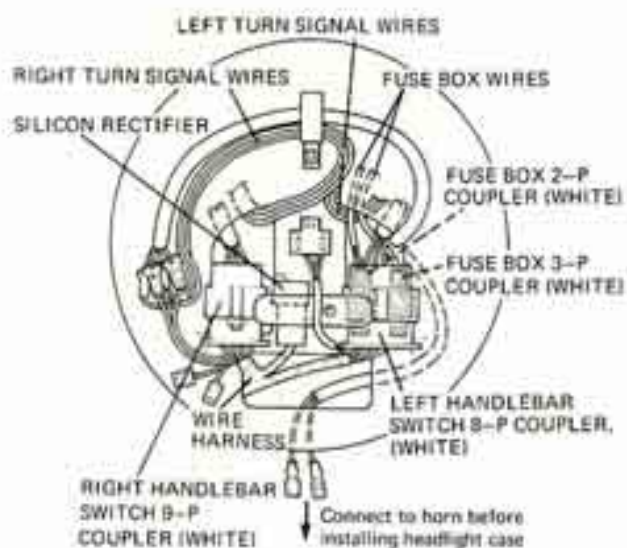

### IV. CABLE AND HARNESS ROUTING

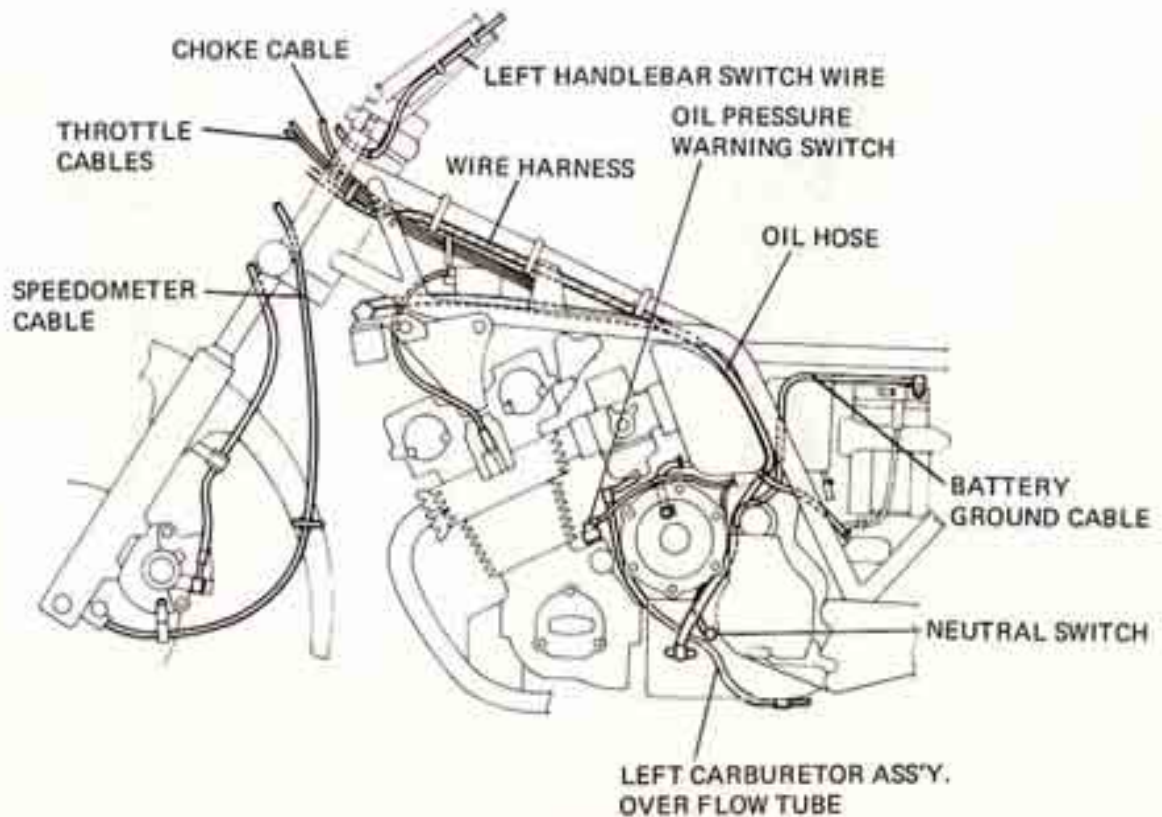
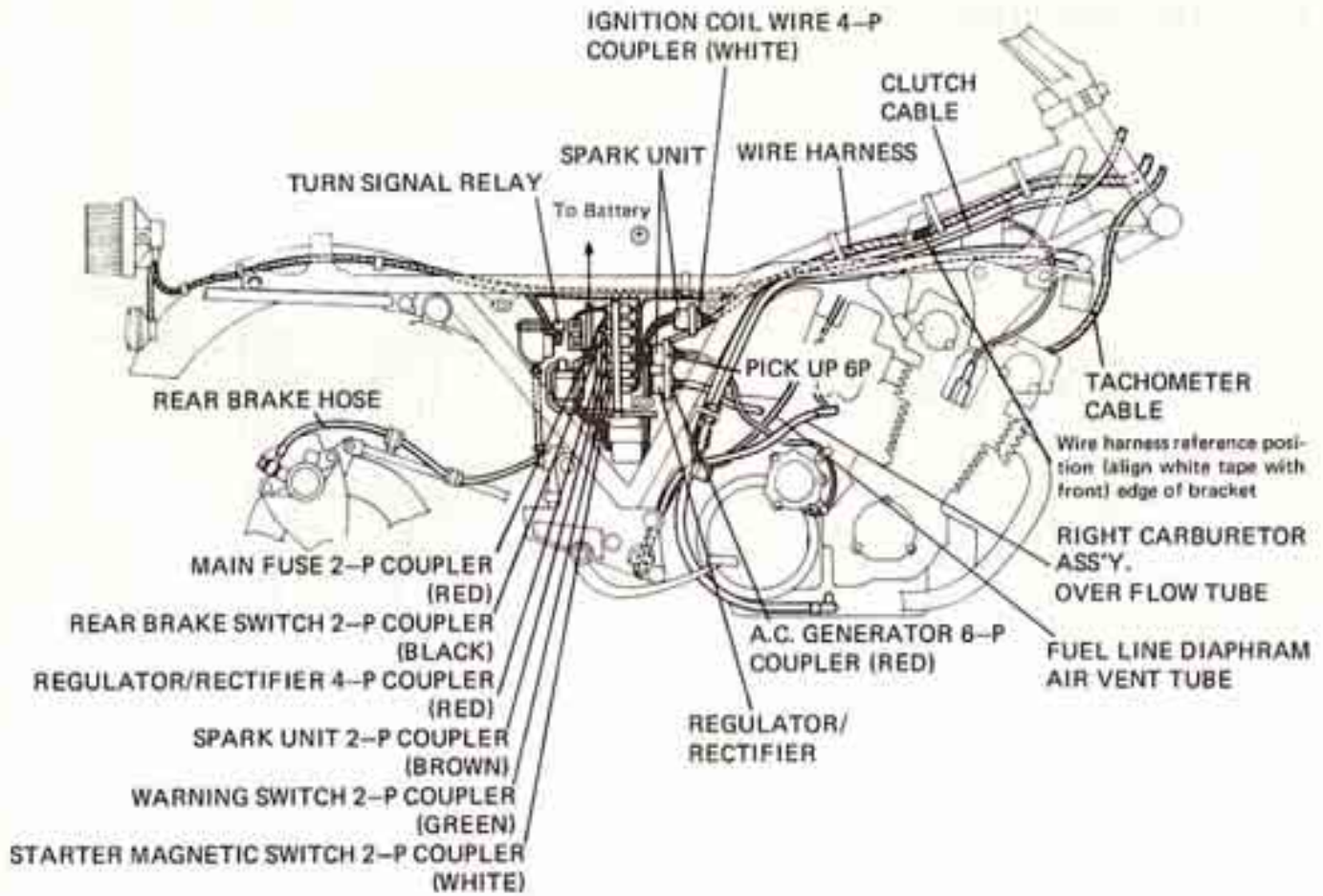







### V. MAINTENANCE SCHEDULE

Perform the PRE-RIDE INSPECTION in the Owner's Manual at each scheduled maintenance.

I: INSPECT AND CLEAN, ADJUST, LUBRICATE, OR REPLACE IF NECESSARY.

C: CLEAN                    A: ADJUST

R: REPLACE                L: LUBRICATE

ITEM	FREQUENCY	WHICHEVER COMES FIRST → ↓ EVERY	ODOMETER READING (NOTE 3)						Refer to
			600 mi. (1,000 km)	4,000 mi. (6,400 km)	8,000 mi. (12,800 km)	12,000 mi. (19,200 km)	16,000 mi. (25,600 km)	20,000 mi. (32,000 km)	
EMISSION RELATED ITEMS	* FUEL LINES		I	I	I	I	I	I	Page 3-3
	* THROTTLE OPERATION		I	I	I	I	I	I	Page 3-6
	* CARBURETOR CHOKE		I	I	I	I	I	I	Page 3-9
	AIR CLEANER	NOTE 1		C	C	C	C	C	Page 22-10
	CRANKCASE BREATHER	NOTE 2		C	C	C	C	C	Page 3-3
	SPARK PLUGS			R	R	R	R	R	Page 22-10
	* VALVE CLEARANCE		I	I	I	I	I	I	Page 3-10
	* IGNITION TIMING		I	I	I	I	I	I	Page 22-11
	ENGINE OIL	YEAR		R	R	R	R	R	Page 2-2
	ENGINE OIL FILTER	YEAR		R	R	R	R	R	Page 2-2
	* ENGINE OIL SCREEN					C			Page 2-3
	* CAM CHAIN TENSION		A	A	A	A	A	A	Page 3-14
	* CARBURETOR-SYNCHRONIZE		I	I	I	I	I	I	Page 22-13
	* CARBURETOR-IDLE SPEED		I	I	I	I	I	I	Page 3-9
NON-EMISSION RELATED ITEMS	DRIVE CHAIN		I, L EVERY 300 mi. (500 km)						Page 3-16
	BATTERY	MONTH	I	I	I	I	I	I	Page 3-17
	BRAKE FLUID	MONTH   2 YEARS *R	I	I	I	*R	I	I	Page 3-17
	BRAKE PAD WEAR			I	I	I	I	I	Page 3-18
	BRAKE SYSTEM		I	I	I	I	I	I	Page 3-18
	* BRAKE LIGHT SWITCH		I	I	I	I	I	I	Page 3-19
	* HEADLIGHT AIM		I	I	I	I	I	I	Page 3-19
	CLUTCH		I	I	I	I	I	I	Page 3-20
	SIDE STAND			I	I	I	I	I	Page 3-21
	* SUSPENSION		I	I	I	I	I	I	Page 3-22
	* NUTS, BOLTS, FASTENERS		I	I	I	I	I	I	Page 3-23
** WHEELS		I	I	I	I	I	I	Page 3-22	
** STEERING HEAD BEARING		I	I	I	I	I	I	Page 3-23	

\* SHOULD BE SERVICED BY AN AUTHORIZED HONDA DEALER, UNLESS THE OWNER HAS PROPER TOOLS AND SERVICE DATA AND IS MECHANICALLY QUALIFIED.

\*\* IN THE INTEREST OF SAFETY, WE RECOMMEND THESE ITEMS BE SERVICED ONLY BY AN AUTHORIZED HONDA DEALER.

NOTES: 1. SERVICE MORE FREQUENTLY WHEN RIDING IN DUSTY AREAS.

2. SERVICE MORE FREQUENTLY WHEN RIDING IN RAIN OR AT FULL THROTTLE (USA ONLY).

3. FOR HIGHER ODOMETER READINGS, REPEAT AT THE FREQUENCY INTERVAL ESTABLISHED HERE.



## VI. INSPECTION AND ADJUSTMENT

### AIR CLEANER

Remove the seat (page 5-2).

Lift the air cleaner cover clip up.

Remove the two air cleaner cover screws and the air cleaner cover.

Remove the air cleaner element set spring. Remove the air cleaner element.

Clean the element (Page 3-3). Install the removed parts (Page 3-3).

Snap the air cleaner cover clip into place.



### SPARK PLUGS

#### RECOMMENDED SPARK PLUG

( ) Canada model

For cold climate below 5°C (41°F)		Standard		For extending high speed riding	
ND	NGK	ND	NGK	ND	NGK
X22ES-U (X22ESR-U)	D7EA (DR7ES)	X24ES-U (X24ESR-U)	D8EA (DR8ES-L)	X27ES-U (X27ESR-U)	D9EA (DR8ES)

Clean any dirt from around the spark plug base.

Disconnect the spark plug caps.

Remove and discard the spark plugs.

Measure the new spark plug gaps using a wire-type feeler gauge.

**SPARK PLUG GAP: 0.6–0.7 mm  
(0.024–0.028 in)**

Adjust by bending the side electrode carefully.

With the plug washer attached, thread the new spark plugs in by hand to prevent cross-threading.

Tighten the spark plugs another 1/2 turn with a spark plug wrench to compress the plug washer.

Connect the spark plug caps.

### CONTROL CABLE LUBRICATION

Periodically, disconnect the throttle and clutch cables at their upper ends.

Thoroughly lubricate the cables and their pivot points with a commercially available cable lubricant.

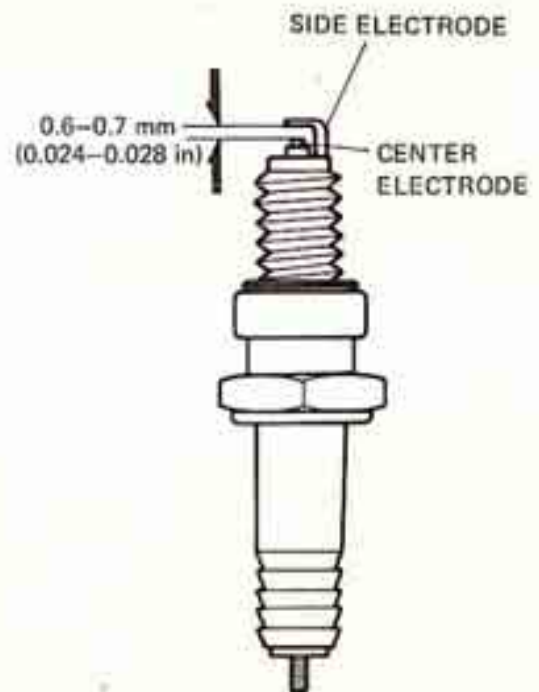





### IGNITION TIMING

#### NOTE

Can be done with oil in the engine.

Remove the right crankcase cap and pulser generator cover.

Rotate the crankshaft clockwise and align the "F" mark with the crankcase front upper and lower mating surface.

Either No. 6 or No. 1 piston must be near TDC of the compression stroke.

The timing is correct if the narrow projection of 1,6 pulser generator is aligned with the rotor tooth.

If the ignition timing is incorrect, loosen the three pulser generator base plate locking screws.

Rotating the base plate counterclockwise will advance the ignition timing.

Rotating the base plate clockwise will retard the ignition timing.

Tighten the base plate locking screws and recheck the ignition timing.

Install the removed parts.

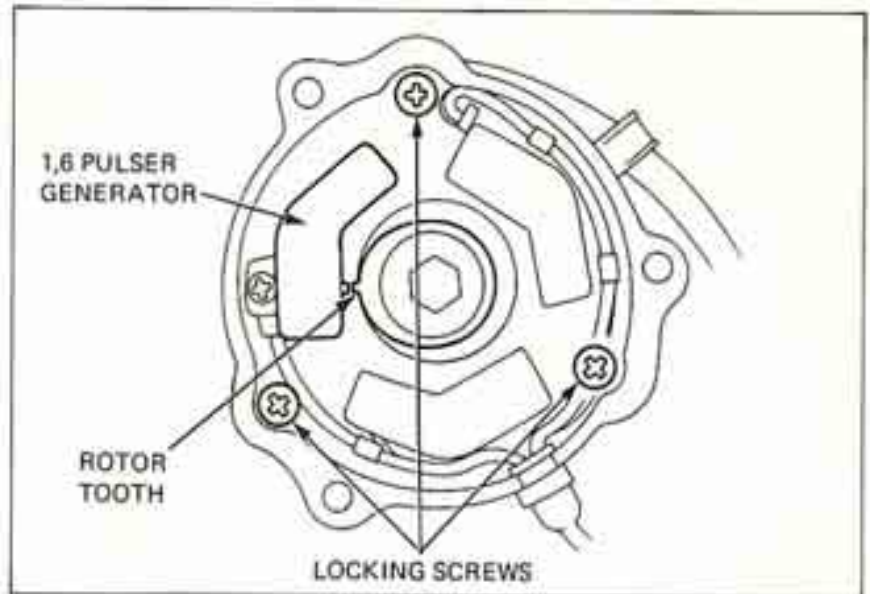

### SPARK ADVANCER

#### NOTE

- Check the spark advancer only if engine performance difficulties occur.
- A high quality stroboscopic timing light designed for transistorized ignition systems must be used. It should also be capable of accurate operation at 9,000 rpm.

Remove the pulser cover.

Remove the rotor bolt and install the special degree wheel. (07974-4220002).

Align initial mark on the degree wheel with the rotor tooth and tighten the rotor bolt.

Connect a timing light to the No. 6 high tension wire.

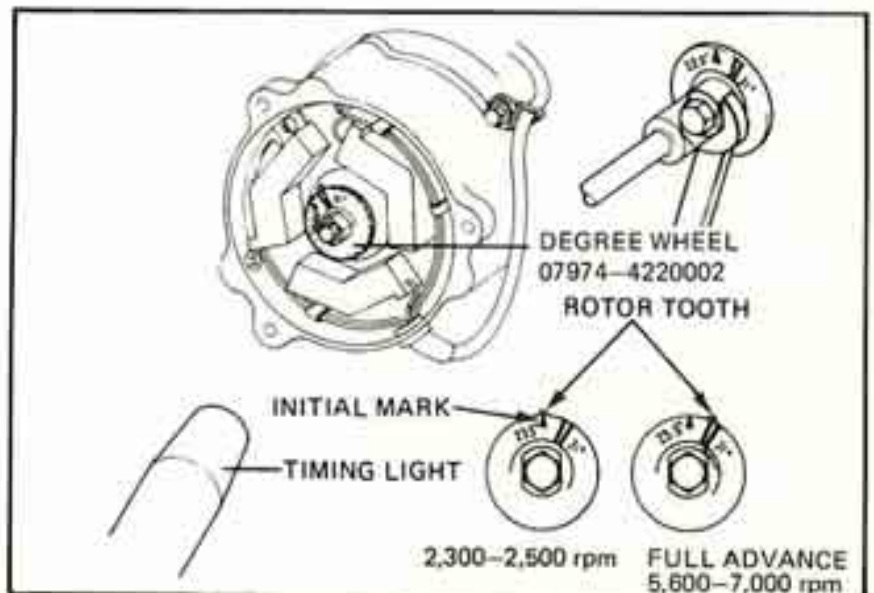





Start the engine.

Check that the initial mark remains aligned with the rotor tooth at idle.

Increase engine speed and check that the 23.5° mark aligns with the rotor tooth at 2,300–2,500 rpm.

And then check that the 31° mark aligns with the rotor tooth at 5,600–7,000 rpm.

### NOTE:

The degree wheels for the '79 model CBX (H/C 71955 T/N 07974-4220000 or H/C 84396 T/N 07974-4220002) can be used on the '80 model CBX. Just be sure to check 31° advance at 5,600–7,000 rpm instead of 8,000 rpm as shown on these degree wheels.

### CAUTION

Do not allow engine speed to exceed 8,000 rpm or engine damage may result.

Replace the advancer assembly if it is not functioning properly.  
Install the pulser cover.

## ENGINE OIL

Recommended oil:

- Use HONDA 4-STROKE OIL or equivalent.
- API service classification – SE
- Viscosity – SAE 10W-40
- Other oil viscosities may be used when the average temperature in your riding area is within the indicated range.

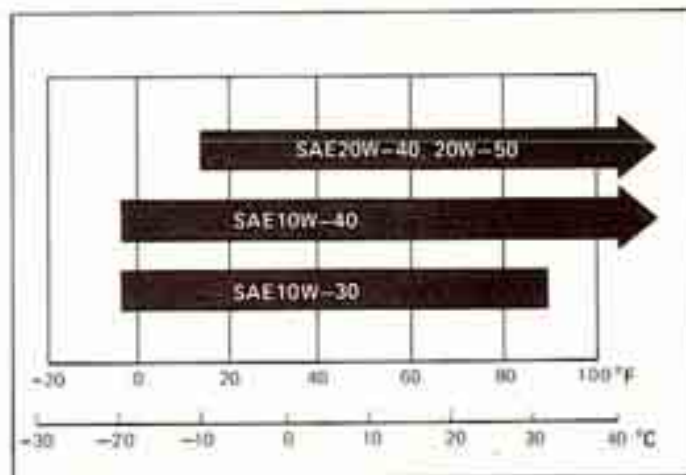
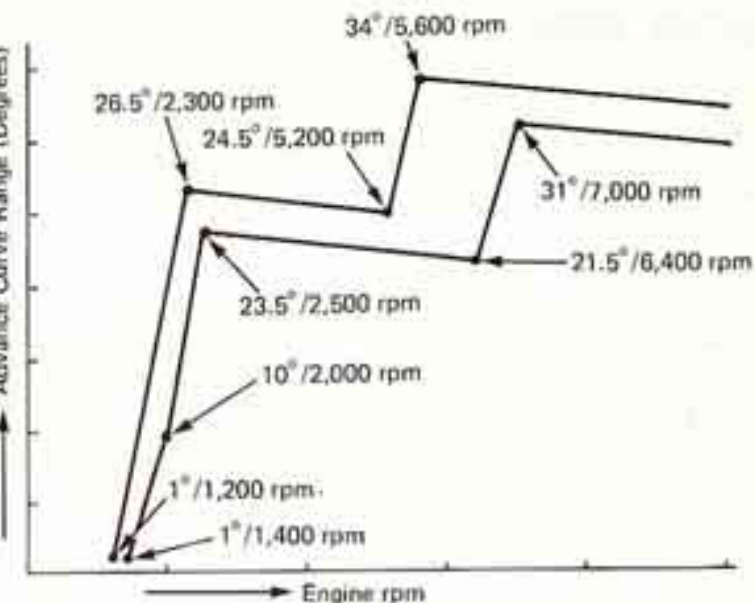

## CARBURETOR SYNCHRONIZATION

### NOTE

Perform the carburetor synchronization with engine at normal operating temperature, transmission in neutral and motorcycle on the center stand.

Remove the seat and air cleaner inlet duct.  
Turn the fuel valve OFF and remove the fuel tube and fuel tank.  
Prepare a longer fuel tube and reconnect it to the fuel tank and carburetor.  
Position the fuel tank higher than its normal position.



Remove the vacuum plugs from the carburetors (except the No. 3). Install long adapters to the inner carburetors and short adapters to the outer carburetors.  
Connect the vacuum gauges.

Start the engine.  
Clamp the No. 3 carburetor vacuum tube shut to hold the fuel diaphragm open.  
Stop the engine.  
Remove the vacuum tube from the No. 3 carburetor.  
Connect the vacuum gauge to the No. 3 carburetor.

### NOTE

If the vacuum gauge tube I.D. is over 6 mm (1/4 in), connect an adapter tube (No. 95005-35085-20) and joint (No. 36025-657-671) to the No. 3 carburetor.

### CAUTION

*Do not attempt to remove the No. 3 carburetor vacuum tube connector. Carburetor damage may result.*

Restart the engine and adjust the idle speed to 900 rpm.

Make sure that the maximum difference in vacuum reading is not more than 40 mm Hg (1.6 in Hg).

For adjustment, refer to the base manual (Page 3-8).

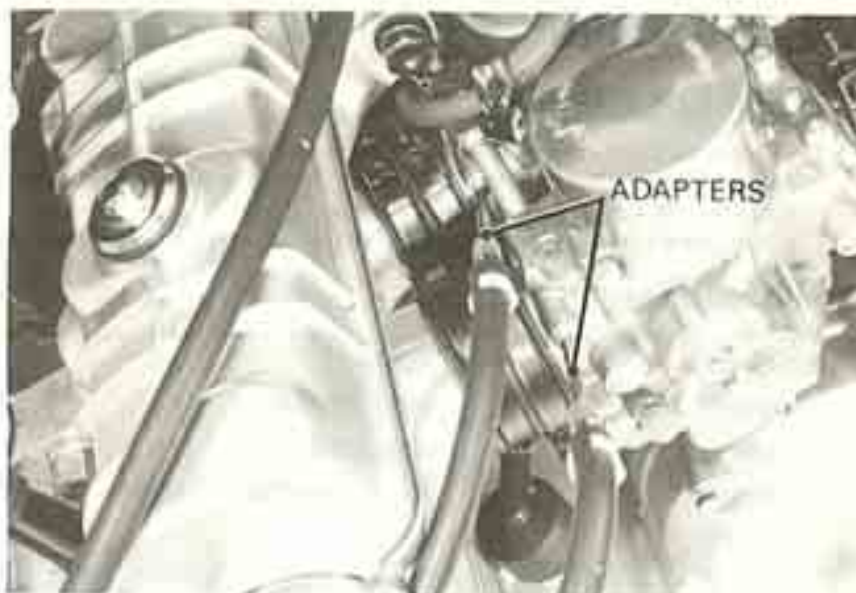





## VII. FUEL SYSTEM

### GENERAL INFORMATION

- The carburetors are equipped with a fuel line diaphragm. After carburetor overhaul, it is necessary to crank the engine for 2-3 seconds, three times with the throttle fully closed to fill the float chambers.
- Refer to section 4 for carburetor adjustments.
- The pilot screw is factory pre-set and should not be removed unless the carburetor is overhauled.

### CARBURETOR SPECIFICATIONS

Identification mark	VB62A
Idle speed	900 ± 100 rpm
Fast idle	2000 ± 500 rpm
Float level	15.5 ± 1 mm (0.61 ± 0.04 in)
Venturi dia.	28 mm (1.1 in)
Main jet	#110

### TROUBLESHOOTING

#### Fuel line diaphragm

- Fuel not reaching carburetors
  1. Fuel line diaphragm vent tube clogged
  2. Fuel line diaphragm vacuum tube clogged
  3. Clogged fuel line diaphragm.
  4. Clogged fuel line diaphragm check valve

### CARBURETOR DISASSEMBLY AND ASSEMBLY

For details, refer to the base manual.

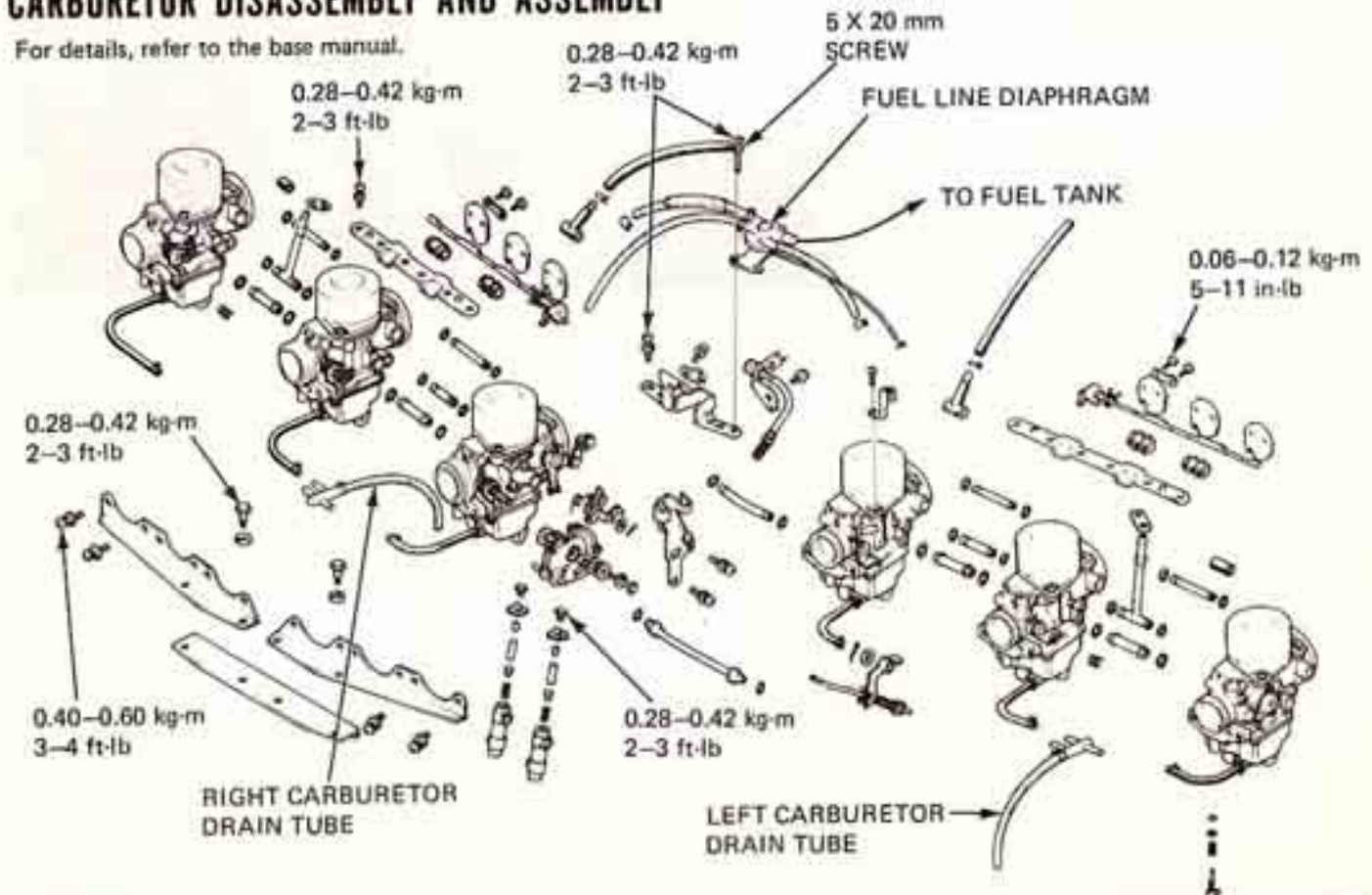





### FUEL LINE DIAPHRAGM

#### REMOVAL

Turn the fuel valve off. Remove the seat and fuel tank.

Disconnect the fuel tube, vacuum tube and air vent tube.

Unscrew the screws attaching the fuel line diaphragm to the carburetors. Remove the fuel line diaphragm.

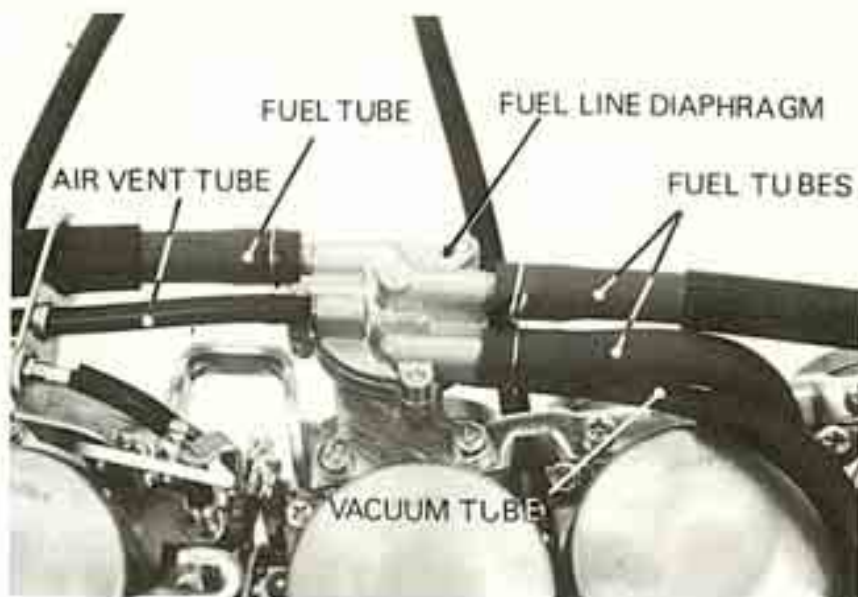

#### INSPECTION

Remove the fuel line diaphragm (see above).

Disconnect the inlet fuel tube from the diaphragm, and connect a longer tube to the fuel tank.

Place a suitable drainage container under the outlet fuel tubes.

Turn the fuel valve on. Fuel should not flow from the outlet tubes.

Connect a vacuum gauge to the diaphragm vacuum outlet. Fuel should flow out from the outlet tubes when 10–20 mm Hg (0.4–0.8 in Hg) of vacuum is applied.

If the flow is restricted, check the diaphragm for clogged fuel or air passages and the diaphragm itself for tears.

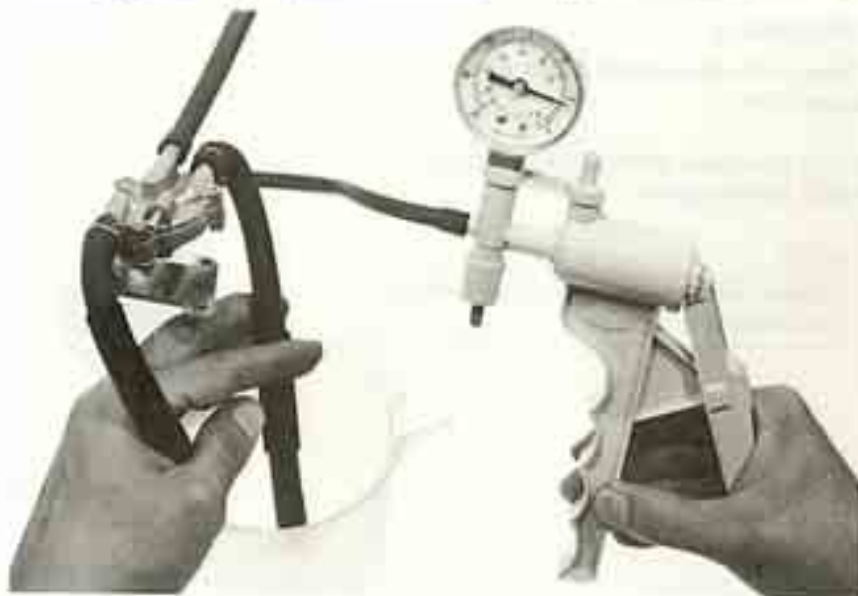

#### DISASSEMBLY

Disassemble the upper body, spacer, spring and lower body by removing the screws shown.

Disassemble the spacer, being careful not to damage the diaphragm.





## '80 ADDENDUM

Check the upper and lower bodies for signs of damage to the diaphragm contacting faces.

Check the diaphragm for damage, cracks or other defects.

Check the bodies and spacer for clogged vent holes.

Check the diaphragm seal for damage.

Check for clogged fuel or air passages.

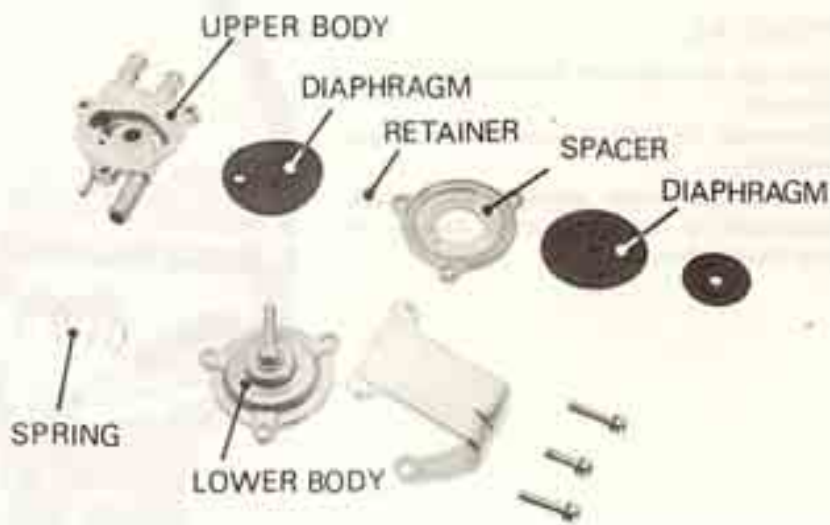

### ASSEMBLY

Clean all the disassembled parts in solvent and allow to dry.

Install the spacer and diaphragm retainer.  
Install the spring seat.

#### NOTE

Check that the diaphragm is installed in the retainer properly.

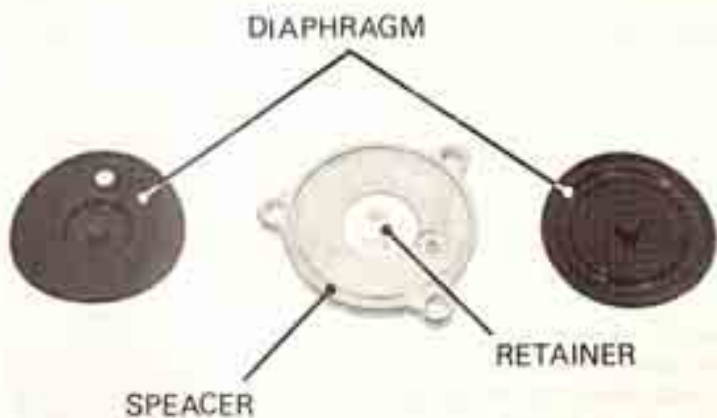

Install the spacer on the upper body.

#### NOTE

Align the air vent hole in the body with the air passage in the spacer.

Install the diaphragm spring and lower body.  
Install the bracket and tighten with the screws.

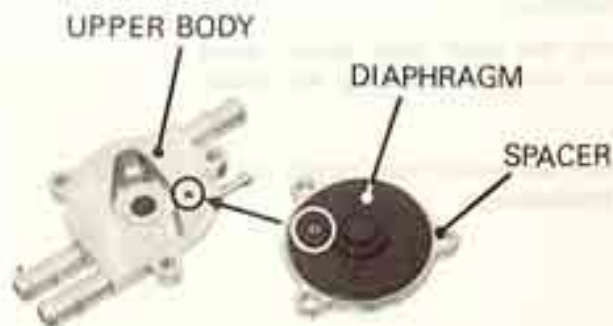



## INSTALLATION

Installation of the fuel line diaphragm is the reverse of removal.

### NOTE

Check that air or gasoline is not leaking past the fuel tube joints or connections.

## CARBURETOR TUBE ROUTING

Route the carburetor tubes as shown.

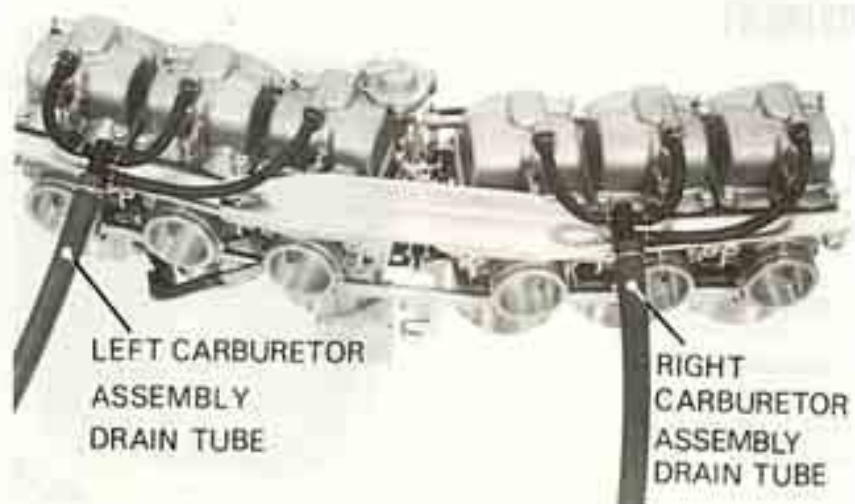
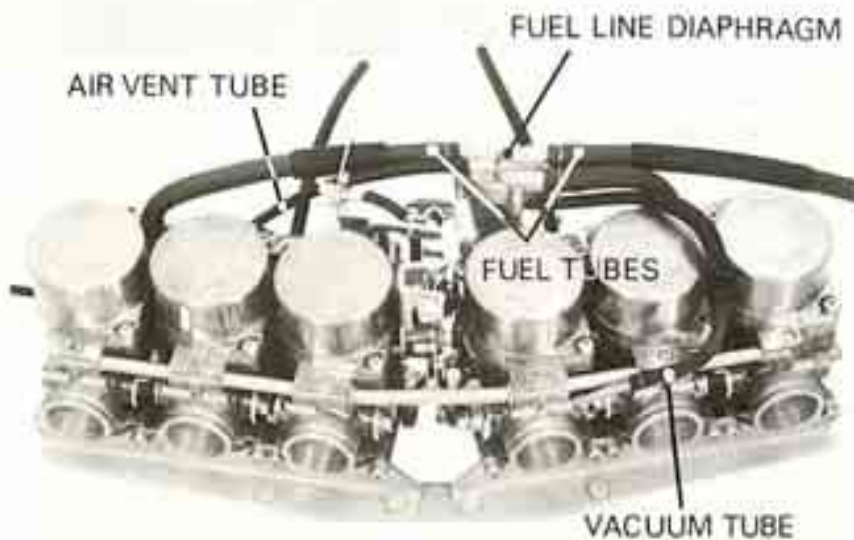





## PILOT SCREW REMOVAL/ INSTALLATION

### NOTE

The pilot screws are factory pre-set and should not be removed unless the carburetor is overhauled.

Remove the carburetors. (Page 4-3).

Remove the float chambers (Page 4-6).

Turn the pilot screw in and carefully count the number of turns before it seats lightly. Make a note of this to use as a reference when reinstalling the pilot screw.

### CAUTION

*Damage to the pilot screw seat will occur if the pilot screw is tightened against the seat.*

Remove the pilot screw.

Inspect the pilot screw and replace if worn or damaged.

Install the pilot screw and return it to its original position as noted during removal. Perform pilot screw adjustment if a new pilot screw is installed (below).

### NOTE

Do not install limiter caps on new pilot screws until after adjustment has been made (below).

## PILOT SCREW ADJUSTMENT

### NOTE

- The pilot screws are factory pre-set and no adjustment is necessary unless the pilot screw is replaced (See removal above).
- Use a tachometer with graduations of 50 rpm or smaller and that will accurately indicate a 50 rpm change.

1. Turn each pilot screw clockwise until it seats lightly and back it out to the specification given. This is an initial setting prior to the final pilot screw adjustment

**INITIAL OPENING: 1-1/4 turns out**

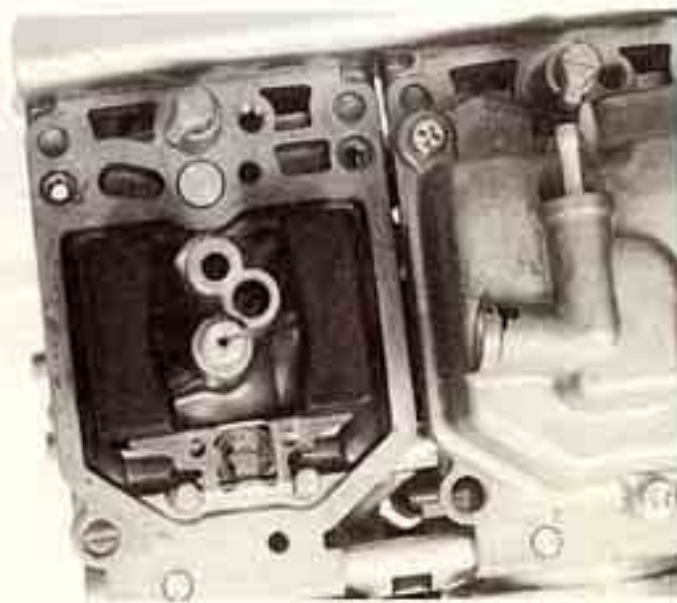
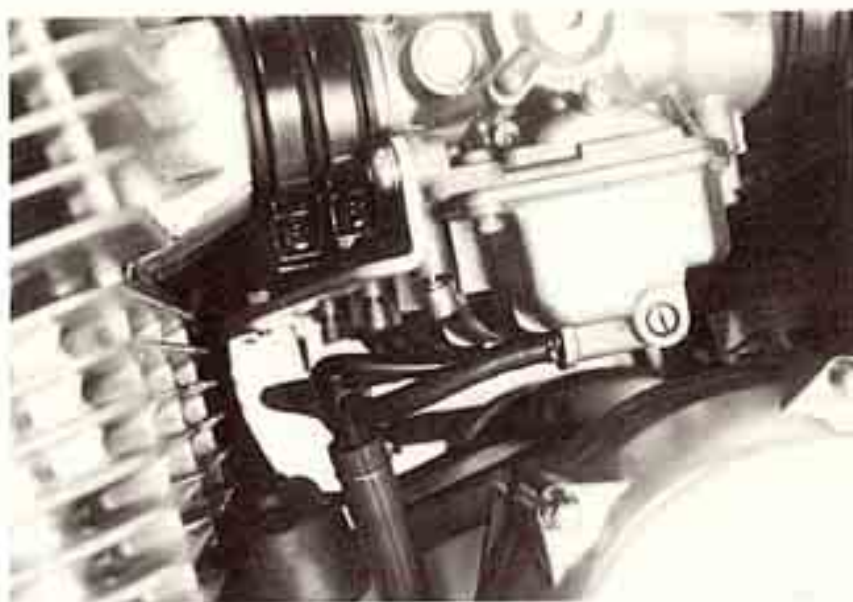



**CAUTION**

*Damage to the pilot screw seat will occur if the pilot screw is tightened against the seat.*

2. Warm up the engine to operating temperature. Stop and go driving for 10 minutes is sufficient.
3. Attach a tachometer.
4. Adjust the idle speed with the throttle stop screw.

**IDLE SPEED: 900 rpm**

5. Turn each pilot screw in or out to obtain the highest engine speed.
6. Adjust the idle speed with the throttle stop screw.
7. Turn the No. 1 carburetor pilot screw in until it seats lightly, recording the number of turns.
8. Turn the No. 2 carburetor pilot screw in until the engine speed drops 50 rpm.
9. Turn the No. 2 carburetor pilot screw 1/2 turn out from the position obtained in Step 7.
10. Perform Steps 8 and 9 for the No. 3, 4, 5 and 6 carburetor pilot screws.
11. Turn the No. 1 pilot screw the number of turns recorded in step 7.
12. Turn the No. 6 pilot screw in until it seats lightly, recording the number of turns.
13. Perform Steps 8 and 9 for the No. 1 carburetor pilot screw.
14. Turn the No. 6 pilot screw out the number of turns recorded in Step 12.
15. Adjust the idle speed with the throttle stop screw.

**LIMITER CAP INSTALLATION**

If the pilot screw is replaced, a new limiter cap must be installed after pilot screw adjustment is completed.

After adjustment, cement the limiter cap over the pilot screw, using LOCTTE © 601 or equivalent. The limiter cap should be placed against its stop, preventing further adjustment that would enrich the fuel mixture (limiter cap position permits clockwise rotation and prevents counterclockwise rotation).

**NOTE**

A pilot screw limiter cap must be installed. It prevents misadjustment that could cause poor performance and increase exhaust emissions.

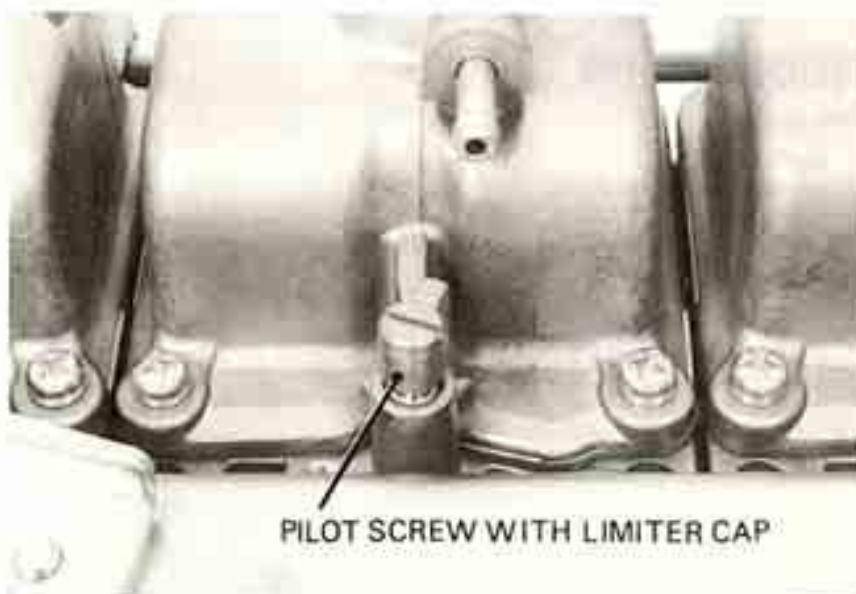

PILOT SCREW WITH LIMITER CAP

**VIII. CYLINDER HEAD/VALVES**

**CAM HEIGHT INSPECTION**

Using a micrometer, check each cam lobe height for wear or damage.

		STANDARD	SERVICE LIMIT
CAM LOBE HEIGHT	IN	37.800–37.060 mm (1.4882–1.4945 in)	37.7 mm (1.48 in)
	EX	37.800–37.160 mm (1.4567–1.4630 in)	36.9 mm (1.45 in)





## IX. FRONT WHEEL/SUSPENSION

### GENERAL INFORMATION

- The '80 CBX uses an air assist fork front suspension system. The front fork preload can be changed by adjusting the amount of air pressure in each front fork tube.

### TORQUE

Steering stem adjusting nut	1.1–1.3 kg-m (8–9 ft-lb)
Front fork air valve	0.4–0.7 kg-cm (3–5 in-lb)
Front fork cap bolt	1.5–3.0 kg-m (11–22 ft-lb)
Front fork socket bolt	1.5–2.5 kg-m (11–18 ft-lb)

### SPECIFICATIONS

	STANDARD	SERVICE LIMIT
Fork spring free length	551.0 mm (26.89 in)	541 mm (21.3 in)
Front fork slider I.D.	36.042–36.084 mm (1.4190–1.4192 in)	36.20 mm (1.425 in)
Front fork tube O.D.	34.925–34.950 mm (1.3750–1.3760 in)	34.85 mm (1.372 in)
Front fork oil capacity	240 cc (8.2 ozs)	_____
Front fork air pressure	0.5–0.9 kg/cm <sup>2</sup> (7–13 psi)	_____
Front fork slider bushing O.D.	36.00–35.94 mm (1.417–1.413 in)	35.85 mm (1.411 in)
Front fork guide bushing I.D.	35.07–35.13 mm (1.381–1.383 in)	35.25 mm (1.388 in)

### TROUBLESHOOTING

#### Soft Suspension

- Weak fork springs.
- Insufficient fluid in forks.
- Low air pressure.

#### Hard Suspension

- Incorrect fluid weight in forks.
- Excessive air pressure in fork tube.
- Excessive oil amount in forks.

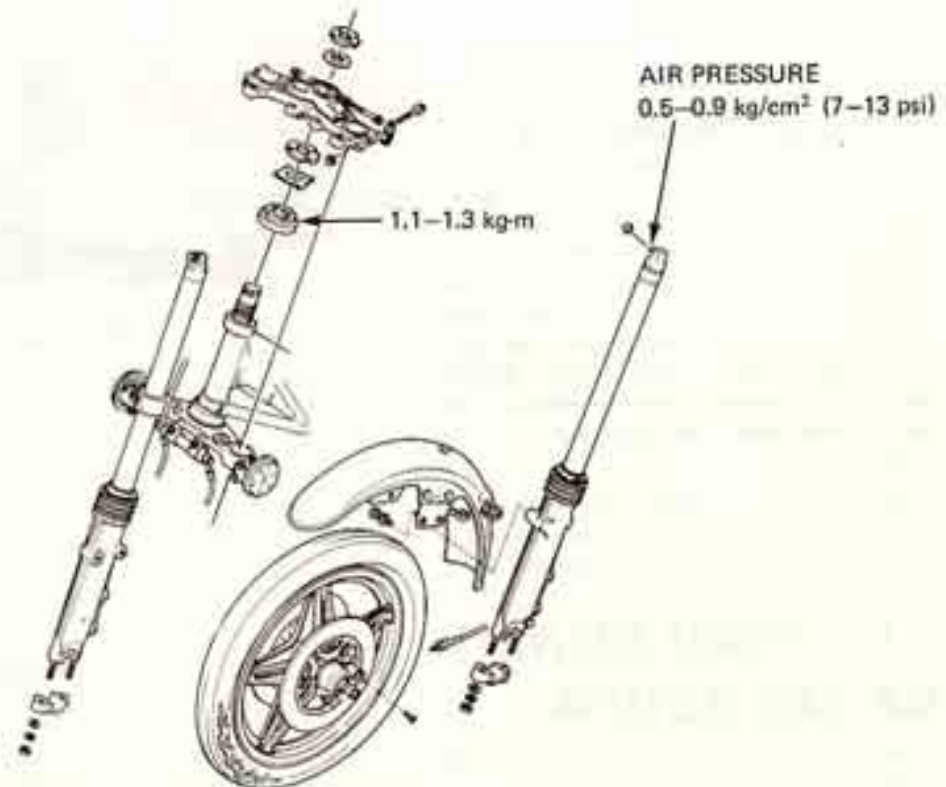





### FRONT FORK DISASSEMBLY

Remove the front fork (Pages 13-19 and 20).

Depress the valve stem to relieve air pressure.

**CAUTION**

*DO NOT disassemble the forks until air pressure is relieved.*

Unscrew the fork cap bolts and drain the fork leg. Remove the fork spring.

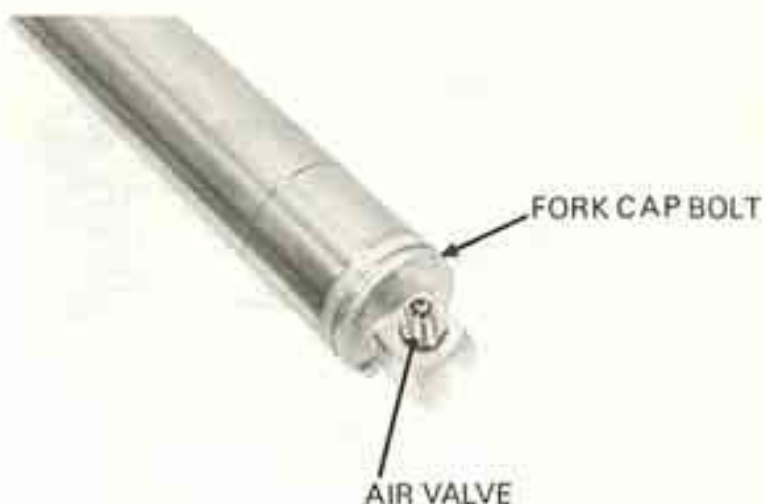

Remove the socket bolt.  
Remove the fork piston and rebound spring.

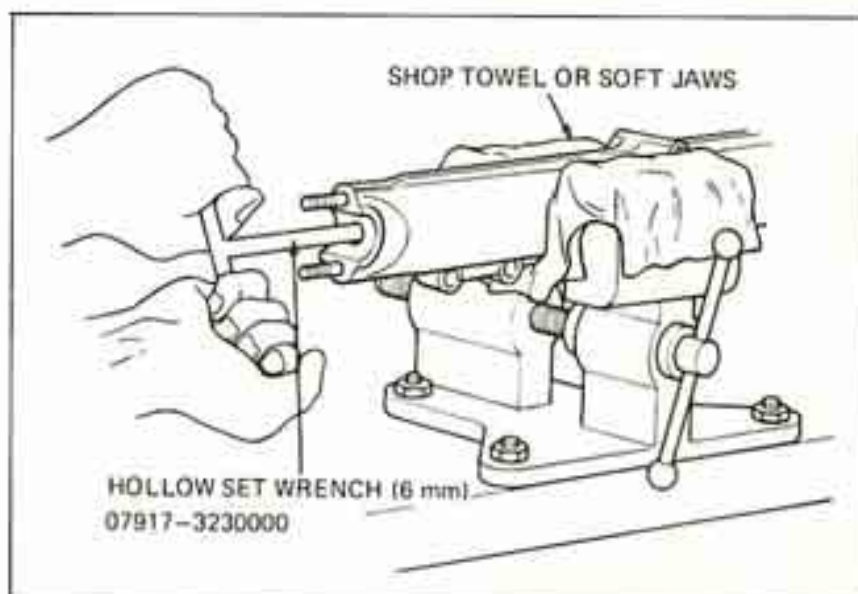

Remove the dust seal.  
Remove the circlip and plain washer.  
Pull the fork tube out of the slider.

Remove the oil seal, back up ring and guide bushing from the fork slider.

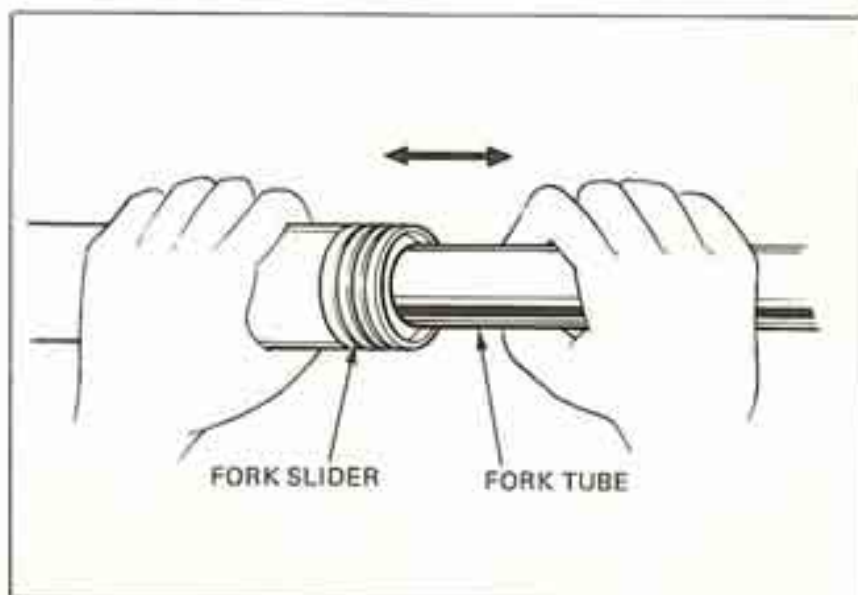

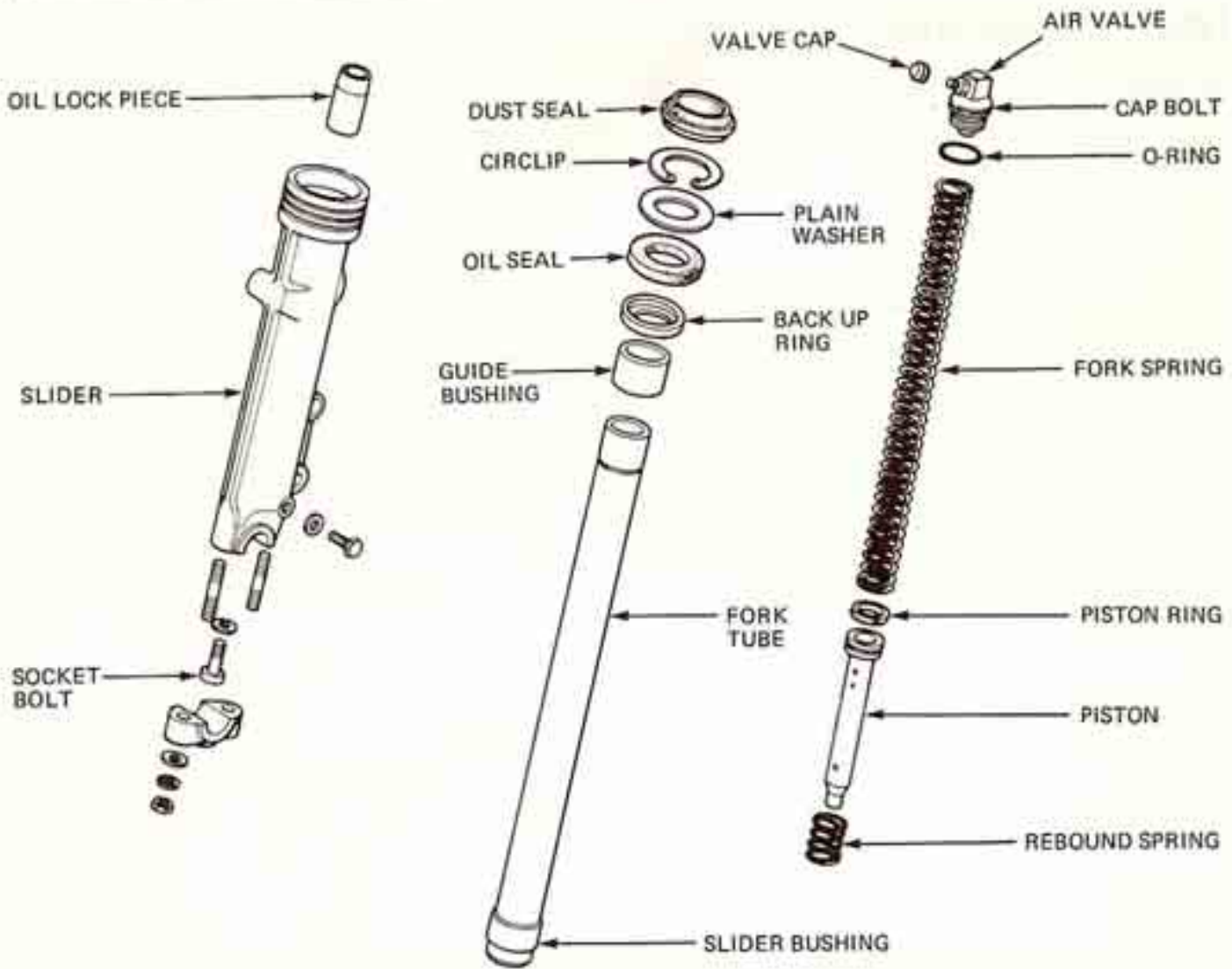

## FRONT FORK ASSEMBLY

Install the rebound spring and piston into the fork slider.

Install the fork spring and tighten the cap bolt loosely.

Install the oil lock piece and fork tube into the slider by aligning the oil lock piece with the fork tube.

Apply a locking agent to the socket bolt and tighten.

**TORQUE: 1.5-2.5 kg-m (11-18 ft-lb)**



Install the guide bushing into the slider.

Install the backup ring.

Dip the new fork seal in ATF and install it into the slider.

Drive the oil seal into position until the circlip groove appears.

Install the backup ring washer.

Install the circlip and dust cover.

### NOTE

Install the circlip with the round edge down.

Remove the cap bolt.

Fill the fork tube with ATF.

**OIL CAPACITY: 240 cc (8.2 ozs)**

Install and tighten the cap bolt.

**TORQUE: 1.5–3.0 kg-m (11–22 ft-lb).**

Fill the fork tube with  $0.7 \pm 0.2 \text{ kg/cm}^2$  pressure of air.

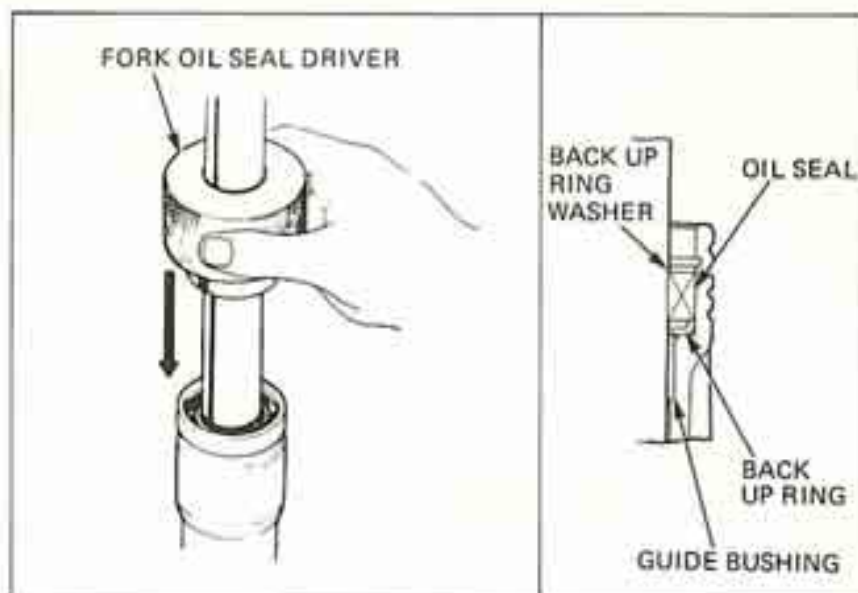

## FRONT FORK INSTALLATION

For front fork installation, refer to page 13-24. Adjust the front fork air pressure as follows.

With the front brake applied, pump the front forks up and down several times.

Place the motorcycle on the center stand.

Measure the air pressure.

**STANDARD:  $0.7 \pm 0.2 \text{ kg/m}^2$  ( $10 \pm 3 \text{ psi}$ )**

### CAUTION

- Use only a hand operated air pump to fill the fork tubes. Do not use compressed air.
- Maximum pressure is  $3 \text{ kg/cm}^2$  (43 psi). Do not exceed this or fork tube component damage may occur.







## STEERING STEM

### STEM REMOVAL

Remove the fork top bridge (Page 13-25).  
 Straighten the lock washer tabs.  
 Remove the top-thread "B" nut and lock washer.  
 Remove the bearing adjustment nut.

#### STEERING STEM SOCKET

07916-3710100

Remove the steering stem.

Remove the upper bearing and bearing holder.  
 Remove the lower bearing and dust seal.  
 Install the lower bearing and dust seal (Page 13-26).  
 Remove the upper and lower bearing outer races (Page 13-26).  
 Install the upper and lower bearing outer races (Page 13-27).

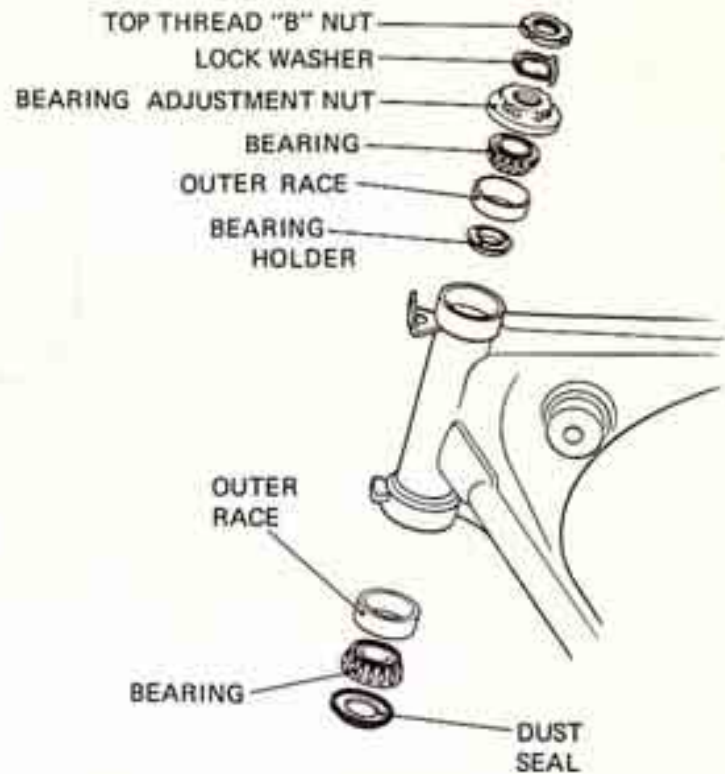

### STEERING STEM INSTALLATION

Clean the upper and lower bearings thoroughly.  
 Thread the bearing adjustment nut and top thread "B" nut onto the steering stem to make sure that they turn smoothly and will not bind.

Remove the top thread "B" nut and adjustment nut.

Clean the steering stem and adjustment nut threads. Remove all dirt and burrs.

Pack all bearing cavities with bearing grease.  
 Insert the steering stem into the steering head pipe.

Install the upper bearing holder and bearing.

Install and tighten the adjustment nut.

**TORQUE: 1.1-1.3 kg-m (8-9 ft-lb)**





Turn the steering stem lock-to-lock 5 times to seat the bearings.

Repeat the bearing tightening and steering stem turning sequence twice.

If the nut does not tighten after turning the steering stem the first or second time, remove the nut and inspect it and the steering stem threads for dirt or burrs.



Install a new bearing adjustment nut lock washer aligning the tabs with the nuts grooves.

**NOTE**

DO NOT install a used bearing adjustment nut lock washer.

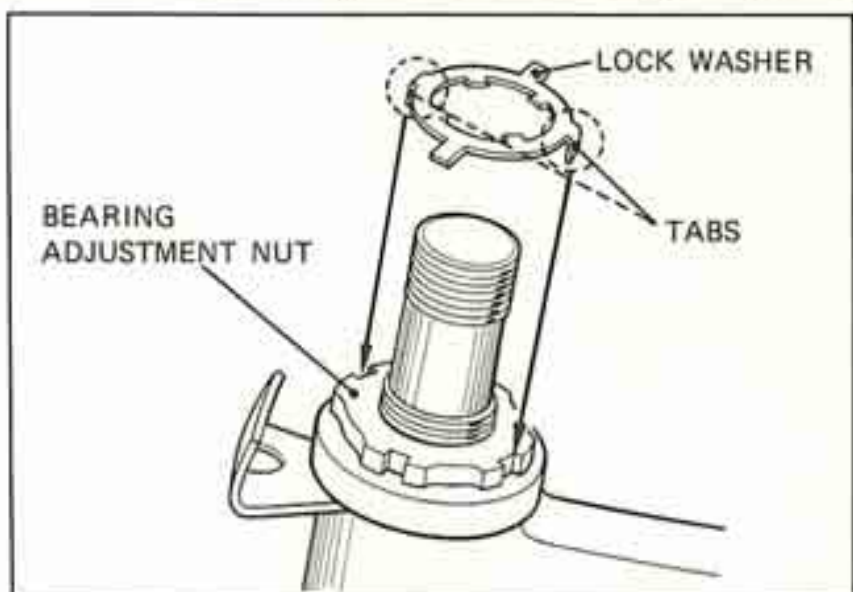

Hand tighten the top thread "B" nut. Hold the adjustment nut and further tighten the "B" nut only to align its grooves with the lock washer tabs.

**NOTE**

If the top thread "B" nut grooves cannot be easily aligned with the lock washer tabs, remove the nut, turn it over and reinstall.

Bend the other two lock washer tabs up into the top thread "B" nut grooves.

Install the top bridge (Pages 13-27 and 28).

Check that the steering stem rotates freely and that there is no vertical movement.

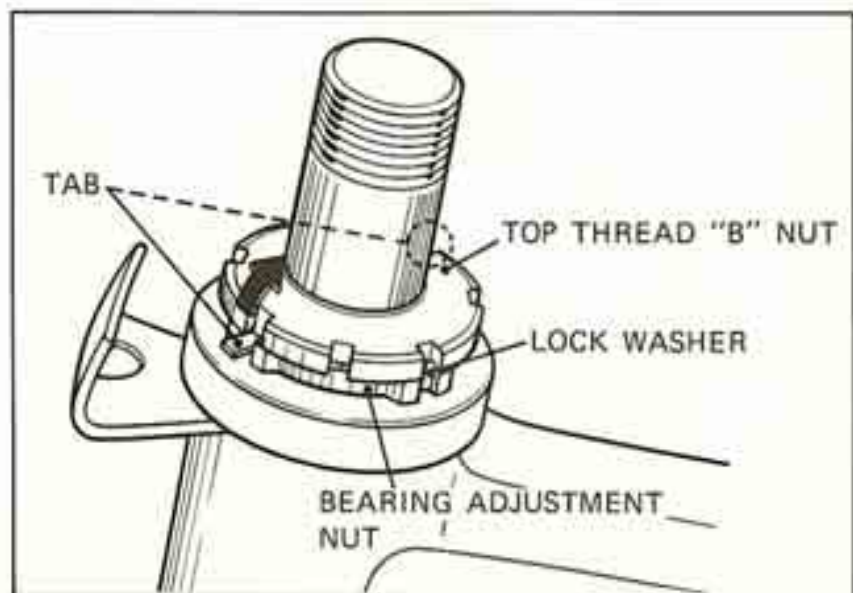



## X. REAR WHEEL/SUSPENSION

### GENERAL INFORMATION

#### SPECIFICATIONS

		STANDARD	SERVICE LIMIT
Axle runout		————	0.2 mm (0.008 in)
Rear wheel rim runout	Radial	————	2.0 mm (0.08 in)
	Axial	————	2.0 mm (0.08 in)
Shock absorber spring free length		254.2 mm (10.0 in)	249.5 mm (9.82 in)

#### TORQUE VALUES

Swing arm right pivot collar	3.0–4.0 kg-m (22–29 ft-lb)
Swing arm left pivot collar	2.5–3.0 kg-m (18–22 ft-lb)
Left pivot piece lock nut	4.5–5.5 kg-m (33–40 ft-lb)
Swing arm pivot bolt	7.0–8.0 kg-m (51–58 ft-lb)

### TROUBLESHOOTING

#### Wobble or Vibration in Motorcycle

1. Bent rim
2. Loose wheel bearing
3. Loose or distorted spokes
4. Faulty tire
5. Loose axle
6. Tire pressure incorrect
7. Swing arm bearings worn

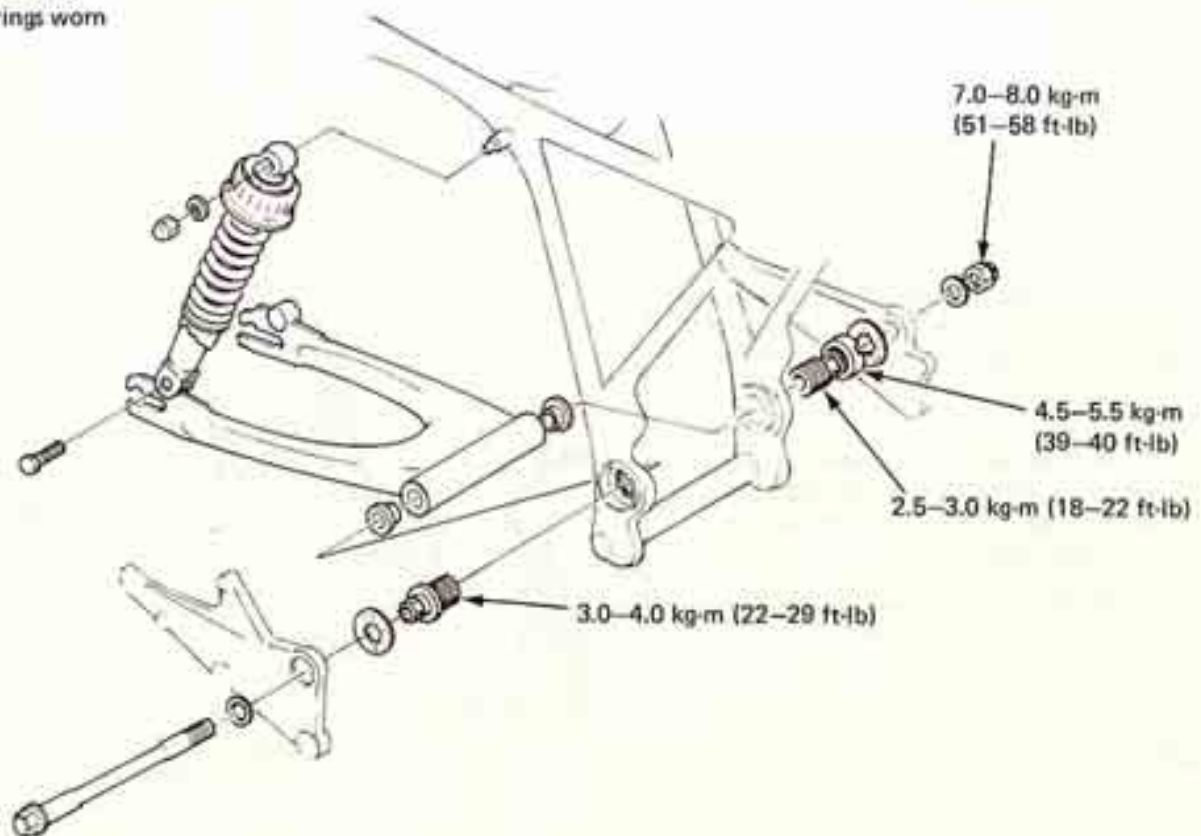





## REAR SHOCK ABSORBER DISASSEMBLY

Remove the rear shock absorber (Page 14-8).

### NOTE

Wrap the spring case with tape to prevent damage.

Compress the spring just enough to remove the adjuster and remove the parts.

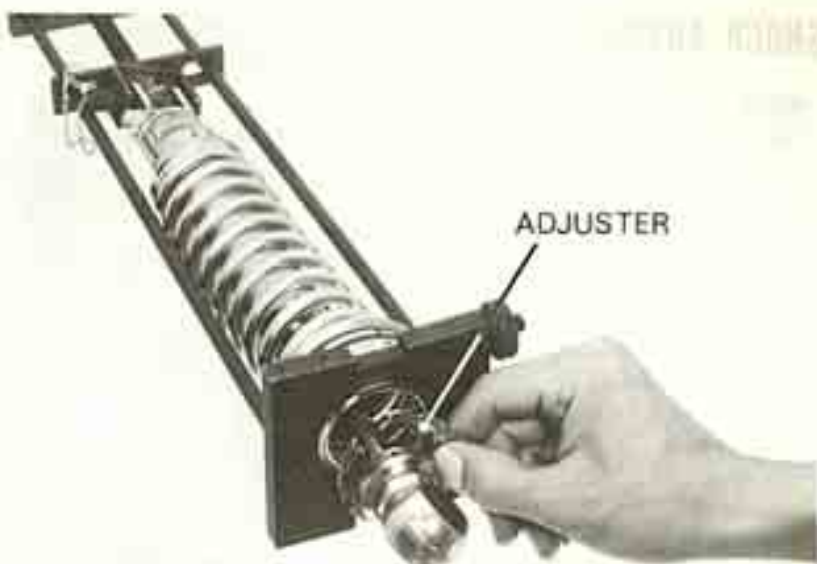

### NOTE

Do not try to disassemble the absorber any further.

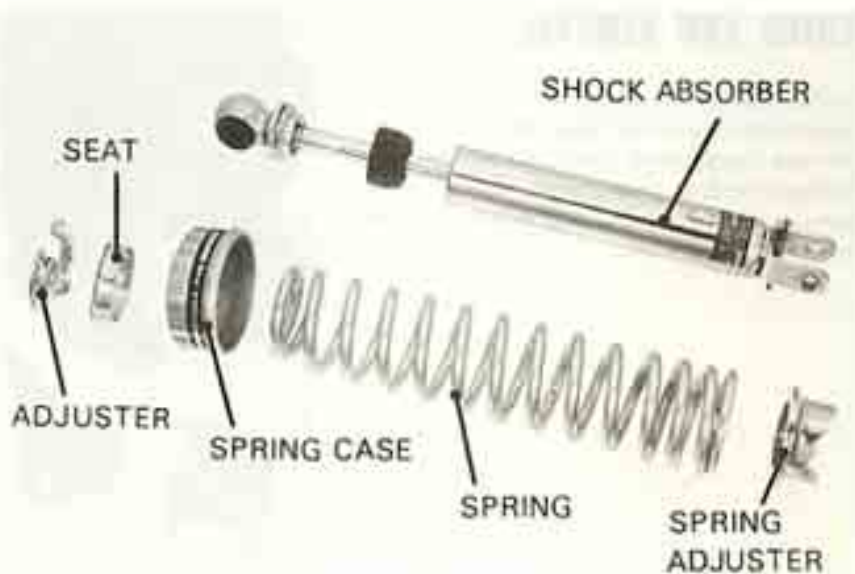

## SHOCK ABSORBER ASSEMBLY

Assembly of the shock absorber is essentially the reverse order of disassembly.

### NOTE

- Install the spring with the small coils at the bottom.
- To install the spring adjuster, use the tool "REAR SPRING COMPRESSOR" as in removal. Align the lug on the upper eye with the cutout in the adjuster.

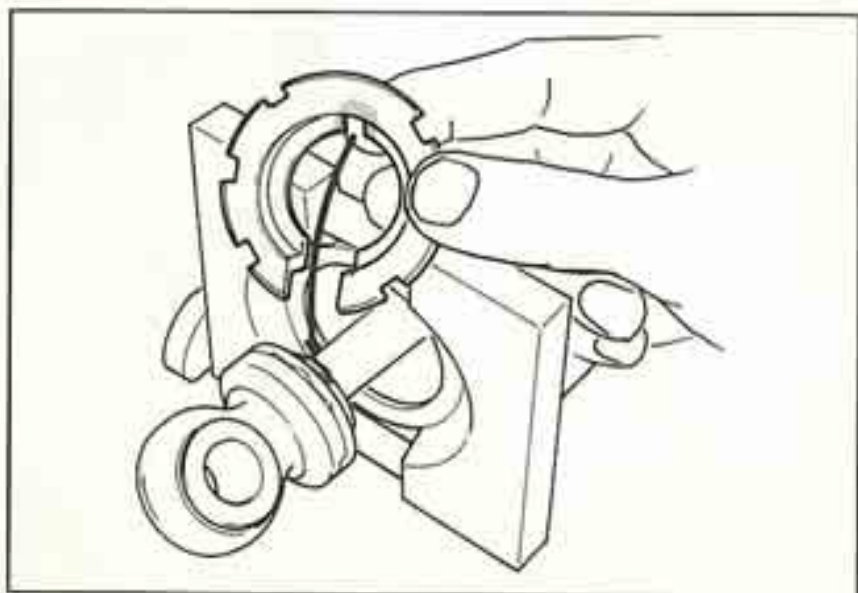



## SHOCK ABSORBER ADJUSTMENT

### NOTE

Be certain to adjust both shock absorbers to the same position.

The FVQ shock absorber has three adjustable positions; spring adjuster, damper tension adjuster and damper compression adjuster. The tension adjuster has three adjusting positions and the compression adjuster has two positions. Position "1" is for light or standard load. Position 2 kg and 3 are for heavier loads or rough roads.



## SWING ARM REMOVAL

Remove the left muffler (Page 14-3).  
Remove the rear wheel (Page 14-3).  
Remove the gearshift pedal and left foot peg.  
Remove the drive chain cover.  
Remove the right and left shock absorbers lower mounting bolts.



Remove the right muffler.  
Remove the right foot peg.  
Disconnect the rear brake master cylinder from the rear brake pedal at the joint.  
Remove the rear brake master cylinder (Page 15-14).







Loosen the rear engine hanger bolt.  
Remove the swing arm pivot bolt and move  
the left foot peg bracket out of way.  
Remove the pivot cap.



Move the right foot peg bracket out of the  
way and remove the pivot cap.  
Inspect the right pivot collar for damage.  
Replace if necessary.

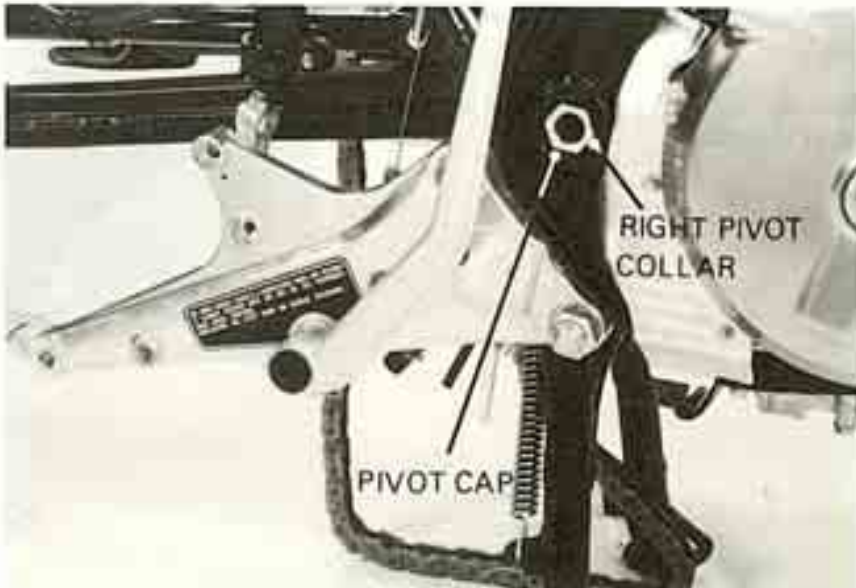

Remove the left pivot collar lock nut and  
remove the left pivot collar.  
Remove the swing arm.

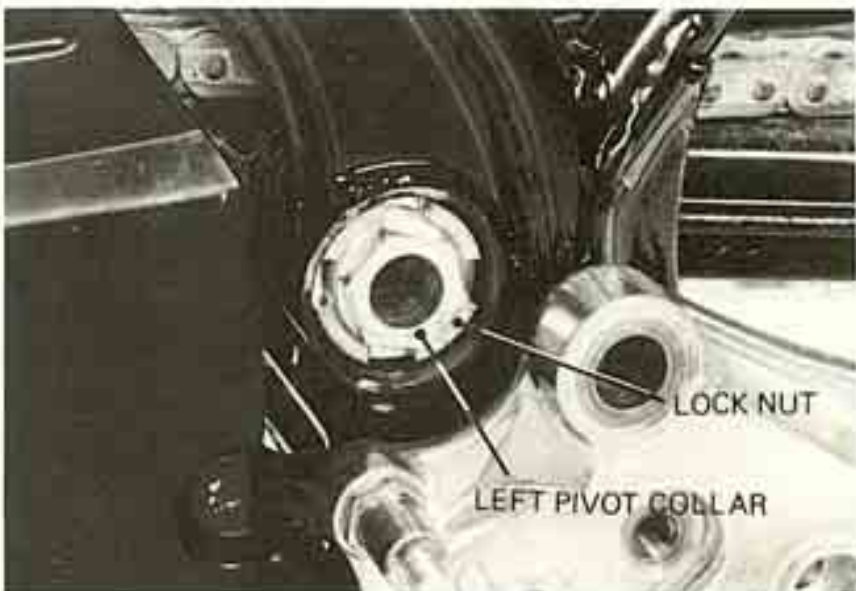





## SWING ARM DISASSEMBLY

Remove the distance collar.  
Remove the left dust seal and side collar.

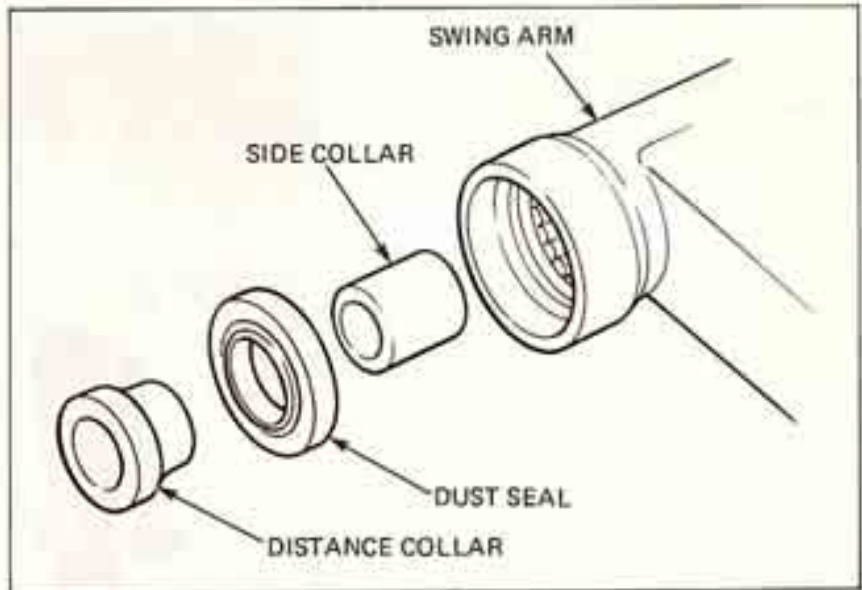

Remove the bearing retainer with the dust seal.

Remove the dust seal from the bearing retainer if necessary.



Drive out the center collar and right ball bearing as a set.





Drive out the needle bearing.

### NOTE

Replace the needle bearing with a new one whenever disassembled.



Clean all the disassembled parts and check for wear or damage. Parts which show excessive wear or damage must be replaced.

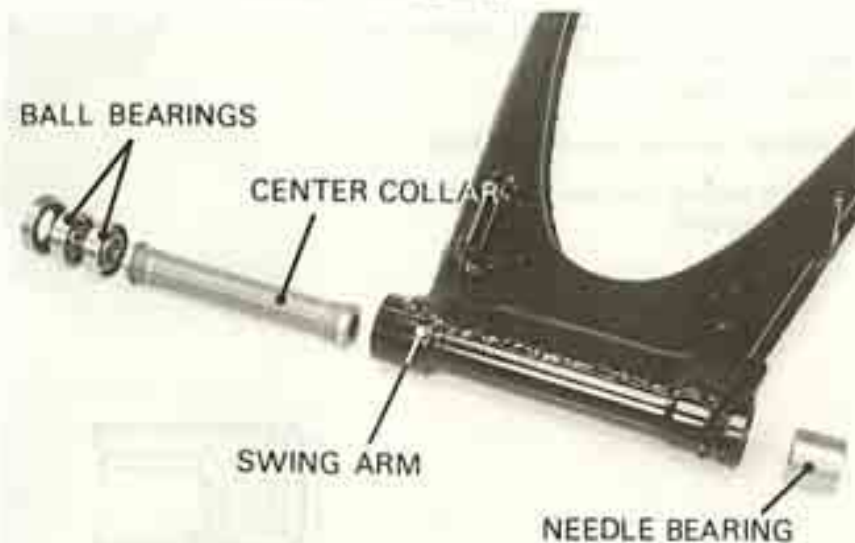

## SWING ARM ASSEMBLY

Clean all the disassembled parts.  
Pack the right bearing cavities with grease.

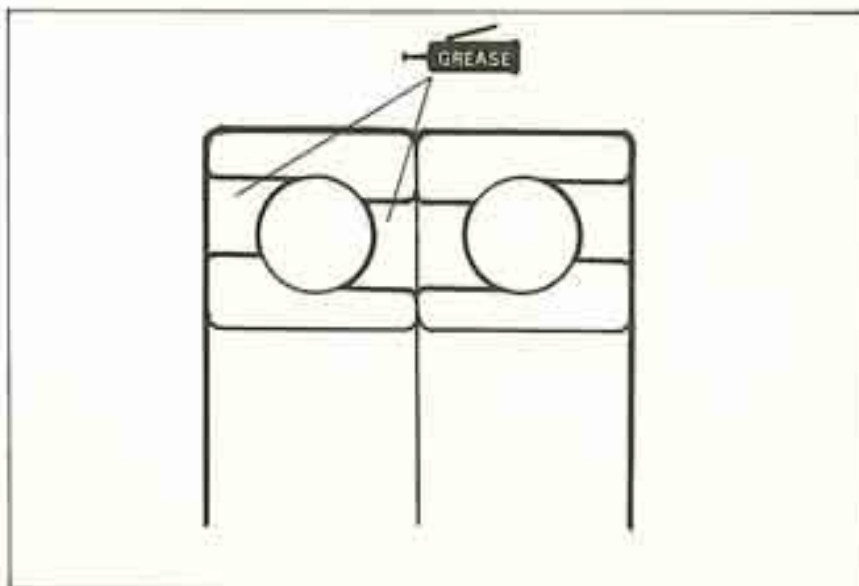



## '80 ADDENDUM

Drive one ball bearing into place with the numbers facing toward the swing arm center. Install the second ball bearing with its numbers facing out.

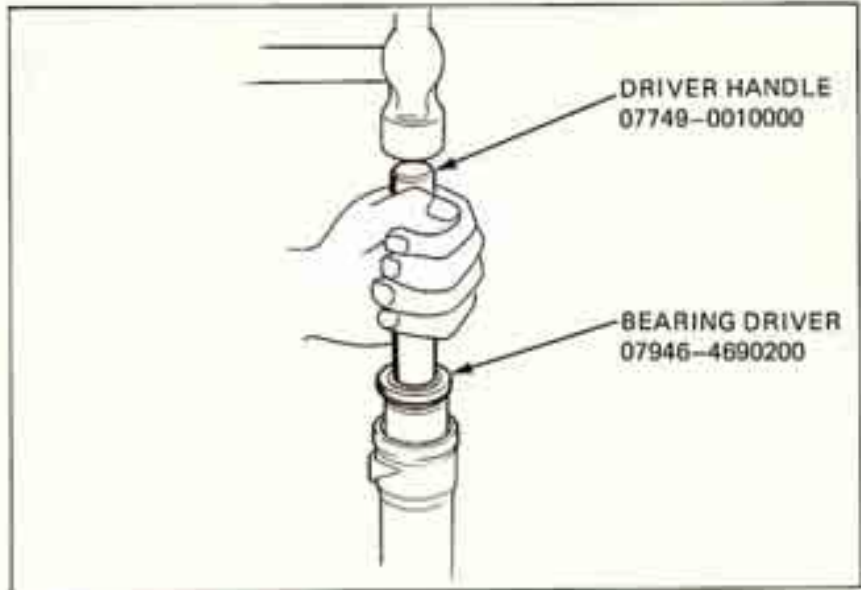

Install the dust seal onto the retainer and apply grease to the inside lip. Tighten the retainer.

**TORQUE: 3.0-4.0 kg-m (22-29 ft-lb)**

Peen the retainer over the swing arm using a hammer and drift.

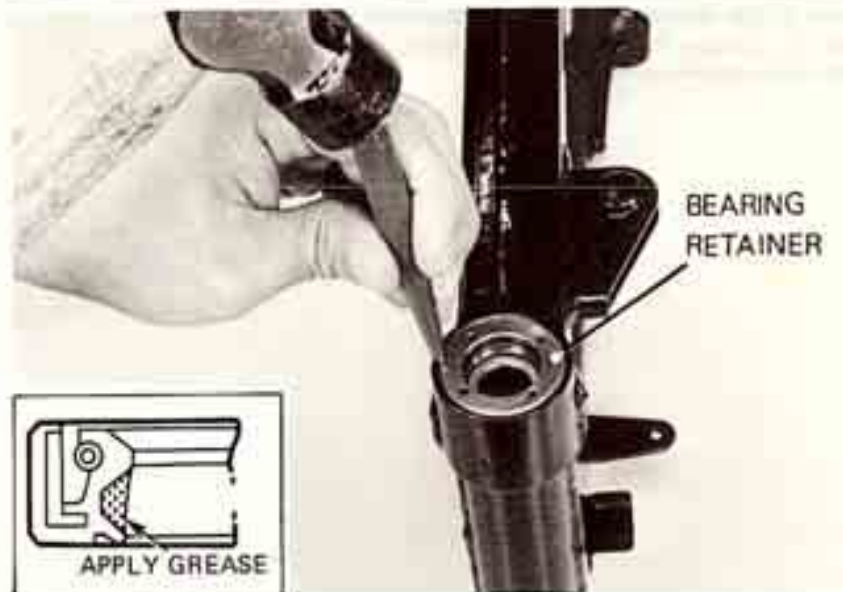

Apply grease to the center collar and slide it into place.

Pack the needle bearing with grease.

Drive the needle bearing into place with its numbers facing out.

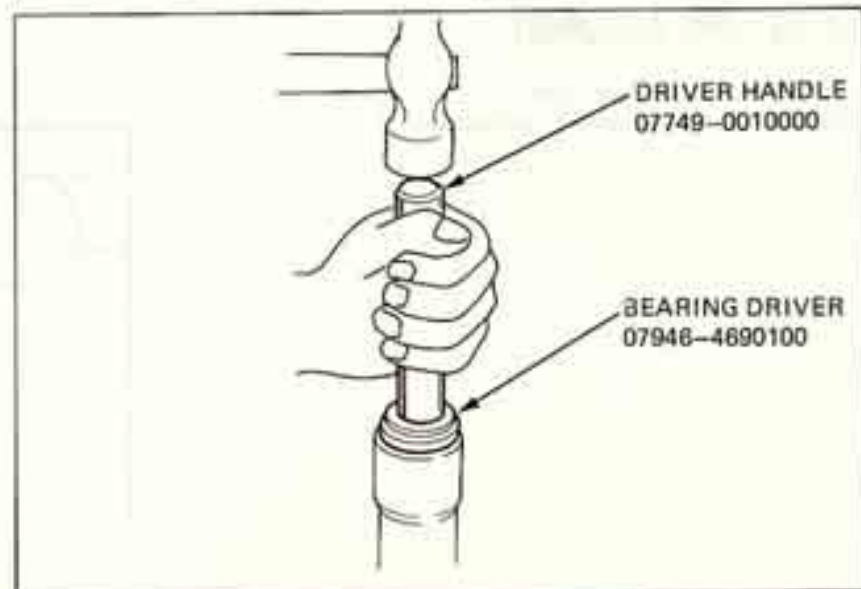





Apply grease to the dust seal; install the distance collar and dust seal on the left side.

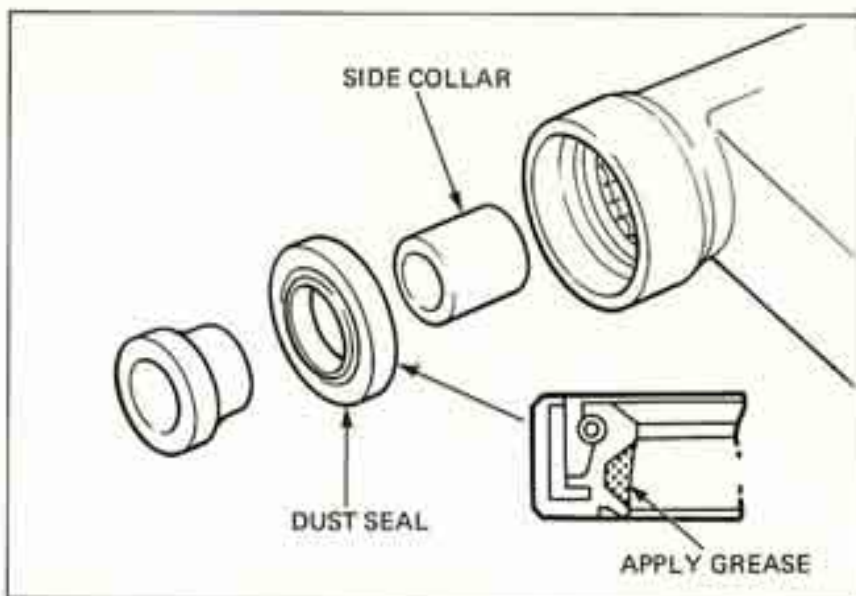

### SWING ARM INSTALLATION

Tighten the right pivot collar.

**TORQUE: 3.0-4.0 kg-m (22-29 ft-lb)**

Install the pivot cap and right foot peg bracket.



Install the distance collar onto the swing arm.  
Install the left pivot collar loosely.

**NOTE**

Make sure that the end of the pivot collar does not extend past the frame.

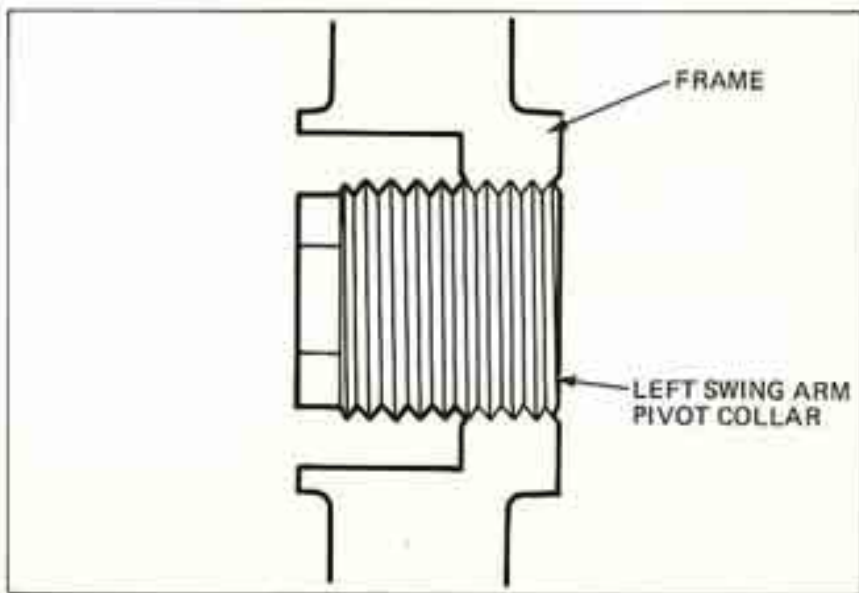



Install the swing arm and insert the pivot bolt.

Tighten the left pivot collar.

**TORQUE: 2.5–3.0 kg-m (18–22 ft-lb)**

Hold the pivot collar and tighten the lock nut.

**TORQUE: 4.5–5.5 kg-m (33–40 ft-lb)**

Install the pivot cap and left footpeg bracket.

Tighten the swing arm pivot bolt.

**TORQUE: 7.0–8.0 kg-m (51–58 ft-lb)**

Install the removed parts in the reverse order of removal.

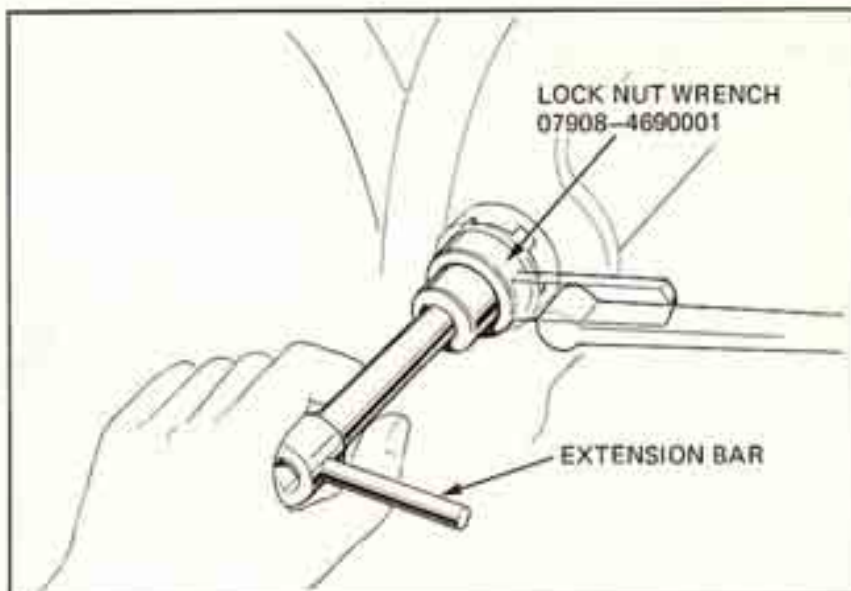

## XI. TROUBLESHOOTING

### ENGINE DOES NOT START OR IS HARD TO START

1. Check fuel flow to carburetor

↓  
REACHING CARBURETOR

NOT REACHING CARBURETOR →

- (1) Fuel tank empty
- (2) Clogged fuel tube or fuel filter
- (3) Vacuum not reaching fuel line diaphragm
- (4) Faulty fuel line diaphragm
- (5) Sticking float valve
- (6) Clogged fuel tank cap breather hole

### ENGINE LACKS POWER

4. Accelerate lightly

↓  
ENGINE SPEED INCREASE

ENGINE SPEED DOES NOT INCREASE →

- (1) Carburetor choke closed
- (2) Clogged air cleaner
- (3) Restricted fuel flow vent
- (4) Clogged fuel tank cap
- (5) Vacuum not reaching fuel line diaphragm
- (6) Fuel line diaphragm faulty
- (7) Clogged muffler

### POOR PERFORMANCE AT HIGH SPEED

2. Disconnect fuel tube

↓  
FUEL FLOWS FREELY

FUEL FLOW RESTRICTED →

- (1) Lack of fuel in tank
- (2) Clogged fuel line
- (3) Clogged fuel tank breather hole
- (4) Clogged fuel valve
- (5) Vacuum not reaching fuel line diaphragm
- (6) Fuel line diaphragm faulty



## XII. TECHNICAL FEATURES

### FRONT AIR FORKS

The front forks uses air and a coil spring. The air chamber is inside each fork tube with an air valve at the fork cap bolt.

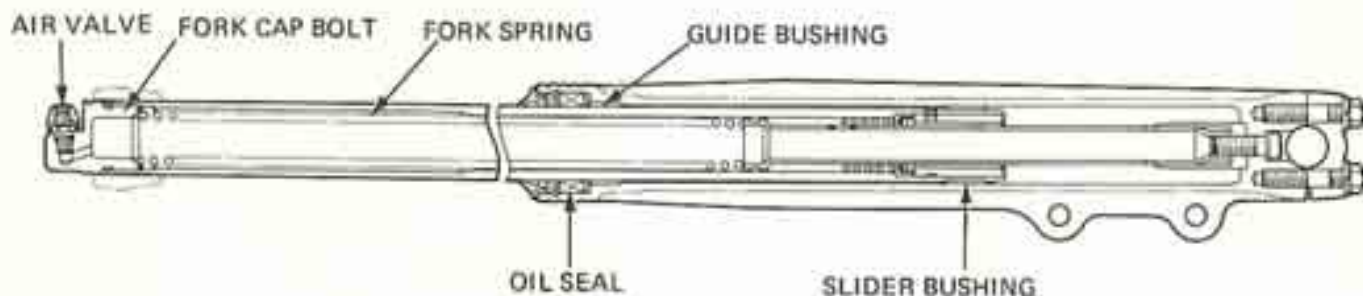

When adjusted correctly, the air fork system provides a more progressive compression than a conventional fork. The air fork system can be adjusted to each individual's preference to compensate for load and riding conditions.

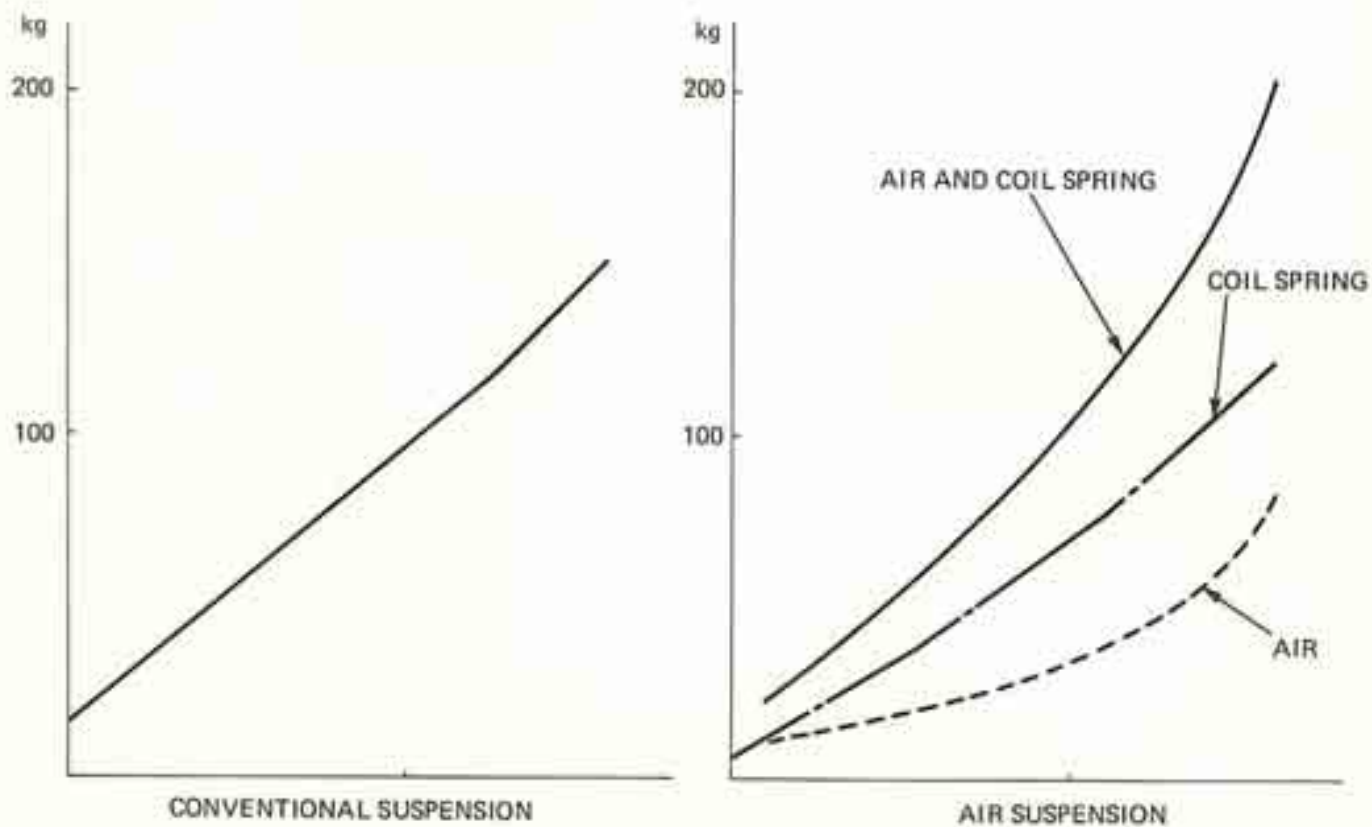





## ADJUSTABLE F.V.Q. SHOCK ABSORBER

The CBX shock absorbers have three adjustments; spring preload, compression damping and rebound damping, for each individuals preferences

### 1. Rebound Adjuster (3 stages)

The rebound adjuster consists of a plate valve with a series of orifices having different diameters. As the adjuster is moved, the valve is rotated. This changes the relationship between the orifices and piston oil passage.

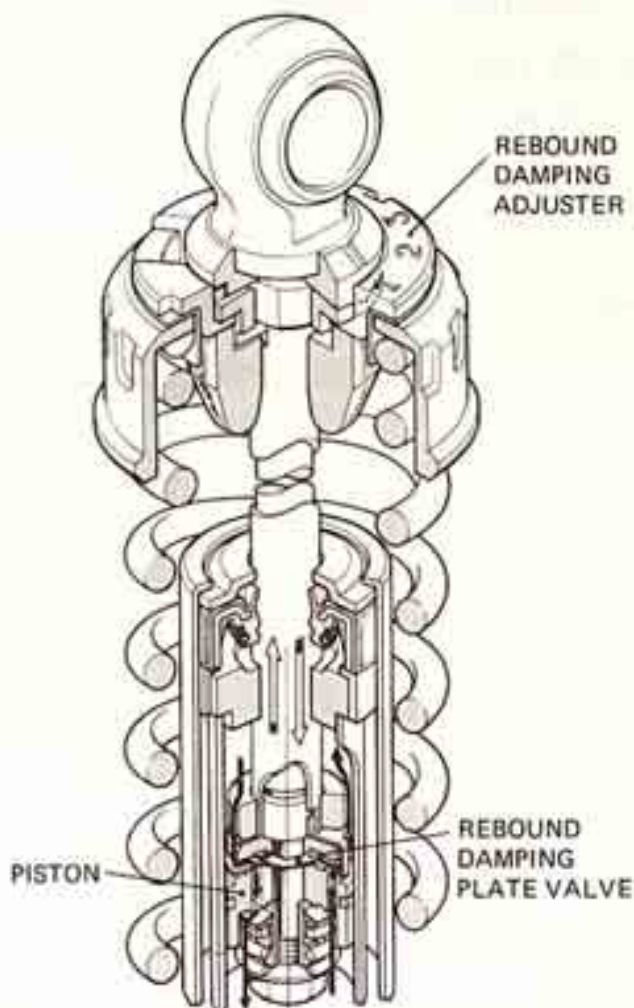

### 2. Compression Adjusting Lever (2 stages)

The compression adjuster uses a plate valve in which either of two sets of orifices with different diameters are indexed with the grooves in the bottom piece. This controls compression dampings.

### 3. Spring Preload Adjuster (5 stages)

The adjuster had 5 positions. A pin spanner is used to change the load of the shock absorber spring.

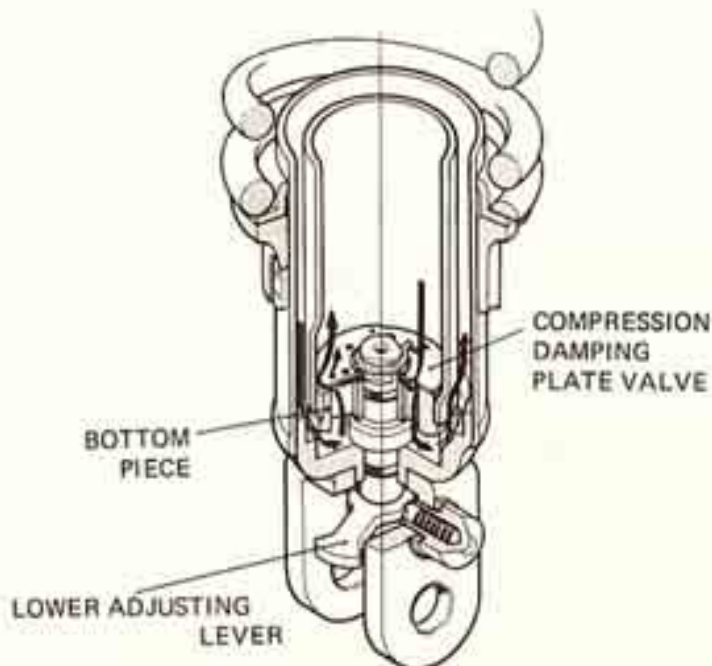



The upper adjuster controls rebound damping.



The lower adjusting mechanism controls compression.

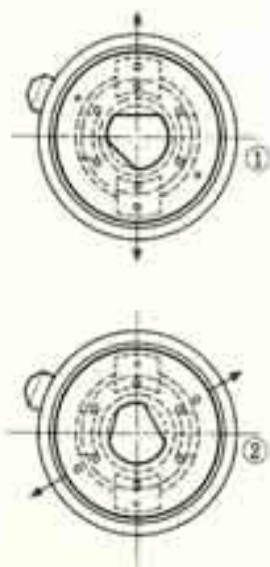

### DAMPING FORCE CHARACTERISTICS

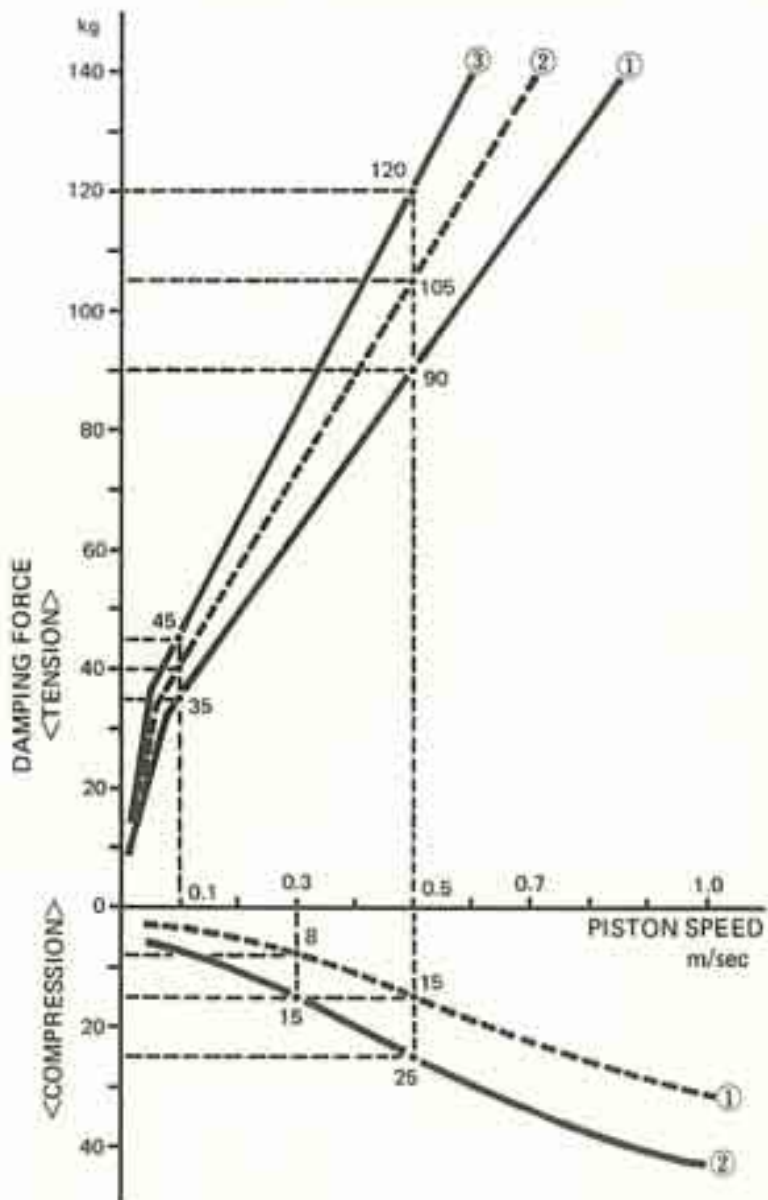



## FUEL LINE DIAPHRAGM

The fuel line diaphragm depends upon a negative crankcase pressure and a spring loaded diaphragm, allowing fuel to flow from fuel tank to the carburetor to the engine only when the engine is operating.

With the engine off the diaphragm is held against the fuel outlet within the diaphragm body; no fuel can flow through the fuel tank to the carburetor.

As the engine is cranked, negative vacuum pressure pulls the diaphragm down against diaphragm spring tension. This opens the fuel outlet allowing fuel to flow to the carburetor.

When the engine is stopped, the diaphragm is pushed back against the fuel outlet to block the fuel flow.

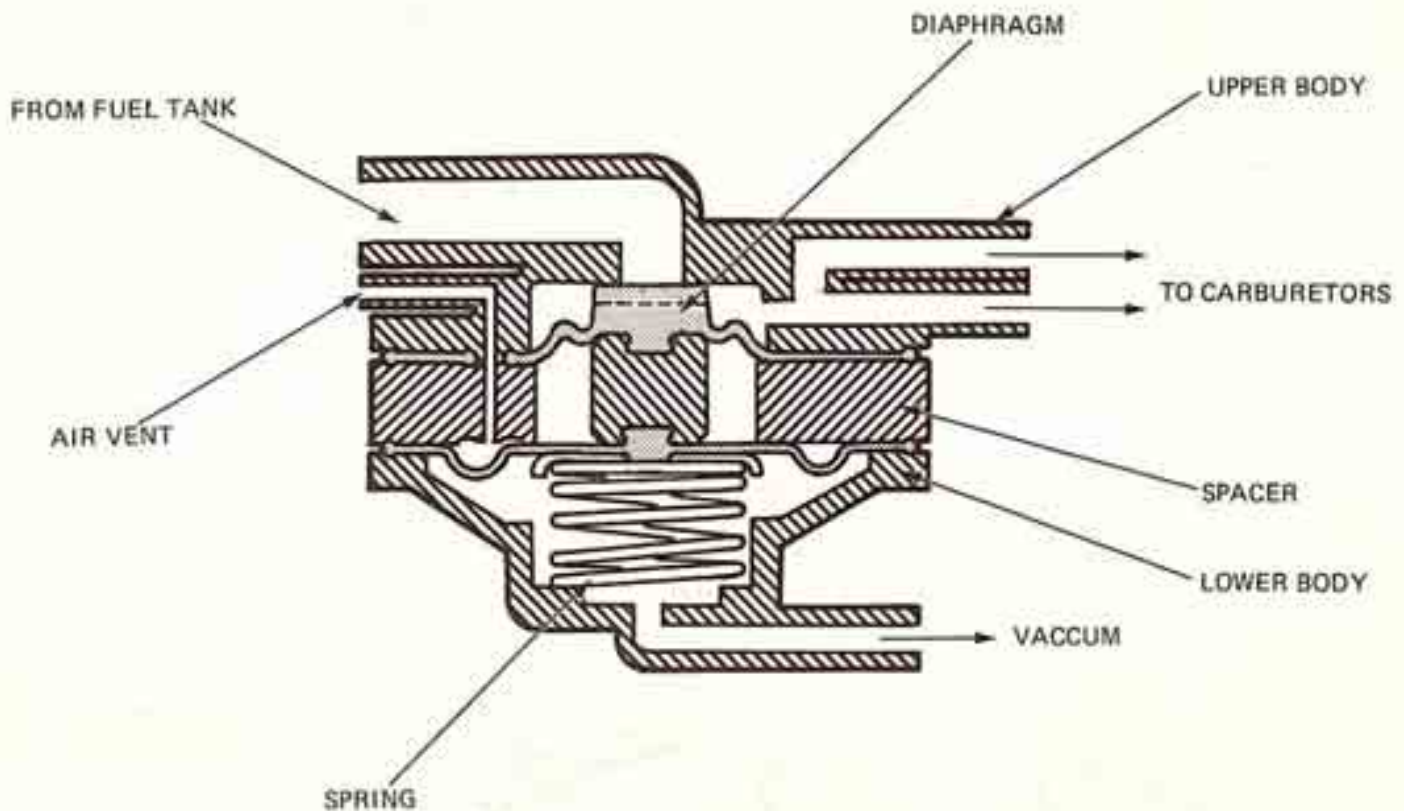





# HONDA CB X

## GENERAL INFORMATION

### WIRING DIAGRAM

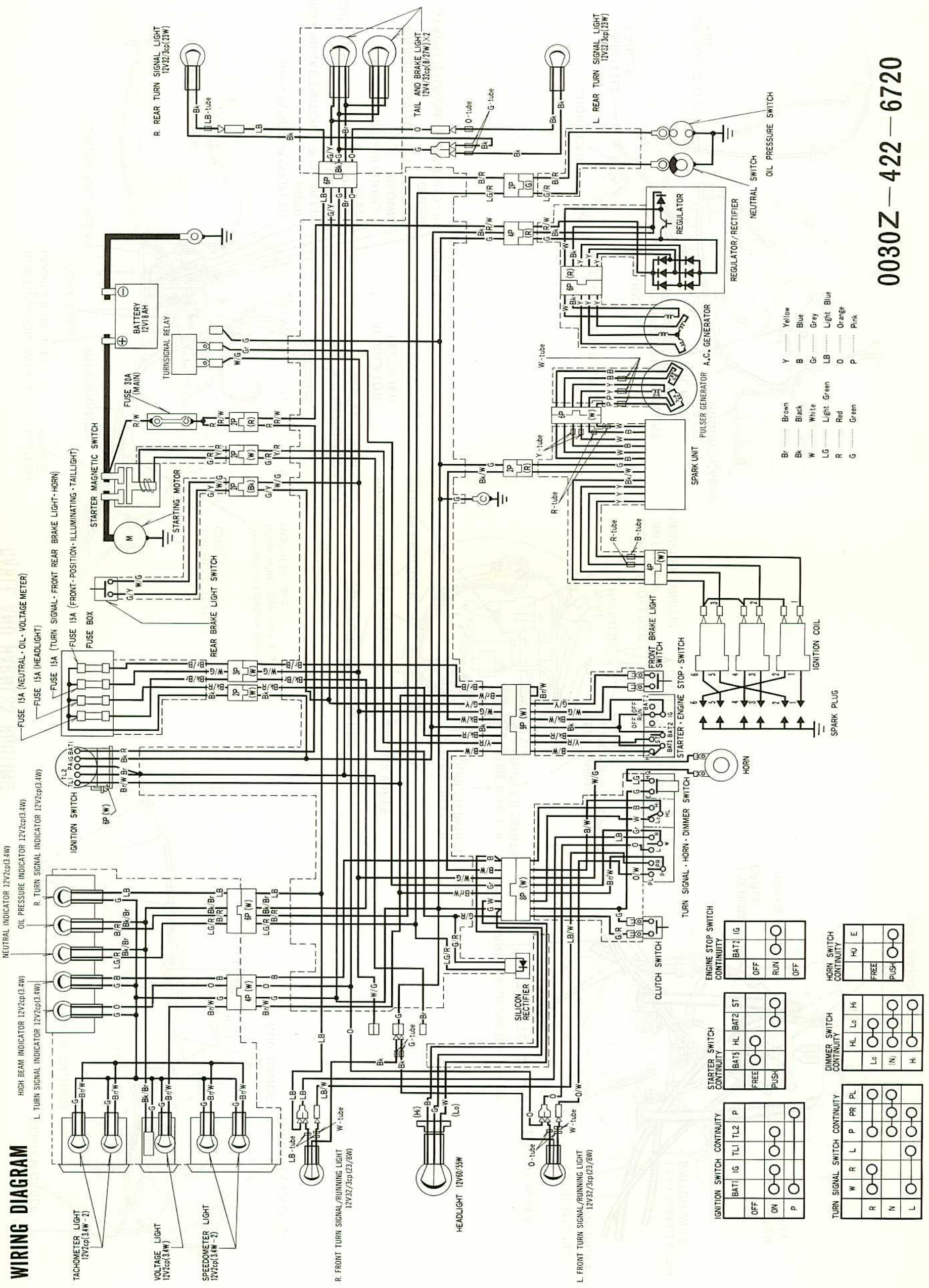

- Br ..... Brown
- Bk ..... Black
- W ..... White
- LG ..... Light Green
- R ..... Red
- G ..... Green
- Y ..... Yellow
- B ..... Blue
- Gr ..... Grey
- LB ..... Light Blue
- O ..... Orange
- P ..... Pink

0030Z-422-6720





**XIII. WIRING DIAGRAM**

**CBX**

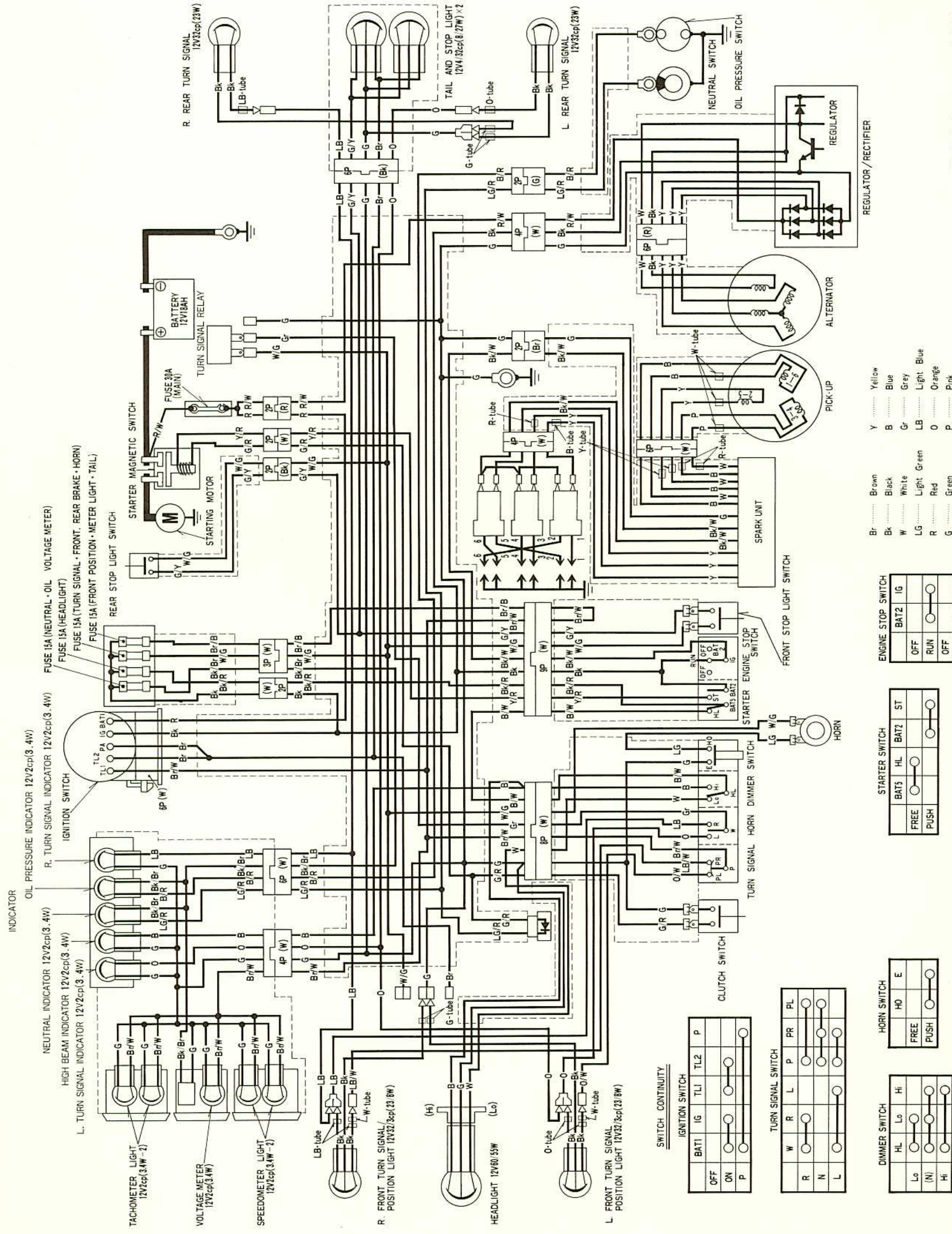

Color Legend:

Br	Brown
Bk	Black
W	White
LG	Light Green
R	Red
G	Green
Y	Yellow
B	Blue
Gr	Grey
LB	Light Blue
O	Orange
P	Pink

ENGINE STOP SWITCH

BAT2	IG
OFF	
RUN	
OFF	

STARTER SWITCH

BAT5	HL	BAT2	ST
FREE			
PUSH			

HORN SWITCH

HO	E
FREE	
PUSH	

DIMMER SWITCH

HL	Lo	Hi
Lo	(N)	Hi
FREE		
PUSH		

SWITCH CONTINUITY

BAT1	IG	TL1	TL2	P
OFF				
ON				
P				

TURN SIGNAL SWITCH

W	R	L	P	PR	PL
R					
N					
L					



