

# YASKAWA AC Drive - A1000

## Motion Control

## Custom Software Supplement

Software Number: VSA91007□

Type: CIMR-AU□A□□□□

Models: 200 V Class: 0004-0415

400 V Class: 0002-0675

600 V Class: 0003-0242

To properly use the product, read this manual thoroughly and retain for easy reference, inspection, and maintenance. Ensure the end user receives this manual.

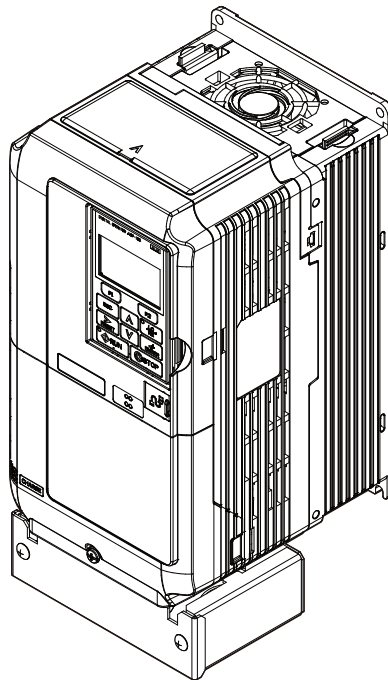



# Table of Contents

---

<b>1</b>	<b>PREFACE AND SAFETY</b> .....	<b>5</b>
<b>2</b>	<b>PRODUCT OVERVIEW</b> .....	<b>6</b>
<b>3</b>	<b>MODIFICATIONS</b> .....	<b>7</b>
<b>4</b>	<b>RELATED PARAMETERS AND FUNCTIONS</b> .....	<b>8</b>
<b>6</b>	<b>ABSOLUTE ENCODER SPECIFICATIONS</b> .....	<b>39</b>

Refer to the A1000 Technical Manual for content not described in this document.

Copyright © 2013 YASKAWA AMERICA, INC.

All rights reserved. No part of this publication may be reproduced, stored in a retrieval system, or transmitted, in any form or by any means, mechanical, electronic, photocopying, recording, or otherwise, without the prior written permission of Yaskawa. No patent liability is assumed with respect to the use of the information contained herein. Moreover, because Yaskawa is constantly striving to improve its high-quality products, the information contained in this manual is subject to change without notice. Every precaution has been taken in the preparation of this manual. Yaskawa assumes no responsibility for errors or omissions. Neither is any liability assumed for damages resulting from the use of the information contained in this publication.

---

**This Page Intentionally Blank**

# 1 Preface and Safety

Yaskawa manufactures products used as components in a wide variety of industrial systems and equipment. The selection and application of Yaskawa products remain the responsibility of the equipment manufacturer or end user. Yaskawa accepts no responsibility for the way its products are incorporated into the final system design. Under no circumstances should any Yaskawa product be incorporated into any product or design as the exclusive or sole safety control. Without exception, all controls should be designed to detect faults dynamically and fail safely under all circumstances. All systems or equipment designed to incorporate a product manufactured by Yaskawa must be supplied to the end user with appropriate warnings and instructions as to the safe use and operation of that part. Any warnings provided by Yaskawa must be promptly provided to the end user. Yaskawa offers an express warranty only as to the quality of its products in conforming to standards and specifications published in the Yaskawa manual. **NO OTHER WARRANTY, EXPRESS OR IMPLIED, IS OFFERED.** Yaskawa assumes no liability for any personal injury, property damage, losses, or claims arising from misapplication of its products

## ◆ Applicable Documentation

The following manuals are available for the A1000 Drive:

### Yaskawa Drive

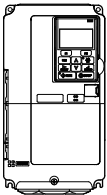
	<b>Yaskawa AC Drive - A1000 Quick Start Guide</b>	To obtain instruction manuals for Yaskawa products access these sites: U.S.: <a href="http://www.yaskawa.com">http://www.yaskawa.com</a> Europe: <a href="http://www.yaskawa.eu.com">http://www.yaskawa.eu.com</a> Japan: <a href="http://www.e-mechatronics.com">http://www.e-mechatronics.com</a> Other areas: contact a Yaskawa representative. For questions, contact the local Yaskawa sales office or the nearest Yaskawa representative.
	<b>Yaskawa AC Drive - A1000 Technical Manual</b>	

## ◆ Supplemental Safety Information

Read and understand this manual and the A1000 Quick Start Guide before installing, operating, or servicing this option unit. Install the drive according to the A1000 Quick Start Guide and local codes. Observe all cautions and warnings in this document and the standard drive technical manuals.

Refer to the A1000 Quick Start Guide and Technical Manual for safety information and to install and start-up the drive.

This document is a supplement to the standard drive technical manual. It describes the effects on the drive parameters and functions with the software installed.

- Custom software is provided to add functionality to a standard drive to enhance or enable use in a specific application.
- The software is loaded to the flash ROM area of the control board, and replaces the standard drive software.

## ◆ Obtaining Support

When seeking support for a drive with custom software, it is imperative to provide the unique part number shown on the drive nameplate. The software is flashed to the control board memory and the operation of parameters, functions, and monitors are different than the standard drive software, as described herein.

Refer to Yaskawa office locations listed on the back cover of this manual.

# 2 Product Overview

---

### ◆ About this Product

This custom software is designed for A1000 drives to provide simple position control capability. The software does this by internally taking control of the drive's frequency reference.

---

### ◆ Applicable Models

This custom operation software is available for the A1000 drive models shown in [Table 1](#).

**Table 1 Applicable Models**

Voltage Class	Models CIMR-AU	Software Version <1>
200 V Three-Phase	2A0004 to 2A0415	VSA91007□
400 V Three-Phase	4A0002 to 4A0675	
600 V Three-Phase	4A0003 to 4A0242	

<1> See "PRG" on the drive nameplate for the software version number.

## 3 Modifications

### ◆ Changes from Standard Software

- 3-Wire control is not allowed when the motion software is enabled.
- Parameter b1-01 (Reference Source) is only effective when motion control is disabled (P1-01 = 0). When motion control is enabled, parameter b1-01 is ignored, and the frequency reference originates from the motion control routine.
- Parameters d2-02 and d2-03 are disabled, which fixes the minimum output speed at 0 %.
- Accel and Decel ramp switching via multifunction digital input or via speed sensing is disabled when a move is in progress. Accel and Decel ramp switch is controlled by the motion software during a move.

### ◆ Limitations

- The Motion Control algorithm is only available when the drive is in the Flux Vector control method (A1-02 =3).
- Motion control functionality is disabled when the drive is in Local mode or b1-02 = 0.
- The distance from home cannot exceed  $10^9$  encoder counts.
- The 32 bit position monitor registers should be read using a Read Multiple Memobus command (03h) to ensure that the data from high and low words are read together for an accurate reporting of position.
- Using the 32 bit position command, the drive can now operate in a position beyond what the digital operator can display.
- The drive must be re-homed after a PG Open (PGo) fault occurs.
- The maximum number of DWEZ connections has been reduced to 50 connections.

## 4 Related Parameters and Functions

### ◆ Control Modes, Symbols and Terms

The table below lists terms and symbols used in this section to indicate which parameters are available in which control modes.

	Description
<b>All Modes</b>	Parameter is available in all control modes.
<b>V/f</b>	Parameter is available when operating the drive with V/f Control.
<b>V/f w PG</b>	Parameter is available when operating the drive with V/f with PG Control.
<b>OLV</b>	Parameter is available when operating the drive with Open Loop Vector.
<b>CLV</b>	Parameter is available when operating the drive with Closed Loop Vector.
<b>OLV/PM</b>	Parameter is available when operating the drive with Open Loop Vector for PM monitors.
<b>AOLV/PM</b>	Parameter is available when operating the drive with Advanced Open Loop Vector for PM monitors.
<b>CLV/PM</b>	Parameter is available when operating the drive with Closed Loop Vector for PM monitors.

### ◆ Additional Parameters and Modified Parameters

#### ■ Additional Parameters

The parameters in [Table 2](#) are used to set up the drive for operation with the software. Parameters are available in the control modes shown in the Description column. The only valid Control Mode Access Level for the listed parameters in [Table 2](#) is CLV (Closed Loop Vector).

**Table 2 Additional Parameters**



















No. (Addr. Hex)	Parameter Name Digital Operator Display	Description	Values	Change During Run	Control Mode Access Level
P1-01 (600h)	Motion Type <b>Motion Type</b>	0: Disabled 1: Linear Absolute 2: Rotary Absolute 3: Relative Mem Off 4: Relative Mem On	Default: 0 Range: 0 to 4	No	<b>CLV</b>
P1-02 (601h)	Distance Select <b>Distance Select</b>	0: Preset P4-□ □ 1: Modbus 16 Bit (06D0h and 06D1h) <-> 2: Option Card Hi-Speed Option Card Frequency Reference Register <-> A multifunction input selection of Distance Select will override this parameter. 3: Modbus 32-Bit (06D0h and 06D1h) <->	Default: 0 Range: 0 to 3	No	<b>CLV</b>
P1-03 (602h)	Move Command Type <b>Move CMD. Type</b>	0: Maintained-Move command must be maintained for the entire move. 1: Rising Edge-Move command is edge-triggered. 2: Falling Edge-Move command is edge-triggered.	Default: 0 Range: 0 to 2	No	<b>CLV</b>
P1-04 (603h)	Positioning proportional Gain <b>Pos P Gain</b>	Proportional gain used for the position controller.	Default: 1.0 Range: 1.0 to 20.0	Yes	<b>CLV</b>



## 4 Related Parameters and Functions

No. (Addr. Hex)	Parameter Name Digital Operator Display	Description	Values	Change During Run	Control Mode Access Level
P1-05 (604h)	Decel Start Compensation Distance <b>Decel Comp Dist</b>	Starts the deceleration ramp early. Increase if there is over shoot. Decrease if there is undershoot.	Default: 0 Range: 0 to 65535 cts	Yes	<b>CLV</b>
P1-06 (605h)	Positioning Speed Compensation <b>Pos Spd Comp</b>	Provides fine adjustment for the automatically calculated positioning speed.	Default: 100 % Range: 10.0 to 200.0 %	Yes	<b>CLV</b>
P1-07 (606h)	Triangle Move Compensation <b>Trig Move Comp</b>	Determines response for a triangular move. Increase if overshooting. Decrease if undershooting when performing a triangle move instead of a trapezoid move.	Default: 1.0 Range: 0.0 to 100.0	Yes	<b>CLV</b>
P1-08 (607h)	In Position Window <b>In Posit. Window</b>	Controls when the Move Complete digital output turns on. Also determines when another edge-triggered move will be accepted.	Default: 200 Range: 0 to 65535 cts	Yes	<b>CLV</b>
P1-09 (608h)	Counts Per Unit <b>Counts per Unit</b>	This parameter is multiplied by the distance command in order to determine move length in counts.	Default: 4096 Range: 0 to 65535 cts	No	<b>CLV</b>
P1-10 (609h)	Distance Display Units <b>Distance Units</b>	0: None 1: Inches (in) 2: Feet (ft) 3: Centimeters (cm) 4: Meters (m) 5: Degrees (°) 6: Revolutions (rev)	Default: 1 Range: 0 to 6	No	<b>CLV</b>
P2-01 (60Ah)	Homing Type <b>Homing Type &lt;-&gt;</b>	0: Home Negative 1: Home Neg w/BU 2: Home Positive 3: Home Pos w/BU 4: Negative w/mark 5: Positive w/mark 6: Manual	Default: 0 Range: 0 to 6	No	<b>CLV</b>
P2-02 (60Bh)	Homing Speed <b>Homing Speed</b>	Speed reference during course homing.	Default: 10.0 Hz Range: 0.0 to 400.0 Hz	Yes	<b>CLV</b>
P2-03 (60Ch)	Homing Back-Up Speed <b>Homing BU Speed</b>	Speed reference used during the back-up portion of the homing routine.	Default: 2.0 Hz Range: 0.0 to 20.0 Hz	Yes	<b>CLV</b>
P2-04 (60Dh)	Homing Final Speed <b>Homing Final Spd</b>	Speed reference used during the final portion of the homing routine.	Default: 1.0 Hz Range: 0.0 to 20.0 Hz	Yes	<b>CLV</b>
P2-05 (60Eh)	Switch Type <b>Switch Type</b>	Sets the normal (not activated) state of the home and over-travel limit switches. 0: Both NO 1: OT NO Home NC 2: OT NC Home NO 3: Both NC	Default: 0 Range: 0 to 3	No	<b>CLV</b>
P2-06 (60Fh)	Home Offset Distance <b>Home Offset Dist</b>	Distance from the home limit switch that is considered home.	Default: 0.00 Range: -99 to 99.99 Units <->	No	<b>CLV</b>
P2-08 (611h)	Pre-Action Distance <b>Pre Act Dist</b>	During a move, when the machine is the distance from the destination, a digital output (H2-0□=46) will activate until the In Position window is reached.	Default: 0.00 Range: 0.00 to 500.00 Units <->	Yes	<b>CLV</b>
P3-01 (614h)	Position Encoder Source <b>Encoder Source</b>	0: PG-X3 CH-1 - PG-X3 or PG-B3 (CN5-C) 1: PG-X3 CH-2 - PG-X3 or PG-B3 (CN5-B) 2: Abs Gray Encoder- Absolute Gray Code (connected via DI-A3) <-6> 3: TR Encoder CH1 3: TR Encoder CH2	Default: 0 Range: 0 to 4	No	<b>CLV</b>

## 4 Related Parameters and Functions

No. (Addr. Hex)	Parameter Name Digital Operator Display	Description	Values	Change During Run	Control Mode Access Level
P3-02 (615h)	Positioning Encoder Pulses Per Revolution <b>2nd Encoder PPR</b>	Encoder pulses per revolution when P3-01=1. Encoder counts per revolution when p1-01=2 <math>\leftrightarrow</math>	Default: 1024 Range: 60 to 100000 PPR	No	
P3-03 (616h)	Positioning Encoder Numerator <b>2nd Encoder NUM</b>	Machine-mounted encoder ration numerator. Used in conjunction with P3-04. Effective only when a 2 <sup>nd</sup> machine-mounted encoder is used.	Default: 1 Range: 1 to 65535	No	
P3-04 (617h)	Positioning Encoder Denominator <b>2nd Encoder DEN</b>	Machine-mounted encoder ration denominator. Used in conjunction with P3-03. Effective only when a 2 <sup>nd</sup> machine-mounted encoder is used.	Default: 1 Range: 1 to 65535	No	
P3-07 (61Ah)	Length of One Rotation (Encoder Revolutions) <b>Len 1 Rotate REV</b>	Sets the distance of one complete revolution of the rotary machine. Effective only when P1-01=2. One Rotation (counts)=(P3-07 $\times$ F1-01 <math>\leftrightarrow</math> $\times$ 4) + P3-08	Default: 0 Range: 0 to 9999 Rev	No	
P3-08 (61Bh)	Length of One Rotation (Encoder Counts) <b>Len 1 Rotate CTS</b>	Sets the distance of one complete revolution of the rotary machine. Effective only when P1-01=2. One Rotation (counts)=(P3-07 $\times$ F1-01 <math>\leftrightarrow</math> $\times$ 4) + P3-08	Default: 0 Range: 0 to 40000 cts	No	
P4-01 (620h)	Position 1 <b>Position 1</b>	Position Reference in units. Position Ref. (counts)=P4-01 $\times$ P1-09	Default: 0.00 Range: 655.35 Units <math>\leftrightarrow</math>	Yes	
P4-02 (621h)	Position 2 <b>Position 2</b>	Position Reference in units. Position Ref. (counts)=P4-02 $\times$ P1-09	Default: 0.00 Range: 655.35 Units <math>\leftrightarrow</math>	Yes	
P4-03 (622h)	Position 3 <b>Position 3</b>	Position Reference in units. Position Ref. (counts)=P4-03 $\times$ P1-09	Default: 0.00 Range: 655.35 Units <math>\leftrightarrow</math>	Yes	
P4-04 (623h)	Position 4 <b>Position 4</b>	Position Reference in units. Position Ref. (counts)=P4-04 $\times$ P1-09	Default: 0.00 Range: 655.35 Units <math>\leftrightarrow</math>	Yes	
P4-05 (624h)	Position 5 <b>Position 5</b>	Position Reference in units. Position Ref. (counts)=P4-05 $\times$ P1-09	Default: 0.00 Range: 655.35 Units <math>\leftrightarrow</math>	Yes	
P4-06 (625h)	Position 6 <b>Position 6</b>	Position Reference in units. Position Ref. (counts)=P4-06 $\times$ P1-09	Default: 0.00 Range: 655.35 Units <math>\leftrightarrow</math>	Yes	
P4-07 (626h)	Position 7 <b>Position 7</b>	Position Reference in units. Position Ref. (counts)=P4-07 $\times$ P1-09	Default: 0.00 Range: 655.35 Units <math>\leftrightarrow</math>	Yes	
P4-08 (627h)	Position 8 <b>Position 8</b>	Position Reference in units. Position Ref. (counts)=P4-08 $\times$ P1-09	Default: 0.00 Range: 655.35 Units <math>\leftrightarrow</math>	Yes	
P4-09 (628h)	Position 9 <b>Position 9</b>	Position Reference in units. Position Ref. (counts)=P4-09 $\times$ P1-09	Default: 0.00 Range: 655.35 Units <math>\leftrightarrow</math>	Yes	
P4-10 (629h)	Position 10 <b>Position 10</b>	Position Reference in units. Position Ref. (counts)=P4-10 $\times$ P1-09	Default: 0.00 Range: 655.35 Units <math>\leftrightarrow</math>	Yes	
P4-11 (62Ah)	Position 11 <b>Position 11</b>	Position Reference in units. Position Ref. (counts)=P4-11 $\times$ P1-09	Default: 0.00 Range: 655.35 Units <math>\leftrightarrow</math>	Yes	
P4-12 (62Bh)	Position 12 <b>Position 12</b>	Position Reference in units. Position Ref. (counts)=P4-12 $\times$ P1-09	Default: 0.00 Range: 655.35 Units <math>\leftrightarrow</math>	Yes	
P4-13 (62Ch)	Position 13 <b>Position 13</b>	Position Reference in units. Position Ref. (counts)=P4-13 $\times$ P1-09	Default: 0.00 Range: 655.35 Units <math>\leftrightarrow</math>	Yes	

No. (Addr. Hex)	Parameter Name Digital Operator Display	Description	Values	Change During Run	Control Mode Access Level
P4-14 (62Dh)	Position 14 <b>Position 14</b>	Position Reference in units. Position Ref. (counts)=P4-14 × P1-09	Default: 0.00 Range: 655.35 Units </>	Yes	<b>CLV</b>
P4-15 (62Eh)	Position 15 <b>Position 15</b>	Position Reference in units. Position Ref. (counts)=P4-15 × P1-09	Default: 0.00 Range: 655.35 Units </>	Yes	<b>CLV</b>
P4-16 (62Fh)	Position 16 <b>Position 16</b>	Position Reference in units. Position Ref. (counts)=P4-16 × P1-09	Default: 0.00 Range: 655.35 Units </>	Yes	<b>CLV</b>

<1> The actual command destination is calculated as follows when P1-02=3: Destination=Memobus register 6D1h × P1-09/100.

<2> Actual destination (in encoder quadrature counts) is calculated as follows:

$$\text{Destination} = \frac{\text{Frequency Reference (hi-speed register)}}{100} \times \text{P1-09}$$

<3> The actual commanded destination is the combined value of Memobus registers 6D0h (low word) and 6D1h (high word) when P1-02 = 3. Parameter P1-09 has no effect as this is strictly a command in encoder quadrature counts. Speed for this profile is set by d1-01, the acceleration time is set by C1-01, and the deceleration time is set by C1-02.

<4> The units text displayed in the digital operator are determined by parameter P1-10. Actual destination in encoder counts is calculated by multiplying the preset position reference by P1-09.

<5> When parameter P3-01=3 or 4 (encoder type = absolute incremental), the Homing Type (P2-01) parameter has no effect. The drive is base-blocked and then the position is read from the encoder via the PG-X3 card installed in CN5-B when a home command is issued. This will only happen if the drive does not have a run command.

<6> The position reference is lower-limited to 0 counts and upper-limited to 262143 counts with a Gray Encoder.

<7> Parameter F1-31 is ignored by the Motion Control software. It uses parameter P3-02 instead.

<8> If P3-01 = 1, then parameter P3-02 is used in place of parameter F1-01 when determining actual distance.

## ■ Modified Parameters

Table 3 Modified Parameters

No. (Addr. Hex)	Parameter Name Digital Operator Display	Description	Values	Change During Run	Control Mode Access Level
C1-01 (200h)	Acceleration Time 1 <b>Accel Time 1</b>	Sets the time to accelerate from 0 to maximum frequency.	Default: 2.0 s Range: 0.0 to 6000.0 s </>	Yes	<b>All Modes</b>
C1-02 (201h)	Deceleration Time 1 <b>Decel Time 1</b>	Sets the time to decelerate from maximum frequency to 0.	Default: 2.0 s Range: 0.0 to 6000.0 s </>	Yes	<b>All Modes</b>
C1-03 (202h)	Acceleration Time 2 <b>Accel Time 2</b>	Sets the time to accelerate from 0 to maximum frequency.	Default: 2.0 s Range: 0.0 to 6000.0 s </>	No	<b>All Modes</b>
C1-04 (203h)	Deceleration Time 2 <b>Decel Time 2</b>	Sets the time to decelerate from maximum frequency to 0.	Default: 2.0 s Range: 0.0 to 6000.0 s </>	Yes	<b>All Modes</b>
C1-05 (204h)	Acceleration Time 3 (Motor 2 Accel Time 1) <b>Accel Time 3</b>	Sets the time to accelerate from 0 to maximum frequency during Motor 2 operation.	Default: 2.0 s Range: 0.0 to 6000.0 s </>	Yes	<b>All Modes</b>
C1-06 (205h)	Deceleration Time 3 (Motor 2 Decel Time 1) <b>Decel Time 3</b>	Sets the time to decelerate from maximum frequency to 0 during Motor 2 operation.	Default: 2.0 s Range: 0.0 to 6000.0 s </>	Yes	<b>All Modes</b>
C1-07 (206h)	Acceleration Time 4 (Motor 2 Accel Time 2) <b>Accel Time 4</b>	Sets the time to accelerate from 0 to maximum frequency during Motor 2 operation.	Default: 2.0 s Range: 0.0 to 6000.0 s </>	Yes	<b>All Modes</b>
C1-08 (207h)	Deceleration Time 4 (Motor 2 Decel Time 2) <b>Decel Time 4</b>	Sets the time to decelerate from maximum frequency to 0 during Motor 2 operation.	Default: 2.0 s Range: 0.0 to 6000.0 s </>	Yes	<b>All Modes</b>

## 4 Related Parameters and Functions

No. (Addr. Hex)	Parameter Name Digital Operator Display	Description	Values	Change During Run	Control Mode Access Level
C2-01 (20Bh)	S-Curve Characteristic at Accel Start <b>SCrv Acc @ Start</b>	Sets the S-Curve characteristic at the start of acceleration.	Default: 0.00 s <> Range: 0.00 to 10.00 s	No	All Modes
C2-02 (20Ch)	S-Curve Characteristic at Accel End <b>SCrv Acc @ End</b>	Sets the S-Curve characteristic at the end of acceleration.	Default: 0.00 s Range: 0.00 to 10.00 s	No	All Modes
C2-03 (20Dh)	S-Curve Characteristic at Decel Start <b>SCrv Dec @ Start</b>	Sets the S-Curve characteristic at the start of deceleration.	Default: 0.00 s Range: 0.00 to 10.00 s	No	All Modes
d1-09 (288h)	Frequency Reference 9 <b>Reference 9</b>	Sets the frequency reference for the drive. Setting units are determined by parameter o1-03.	Default: 6.09 Hz Range: 0.0 to 400.0 Hz	Yes	All Modes
d1-10 (28Bh)	Frequency Reference 10 <b>Reference 10</b>	Sets the frequency reference for the drive. Setting units are determined by parameter o1-03.	Default: 6.10 Hz Range: 0.0 to 400.0 Hz	Yes	All Modes
d1-11 (28Ch)	Frequency Reference 11 <b>Reference 11</b>	Sets the frequency reference for the drive. Setting units are determined by parameter o1-03.	Default: 6.11 Hz Range: 0.0 to 400.0 Hz	Yes	All Modes
d1-12 (28Dh)	Frequency Reference 12 <b>Reference 12</b>	Sets the frequency reference for the drive. Setting units are determined by parameter o1-03.	Default: 6.12 Hz Range: 0.0 to 400.0 Hz	Yes	All Modes
d1-13 (28Eh)	Frequency Reference 13 <b>Reference 13</b>	Sets the frequency reference for the drive. Setting units are determined by parameter o1-03.	Default: 6.13 Hz Range: 0.0 to 400.0 Hz	Yes	All Modes
d1-14 (28Fh)	Frequency Reference 14 <b>Reference 14</b>	Sets the frequency reference for the drive. Setting units are determined by parameter o1-03.	Default: 6.14 Hz Range: 0.0 to 400.0 Hz	Yes	All Modes
d1-15 (290h)	Frequency Reference 15 <b>Reference 15</b>	Sets the frequency reference for the drive. Setting units are determined by parameter o1-03.	Default: 6.15 Hz Range: 0.0 to 400.0 Hz	Yes	All Modes
d1-16 (291h)	Frequency Reference 16 <b>Reference 16</b>	Sets the frequency reference for the drive. Setting units are determined by parameter o1-03.	Default: 6.16 Hz Range: 0.0 to 400.0 Hz	Yes	All Modes
d2-02 (28Ah)	Frequency Reference Lower Limit <b>Ref Lower Limit</b>	Sets the frequency reference lower limit as a percentage of the maximum output frequency.	Default: 0.0 Range: 0.0 to 0.0 %	No	—
d2-03 (293h)	Master Speed Reference Lower Limit <b>Ref1 Lower Limit</b>	Sets the lower limit for frequency references from analog inputs as a percentage of the maximum output frequency.	Default: 0.0 Range: 0.0 to 0.0 %	No	—
F1-21 (3BCh)	PG1 Signal Selection <b>PG Ch1 Sel</b>	Selects single channel/quadrature detection mode for the PG option card 1. 0: A pulse detection 1: AB pulse detection	Default: 1 Range: 0 to 1	No	OLV/PM CLV
F1-32 (3B1h)	PG2 Rotation Selection <b>PG2 Rotation Sel</b>	Selects the rotation direction of PG option card 2. 0: Pulse A leads 1: Pulse B leads	Default: 0 Range: 0 to 1	No	OLV/PM CLV <>
F1-37 (3BDh)	PG2 Signal Selection <b>PG Ch2 Sel</b>	Selects single channel/quadrature detection mode for the PG option card 2 installed to port CN5-B. 0: A pulse detection 1: AB pulse detection	Default: 1 Range: 0 to 1	No	OLV/PM CLV

## 4 Related Parameters and Functions

No. (Addr. Hex)	Parameter Name Digital Operator Display	Description	Values	Change During Run	Control Mode Access Level
L3-04 (492h)	Stall Prevention Selection <b>StallP Decel Sel</b>	0: Disabled. Deceleration at the active deceleration rate. An ov fault may occur. 1: General purpose. Deceleration is paused when the DC bus voltage exceeds the Stall Prevention level. 2: Intelligent. Decelerate as fast as possible while avoiding ov faults. 3: Stall Prevention with braking resistor. Stall Prevention during deceleration is enabled in coordination with dynamic braking. 4: Overexcitation Deceleration. Decelerates while increasing the motor flux. 5: Overexcitation Deceleration 2. Adjust the deceleration rate according to the DC bus voltage. Note: Setting 3 is not available in models CIMR-A□4A0930 and 4A1200.	Default: 0 Range: 0 to 2	No	<b>All Modes</b>

<1> Setting range value is dependent on parameter C1-10, Accel/Decel Time Setting Units. The settings range becomes 0.00 to 600.00 seconds when C1-10=0 (units of seconds).

<2> Default setting is determined by parameter A1-02, Control Method Selection.

<3> F1-32 is normally only visible when motor 2 is selected. F1-32 is now visible in the correct modes regardless of the motor 2 switch setting.

**Table 4 Additional Group Text**

Function Group	Group Name Digital Operator Display
P	Motion Control Motion Control

**Table 5 Additional Function Text**

Function No.	Group Name Digital Operator Display
P1	Motion Setup Motion Setup
P2	Homing Setup Homing Setup
P3	Advanced Motion Setup Adv Motion Setup
P4	Preset Position Setup Preset Pos Setup

**Table 6 Monitor Function Text**

Monitor No.	Group Name Digital Operator Display
U7	Motion Control Motion Control

**Table 7 Monitors**

No. (Addr. Hex)	Parameter Name Digital Operator Display	Description	Analog Output Scaling	Unit	Control Mode Access Level
U7-02 (0661h)	Distance From Home (Fine) <b>Dist From Home f</b>	Distance from home (+ home offset) for absolute applications, or distance from start of previous move for relative applications. Displayed with fine resolution (0.01 units).	N/A	0.01 Unit </>	<b>All Modes</b>

## 4 Related Parameters and Functions

No. (Addr. Hex)	Parameter Name Digital Operator Display	Description	Analog Output Scaling	Unit	Control Mode Access Level
U7-03 (0662h)	Distance To Go (Fine) <b>Dist To Go f</b>	Distance from the destination. Displayed with fine resolution (0.01 units).	N/A	0.01 Unit <1>	All Modes
U7-04 (0663h)	Commanded Destination (Fine) <b>Commanded Dest f</b>	Commanded destination. Displayed with fine resolution (0.01 units).	N/A	0.01 Unit <1>	All Modes
U7-05 (0664h)	Distance From Home (Coarse) <b>Dist From Home c</b>	Distance from home (+ home offset) for absolute applications, or distance from start of previous move for relative applications. Displayed with coarse resolution (1 unit).	N/A	1 Unit <2>	All Modes
U7-06 (0665h)	Distance To Go (Coarse) <b>Dist To Go c</b>	Distance from the destination. Displayed with coarse resolution (1 unit).	N/A	1 Unit <2>	All Modes
U7-07 (0666h)	Commanded Destination (Coarse) <b>Commanded Dest c</b>	Commanded destination. Displayed with coarse resolution (1 unit).	N/A	1 Unit <2>	All Modes
U7-08 (0667h)	Commanded Speed Reference <b>Cmd Speed Ref</b>	Commanded speed for the selected destination.	N/A	0.01 Hz	All Modes
U7-09 (0668h)	Gray Code Encoder Position <b>Gray Code Pos</b>	Position of the gray code absolute encoder counts in multiples of tens.	N/A	1 dct (deka-count)	All Modes

<1> The actual units text displayed in the digital operator is determined by parameter P1-10. Actual distance in encoder counts is calculated by multiplying the monitor output by P1-09. If the monitor is in excess of 327.67 units, the display will be clamped at 327.67 units. If the monitor is less than -99.99 units, the display will be clamped at -99.99 units.

<2> The actual units text displayed in the digital operator is determined by parameter P1-10. Actual distance in encoder counts is calculated by multiplying the monitor output by P1-09. If the monitor is in excess of 32767 units, the display will be clamped at 32767 units. If the monitor is less than -9999 units, the display will be clamped at -9999 units.

**Table 8 Memobus Registers**

Memobus Address	Description
6D0h	<b>Memobus Communication Speed Reference during a Move</b> Effective only when P1-02 = 1.
6D1h	<b>Memobus Communication Position Reference (Engineering Units)</b> Actual position reference in encoder counts = 6D1h × P1-09. Range is: 0.00 to 655.35 units. Effective only when P1-02 = 1.
6D0h	<b>Memobus 32-bit Communication Position Reference (low word)</b> In quadrature encoder counts. Effective only when P1-02 = 3.
6D1h	<b>Memobus 32-bit Communication Position Reference (high word)</b> In quadrature encoder counts. Effective only when P1-02 = 3.
6E0h	<b>32 Bit Distance From Home (low word) - Read Only</b> Distance from home (+ home offset) for absolute applications, or distance from start of previous move for relative applications. In quadrature encoder counts.
6E1h	<b>32 Bit Distance From Home (high word) - Read Only</b> Distance from home (+ home offset) for absolute applications, or distance from start of previous move for relative applications. In quadrature encoder counts.



Memobus Address	Description
6E2h	<p><b>Motion Control Memobus Status Register - Read Only</b>            Bits 0 to 5 are a copy of the information in monitor U1-11. Bits 8 to E behave the same as the motion control digital outputs (H2-0□ = 40 to 46).            Bit 0: Digital Output Status – M1-M2            Bit 1: Digital Output Status – M3-M4            Bit 2: Digital Output Status – M5-M6            Bit 3: Not Used            Bit 4: Not Used            Bit 5: Not Used            Bit 6: Not Used            Bit 7: Digital Output Status – MA-MB-MC (fault)            Bit 8: Move In Progress            Bit 9: Move Complete            Bit A: Homing Complete            Bit B: Homing Needed            Bit C: At Home            Bit D: Learn Successful            Bit E: Pre-Action Output            Bit F: Not Used</p>

Table 9 Multi-Function Digital Input Settings (H1-□ □)

Setting	Description	Control Mode Access Level
80	<b>MoveClosed:</b> Move to commanded position. (For absolute rotary motion (P1-01 = 2), direction will always be forward.)	CLV
81	<b>Move (Invert)</b> Closed: Move to commanded position × (-1). (For absolute rotary motion (P1-01 = 2), direction will always be reverse.)	CLV
82	<b>Home Command</b> Closed: Starts the homing sequence, must be maintained until Home Complete output is displayed.	CLV
83	<b>Home Switch</b> Closed: Indicates a Home or fixed position of the machine. Also used to indicate Home when using the Manual homing routine (P2-01 = 6).	CLV
84 <I>	<b>Positive Over-travel Limit Switch</b> Closed: If using this feature, it is strongly recommended that a digital input be programmed to Jog Reverse in order to get the machine out of the over-travel condition.	CLV
85 <I>	<b>Negative Over-travel Limit Switch</b> Closed: If using this feature, it is strongly recommended that a digital input be programmed to Jog Forward in order to get the machine out of the over-travel condition.	CLV
86	<b>Learn Position</b> Closed: Allows the storage of the current position. Must be maintained for 1 second.	CLV
87	<b>Distance Select A</b> Closed: Used to select commanded distance/move profile.	CLV
88	<b>Distance Select B</b> Closed: Used to select commanded distance/move profile.	CLV
89	<b>Distance Select C</b> Closed: Used to select commanded distance/move profile.	CLV
8A	<b>Distance Select D</b> Closed: Used to select commanded distance/move profile.	CLV
8B	<b>Disable Motion Control</b> Closed: Motion control is disabled. NOTE: All position information is cleared, requiring another homing routine once re-enabled.	CLV

<I> It is *strongly* recommended that the switch is maintained beyond the trigger point of the switch, all the way to the end of the mechanical limit, when using either of the over-travel switches/inputs. If this cannot be accomplished, an External Fault input would be a better choice. See Chapter 3, Electrical Installation, of the A1000 Technical Manual for a complete description on how to interface with the digital input terminals. Be aware of different types of proximity switches (sinking or sourcing).

## 4 Related Parameters and Functions

**Table 10 Multi-Function Digital Output Settings (H2-□ □)**

Setting	Description	Control Mode Access Level
40	<b>Move In Progress</b> Closed: Drive is completing the specified move profile. Deactivates at the end of a move when machine is within the specified in position window and the motor speed is below the DC Injection at start frequency (B2-01).	CLV
41	<b>Move Complete</b> Closed: Move routine is complete and is within the specified in position window and motor speed is below the DC Injection start frequency. Deactivates when the move command is removed. If a momentary move command is utilized (P1-03 = 1 or 2), this output deactivates when another move command is given.	CLV
42	<b>Homing Complete</b> Closed: A homing routine has been completed. The drive knows its position relative to the home switch, and has moved to the home + home offset position (P2-06).	CLV
43	<b>Homing Needed</b> Closed: A successful homing routine has not been completed.	CLV
44	<b>At Home</b> Closed: The drive is within +/- the in position of home (home + home offset).	CLV
45	<b>Learn Successful</b> Closes when the drive has successfully learned the present position. Opens when the learn command is removed.	CLV
46	<b>Pre-Action</b> Closes when distance from commanded destination is less than parameter P2-08. Opens when distance from commanded destination is less than parameter P1-08. Deactivates when the move command is removed.	CLV

**Table 11 Multi-Function Analog Input Settings (H3-□ □)**

Setting	Description	Control Mode Access Level
20	<b>Ser Enc Drv Dis</b> (Absolute Incremental Encoder Drive Disable) Used by the absolute incremental encoder to disable the drive when transferring position information.	All Modes

**Table 12 Multi-Function Analog Output Settings (H4-□ □)**

Setting	Description	Control Mode Access Level
710	<b>Ser Enc Pos Req</b> (Absolute Incremental Encoder Position Request) The drive outputs a 10V signal to the absolute encoder to begin the position request routine.	All Modes



## ◆ Faults and Alarms

Table 13 Faults

Fault Indication LCD <Memobus>	Description	Cause	Countermeasures
Multi-Function Input Selection Error <b>OPE03</b> <b>Terminal</b>	Multi-function Input Selection Error. <1>	<ul style="list-style-type: none"> <li>• Motion control is enabled (P1-01&gt;0) and 3-wire control is enabled (One of the H1 parameters is set to 0-3-Wire Control)</li> <li>• Motion control is enabled (P1-01 &gt; 0) and Motor 2 Select is programmed into an H1 parameter</li> </ul>	<ul style="list-style-type: none"> <li>• Disable the motion control by setting P1-01 = 0, or reprogram the H1 parameter that is set to 0</li> <li>• Disable the motion control by setting P1-01 = 0, or reprogram the H1 parameter that is set to 16</li> </ul>
Option Card Selection Error <b>OPE05</b> <b>Sequence Select</b>	Option Card Selection Error	Distance Select is programmed for Option PCB Fref (P1-02 = 2) and no communications option is installed at connector CN5-A	Re-program parameter P1-02, or install communications option board
Motion Control Setup Error <b>OPE12</b> <b>Motion Ctrl Stup</b>	Motion Control Setup Error	<ul style="list-style-type: none"> <li>• Absolute Encoder is selected (P3-01 = 2) AND motion type is not Linear Absolute (P1-01 &gt;=2)</li> <li>• Absolute Encoder is selected (P3-01 = 2) AND a DI-A3 option board is not installed</li> <li>• The numerator (P3-03) is set more than 100 times greater than the denominator (P3-04)</li> <li>• Encoder type is set to Serial Abs Ch1 and encoder rotation is set to CW. (P3-01 = 3 and F1-05 = 1)</li> <li>• Motion Control is enabled (P1-01&gt;0) and either PG1 Signal Select (F1-21) or PG2 Signal Select (F1-37) is set to only A Phase Detection (0)</li> </ul>	<ul style="list-style-type: none"> <li>• Adjust motion type or encoder type</li> <li>• Adjust motion type or encoder type or install a DI-A3 option board.</li> <li>• Adjust the numerator and the denominator</li> <li>• Adjust parameter F1-05 back to zero and change PG Ch. 1 feedback wiring</li> <li>• Disable Motion Control or set PG1 and PG2 to A and B Phase Detection</li> </ul>
Second Encoder Fault <b>2ENFL</b> <b>2nd Enc. Fault</b>	There is a problem with the encoder connected to the PG-X3 card in slot CN5-B or with the absolute encoder connected to the DI-A3.	<ul style="list-style-type: none"> <li>• Incremental encoder connected to PG-X3 card in slot CN5-B has opposite rotation from the motor encoder</li> <li>• Absolute encoder has either rolled over and no longer contains valid position data, or has opposite rotation from the motor encoder</li> </ul>	<ul style="list-style-type: none"> <li>• Switch the polarity of the incremental encoder connected to the 2<sup>nd</sup> channel, by swapping terminals A+ and A- on the PG-X3 card in slot CN5-B</li> <li>• Mechanically reset the absolute encoder, or force the encoder to count in the opposite direction</li> </ul>
Position Overflow Fault <b>POSOF</b> <b>Position Ovrflow</b>	The internal register that tracks position has exceeded its limits, DURING a motion-control move.	The distance from home (or home + home offset) has exceeded 10 <sup>9</sup> encoder counts.	Re-home and verify position of moving equipment.
Serial Encoder Fault <b>SENCF</b> <b>Ser Enc Fault</b>	Absolute Incremental Encoder fault.	The drive did NOT receive valid data/control signals from the absolute incremental encoder within 35 seconds after power up or home command.	Check encoder and wiring, Check that an analog input and output are programmed and wired properly for a absolute incremental encoder.

<1> An OPE03 error can be caused by many other conditions as well. These conditions are listed in Section 6 of the A1000 Technical Manual (SIEPC71061641).

## 4 Related Parameters and Functions

**Table 14 Alarms**

Alarm Indication LCD <Memobus>	Description	Cause	Countermeasures
Run Homing Sequence RHS Run Homing Seq	Run Homing Sequence	A move or learn command was given before the drive has been homed. This will only occur when P1-01 = 1 or 2.	Perform a homing routine.
Positive Over Travel POSOT Pos Ovr Travel	Positive Over Travel	The machine has moved past the positive over-travel switch.	Drive can be moved out of positive over-travel using the Jog Reverse input.
Negative Over Travel NEGOT Neg Ovr Travel	Negative Over Travel	The machine has moved past the negative over-travel switch.	Drive can be moved out of negative over-travel using the Jog Forward input.
Position Out of Range POSOR Out of Range	Position Out of Range	The drive has been commanded to learn a position that is out of range of learning.	Open the learn position digital input to stop trying to learn the position.
Serial Encoder Reading SENCR Ser Enc Reading	The drive is receiving position information from the absolute incremental encoder. All run commands are ignored during this time.	Absolute incremental encoder is reporting its position by bringing a multi-function input (A2 or A3) above 9 V.	Wait for absolute incremental encoder to finish (35 sec. Max), or troubleshoot analog input wiring.
Serial Encoder Fault SENCF Ser Enc Fault	Absolute Incremental Encoder fault.	The drive did NOT receive valid data/control signals from the absolute incremental encoder within 35 seconds after power up or home command.	Check encoder and wiring, Check that an analog input and output are programmed and wired properly for a absolute incremental encoder
Learning Position LEARN Learning Pos	The Learn Position digital input is closed and the drive is learning the current position. This takes 1 second to complete.	The drive is Learning the current position.	Open the Learn Position digital input before the position is learned. Or, once the position is learned, the display will clear and the Learn Complete digital output and message will appear.
Learning Complete LEARN Learn Complete	The Learn Position digital input has been closed for at least 1 second and the current position has been stored in the P4 parameter specified by the user. The Learn Complete digital output is also closed.	The current position has been stored in the P4 parameter specified by the user and the Learn Complete digital output is also closed.	Open the Learn Position digital input.

## 5 Function Description

### ◆ Types of Motion

#### ■ Linear Absolute Motion

Linear absolute motion would be used in applications such as: ball screws, linear slides, and transfer stations. With this type of motion, a home switch and a homing sequence or an absolute encoder are required. All position references are with relation to the actual home position + home offset.

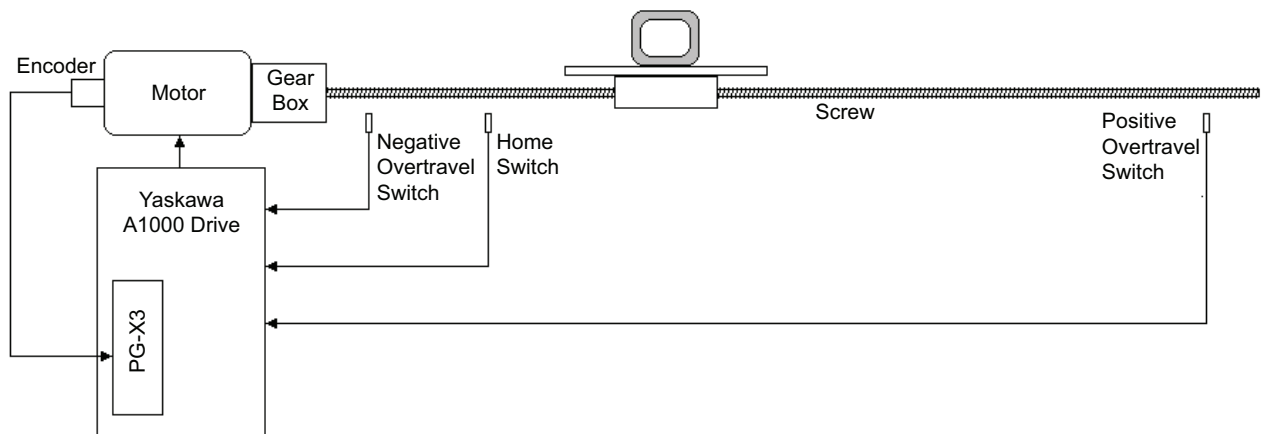

Figure 1 Linear Absolute Motion Example - Ball Screw

#### ■ Rotary Absolute Motion

Rotary absolute motion would be used in application such as: index turntables, turret winders and dial tables. With this type of motion, a home switch and a homing sequence is required. All position references are with relation to the actual home position + home offset.

In any Homing routine, the final move to home will only be in the positive direction. If the Homing routine is Positive (P2-01 = 2, 3, or 5) when the rising edge of the home switch is encountered, the drive will then perform a move to home. This will cause more forward motion beyond the home switch. If the home offset (P2-06), is set to 0, the machine will move one complete revolution at the end of the homing routine.

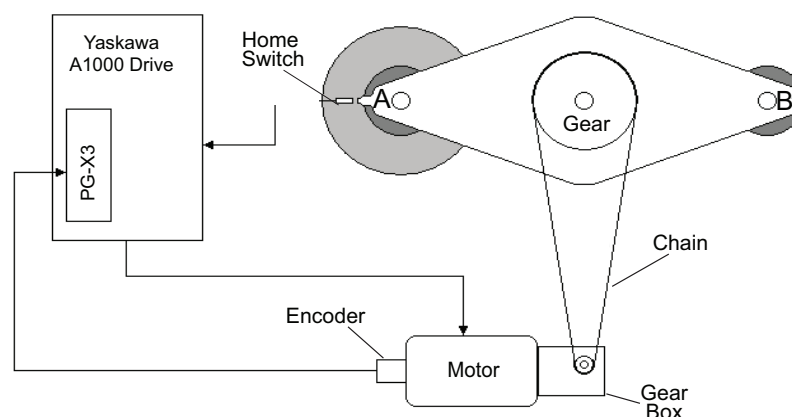

Figure 2 Rotary Absolute Motion Example - Turret Winder

## 5 Function Description

### ■ Relative Motion

Relative motion would be used in applications such as cut-to-length and metering pumps. Can be used with or without a homing sequence. When the motion type is *Relative Mem Off* (P1-01 = 3) the move distance is measured from the position at the time of the move command. When the motion type is *Relative Mem On* (P1-01 = 4), the distance is measured from the destination of the previous move. If a conveyor with pockets or flights is being indexed, *Relative Mem On* would be the appropriate motion type.

When the motion type is *Relative Mem On* and a move is interrupted before completing, the drive checks to see if it is within the *In Position Window* of its previously commanded destination when a new move is commanded. As an example, consider a commanded move distance of 5.00 units. If the drive moves 2.00 units before the move is interrupted, it then checks to see if it's within the in position window of its destination of 5.00 units. If it has not yet reached the in position window and another move command is given, the drive will move 3.00 units from its current position to complete its original move of 5.00 units. If the in position window is set large enough that the drive was within this window when it stopped at 2.00 units, the next time a move command is given, the drive will move a total of 8.00 units – 3.00 units to complete its original move plus 5.00 units for the newly commanded move.

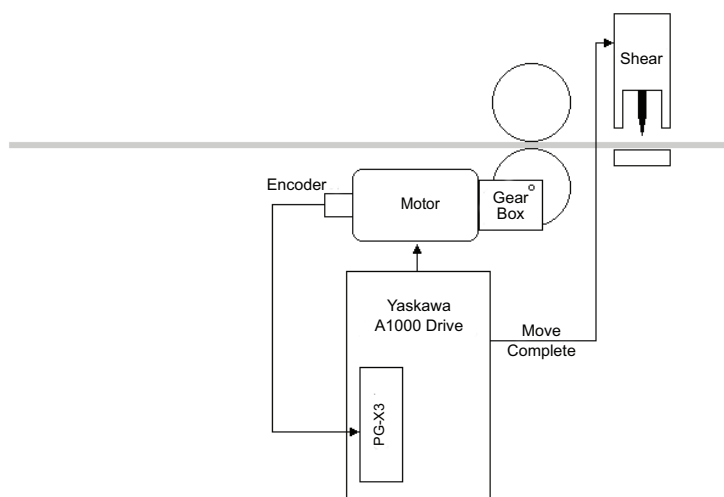

Figure 3 Relative Motion Example - Cut to Length

### ◆ Command Position

#### ■ Digital Preset

Up to 16 different digital preset positions can be programmed. Each position is set in user selectable units, set up by parameters P1-09 and P1-10. Distance in encoder counts can be calculated by multiplying the digital preset value by parameter P1-09 (counts per rev). Encoder counts refers to the counts after quadrature. The counts after quadrature is typically four times that of the Pulses Per Revolution rating of all compatible encoders except the absolute gray code type. Encoder counts are not multiplied by 4 for the gray code type of encoder. Move velocity is determined by a different parameter for each digital preset position. Accel and decel rates will be one of four different sets as shown in [Table 15](#).

#### ■ Memobus Distance

One 16 bit Memobus register is used to command a speed during a move, and one 16 bit Memobus register is used to command a position. Memobus register 06D0h holds the speed reference (in 0.01 Hz), and register 06D1h holds the position reference in engineering units. These registers can be written to using the drive's built-in Memobus communications, or by other optional protocols such as DeviceNet, Ethernet or Profibus. Accel and decel rates are determined by parameters C1-01 and C1-02.

#### ■ Option PCB (Frequency Reference) Register

In this mode, the drive's option PCB frequency reference is redefined and used as the commanded distance. The commanded position originates from the *Frequency Reference* channel of the option board.

The position reference is scaled as follows: Commanded Position (in encoder counts) = Frequency Reference × P1-09. Move velocity is determined by parameter d1-09, and accel and decel rates are determined by parameters C1-01 and C1-02. For example:

If P1-09 = 4096 counts/unit, and the frequency reference over the option PCB is 15.00 Hz, this would result in a move that is exactly 61440 encoder counts (4096 × 15.00 = 61440). The option frequency reference channel returns to normal operation as an actual frequency reference when motion control is disabled.

1. The position reference is scaled as follows:

$$\text{Commanded Position (in encoder counts)} = \text{Frequency Reference} \times \text{P1-09}$$

2. Move velocity is determined by parameter d1-09, and accel and decel rates are determined by parameters C1-01 and C1-02.

For example: If P1-09 = 4096 counts/unit, and the frequency reference over the option PCB is 15.00 Hz, this would result in a move that is exactly 61440 encoder counts (4096 × 15.00 = 61440).

When motion control is disabled, the option frequency reference channel returns to normal operation as an actual frequency reference.

**Table 15 Profile Selection Information**

Distance Select D <1>	Distance Select C <1>	Distance Select B <1>	Distance Select A <1>	Parameter P1-02 Setting	Position Reference Source	Accel/Decel Parameters	Max Speed Used
Open	Open	Open	Open	0	Parameter P4-01	C1-01 and C1-02	d1-09
				1	Memobus Address 06D1h 100=1.00 Units <2>		Memobus Address 06D0h
				2	Option PCB Frequency Reference Register <3> <4> (in XXX.XX Units)		d1-09
				3	Memobus Address 06D0h (low word) and 06D1h (high word) In quadrature encoder counts.		
Open	Open	Open	Closed	N/A	P4-02	C1-03 & C1-04	d1-10
Open	Open	Closed	Open	N/A	P4-03	C1-05 & C1-06	d1-11
Open	Open	Closed	Closed	N/A	P4-04	C1-07 & C1-08	d1-12
Open	Closed	Open	Open	N/A	P4-05	C1-01 & C1-02	d1-13
Open	Closed	Open	Closed	N/A	P4-06	C1-03 & C1-04	d1-14
Open	Closed	Closed	Open	N/A	P4-07	C1-05 & C1-06	d1-15
Open	Closed	Closed	Closed	N/A	P4-08	C1-07 & C1-08	d1-16
Closed	Open	Open	Open	N/A	P4-09	C1-01 & C1-02	d1-09
Closed	Open	Open	Closed	N/A	P4-10	C1-03 & C1-04	d1-10
Closed	Open	Closed	Open	N/A	P4-11	C1-05 & C1-06	d1-11
Closed	Open	Closed	Closed	N/A	P4-12	C1-07 & C1-08	d1-12
Closed	Closed	Open	Open	N/A	P4-13	C1-01 & C1-02	d1-13
Closed	Closed	Open	Closed	N/A	P4-14	C1-03 & C1-04	d1-14
Closed	Closed	Closed	Open	N/A	P4-15	C1-05 & C1-06	d1-15
Closed	Closed	Closed	Closed	N/A	P4-16	C1-07 & C1-08	d1-16

<1> Programmable using the digital input parameters H1-01 to H1-10.

<2> When P1-02=1, the actual commanded destination is calculated as follows:

$$\text{Destination} = \text{Memobus register 6D0H} \times \text{P1-09}/100$$

<3> Actual destination (in encoder quadrature counts) is calculated as follows when b1-01= 3:

$$\text{Destination} = \frac{\text{Frequency Reference (hi-speed rgister)}}{100} \times \text{P1-10}$$

<4> When motion control is disabled, the Option PCB frequency reference register returns to its normal function.

## 5 Function Description

### ■ Encoders

#### Single Incremental Encoder

The encoder used for positioning is mounted to the motor, and serves two purposes. One is to provide velocity feedback for the Flux Vector control method, and the other is to provide position information to the motion control software. In order for this to work, there needs to be a positive drive setup, such as a direct-coupled gear box or a cogged timing belt between the motor and the load. When this scheme is employed, there is no compensation for backlash or slack in the mechanical system. A PG-X3 or a PG-B3 encoder feedback card is required to be installed in the CN5-C option card slot.

**Note:** Wiring between for the encoder marker pulse (Z+ and Z-) is only required if using a *Homing w/marker* homing routine (P2-01=4 or 5).

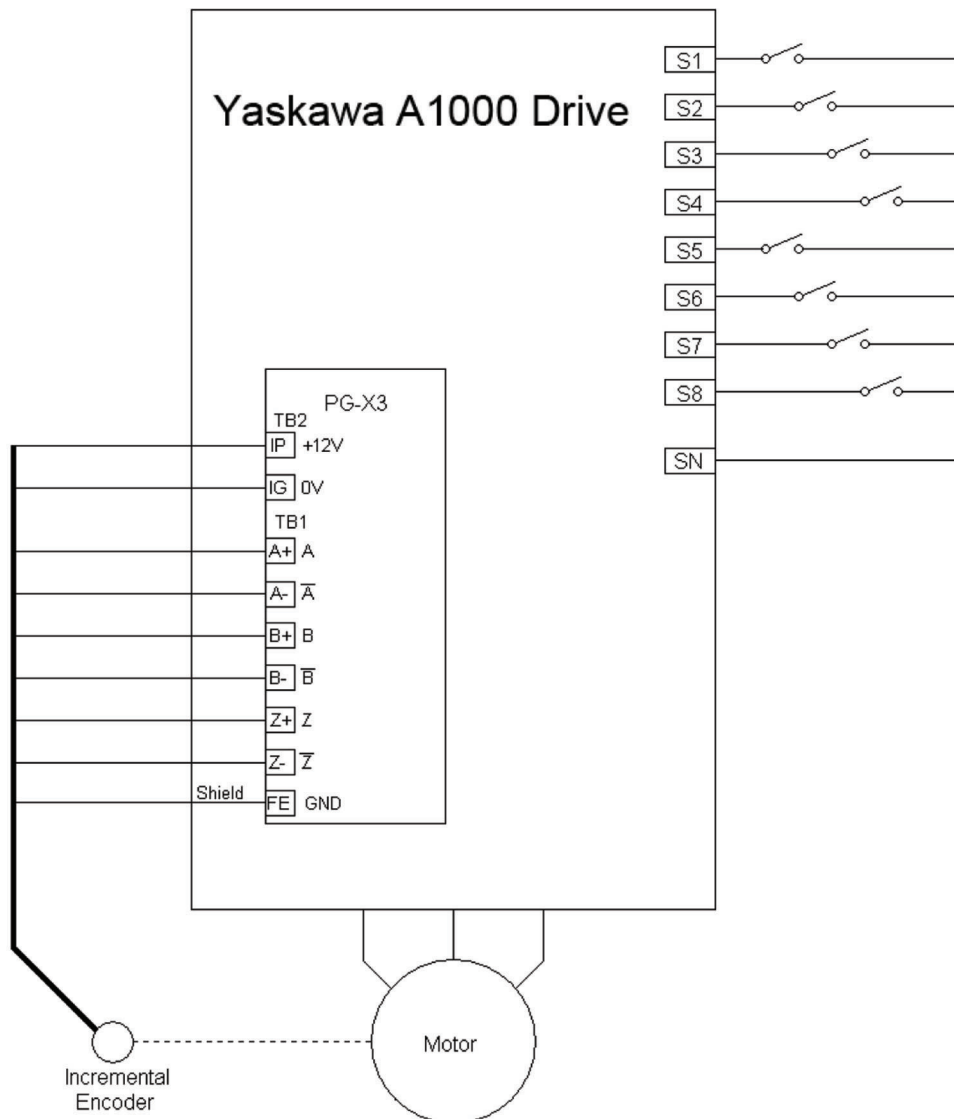

Figure 4 Single Incremental Encoder Wiring (P3-01=0)

**Dual Incremental Encoders**

The encoder used for position is mounted elsewhere on the machine. The need for a positive drive setup is somewhat reduced using this scheme. A second motor-mounted encoder is required for optimum performance. The ratio between the motor and the machine-mounted encoder needs to be entered into parameters P3-03 and P3-04, and the PPR of the encoder needs to be entered into P3-02. Note that parameter F1-31 is ignored in the Motion Control software. The gear ratio numerator (P3-03) and denominator

Parameter P3-04 is relative to the positioning axis (machine mounted encoder), not the motor. For example, if the motor is connected to the axis where the positioning encoder is mounted via a 2:1 gearbox (meaning, for every 2 rotations of the motor shaft, the secondary positioning encoder turns 1 rotation), P3-03 should be set to 1 and P3-04 should be set to 2.

This configuration requires a second PG-X3 or PG-B3 card installed in the CN5-B option card slot.

**Note:** Wiring between for the encoder marker pulse (Z+ and Z-) is only required if using a *Homing w/marker* homing routine (P2-01 = 4 or 5).

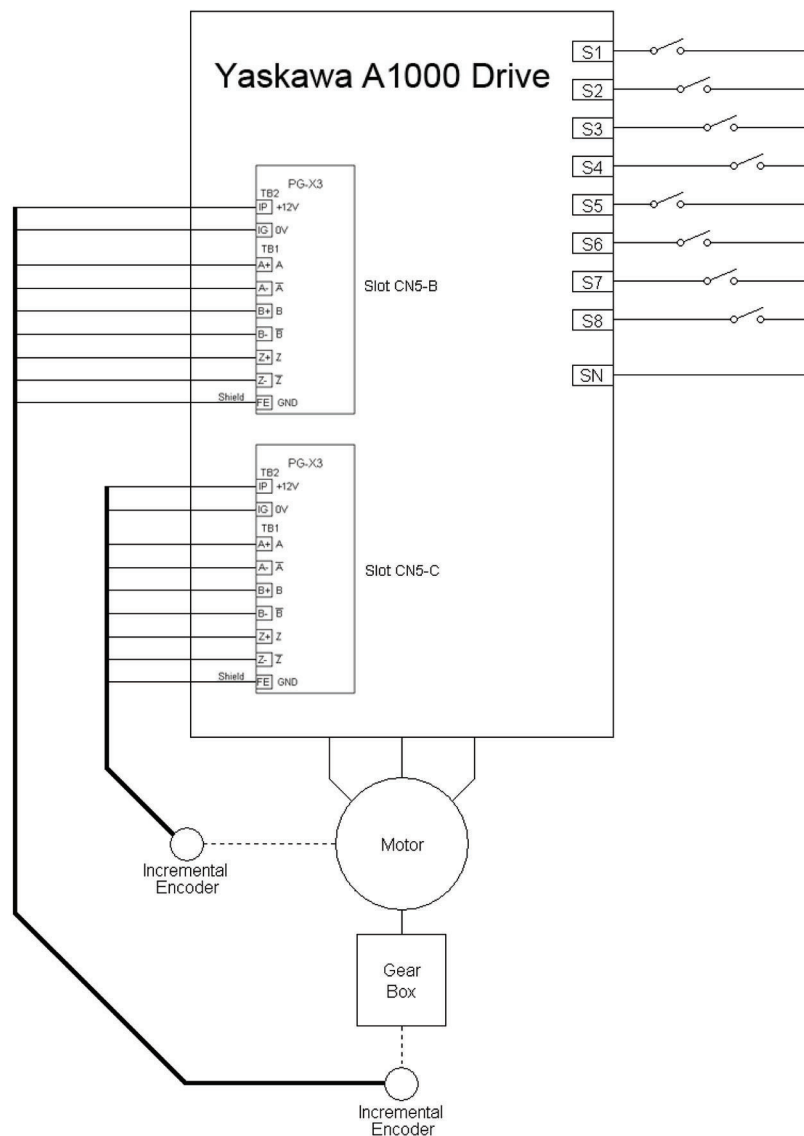

**Figure 5 Dual Incremental Encoder Wiring (P3-01=1)**

## 5 Function Description

### Absolute (Gray Code) Encoder

An absolute (gray code) encoder can be machine-mounted or motor-mounted. This style of encoder can be used only if the motion type is Linear Absolute. If the absolute encoder is machine mounted, the ratio between the motor and the encoder must be entered into parameters P3-03 and P3-04, and the encoder COUNTS per revolution must be entered into P3-02. Note that parameter F1-31 is ignored in the Motion Control software. A DI-A3 digital input option card is required and an external power supply for the encoder. Encoder outputs must be 24 Vdc and be capable of sinking current when a logic low is present on the output.

This software was tested with a Danaher/Dynapar brand 12 bit by 12 bit gray code encoder, part number: ai2512122b121.

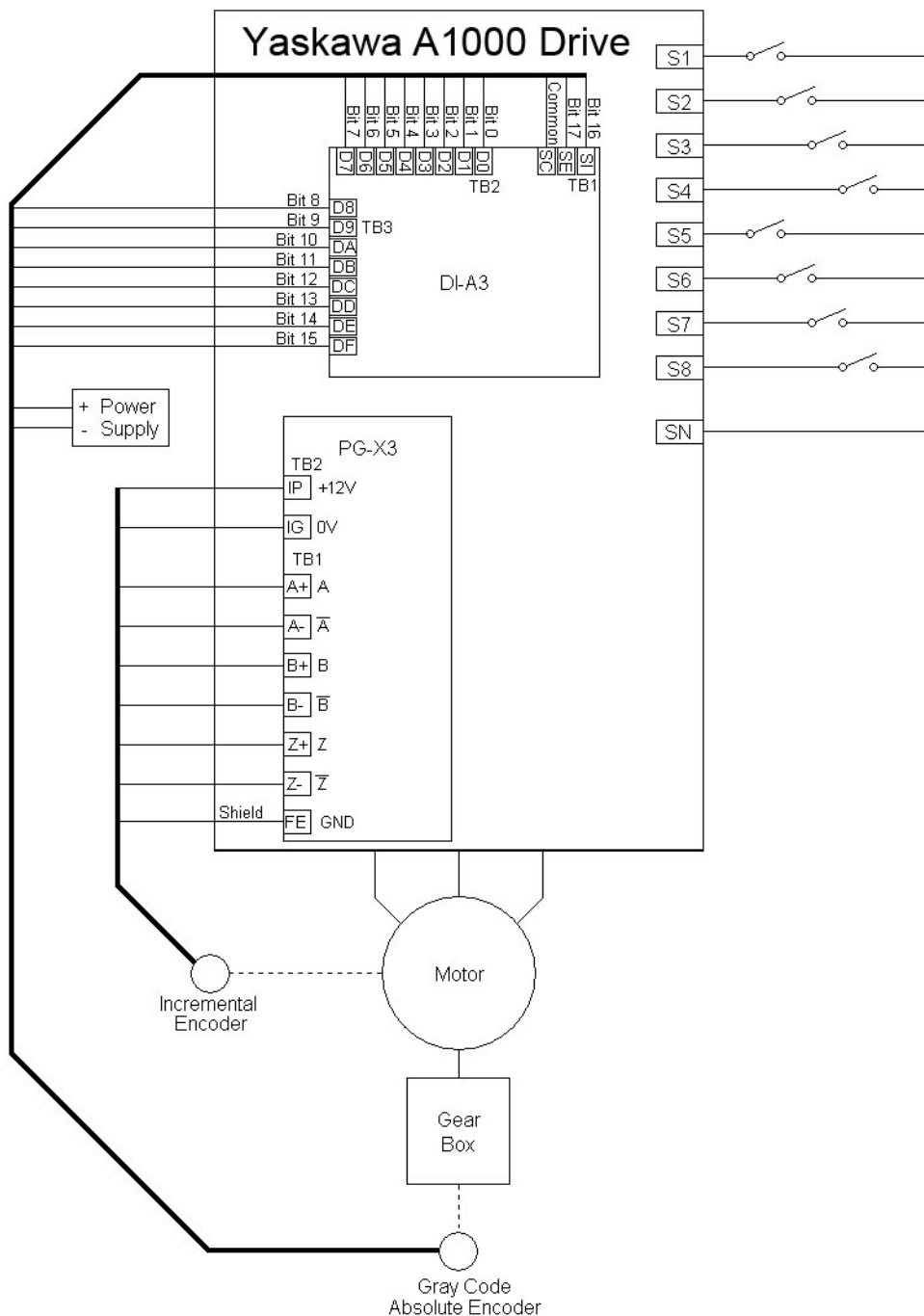
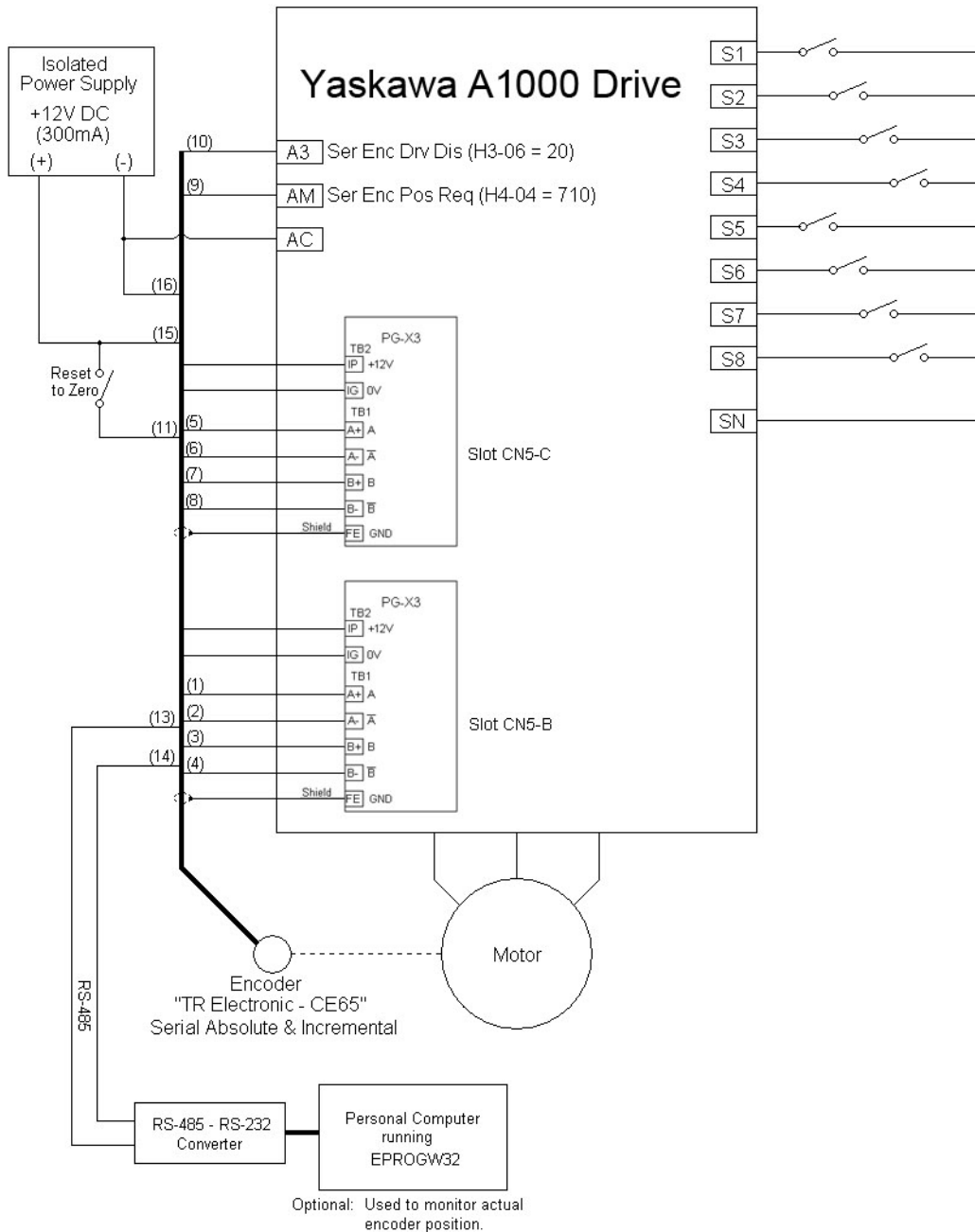

Figure 6 Gray Code Absolute Encoder Wiring (P3-01=2)



**Absolute Incremental Encoder**

For use with a TR-electronic, series CE-65 serial (ISI) encoder. The drive must read the actual position of the absolute incremental encoder upon power up. This process usually is completed within a few seconds. As an option, the encoder can be monitored and configured directly using a PC, an RS-232 to RS-485 converter, and the TR Electronic EPROGW32 program.



**Figure 7 Absolute Incremental Encoder Wiring (P3-01=3)**

**Note:** Change the terminal AM gain (H4-05) from the default setting of 50.0% to 200.0% when using terminal AM for the Serial Encoder Position Request (H4-04 = 710). Otherwise, the serial encoder read request will fail and a SENC F (Serial Encoder Fault) will occur.

## 5 Function Description

### Absolute Incremental Encoder w/Separate Incremental Encoder

For use with a TR-electronic, series CE-65 serial (ISI) encoder. The drive must read the actual position of the serial encoder upon power up,. This process usually is completed within a few seconds. As an option, the encoder can be monitored and configured directly using a PC, an RS-232 to RS-485 converter, and the TR Electronic EPROGW32 program.

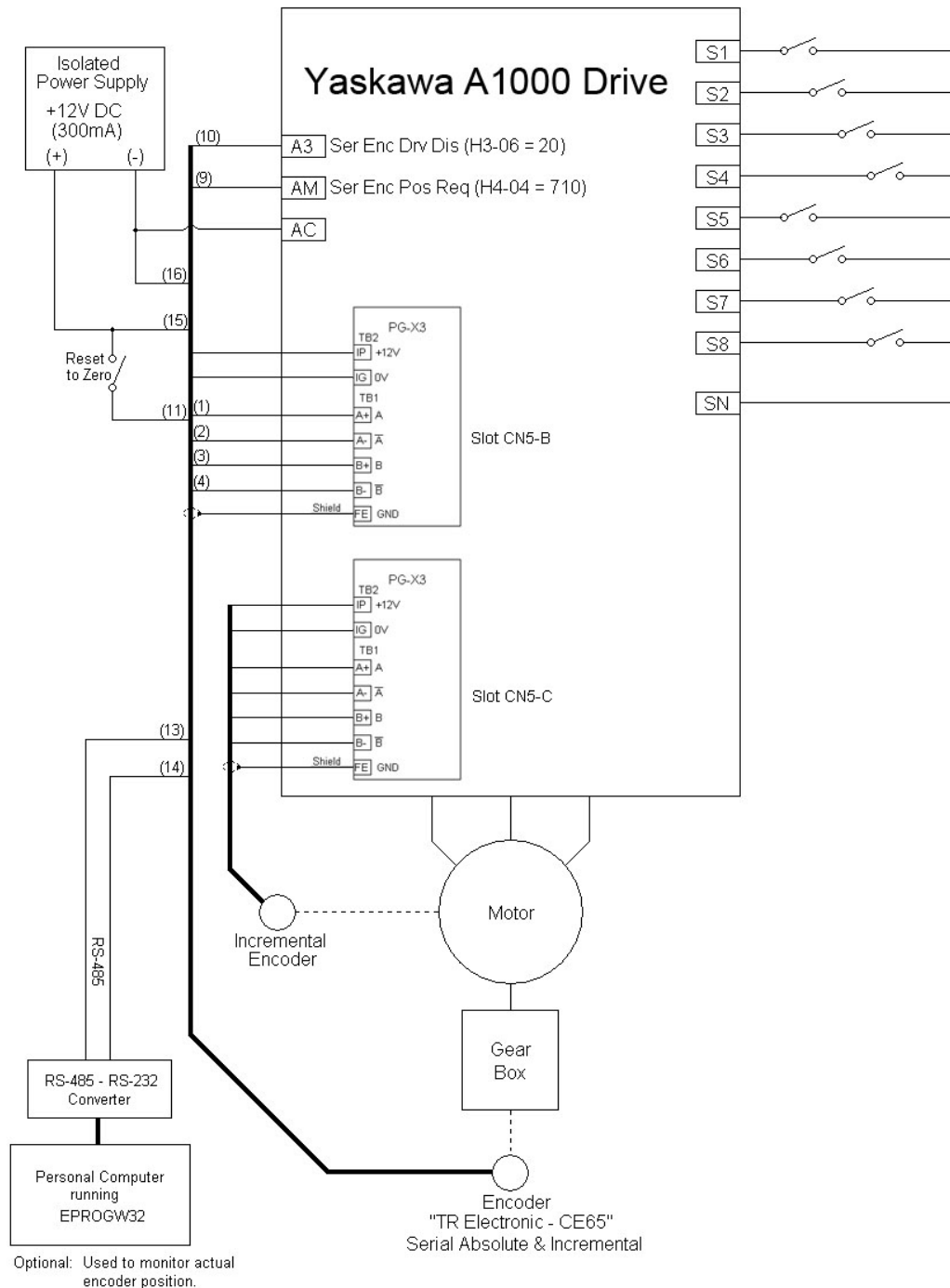

**Figure 8 Absolute Incremental Encoder Wiring - Dual Encoders (P3-01=4)**

- Note:**
1. The wiring above is for a TR Electronic brand encoder model #: CE65M-G-4096/4096-D23BB-R10HR/HX. 4096 counts/rev, +/-2048 revolutions (multi-turn)
  2. Change the terminal AM gain (H4-05) from the default setting of 50.0% to 200.0% when using terminal AM for the Serial Encoder Position Request (H4-04 = 710). Otherwise, the serial encoder read request will fail and a SENCN (Serial Encoder Fault) will occur.

## ■ Motion and Velocity Profile

### Command Position

The commanded position is determined by the multi-function inputs and by the setting of parameter P1-02.

### Move Velocity

The speed of the move is determined by one of the d1 parameters, as shown in [Table 3](#) on page [11](#). The drive will attempt to perform a trapezoidal move. If, due to the accel and decel rates, move velocity and commanded position, the drive cannot reach the full move velocity, the move will be triangular. If an alternate frequency reference or jog is commanded via multi-function inputs during a move, the drive will run at the new commanded or jog speed until it is no longer activated, at which time the move will be canceled, and the drive will ramp to zero speed. The position is tracked when operating at an alternate commanded frequency reference or in local mode. If the internal register that tracks position (or position + home offset) exceeds  $10^9$  encoder counts, the drive/machine will need to be re-homed. If motion control is disabled (either via parameter P1-01 or the *Motion Disable* multi-function input), the drive no longer tracks position, and may need to be re-homed depending on encoder type and move type.

### Positioning Routine

When a move is commanded, the drive will accelerate on the selected acceleration ramp up to the commanded move velocity. During this time the drive is calculating both when to start the deceleration ramp and the optimum positioning speed, based on the current position, current velocity, selected decel rate, and position regulator gain. When the *begin decel* point is reached, the drive's speed reference will be clamped at the calculated positioning speed and the drive will decelerate on the selected deceleration ramp. Once the machine speed is at or below the positioning speed the speed will be completely controlled by the position regulator, with a speed limit of positioning speed. When the machine then enters the *in position* window, and the motor speed is below the DC injection start frequency (b2-01) the *in position* digital output is activated and the drive seeks to resolve all position error.

A RUN command must be present prior to commanding a move. If the move is commanded before the run command, the move command is ignored and the drive remains at zero speed. If the RUN command is removed during a move, parameter b1-03 determines the stopping method. If the stopping method is *Ramp To Stop*, the decel rate used is the one selected at the beginning of the move.

The motion and velocity profile is latched in at the beginning of the move. If the position, velocity or accel/decel is changed during the move, it will be ignored until the next move command is given.

If an absolute move is commanded before the drive has been homed, a warning is displayed: RHS Run Homing Sequence and the drive remains at zero speed.

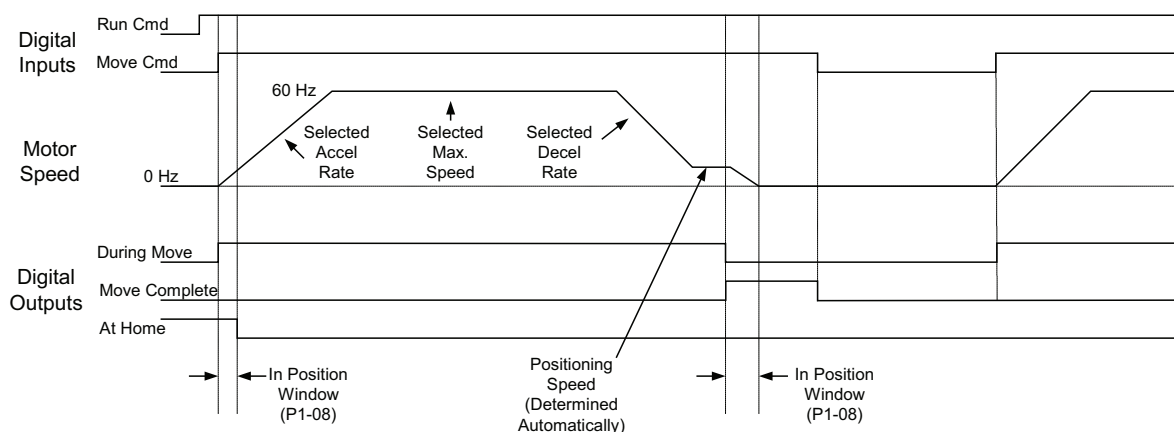
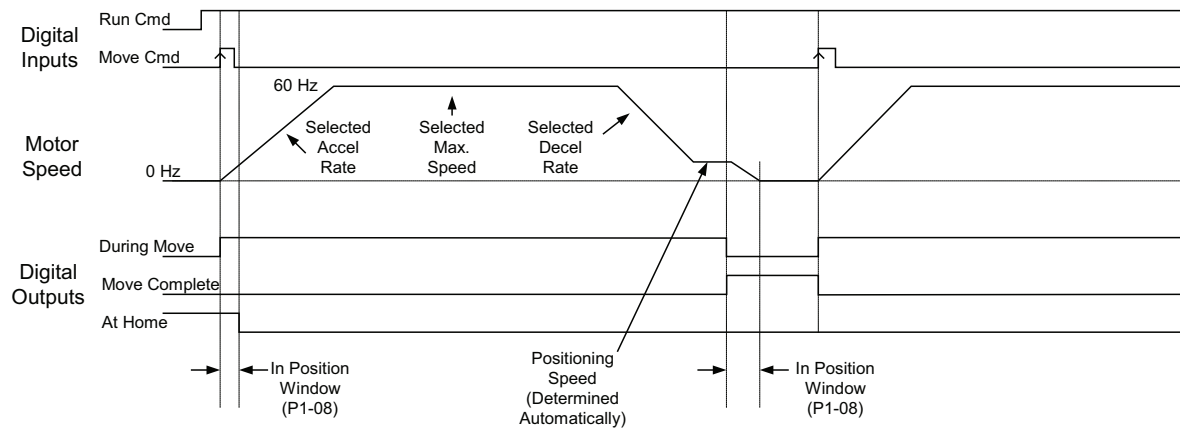
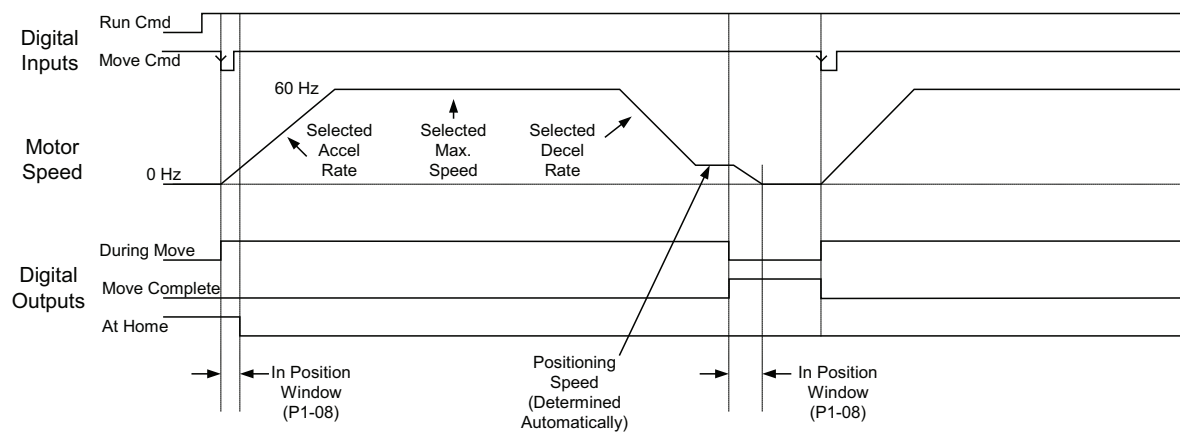

Figure 9 Typical Move Profile From Home to a Positive Position-Maintained Move Command (P3-01=0)

## 5 Function Description



**Figure 10 Typical Move Profile From Home to a Positive Position-Rising Edge Type Move Command (P3-01=1)**



**Figure 11 Typical Move Profile From Home to a Positive Position-Falling Edge Type Move Command (P3-01=2)**

## ■ Homing

Homing is required in order to orient the drive to the mechanical system. A homing routine may or may not be required depending on the motion type and encoder type. If the selected motion type is absolute linear or absolute rotary (P1-01 = 1 or 2), and an absolute encoder is not present, homing will be required at power-up, when motion control is re-enabled after being disabled, when motion type is changed (P1-01) or when encoder type is changed (P3-01). Switching the drive into *Local* mode will NOT require the drive to be re-homed.

### Home Negative

When the *home command* input is closed, the drive will accelerate using the C1-07 ramp in the negative (reverse) direction at the homing speed. As soon as the home switch is activated, the drive records the position as home then decelerates using the decel rate specified in parameter C1-08. The drive then performs a move to *home + home offset* using d1-16 as the speed, and C1-01 and C1-02 as the accel and decel ramps.

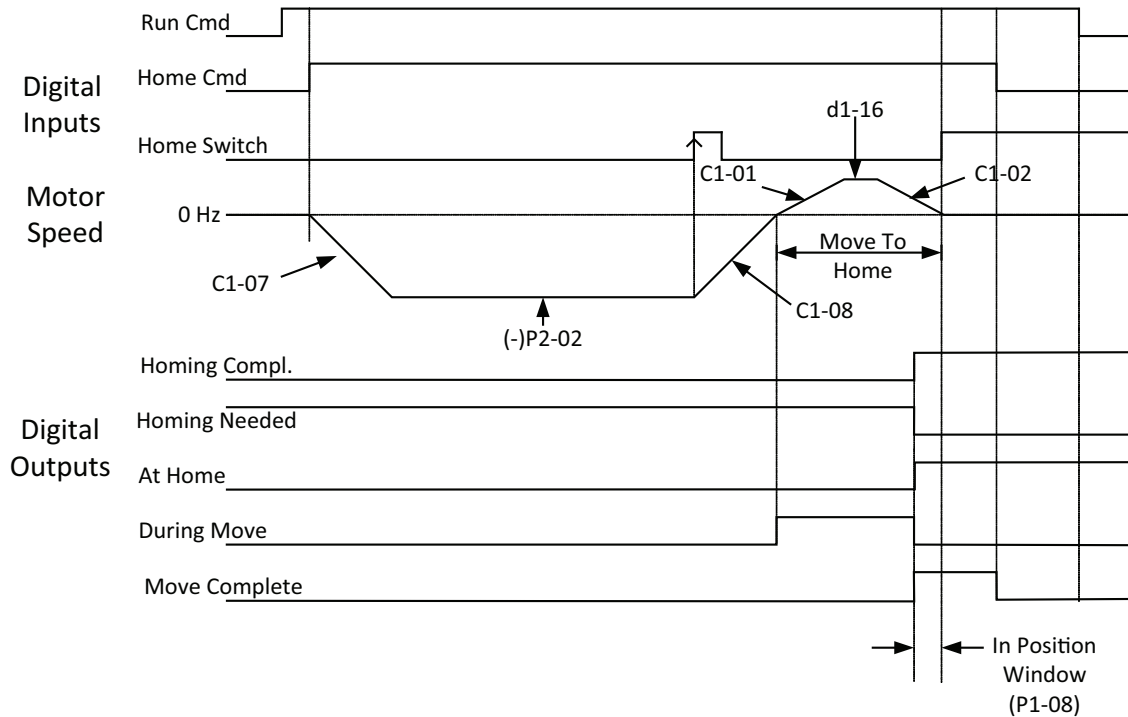

Figure 12 Home Negative Timing Chart (P2-01=0)

## 5 Function Description

### Home Negative with Backup

The drive will accelerate using the C1-07 ramp in the negative (reverse) at the homing speed when the *home command* input is closed. When the home switch is activated, the drive will then proceed positive (forward) at the homing backup speed until the home switch is de-activated. The drive will then switch back into reverse and proceed at the homing final speed. The drive records the position as home and decelerates to zero speed as soon as the home switch is re-activated. The drive then performs a move to *home + home offset* using d1-16 as the speed, and C1-01 and C1-02 as the accel and decel ramps. The homing needed output is deactivated and the homing complete output is activated when complete.

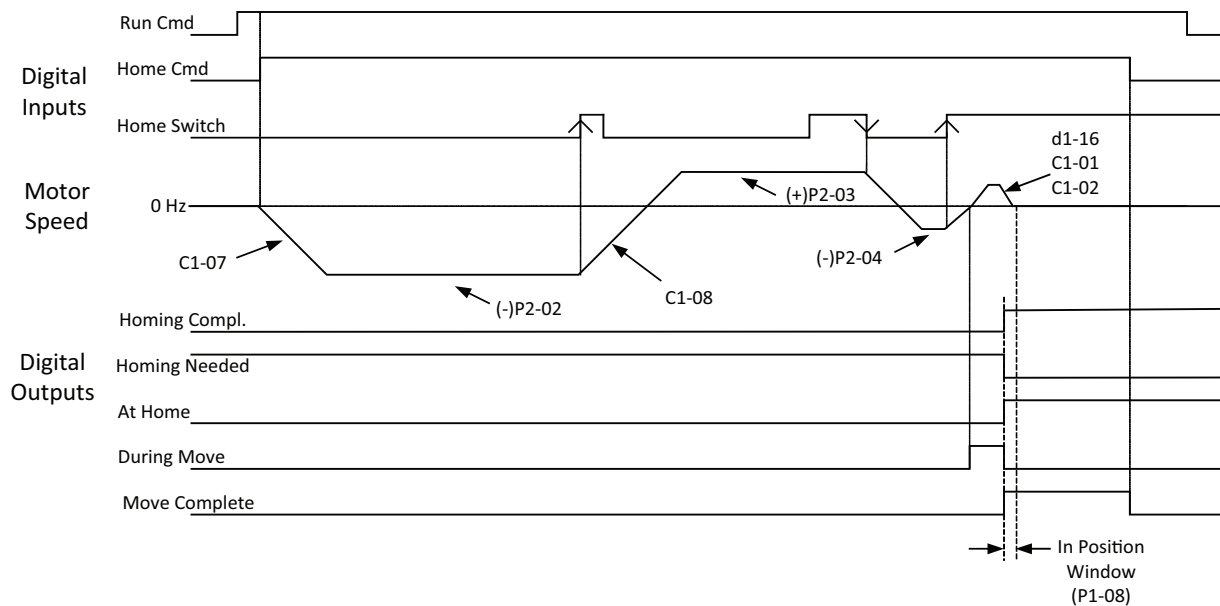

Figure 13 Home Negative with Backup Timing Chart (P2-01=1)

### Home Positive

Home positive uses the same sequence as home negative, but the drive proceeds in the positive (forward) direction at the homing speed.

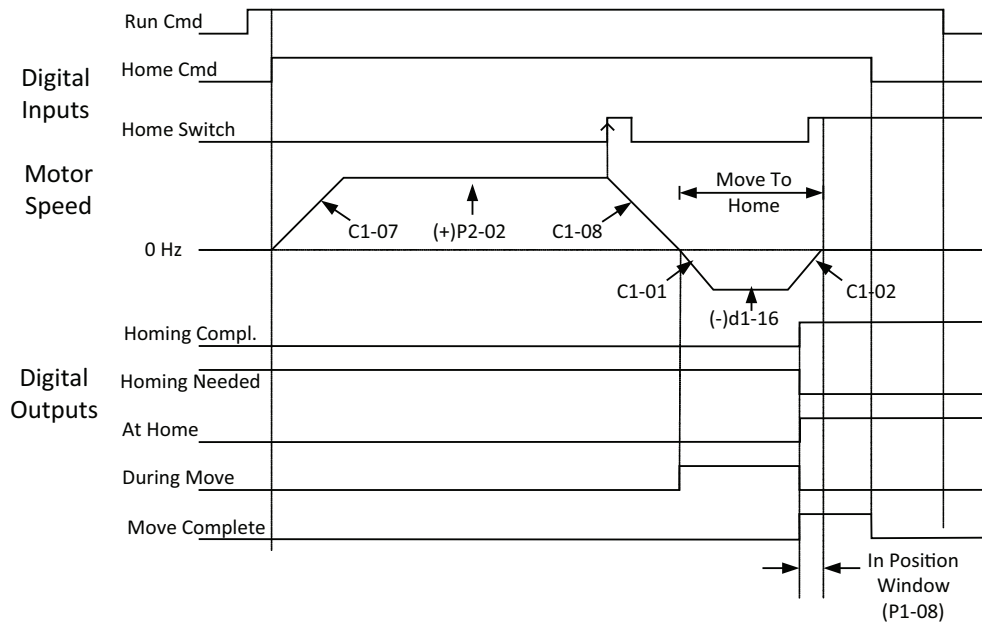

Figure 14 Home Positive Timing Chart (P2-01=2)

### Home Positive with Backup

Home positive with backup uses the same sequence as home negative with backup, but directions are opposite.

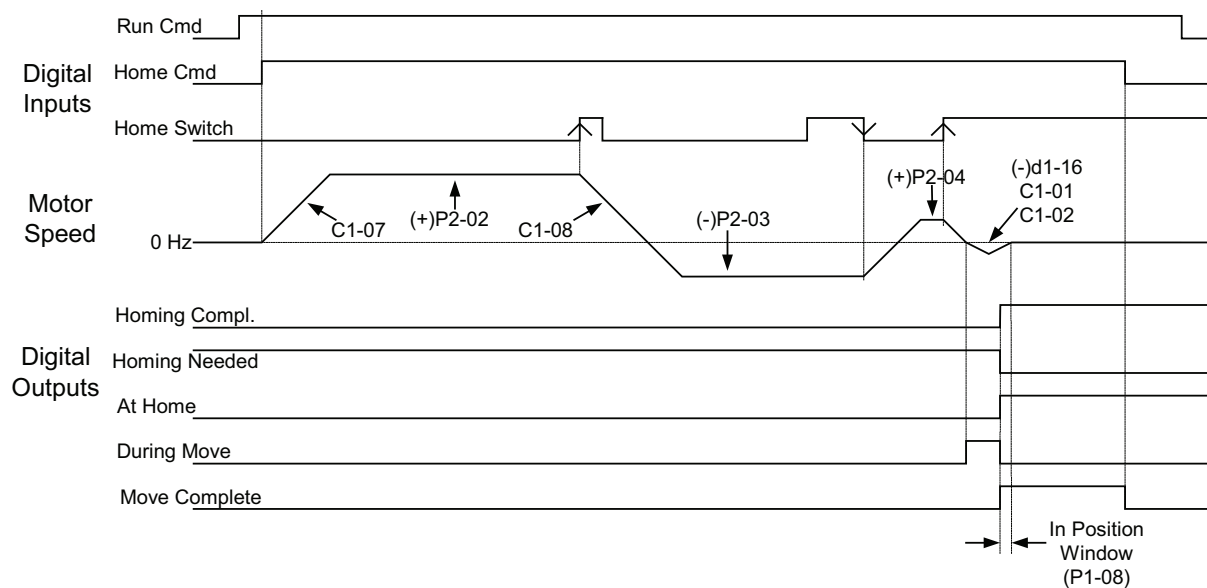

Figure 15 Home Positive with Backup Timing Chart (P2-01=3)

## 5 Function Description

### Home Negative with Marker

The drive will proceed in the negative (reverse) direction at the homing speed when the *home command* input is closed and a run command is issued. When the drive sees the leading edge of the home switch, it continues in reverse and starts looking for a marker pulse from the encoder. As soon as the drive receives the marker pulse, it records the position as home then decelerates using the decel rate specified in parameter C1-08. The drive then performs a move to *home + home offset*.

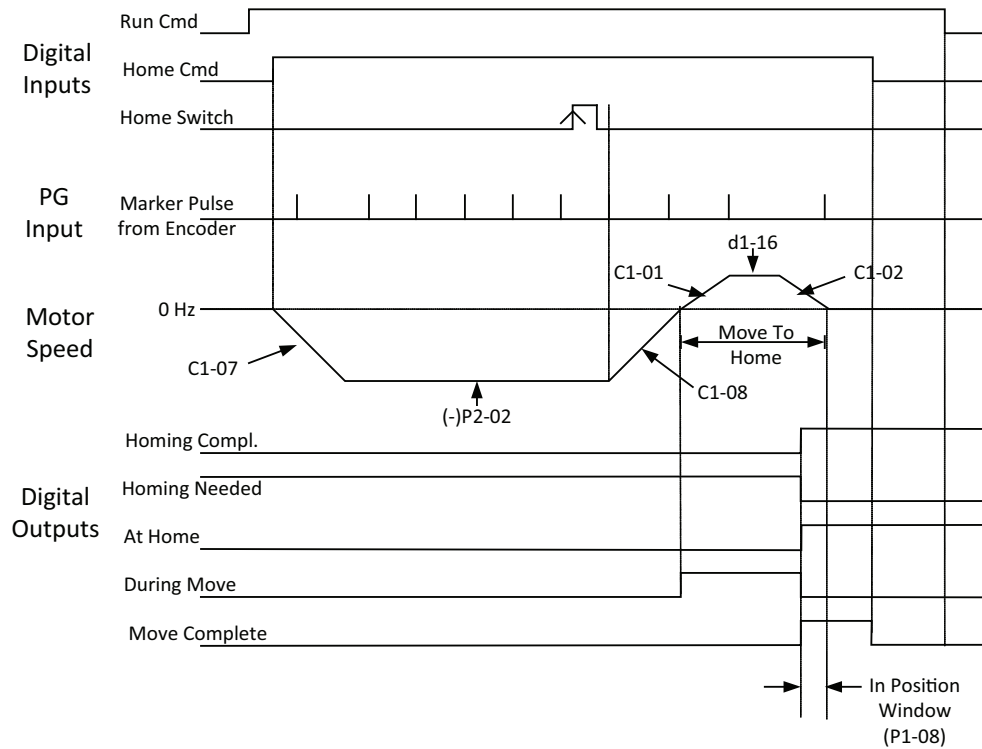

Figure 16 Home Negative with Marker Pulse Timing Chart (P2-01=4)



### Home Positive with Marker

Home positive with marker uses the same sequence as *Home negative with marker*, but the drive proceeds in the positive (forward) direction at the homing speed.

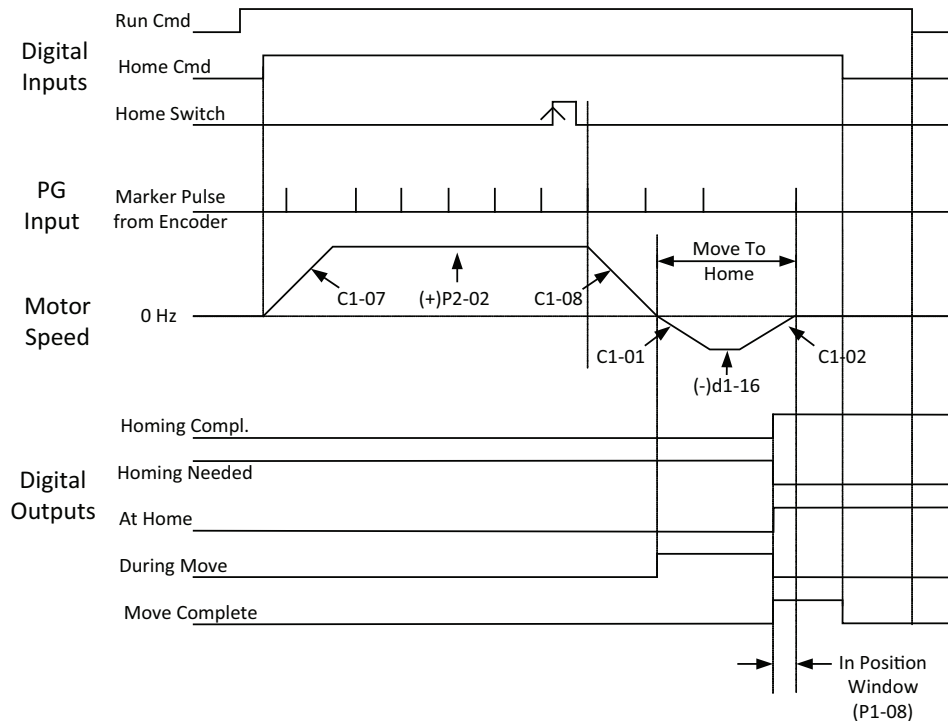

Figure 17 Home Positive with Marker Pulse Timing Chart (P2-01=5)

### Manual Home

Regardless of what position the drive is in when a rising edge of the home switch is detected, it is considered home when this homing method is selected. A *move to home at end of homing routine* is not performed in this mode. If a rising edge of the home switch is detected during a move, the position at the rising edge becomes the new home and the move is canceled.

### Home Offset

Sometimes it is desirable to have the home (zero) position at a different place than the home switch. The home offset parameter stores the distance between the home switch position and the desired actual home position.

### Move to Home at End of Routine

The drive completes a move to the newly found home position (home switch + home offset) when a homing routine is complete. The speed of the move is determined by parameter d1-16, and uses parameters C1-01 and C1-02 as the accel and decel rates. The *homing needed* and *home complete* digital outputs will change as soon as the move to home is complete.

## 5 Function Description

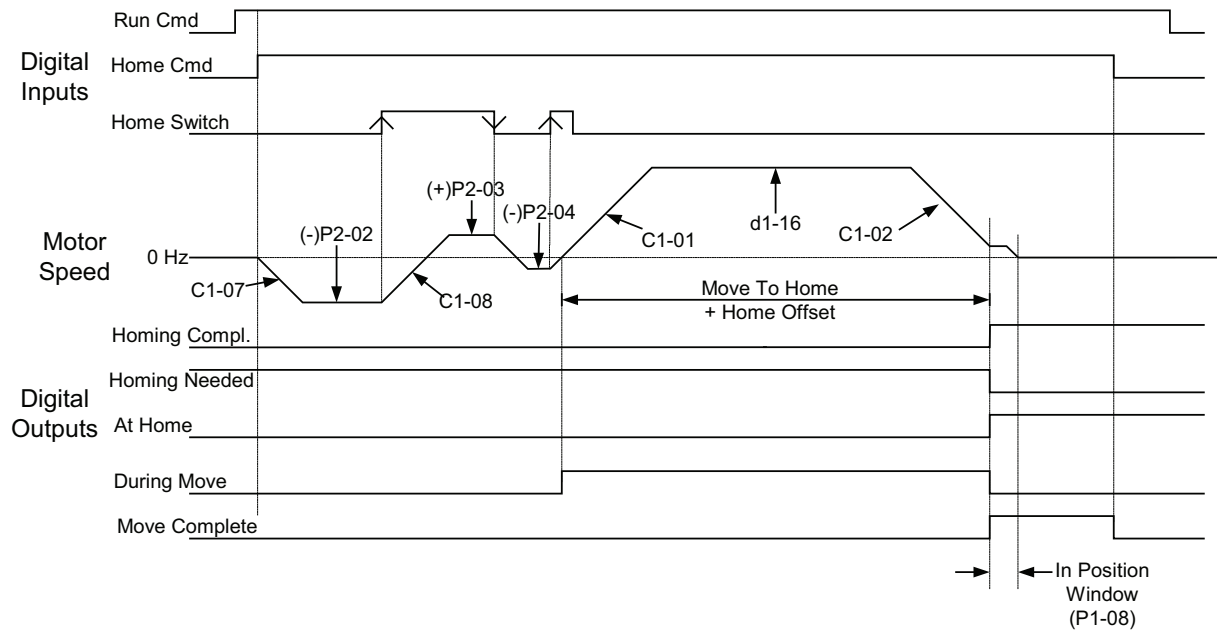

Figure 18 Home Negative with Backup Plus Home Offset (P2-01=1 and P2-06 > 0)

### Already On Home Switch

If a homing sequence is initiated the home switch is already activated, the drive will back off of the home switch then proceed with the normal homing sequence. If the homing type is either *Home Positive w/Backup* or *Home Negative w/Backup*, an abbreviated homing routine is run instead.

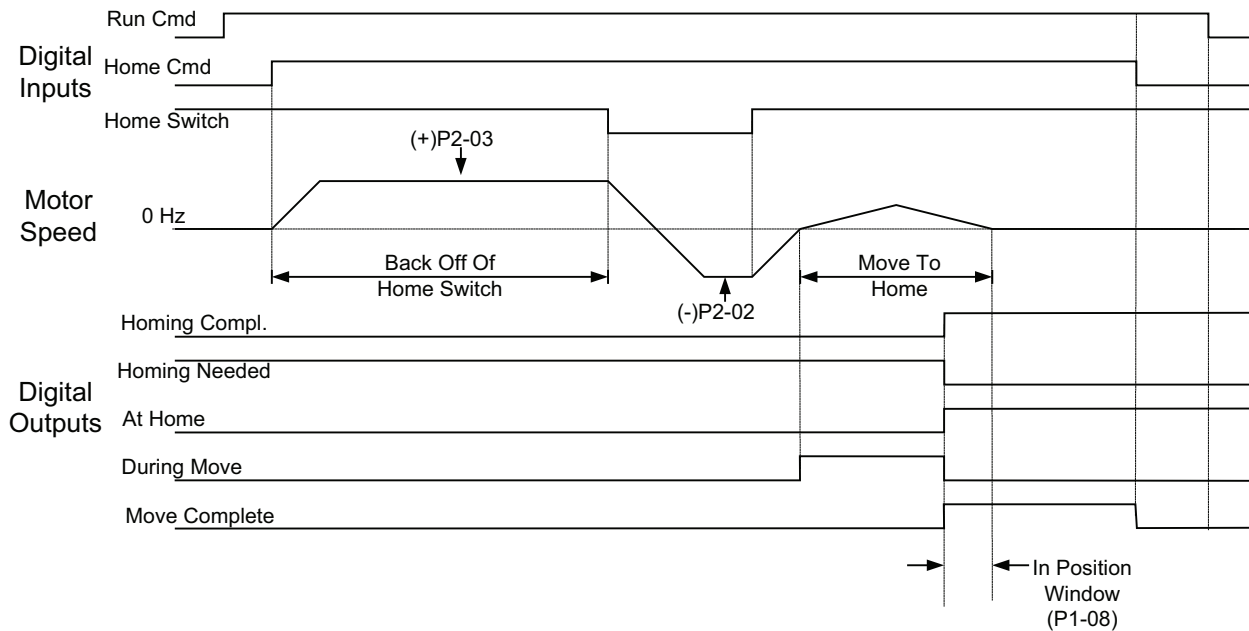

Figure 19 Home Negative Starting on Home Switch (P2-01=0)

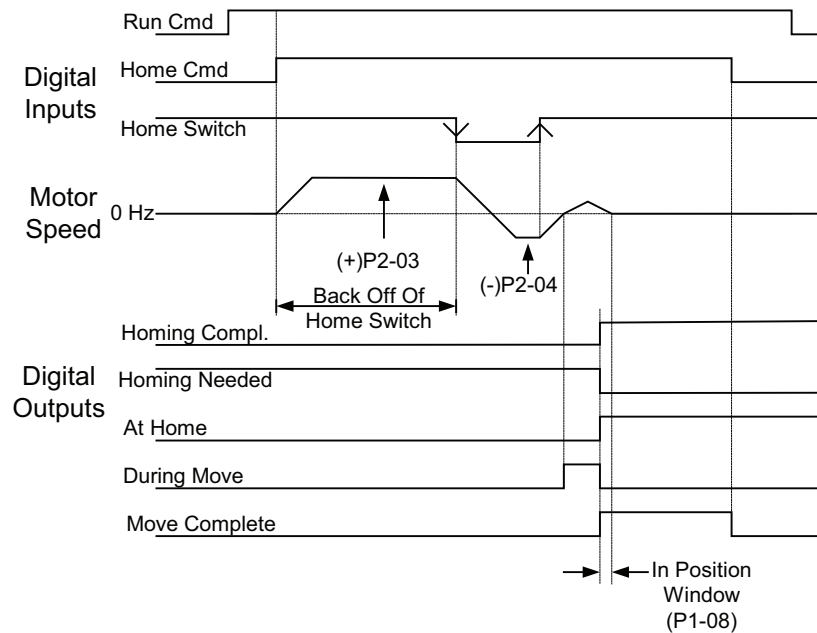

Figure 20 Home Negative with Backup Starting on Home Switch (P2-01=1)

### Homing When Reverse Operation is Disabled

Homing can be affected whenever reverse operation is prohibited (b1-04 = 1). The only homing routines that could be effectively used in under these conditions would be *home forward* and *home forward with marker*. If any other homing type is selected when reverse is disabled, the homing routine will never complete. Normally, when the home switch is activated at the beginning of a homing routine, the drive would back-up off of the home switch. Since backing up is not allowed, the drive will move forward until the next leading edge of the home switch is encountered. [Figure 21](#) represents a home positive timing chart, reverse prohibited, starting on home switch with relative or relative with memory motion type.

If motion type is *Relative* or *Relative w/memory* (P1-01 = 3 or 4) when the rising edge of the home switch is encountered, the drive simply ramps to stop and does not attempt to *move to home*, but instead simply records the *home* position.

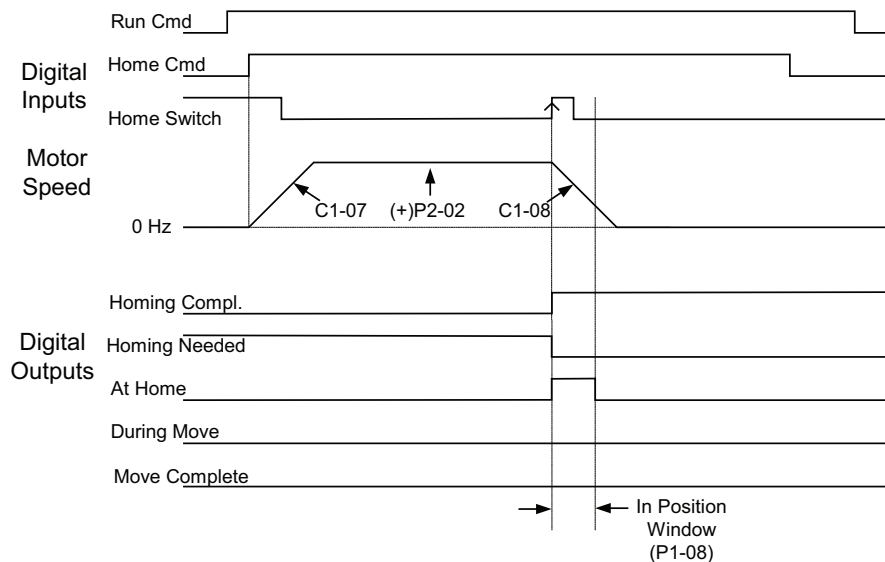

Figure 21 Home Positive Timing Chart, Reverse prohibit, Starting on home switch, Relative or relative with memory motion type. (P2-01=2, b1-04=1)

## 5 Function Description

### Homing When Using an Absolute Incremental Encoder

This software was designed around a TR Electronic brand encoder model #: CD65M-G/S-4096/4096-D23BB-R10NR/N7. Please consult Yaskawa if another brand/model number of encoder is used. When P3-01 = 3 or 4 (Absolute Incremental Encoder), and when the drive is first powered up, it reads the actual position from the serial encoder as follows:

1. Homing begins by the drive closing its *Position Request* output to the encoder using the analog output on terminal FM or AM. This will occur automatically at drive power up or when the *Home Command* digital input is closed.
2. The encoder responds by closing its *Drive Disable* output to the Drive. This signal is run into the analog input terminal A2 or A3. The drive will not operate as long as the *Drive Disable* is high, as the encoder will not work in its incremental mode. The drive will then clear its pulse counter registers. At this time, the *SENCR-Serial Encoder Reading* warning will flash on the display.
3. When the drive is ready to begin counting its absolute position, it opens the *Position Request* output to the encoder. The encoder will output its absolute position by sending the number pulses it is from its zero count. The drive will count the pulses in quadrature. The drive will also monitor the direction (phase) of the A and B channels. During the sending of the absolute position, if the encoder is rotated, the counting procedure will need to be re-run so that the encoder can update the new position, because the encoder will send the position it is in at the beginning of the procedure. It does not add or remove pulses during the pulsing procedure.
4. The encoder will open its *Drive Disable* output telling the drive to use the pulse count at that time as the absolute position when the encoder has relayed its exact position to the drive. The drive will clear the base-block and begin looking at the encoder for incremental feedback.

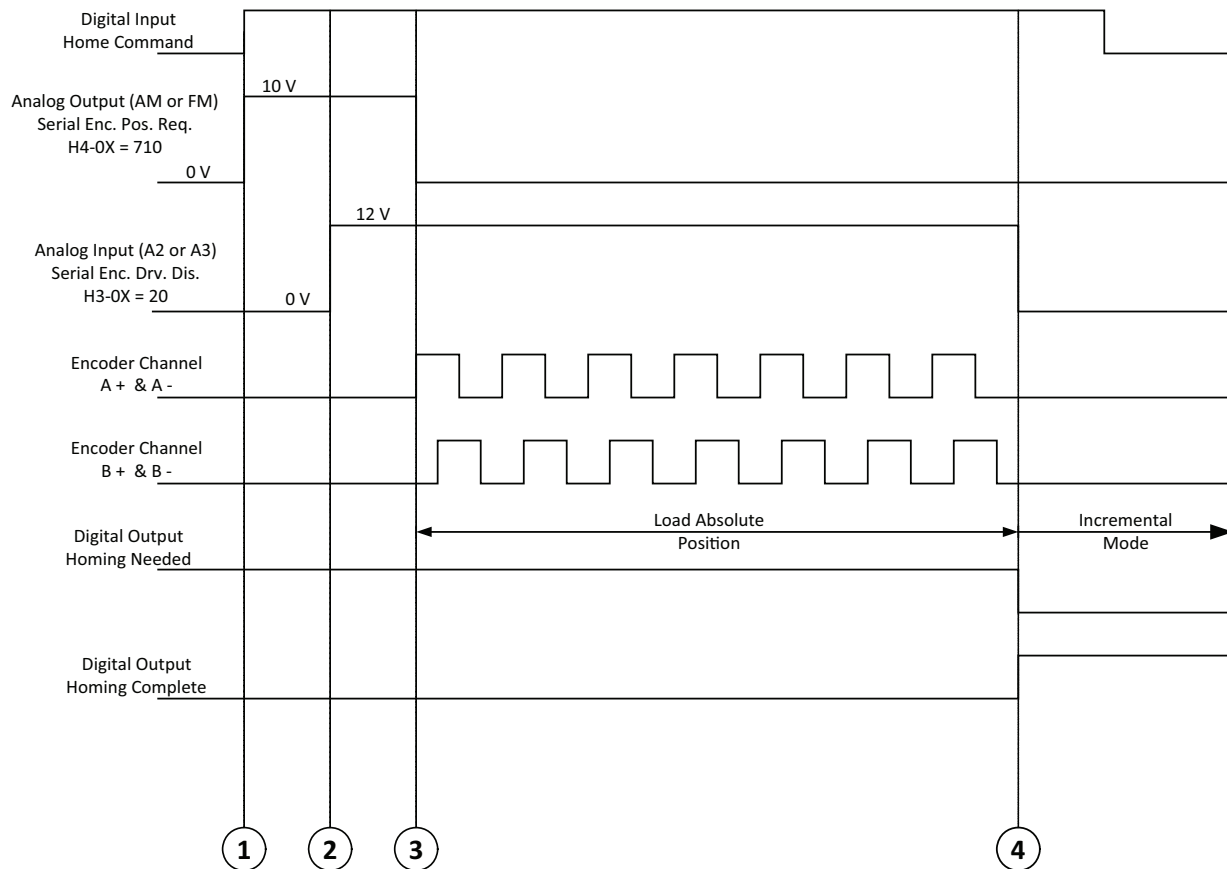

Figure 22 Absolute Incremental Encoder Homing Routine

## ■ Learn Mode

### Digital Preset Position Learn Mode

In order for the drive to record the actual position of the home switch, begin by performing a homing routine. Select the preset position to be learned using the multi-function inputs listed in [Table 9](#). Next, jog the machine into position. Close the *Learn* digital input for more than 1 second.

Avoid excessive use of the learn mode, as the drive's EEPROM can only be written to 100,000 times.

- Note:**
1. If the home offset is utilized, it must to be set prior to using digital preset learn
  2. If using any form of serial communications, when the learn function is used, all parameters that were changed using the RAM ENTER (910h) command are written to EEPROM when the learn function is used.

## ■ Motion Control Disable

If the motion control is disabled, either by setting P1-01 = 0, or by closing the *Motion Disable* digital input, the drive will respond like a drive with standard software installed. Homing will again be required when motion-control is re-enabled.

The maximum distance from home would be +/-  $10^9$  encoder quadrature counts. The home offset also has to be taken into account for this calculation. The above number, using a 1024 PPR encoder, would result in 244,140 motor revolutions, which is about 135 minutes of run time @ 1800 RPM.

Normal drive frequency references will override the motion control software, including jog forward and jog reverse. The drive will still track position when the frequency reference is overridden. If the motion control software is overridden with a jog or other frequency reference when in the middle of a move, the move is canceled and the drive ramps to the new reference. If the position of the drive is too far from home (exceeds internal limits), the drive will need to be re-homed before any moves will be allowed.

## ■ Overtravel

The overtravel multi-function inputs are active only when the motion control is NOT disabled (P1-01 = 0 or by Multi-function Input). If an overtravel switch is activated during a homing routine or a move, the drive will simply decelerate to zero speed and display an overtravel warning. When an overtravel input is active and the overtravel warning is displayed, the *home complete* output will be removed and additional home or move commands are ignored. The drive must be moved out of the overtravel condition manually by using the Jog Fwd or Jog Rev Multi-function Inputs. If the motion type and/or encoder type requires a home, the drive will have to be re-homed after the overtravel has been cleared. The *Learning* function is also disabled during the overtravel condition.

## 5 Function Description

### ■ Pre-Action

The Pre-Action function allows a digital output to indicate when the machine is a given distance (set by P2-08) from its destination during a move. The *Pre Action* digital output (H2-0□ = 46) closes when the distance from commanded destination is less than distance indicated in parameter P2-08 and there if is a move going on. It will open when the distance from commanded destination is less than the in position window (P1-08) or the move is canceled.

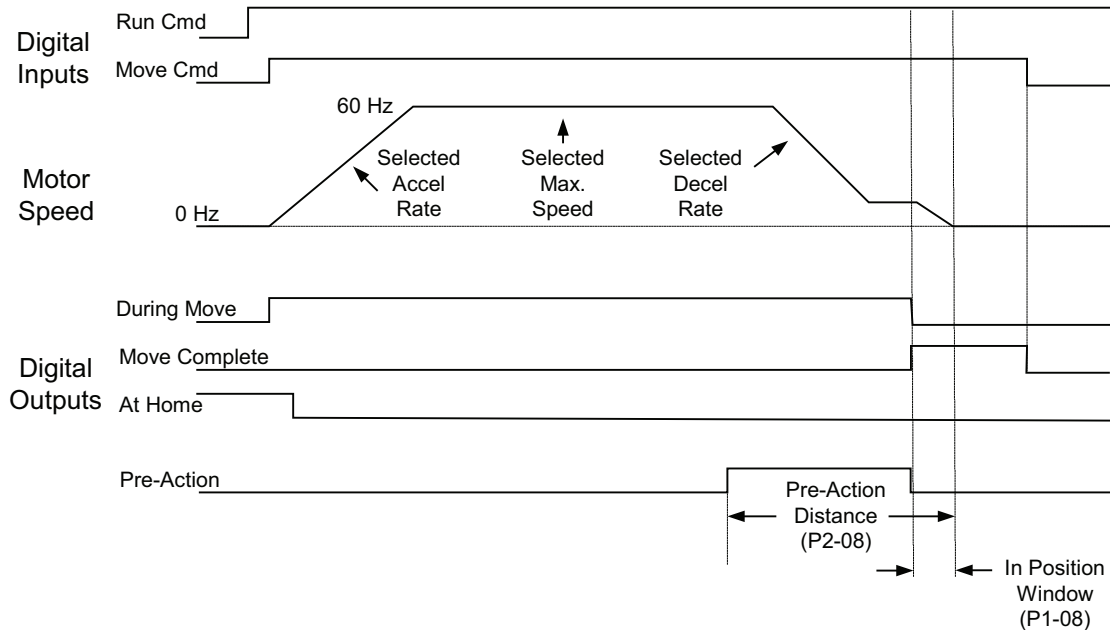

Figure 23 Pre-Action Digital Output

## 6 Absolute Encoder Specifications

### ◆ Absolute Encoder Applications Considerations

- Up to 18 bits of gray code information can be interfaced to the drive.
- Available only for Linear Absolute applications.
- Requires a DI-A3 option card installed at CN5-B or CN5-A on the drive.
- In addition to the gray code encoder, requires a separate motor-mounted incremental encoder AND a PG-X3/PG-B3 option card installed at CN5-C on the drive.
- Logic Levels: +24 Vdc (true) and 0 Vdc (false).
- Gray code encoder must be capable of sinking current on its outputs.
- Mountable directly on machine or on motor (gear ratio available).
- Tested with a Dynapar ai2512122B121 multi-turn gray code encoder. This encoder has 12 bits of resolution per revolution, and 12 bits of revolutions.
- External power supply required to power absolute encoder.
- Position reference for any move will be clamped between 0 counts and 262,143 counts when a Gray Code encoder is enabled. If the encoder is manually moved out of this range (ie below zero or above 262,143 counts), the position tracking will not work correctly. It is *strongly* recommended to keep all moves at least 500 counts away from these limits in case of overshoot during a move.

**Table 16 Absolute Encoder Wire Color Chart For Dynapar PN ai2512122B121**

Signal	Color	Pin	
Counts	S0	Brown	2
	S1	Green	21
	S2	Yellow	3
	S3	Grey	22
	S4	Pink	4
	S5	Violet	23
	S6	Grey / Pink	5
	S7	Red / Blue	24
	S8	White / Green	6
	S9	Brown / Green	25
	S10	White / Yellow	7
	S11	Yellow / Brown	26
Revolutions	M0	White / Grey	8
	M1	Grey / Brown	27
	M2	White / Pink	9
	M3	Pink / Brown	28
	M4	White / Blue	14
	M5	Brown / Blue	33
	M6	White / Red	15
	M7	Brown / Red	34
	M8	White / Black	16
	M9	Brown / Black	35
	M10	Grey / Green	17
	M11	Yellow / Grey	36
Misc. Control	Alarm	Pink / Green	18
	Direction	Yellow / Pink	10
	Latch	Green / Blue	30
	Tristate	Yellow / Blue	12

## 6 Absolute Encoder Specifications

Signal		Color		Pin
Power	Vcc	Red / Blue		13
	Vcc	White		31
	Common	Blue		1
	Common	Black		20

**Table 17 Wiring Table-DI-A3 option card to Absolute Gray Code Encoder (Dynapar PN ai2512122B121)**

DI-A3 Option Card		More Resolution <-----> More Revolutions									
		Revolutions: 64		Revolutions: 256		Revolutions: 512		Revolutions: 1024		Revolutions: 4096	
		Counts/Revolution: 4096		Counts/Revolution: 1024		Counts/Revolution: 512		Counts/Revolution: 256		Counts/Revolution: 64	
		P3-02=4096		P3-02=1024		P3-02=512		P3-02=256		P3-02=64	
Function	Terminal	Signal	Wire Color	Signal	Wire Color	Signal	Wire Color	Signal	Wire Color	Signal	Wire Color
Bit 0	TB2 – D0	S0	Brown	S2	Yellow	S3	Grey	S4	Pink	S6	Grey/Pink
Bit 1	TB2 – D1	S1	Green	S3	Grey	S4	Pink	S5	Violet	S7	Red/Blue
Bit 2	TB2 – D2	S2	Yellow	S4	Pink	S5	Violet	S6	Grey/Pink	S8	White/Green
Bit 3	TB2 – D3	S3	Grey	S5	Violet	S6	Grey/Pink	S7	Red/Blue	S9	Brown/Green
Bit 4	TB2 – D4	S4	Pink	S6	Grey/Pink	S7	Red/Blue	S8	White/Green	S10	White/ Yellow
Bit 5	TB2 – D5	S5	Violet	S7	Red/Blue	S8	White/Green	S9	Brown/ Green	S11	Yellow/ Brown
Bit 6	TB2 – D6	S6	Grey/Pink	S8	White/Green	S9	Brown/Green	S10	White/ Yellow	M0	White/Grey
Bit 7	TB2 – D7	S7	Red/Blue	S9	Brown/Green	S10	White/Yellow	S11	Yellow/ Brown	M1	Grey/Brown
Bit 8	TB3 – D8	S8	White/Green	S10	White/Yellow	S11	Yellow/Brown	M0	White/ Grey	M2	White/Pink
Bit 9	TB3 – D9	S9	Brown/Green	S11	Yellow/ Brown	M0	White/Grey	M1	Grey/ Brown	M3	Pink/Brown
Bit 10	TB3 – DA	S10	White/Yellow	M0	White/Grey	M1	Grey/Brown	M2	White/ Pink	M4	White/Blue
Bit 11	TB3 – DB	S11	Yellow/Brown	M1	Grey/Brown	M2	White/Pink	M3	Pink/Brown	M5	Brown/Blue
Bit 12	TB3 – DC	M0	White/Grey	M2	White/Pink	M3	Pink/Brown	M4	White/Blue	M6	White/Red
Bit 13	TB3 – DD	M1	Grey/Brown	M3	Pink/Brown	M4	White/Blue	M5	Brown/Blue	M7	Brown/Red
Bit 14	TB3 – DE	M2	White/Pink	M4	White/Blue	M5	Brown/Blue	M6	White/Red	M8	White/Black
Bit 15	TB3 – DF	M3	Pink/Brown	M5	Brown/Blue	M6	White/Red	M7	Brown/Red	M9	Brown/Black
Bit 16	TB1 – SI	M4	White/Blue	M6	White/Red	M7	Brown/Red	M8	White/Black	M10	Grey/Green
Bit 17	TB1 – SE	M5	Brown/Blue	M7	Brown/Red	M8	White/Black	M9	Brown/ Black	M11	Yellow/Grey
Common	TB1 – FE	Common	Blue	Common	Blue	Common	Blue	Common	Blue	Common	Blue

**Note:** An external +24V power supply is required when using with this encoder. The power supply is connected as follows: +24 V to Red and 0 V to Black.



**This Page Intentionally Blank**

## 7 Revision History

The revision dates and the numbers of the revised manuals appear on the bottom of the back cover.

MANUAL NO. TM.A1000SW.056  
 Published in U.S.A. August 2011 09-11   
 Date of publication      Date of original publication      Revision number

Date of Publication	Revision Number	Section	Revised Content
May 2014	2	5	Figures 4 through 8, revised.
September 2013	1	Various	Corrected instances of superscript appearing as non-superscript characters throughout.
August 2013	-	-	First Release



# YASKAWA AC Drive - A1000

## Motion Control

### Custom Software Supplement

---

**YASKAWA AMERICA, INC.**

2121 Norman Drive South, Waukegan, IL 60085, U.S.A.  
Phone: (800) YASKAWA (927-5292) or 1-847-887-7000 Fax: 1-847-887-7310  
<http://www.yaskawa.com>

**DRIVE CENTER (INVERTER PLANT)**

2-13-1, Nishimiyaichi, Yukuhashi, Fukuoka, 824-8511, Japan  
Phone: 81-930-25-3844 Fax: 81-930-25-4369  
<http://www.yaskawa.co.jp>

**YASKAWA ELECTRIC CORPORATION**

New Pier Takeshiba South Tower, 1-16-1, Kaigan, Minatoku, Tokyo, 105-6891, Japan  
Phone: 81-3-5402-4502 Fax: 81-3-5402-4580  
<http://www.yaskawa.co.jp>

**YASKAWA ELÉTRICO DO BRASIL LTDA.**

Avenda Fagundes Filho, 620 Bairro Saude, São Paulo, SP04304-000, Brasil  
Phone: 55-11-3585-1100 Fax: 55-11-5581-8795  
<http://www.yaskawa.com.br>

**YASKAWA EUROPE GmbH**

Hauptstrasse 185, 65760 Eschborn, Germany  
Phone: 49-6196-569-300 Fax: 49-6196-569-398  
<http://www.yaskawa.eu.com>

**YASKAWA ELECTRIC UK LTD.**

1 Hunt Hill Orchardton Woods, Cumbernauld, G68 9LF, United Kingdom  
Phone: 44-1236-735000 Fax: 44-1236-458182  
<http://www.yaskawa.co.uk>

**YASKAWA ELECTRIC KOREA CORPORATION**

7F, Doore Bldg. 24, Yeoido-dong, Yeoungdungpo-gu, Seoul, 150-877, Korea  
Phone: 82-2-784-7844 Fax: 82-2-784-8495  
<http://www.yaskawa.co.kr>

**YASKAWA ELECTRIC (SINGAPORE) PTE. LTD.**

151 Lorong Chuan, #04-01, New Tech Park, 556741, Singapore  
Phone: 65-6282-3003 Fax: 65-6289-3003  
<http://www.yaskawa.com.sg>

**YASKAWA ELECTRIC (SHANGHAI) CO., LTD.**

No. 18 Xizang Zhong Road, 17F, Harbour Ring Plaza, Shanghai, 200001, China  
Phone: 86-21-5385-2200 Fax: 86-21-5385-3299  
<http://www.yaskawa.com.cn>

**YASKAWA ELECTRIC (SHANGHAI) CO., LTD. BEIJING OFFICE**

Room 1011, Tower W3 Oriental Plaza, No. 1 East Chang An Ave.,  
Dong Cheng District, Beijing, 100738, China  
Phone: 86-10-8518-4086 Fax: 86-10-8518-4082

**YASKAWA ELECTRIC TAIWAN CORPORATION**

9F, 16, Nanking E. Rd., Sec. 3, Taipei, 104, Taiwan  
Phone: 886-2-2502-5003 Fax: 886-2-2505-1280



YASKAWA AMERICA, INC.

In the event that the end user of this product is to be the military and said product is to be employed in any weapons systems or the manufacture thereof, the export will fall under the relevant regulations as stipulated in the Foreign Exchange and Foreign Trade Regulations. Therefore, be sure to follow all procedures and submit all relevant documentation according to any and all rules, regulations and laws that may apply.

Specifications are subject to change without notice for ongoing product modifications and improvements.

© 2013 YASKAWA AMERICA, INC. All rights reserved.



TM.A1000SW.117

MANUAL NO. TM.A1000SW.117

Published in U.S.A. May 2014 13-8 <2>