

INDEX

UNILINE - THE ONLY CHOICE	B5
FAMILIES	B6
WHICH ACTUATOR TO CHOOSE (performance according to applied load type).....	B9
LOAD CAPACITIES	B10
A40	B11
A55	B12
C55	B13
E55	B14
A75	B15
C75	B16
E75	B17
ED75	B18
VERSION “L” (Long trolley)	B19
VERSION “D” (Double trolley)	B20
VERSION “H” (Slave unit)	B21
VERIFICATION UNDER STATIC LOAD	B22
LIFETIME	B23
CALCULATION METHODS (M_z and M_y for long and double trolley versions, motor torque calculation).....	B24
MOUNTING CONFIGURATIONS AND INSTRUCTIONS	B25
MOTOR/GEARBOX CONNECTION	B30
BELT TENSIONING	B31
LUBRICATION	B32
MOUNTING ACCESSORIES (motor interface plates, mounting plates and mounting blocks, T-nuts).....	B33
OTHER USEFUL INFORMATION	B37

INDEX

LINEAR UNIT A100C.....	B38
DIMENSIONS.....	B39
ATTACHMENTS ON THE SLIDER.....	B39
MOTOR CONNECTIONS (Version A - B).....	B40
NOTES.....	B41
ACCESSORIES.....	B41
TECHNICAL CHARACTERISTICS OF THE STANDARD VERSION.....	B42
SPECIAL VERSION.....	B43
LINEAR UNIT WITH LONG SLIDER (A100C...L).....	B43
LINEAR UNIT WITH TWO SLIDERS (A100C...D).....	B43
ORDER CODES.....	B44

UNILINE - THE ONLY CHOICE

UNILINE is a family of linear actuators designed to facilitate the work of the design engineer. Assembled with only the best components, **UNILINE** actuators are of the highest quality. By specifying a **UNILINE** actuator, the design engineer must no longer spend time selecting, purchasing, and testing various components to provide linear movement. Instead, the designer is free to focus on those other parts of the machine that will set it apart from the competition.

UNILINE's strength resides in the many advantages it offers:

- It is a **complete solution**. Based on the linear rail from the **ROLLON COMPACT RAIL** family mounted in an extruded aluminum-alloy profile, it is compatible with the myriad of standard mounting accessories found in the market;
- It is **versatile**. With many configurations and sizes available, including versions with extra long and/or multiple trolleys;
- It is **smart**. Allowing the designer to spend time elsewhere instead of in the details of the linear motion;
- It is **safe**. With the linear rail and slide placed inside the extrusion, the units easily surpass modern safety norms protecting workers from moving parts;
- It makes **economic sense**. The highest quality components are skillfully assembled and are ready to mount and go;
- It is **esthetically pleasing** in its compact and clean lines;
- It is **rapid** in movement and in its delivery to you;
- It is a **ROLLON** product, which in itself is a **guarantee of quality, timeliness, and service**.



FAMILIES

Below and in the following pages, **ROLLON** presents the physical aspects of its **UNILINE** family of linear actuators for a quick and easy comparison. These pages allow you to have a better idea of which unit best fits your application. Please consult pages B10 - B18 for specific details of each product. For more information, please consult our Application Engineering Department.

“A” FAMILY:

The A's have a COMPACT “T”-rail mounted flat inside the profile. This simple configuration is perfect for most applications.

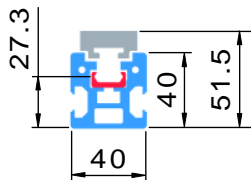

A40

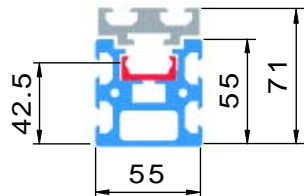

A55

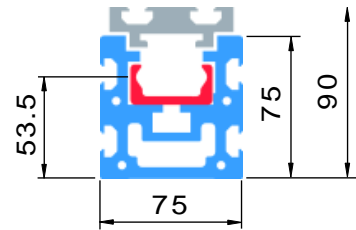

A75

“C” FAMILY:

The C's have a COMPACT “T”-rail mounted face to face with a Compact “U”-rail. This configuration is ideal for vertical or single axis or where great M_y moments are present.

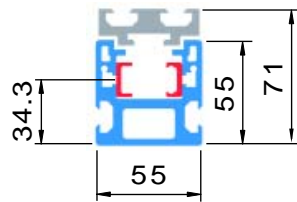

C55

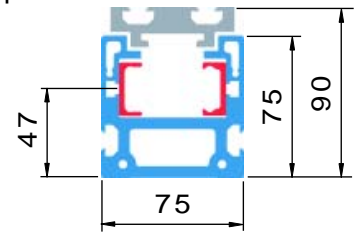

C75

“E” FAMILY:

The E's have a COMPACT “T”-rail mounted flat inside the profile and one Compact “U”-rail mounted externally. This configuration offers superior rigidity and is well suited for single axis applications or where a great M_x moment is present.

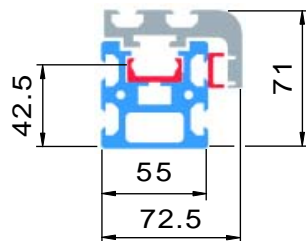

E55

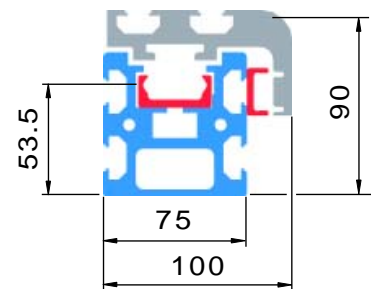

E75

“ED75” FAMILY:

The ED75 have a Compact “U”-rail mounted flat inside the profile and two Compact “U”-rails mounted externally; one on each side. This configuration offers superior rigidity and is well suited for single axis applications or where a great moments are present.

ED75

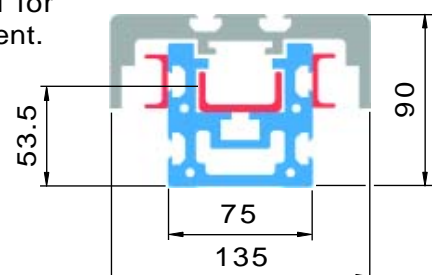

“A” FAMILY:

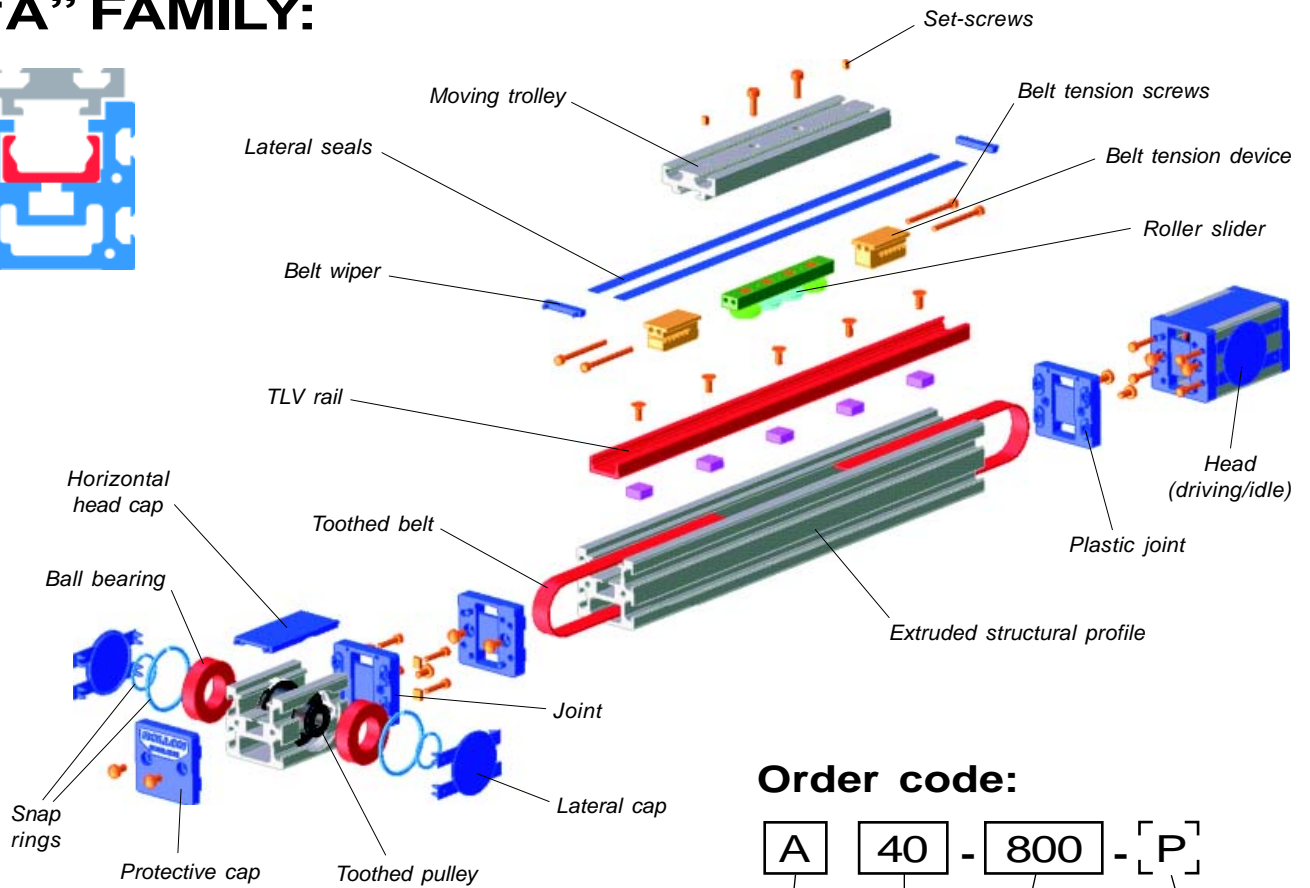

Order code:

A - 40 - 800 - P
 family size stroke version with pulley
 (40, 55, 75) (in mm) shaft housing in inches

“C” FAMILY:

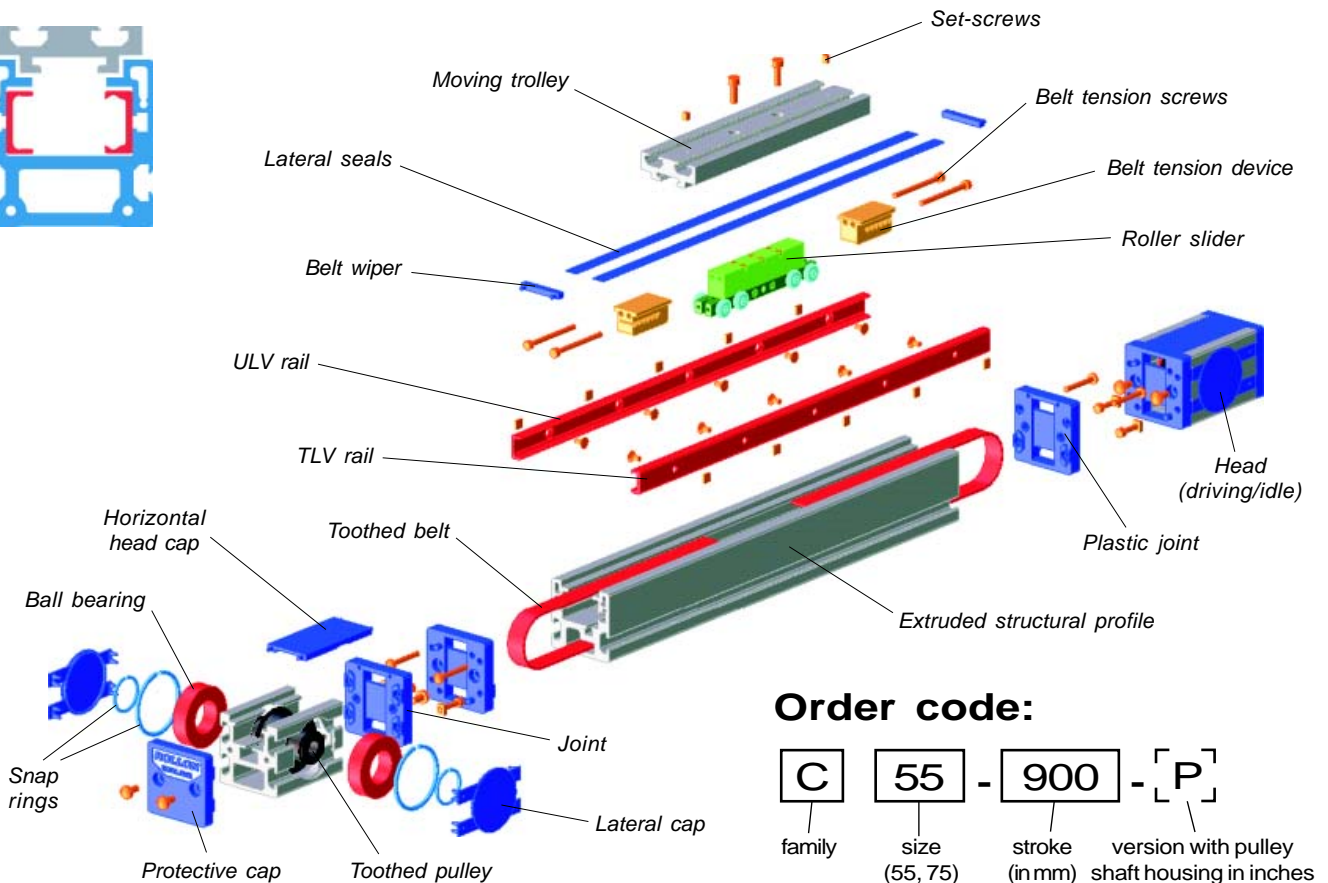
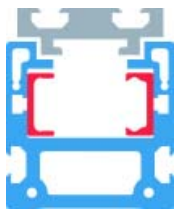

Order code:

C - 55 - 900 - P
 family size stroke version with pulley
 (55, 75) (in mm) shaft housing in inches

“E” FAMILY:

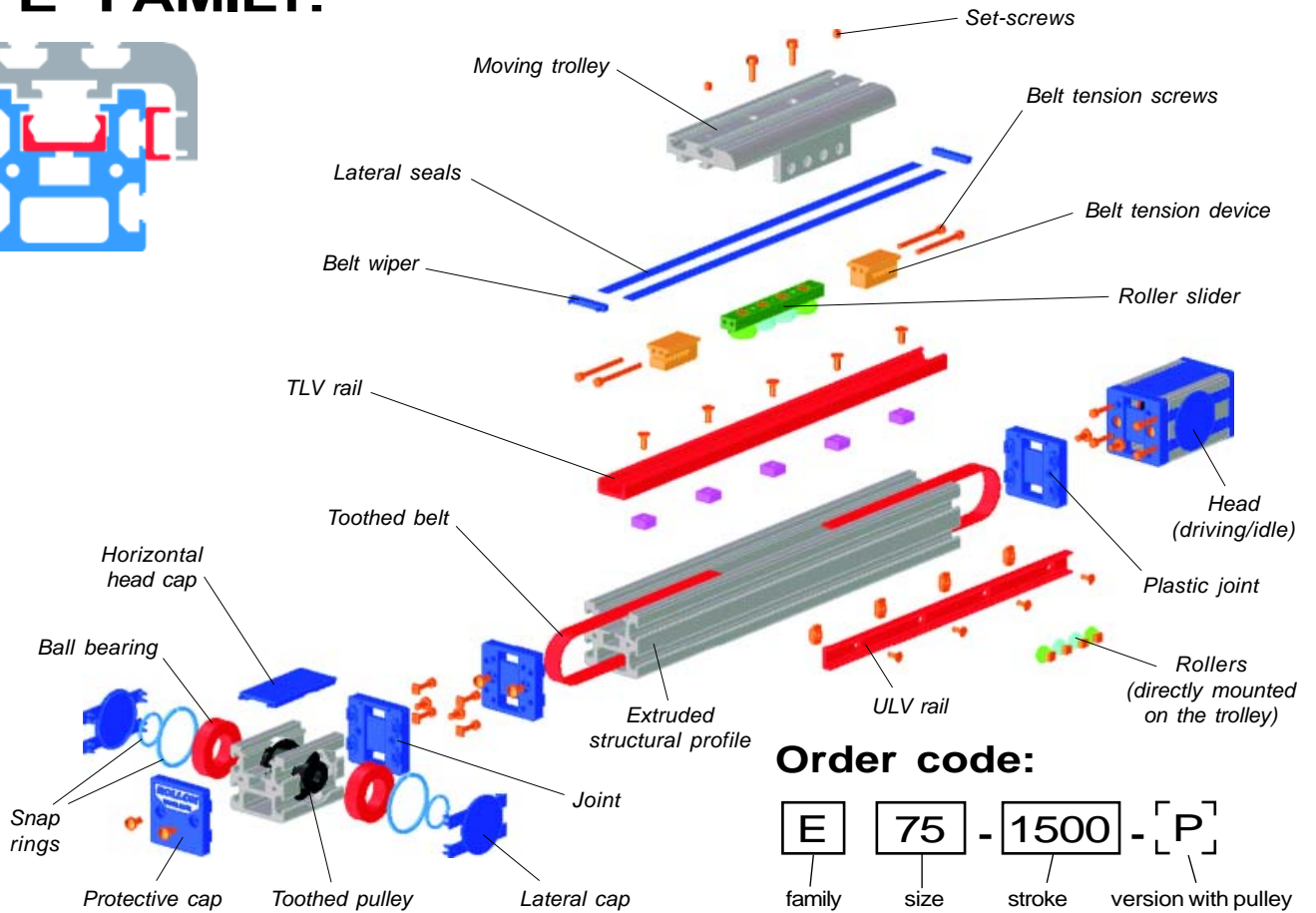
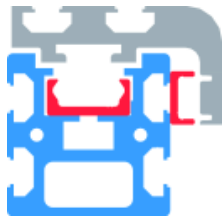

Order code:

E	75	- 1500	- [P]
family	size (55, 75)	stroke (in mm)	version with pulley shaft housing in inches

“ED75” FAMILY:

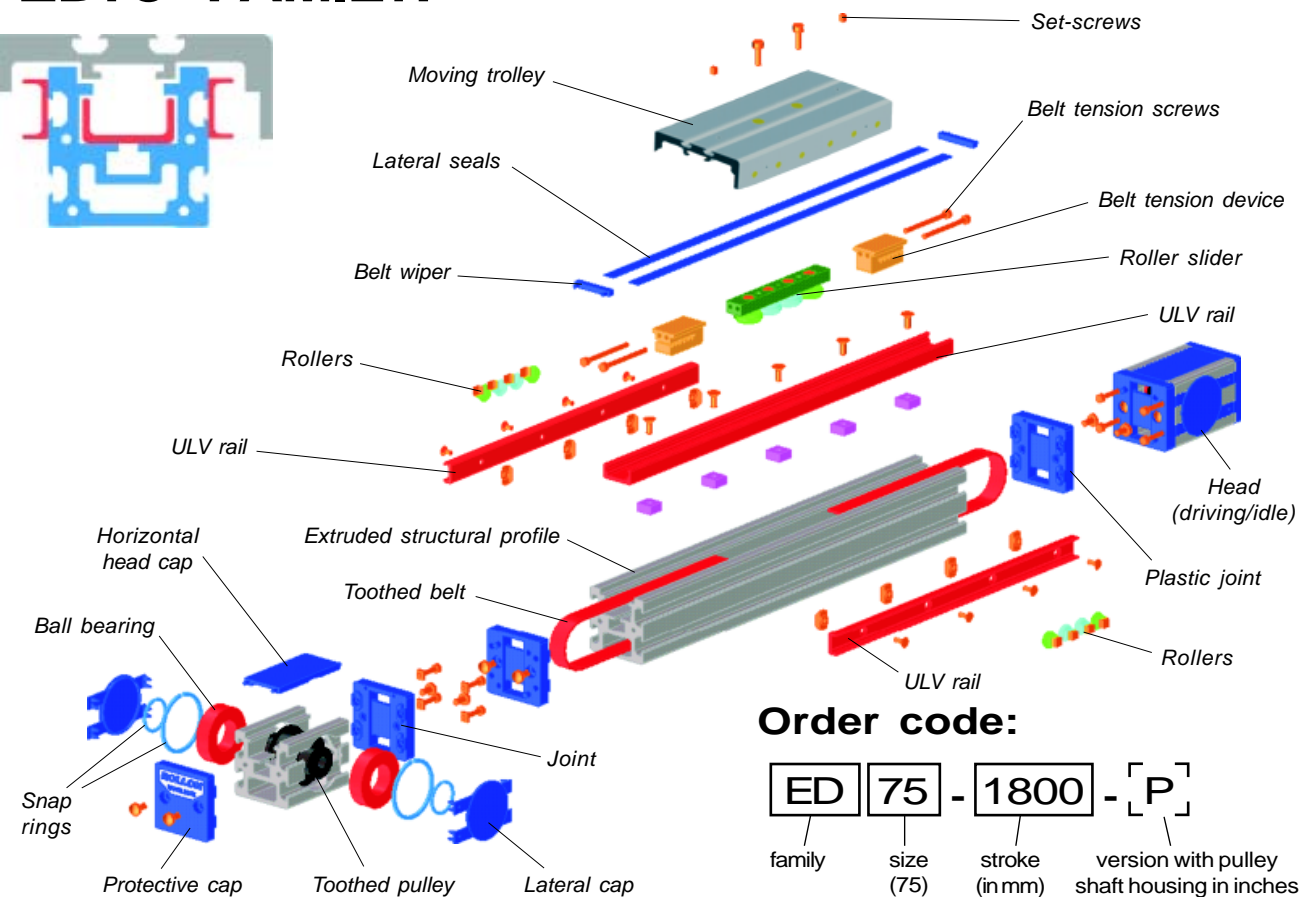
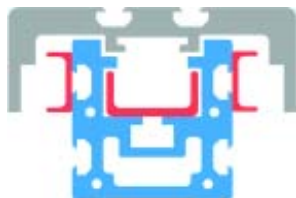

Order code:

ED	75	- 1800	- [P]
family	size (75)	stroke (in mm)	version with pulley shaft housing in inches

WHICH ACTUATOR TO CHOOSE

(PERFORMANCE ACCORDING TO APPLIED LOAD TYPE)

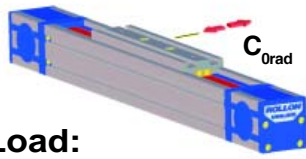

Radial Load:

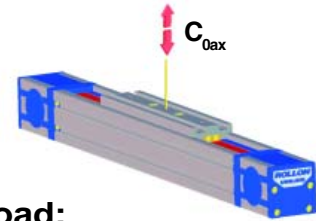
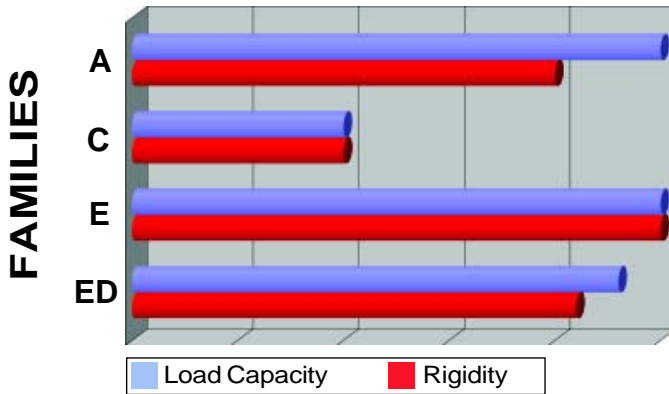

Axial Load:

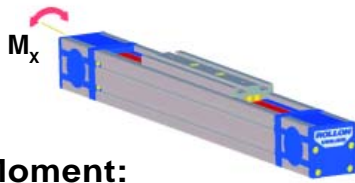
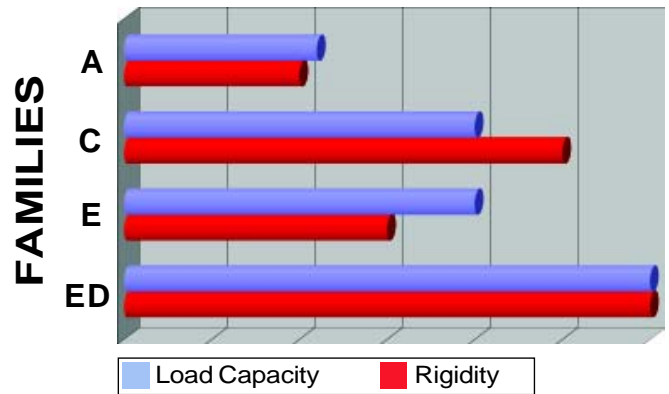

Mx Moment:

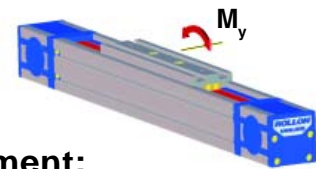
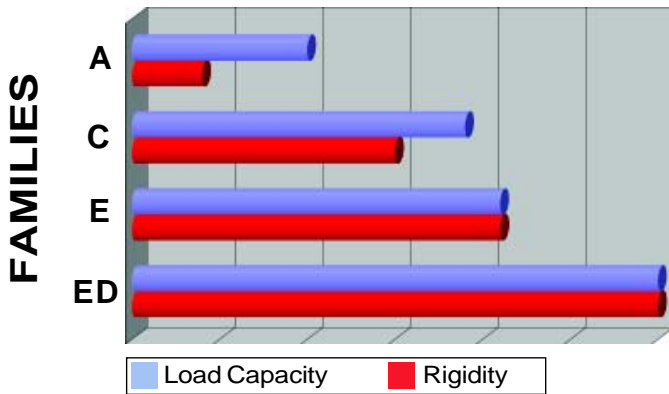

My Moment:

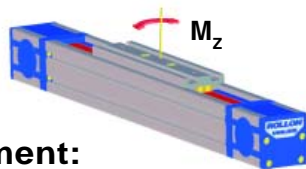
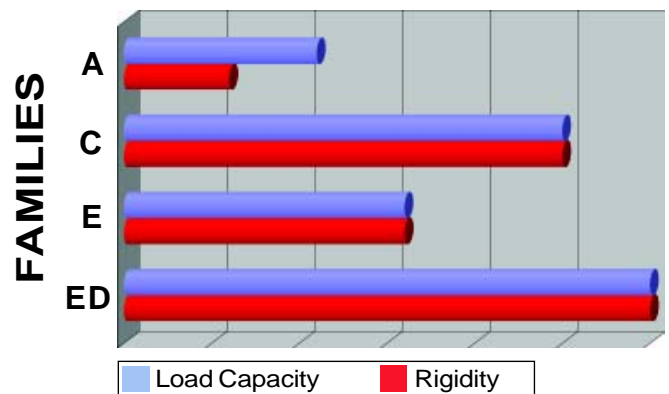

MZ Moment:

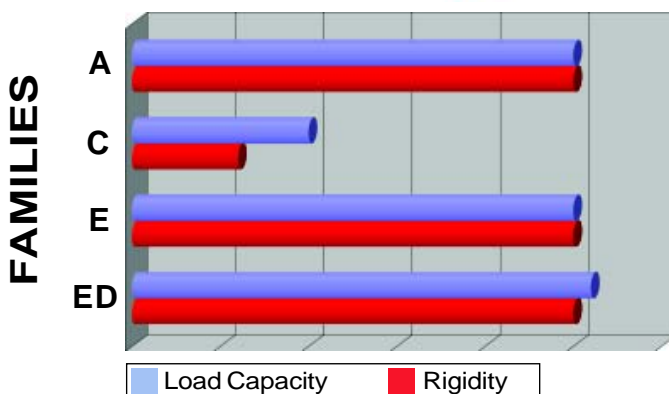

Note: Same size **UNILINE** actuators with loads applied to a single unit were used in these comparisons.

LOAD CAPACITIES

As indicated below, the load capacities refer to the standard product with one trolley. Load capacities of versions with **long** or **double trolleys** are significantly higher (see pages B19-B20). If various forces act contemporarily on a unit, these forces must be taken into consideration when calculating the load capacity. The various loads applied must be compared with the unit's maximum capacities in the respective directions. These ratios must be added together and the sum must never exceed the desired safety factor (see page B22). For more information, contact our Application Engineering Dept.

• “A” FAMILY

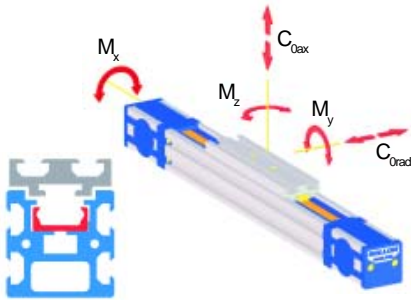

Type	C_{0rad} [N]	C_{0ax} [N]	M_x [Nm]	M_y [Nm]	M_z [Nm]
A40	820	300	2.8	5.6	13.1
A55	2175	750	11.5	21.7	54.4
A75	5500	1855	43.6	81.5	209

Note: The values refer to the standard product with one trolley.

• “C” FAMILY

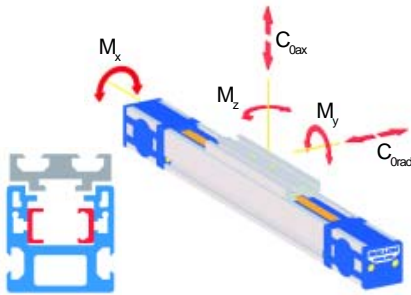

Type	C_{0rad} [N]	C_{0ax} [N]	M_x [Nm]	M_y [Nm]	M_z [Nm]
C55	300	1640	18.5	65.6	11.7
C75	750	4350	85.2	217	36.1

Note: The values refer to the standard product with one trolley.

• “E” FAMILY

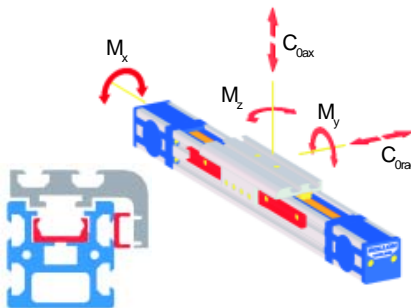

Type	C_{0rad} [N]	C_{0ax} [N]	M_x [Nm]	M_y [Nm]	M_z [Nm]
E55	2175	1500	25.5	43.4	54.4
E75	5500	3710	85.5	163	209

Note: The values refer to the standard product with one trolley.

• “ED75” FAMILY

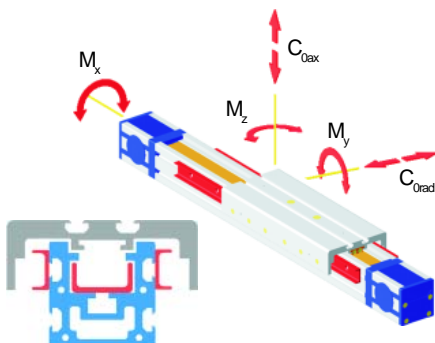

Type	C_{0rad} [N]	C_{0ax} [N]	M_x [Nm]	M_y [Nm]	M_z [Nm]
ED75	5500	8700	400.2	696	240

Note: The values refer to the standard product with one trolley.

A40

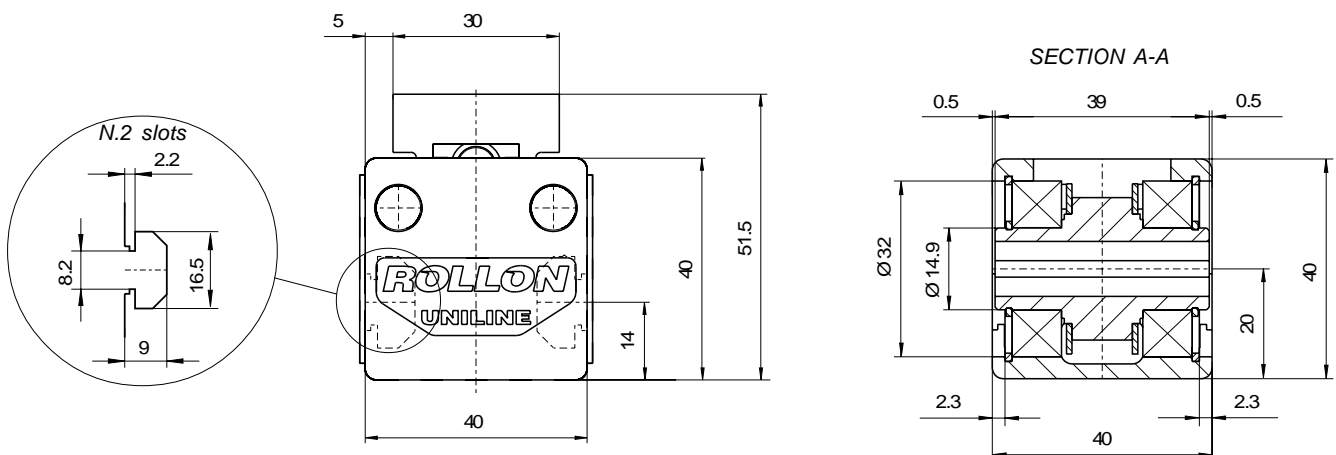
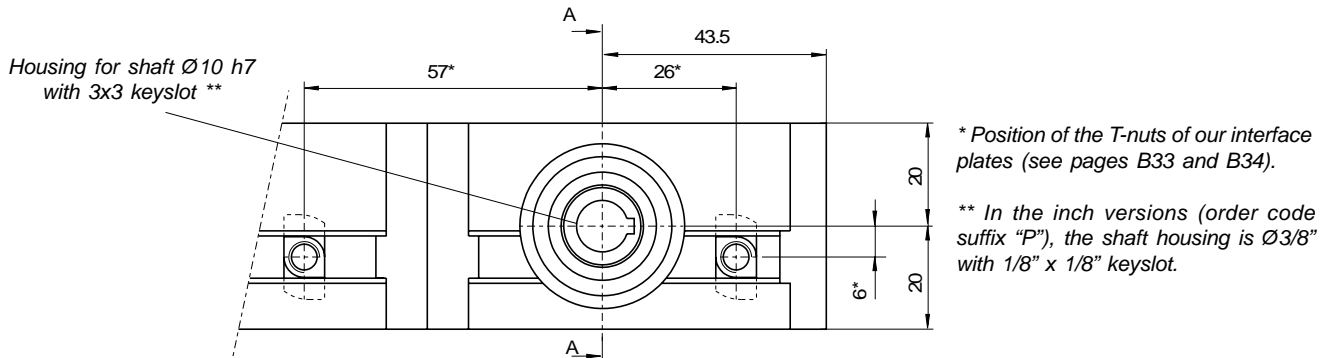
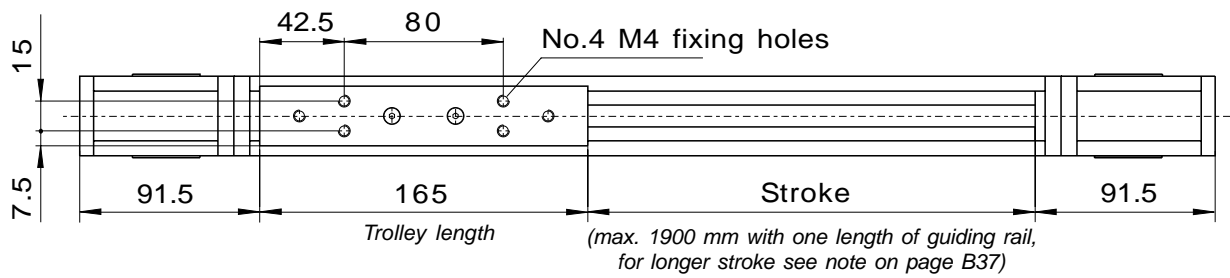

LOAD CAPACITIES

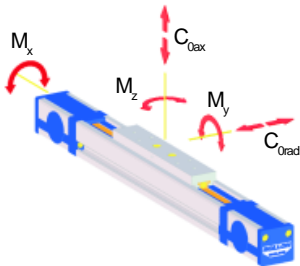

C_{0rad} [N]	C_{0ax} [N]	M_x [Nm]	M_y [Nm]	M_z [Nm]
820	300	2.8	5.6	13.1

Note: radial load C_{0rad} is considered to be applied along the axis of the internal rail (see page B6).

OTHER FEATURES

Moment of inertia I_y [cm ⁴]	12	Type of slider	CSW18 spec. 4 rollers
Moment of inertia I_z [cm ⁴]	13.6	Pitch diameter of pulley [m]	0.02706
Max speed [m/s]	3	Moment of inertia of mass of each pulley [gmm ²]	5055
Weight of unit with stroke zero [g]	1459	Mass of belt [g/m]	41
Weight of unit per meter [g]	3465	Max. Belt Tractive Force F_{max} [N]	875
Mass of slider [g]	220	Standard belt tension [N]	160
Stroke for shaft revolution [mm]	85	Standard starting loadless torque [Nm]	0.14
Type of guiding rail	TLV18	Belt length [m]	2 x stroke (in m)+ 0.515

A55

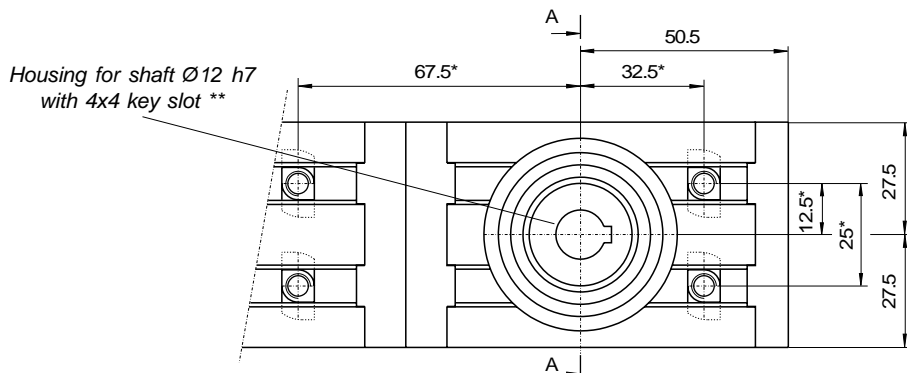
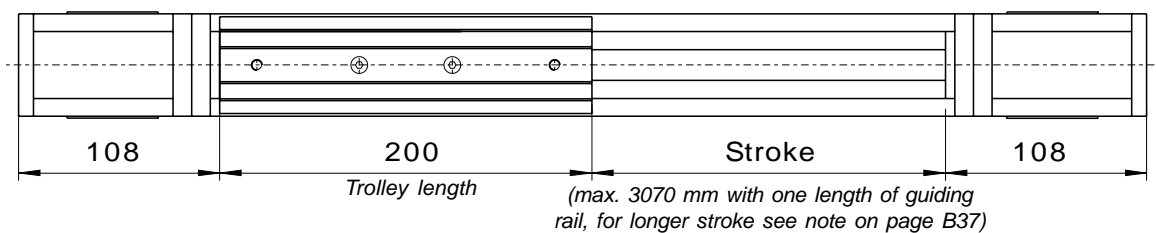

* Position of the T-nuts of our interface plates (see pages B33 and B34).

** In the inch versions (order code suffix "P"), the shaft housing is $\varnothing 1/2$ " with $1/8$ " x $1/8$ " keyslot.

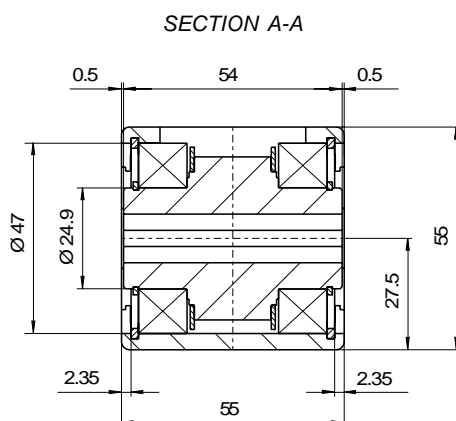
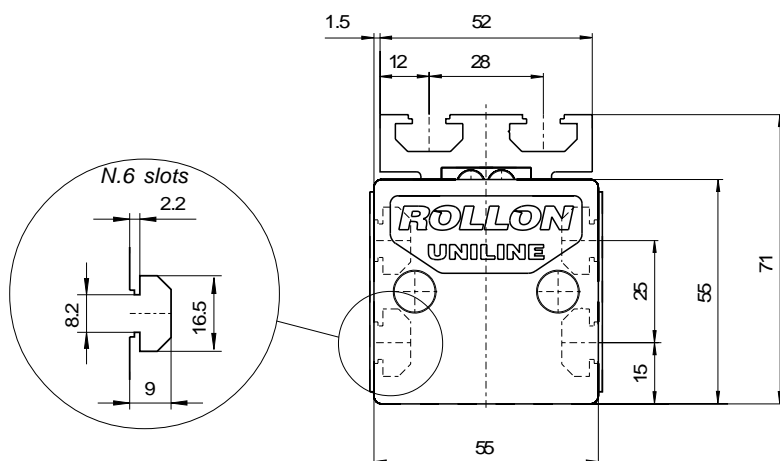

LOAD CAPACITIES

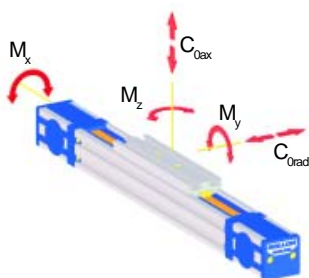

C_{0rad} [N]	C_{0ax} [N]	M_x [Nm]	M_y [Nm]	M_z [Nm]
2175	750	11.5	21.7	54.4

Note: radial load C_{0rad} is considered to be applied along the axis of the internal rail (see page B6).

OTHER FEATURES

Moment of inertia I_y [cm ⁴]	34.6
Moment of inertia I_z [cm ⁴]	41.7
Max speed [m/s]	5
Weight of unit with stroke zero [g]	2897
Weight of unit per meter [g]	4505
Mass of slider [g]	475
Stroke for shaft revolution [mm]	130
Type of guiding rail	TLV28

Type of slider	CSW28 spec. 4 rollers
Pitch diameter of pulley [m]	0.04138
Moment of inertia of mass of each pulley [gmm ²]	45633
Mass of belt [g/m]	74
Max. Belt Tractive Force F_{max} [N]	1330
Standard belt tension [N]	220
Standard starting loadless torque [Nm]	0.22
Belt length [m]	2 x stroke (in m) + 0.630

C55

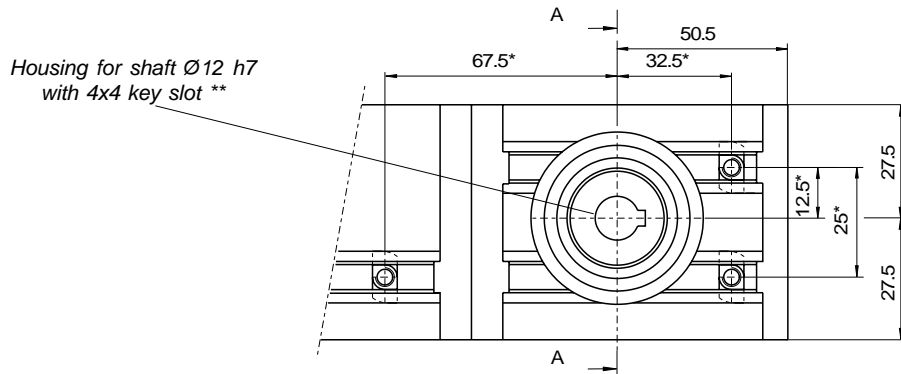
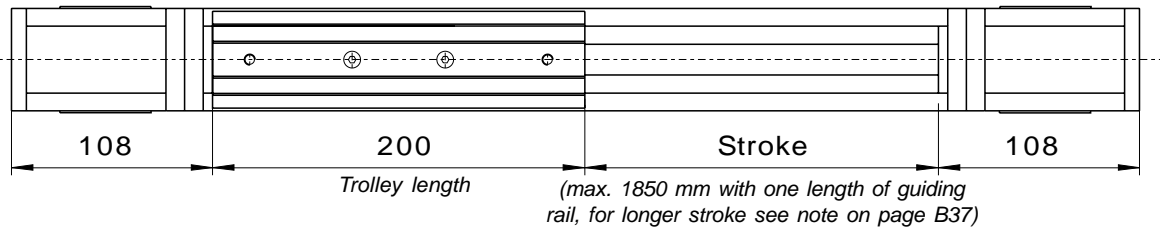

* Position of the T-nuts of our interface plates (see pages B33 and B34).

** In the inch versions (order code suffix "P"), the shaft housing is $\varnothing 1/2"$ with $1/8" \times 1/8"$ keyslot.

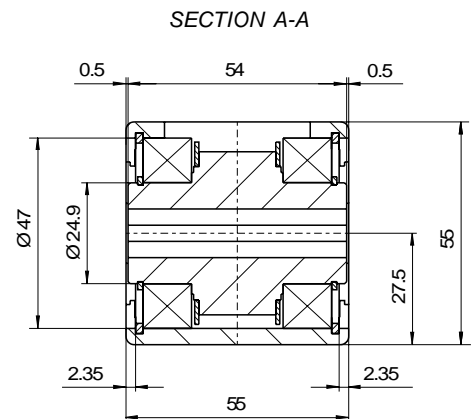
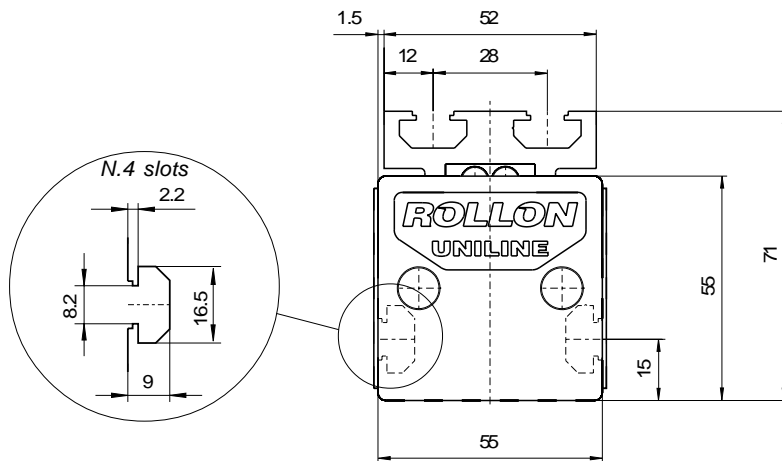

LOAD CAPACITIES

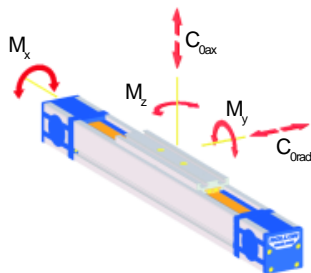

C_{0rad} [N]	C_{0ax} [N]	M_x [Nm]	M_y [Nm]	M_z [Nm]
300	1640	18.5	65.6	11.7

Note: radial load C_{0rad} is considered to be applied along the axis of the internal rail (see page B6).

OTHER FEATURES

Moment of inertia I_y [cm ⁴]	34.4	Type of slider	2 CSW18 spec. 4 rollers
Moment of inertia I_z [cm ⁴]	45.5	Pitch diameter of pulley [m]	0.04138
Max speed [m/s]	3	Moment of inertia of mass of each pulley [gmm ²]	45633
Weight of unit with stroke zero [g]	2971	Mass of belt [g/m]	74
Weight of unit per meter [g]	4605	Max. Belt Tractive Force F_{max} [N]	1330
Mass of slider [g]	549	Standard belt tension [N]	220
Stroke for shaft revolution [mm]	130	Standard starting loadless torque [Nm]	0.3
Type of guiding rail	TLV18/ULV18	Belt length [m]	2 x stroke (in m)+ 0.630

E55

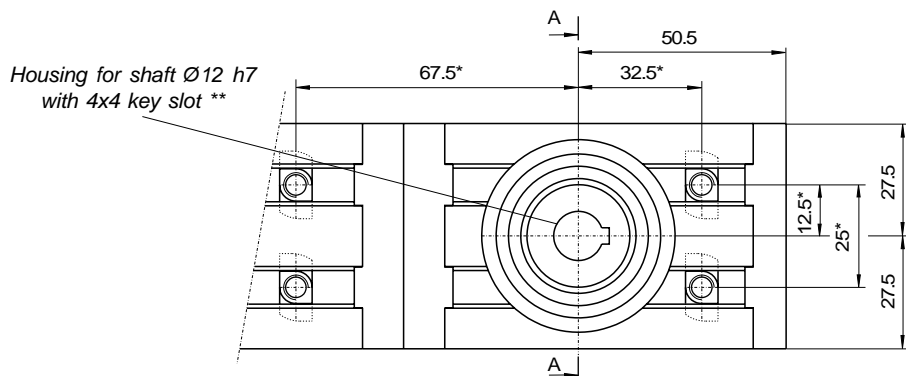
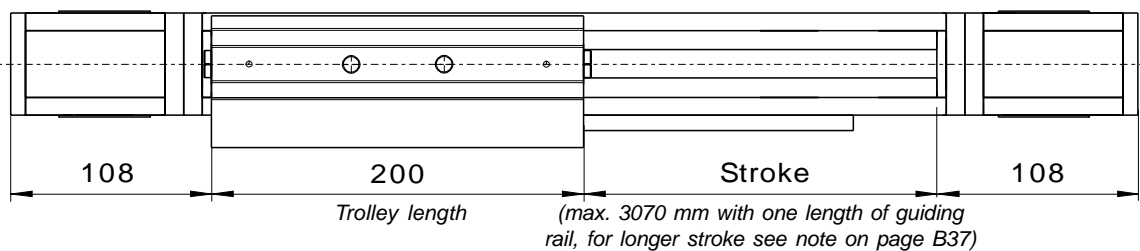

* Position of the T-nuts of our interface plates (see pages B33 and B34).

** In the inch versions (order code suffix "P"), the shaft housing is Ø1/2" with 1/8" x 1/8" keyslot.

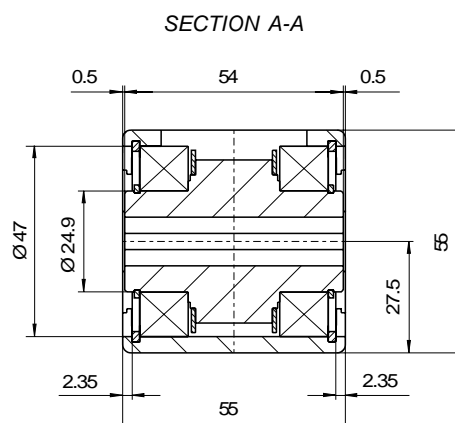
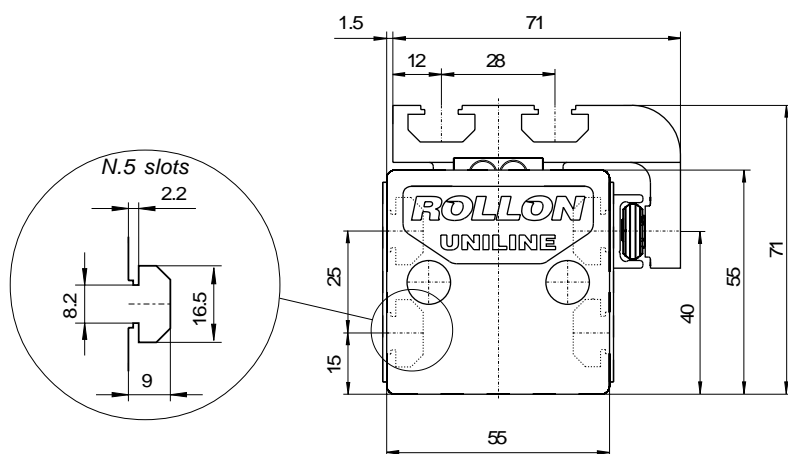

LOAD CAPACITIES

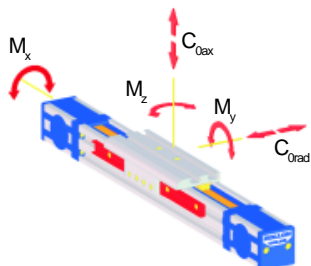

C0rad [N]	C0ax [N]	Mx [Nm]	My [Nm]	Mz [Nm]
2175	1500	25.5	43.4	54.4

Note: radial load C_{0rad} is considered to be applied along the axis of the internal rail (see page B6).

OTHER FEATURES

Moment of inertia I_y [cm ⁴]	34.6	Type of slider	CSW28 spec. 4 rollers / 4 CPA18
Moment of inertia I_z [cm ⁴]	41.7	Pitch diameter of pulley [m]	0.04138
Max speed [m/s]	3	Moment of inertia of mass of each pulley [gmm ²]	45633
Weight of unit with stroke zero [g]	3167	Mass of belt [g/m]	74
Weight of unit per meter [g]	5055	Max. Belt Tractive Force F_{max} [N]	1330
Mass of slider [g]	635	Standard belt tension [N]	220
Stroke for shaft revolution [mm]	130	Standard starting loadless torque [Nm]	0.3
Type of guiding rail	TLV28/ULV18	Belt length [m]	2 x stroke (in m)+ 0.630

A75

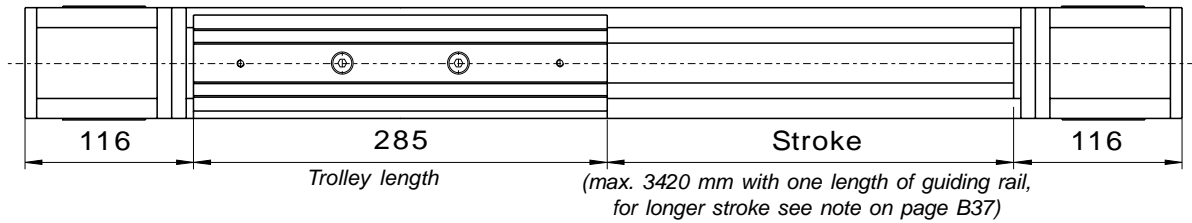

* Position of the T-nuts of our interfaces plates (see pages B33 and B34).

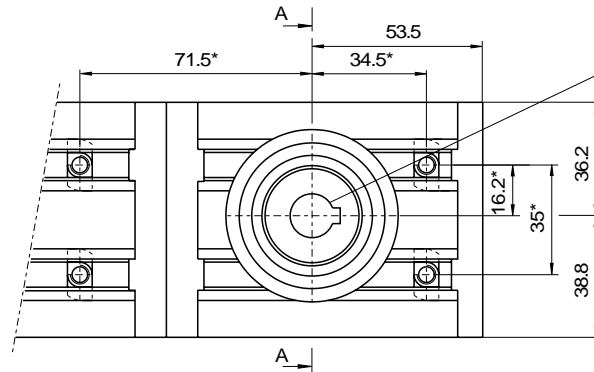

Housing for shaft $\varnothing 14$ h7 with 5x5 key slot **

** In the inch versions (order code suffix "P"), the shaft housing is $\varnothing 5/8$ " with 3/16" x 3/16" key slot.

SPECIAL VERSIONS (upon request):

- $\varnothing 16$ h7 with 5x5 keyway
- $\varnothing 19$ h7 with 6x6 keyway
- $\varnothing 18$ for compression coupling
- $\varnothing 24$ for compression coupling

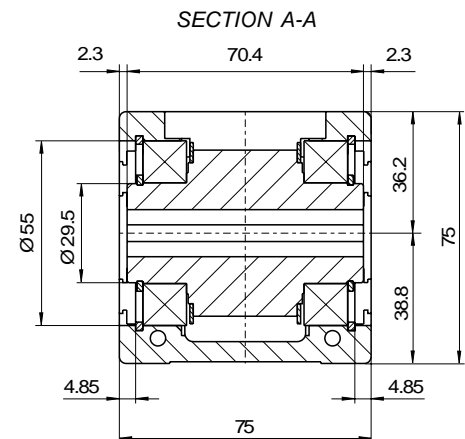
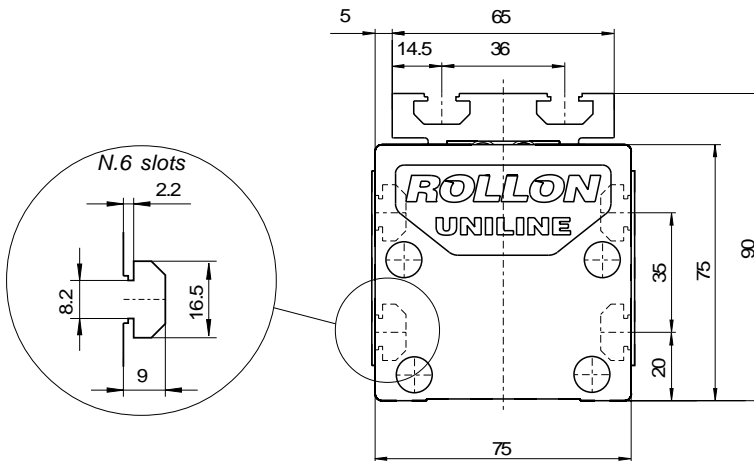

LOAD CAPACITIES

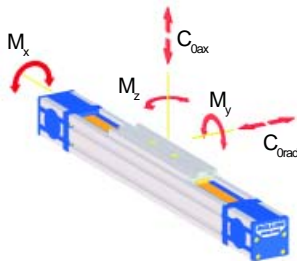

C _{0rad} [N]	C _{0ax} [N]	M _x [Nm]	M _y [Nm]	M _z [Nm]
5500	1855	43.6	81.5	209

Note: radial load C_{0rad} is considered to be applied along the axis of the internal rail (see page B6).

OTHER FEATURES

Moment of inertia I_y [cm ⁴]	127	Type of slider	CSW43 spec. 4 rollers
Moment of inertia I_z [cm ⁴]	172	Pitch diameter of pulley [m]	0.05093
Max speed [m/s]	7	Moment of inertia of mass of each pulley [gmm ²]	139969
Weight of unit with stroke zero [g]	6729	Mass of belt [g/m]	185
Weight of unit per meter [g]	9751	Max. Belt Tractive Force F_{max} [N]	4480
Mass of slider [g]	1242	Standard belt tension [N]	800
Stroke for shaft revolution [mm]	160	Standard starting loadless torque [Nm]	1.15
Type of guiding rail	TLV43	Belt length [m]	2 x stroke (in m)+ 0.792

C75

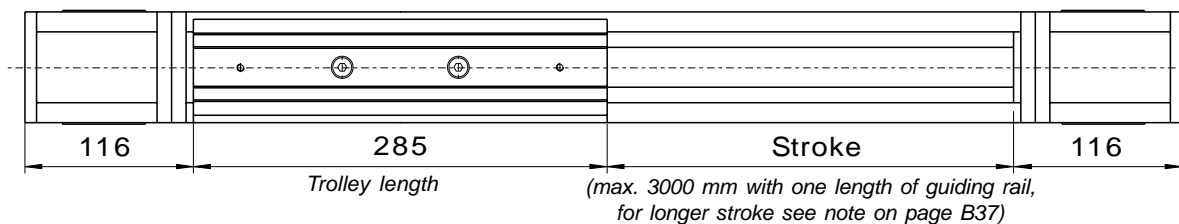

* Position of the T-nuts of our interfaces plates (see pages B33 and B34).

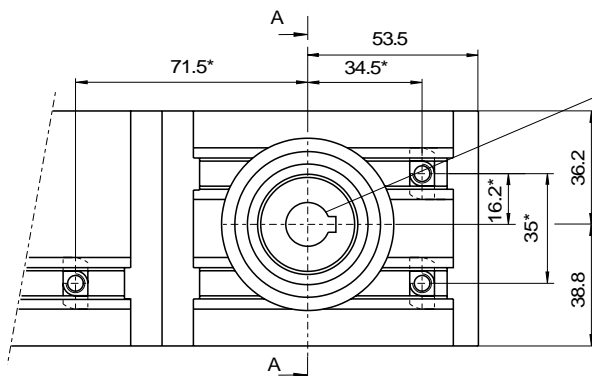

Housing for shaft $\varnothing 14$ h7 with 5x5 key slot **

** In the inch versions (order code suffix "P"), the shaft housing is $\varnothing 5/8$ " with 3/16" x 3/16" key slot.

SPECIAL VERSIONS (upon request):

- $\varnothing 16$ h7 with 5x5 keyway
- $\varnothing 19$ h7 with 6x6 keyway
- $\varnothing 18$ for compression coupling
- $\varnothing 24$ for compression coupling

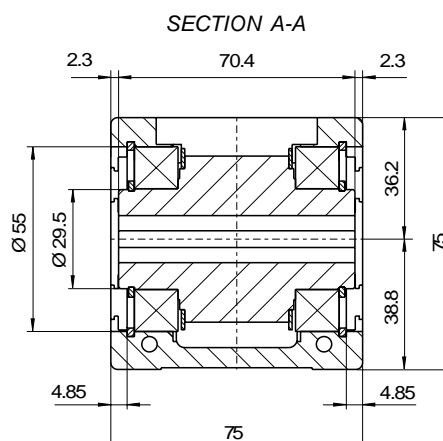
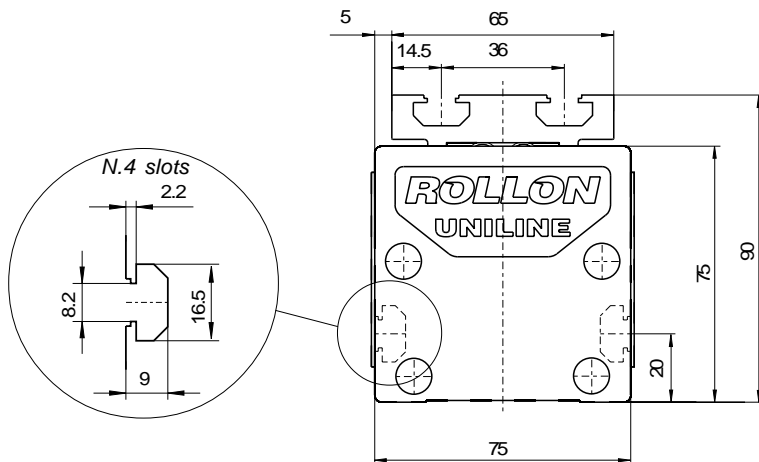

LOAD CAPACITIES

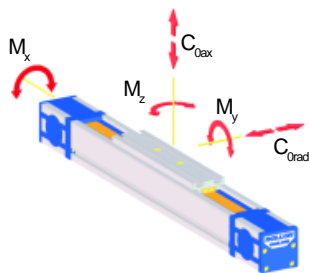

C_{0rad} [N]	C_{0ax} [N]	M_x [Nm]	M_y [Nm]	M_z [Nm]
750	4350	85.2	217	36.1

Note: radial load C_{0rad} is considered to be applied along the axis of the internal rail (see page B6).

OTHER FEATURES

Moment of inertia I_y [cm ⁴]	108	Type of slider	2 CSW28 spec. 4 rollers
Moment of inertia I_z [cm ⁴]	155	Pitch diameter of pulley [m]	0.05093
Max speed [m/s]	5	Moment of inertia of mass of each pulley [gmm ²]	139969
Weight of unit with stroke zero [g]	6853	Mass of belt [g/m]	185
Weight of unit per meter [g]	9151	Max. Belt Tractive Force F_{max} [N]	4480
Mass of slider [g]	1666	Standard belt tension [N]	800
Stroke for shaft revolution [mm]	160	Standard starting loadless torque [Nm]	1.3
Type of guiding rail	TLV28/ULV28	Belt length [m]	2 x stroke (in m)+ 0.792

E75

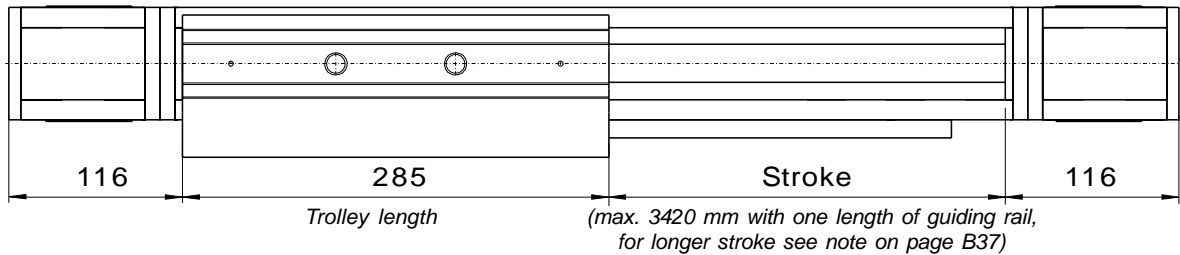

* Position of the T-nuts of our interfaces plates (see pages B33 and B34).

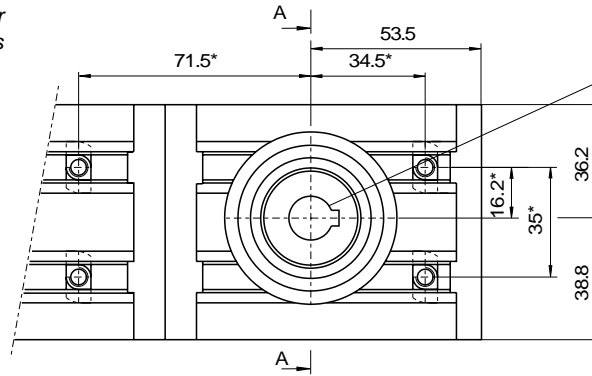

Housing for shaft $\varnothing 14$ h7 with 5x5 key slot **

** In the inch versions (order code suffix "P"), the shaft housing is $\varnothing 5/8$ " with 3/16" x 3/16" key slot.

SPECIAL VERSIONS (upon request):

- $\varnothing 16$ h7 with 5x5 keyway
- $\varnothing 19$ h7 with 6x6 keyway
- $\varnothing 18$ for compression coupling
- $\varnothing 24$ for compression coupling

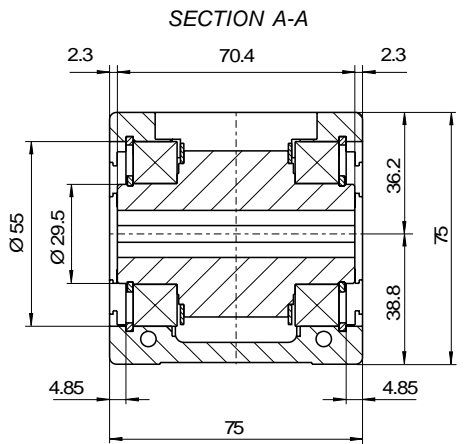
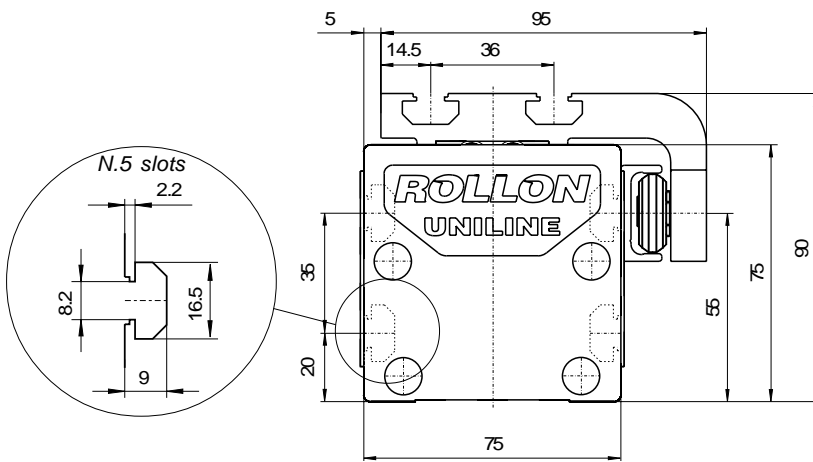

LOAD CAPACITIES

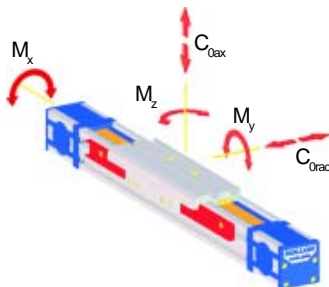

C _{0rad} [N]	C _{0ax} [N]	M _x [Nm]	M _y [Nm]	M _z [Nm]
5500	3710	85.5	163	209

Note: radial load C_{0rad} is considered to be applied along the axis of the internal rail (see page B6).

OTHER FEATURES

Moment of inertia I_y [cm ⁴]	127
Moment of inertia I_z [cm ⁴]	172
Max speed [m/s]	5
Weight of unit with stroke zero [g]	7544
Weight of unit per meter [g]	10751
Mass of slider [g]	1772
Stroke for shaft revolution [mm]	160
Type of guiding rail	TLV43/ULV28

Type of slider	CSW43 spec. 4 rollers / 4 CPA28
Pitch diameter of pulley [m]	0.05093
Moment of inertia of mass of each pulley [gmm ²]	139969
Mass of belt [g/m]	185
Max. Belt Tractive Force F_{max} [N]	4480
Standard belt tension [N]	800
Standard starting loadless torque [Nm]	1.3
Belt length [m]	2 x stroke (in m)+ 0.792

ED75

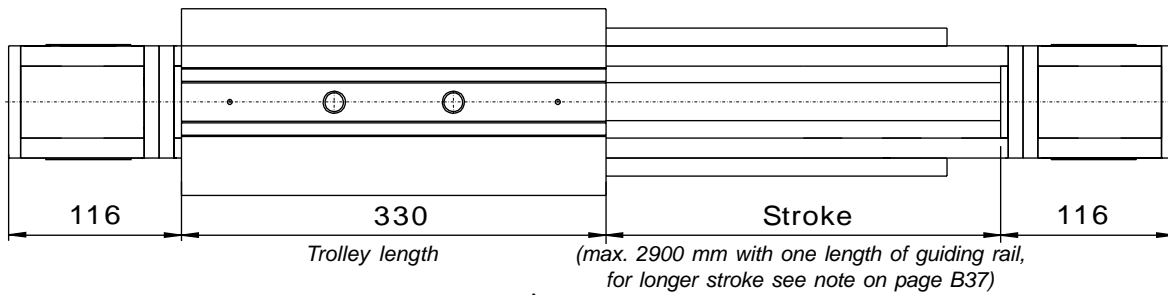

* Position of the T-nuts of our interfaces plates (see pages B33 and B34).

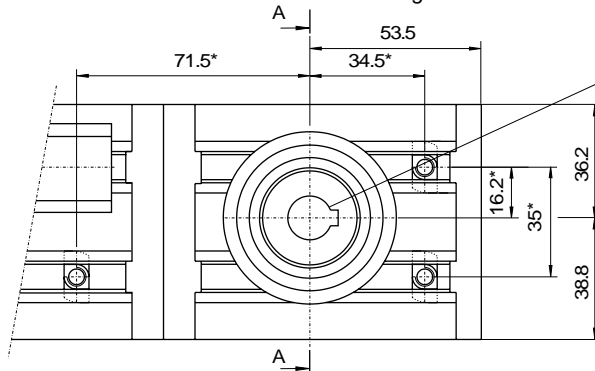

Housing for shaft $\varnothing 14$ h7 with 5x5 key slot **

** In the inch versions (order code suffix "P"), the shaft housing is $\varnothing 5/8$ " with 3/16" x 3/16" key slot.

SPECIAL VERSIONS (upon request):

- $\varnothing 16$ h7 with 5x5 keyway
- $\varnothing 19$ h7 with 6x6 keyway
- $\varnothing 18$ for compression coupling
- $\varnothing 24$ for compression coupling

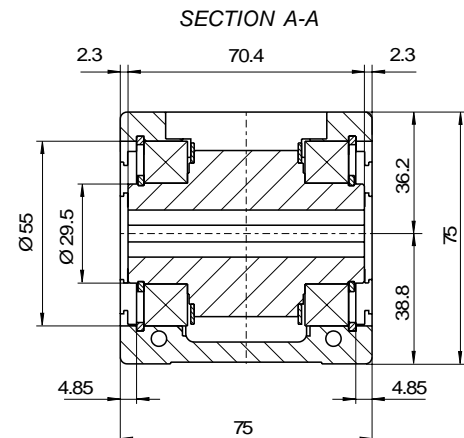
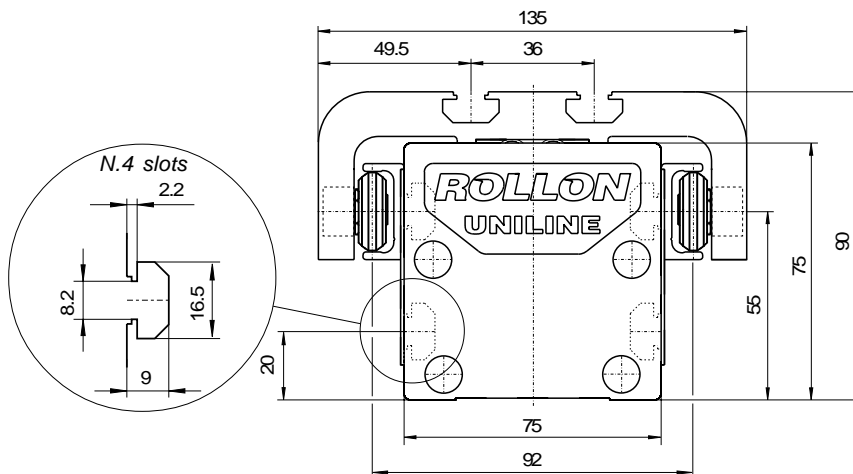

LOAD CAPACITIES

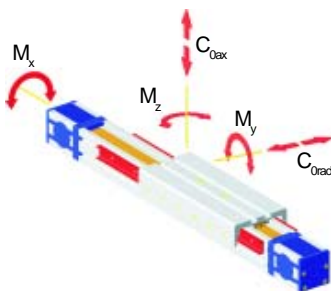

C_{0rad} [N]	C_{0ax} [N]	M_x [Nm]	M_y [Nm]	M_z [Nm]
5500	8700	400.2	696	240

Note: radial load C_{0rad} is considered to be applied along the axis of the internal rail (see page B6).

OTHER FEATURES

Moment of inertia I_y [cm ⁴]	127
Moment of inertia I_z [cm ⁴]	172
Max speed [m/s]	5
Weight of unit with stroke zero [g]	9850
Weight of unit per meter [g]	14400
Mass of slider [g]	3770
Stroke for shaft revolution [mm]	160
Type of guiding rail	ULV43/ULV28

Type of slider	CSW43 spec. / CSW28 spec.
Pitch diameter of pulley [m]	0.05093
Moment of inertia of mass of each pulley [gmm ²]	139969
Mass of belt [g/m]	185
Max. Belt Tractive Force F_{max} [N]	4480
Standard belt tension [N]	1000
Standard starting loadless torque [Nm]	1.5
Belt length [m]	2 x stroke (in m)+ 0.920

VERSION "L" (Long trolley)

"L"-versions have a longer trolley mounted on two internal sliders instead of one. The load and moment capacities obtainable, particularly the M_y and M_z , are much higher than those of the base versions. For the M_y and M_z moment capacities which refer to a specific trolley length please refer to page B24.

A40L

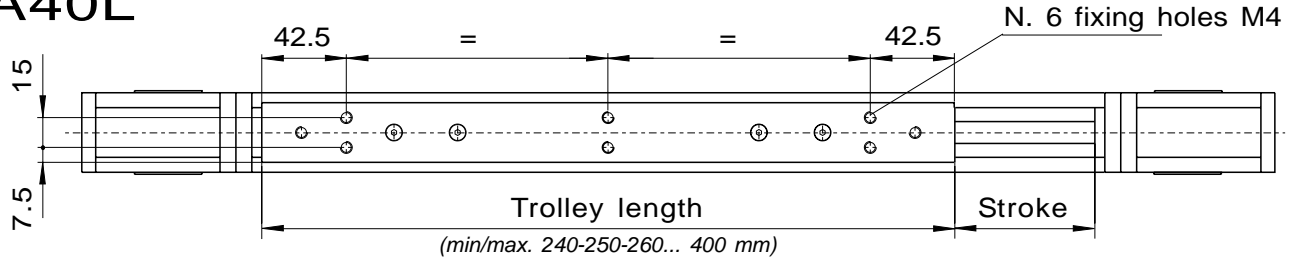

Type	C_{0rad} [N]	C_{0ax} [N]	M_x [Nm]	M_y [Nm]	M_z [Nm]	Max stroke with max trolley length [mm] *
A40L	1640	600	5.6	from 22 to 70	from 61 to 192	1660

* The values refer to the maximum length of a non joined rail. For longer strokes see note on page B37.

A55L, C55L, E55L

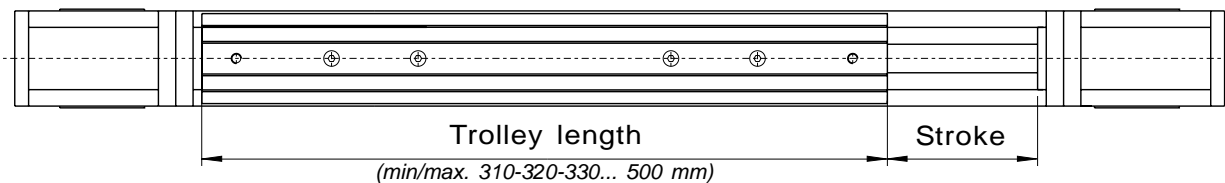

Type	C_{0rad} [N]	C_{0ax} [N]	M_x [Nm]	M_y [Nm]	M_z [Nm]	Max stroke with max trolley length [mm] **
A55L	4350	1500	23	from 82 to 225	from 240 to 652	2770
C55L	600	3280	37	from 213 to 525	from 39 to 96	1550
E55L*	4350	3000	51	from 165 to 450	from 239 to 652	2770

* Only length 310 mm is considered standard, longer trolleys are considered special products.

** The values refer to the maximum length of a non joined rail. For longer strokes see note on page B37.

A75L, C75L, E75L, ED75L*

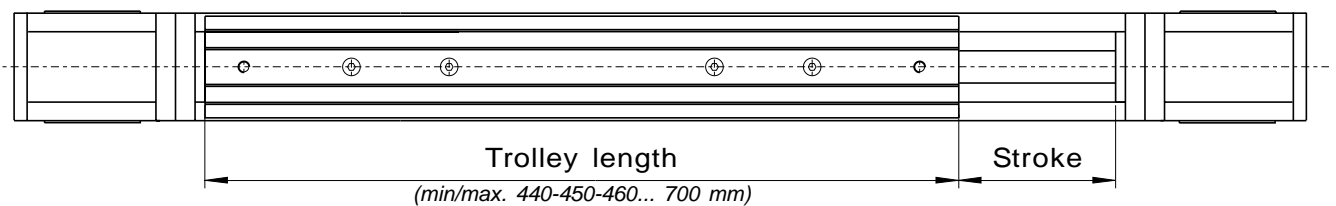

Type	C_{0rad} [N]	C_{0ax} [N]	M_x [Nm]	M_y [Nm]	M_z [Nm]	Max stroke with max trolley length [mm] **
A75L	11000	3710	87.2	from 287 to 770	from 852 to 2282	3000
C75L	1500	8700	170.4	from 674 to 1805	from 116 to 311	2610
E75L*	11000	7420	171	from 575 to 1540	from 852 to 2282	3000
ED75L*	11000	8700	400.2	from 1174 to 2305	from 852 to 2282	2500

* Only length 440 mm is considered standard, longer trolleys are considered special products.

** The values refer to the maximum length of a non joined rail. For longer strokes see note on page B37.

Order code:

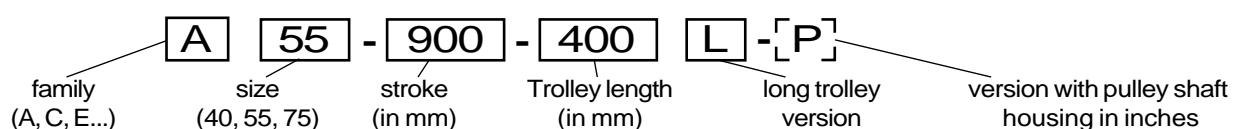

VERSION "D" (Double trolley)

"D"-versions have an extra trolley connected to the first by a toothed belt. The load and moment capacities obtainable, particularly the M_y and M_z , are much higher than those of the base versions. For the M_y and M_z moment capacities which refer to a specific distance between trolley centers please refer to page B23.

A40D

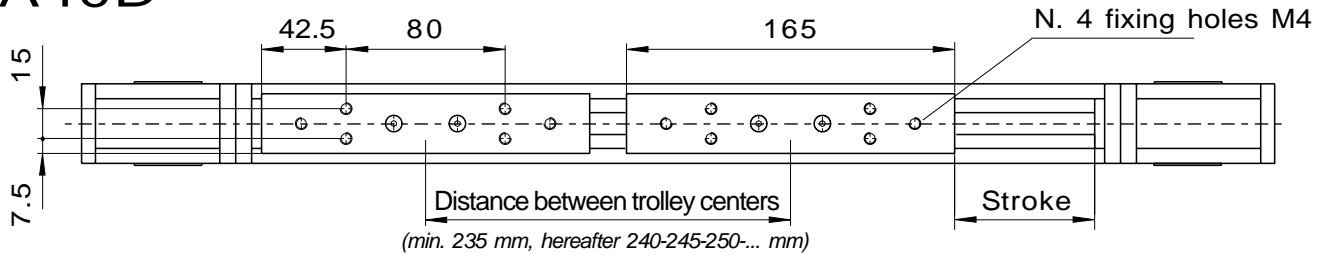

Type	C_{0rad} [N]	C_{0ax} [N]	M_x [Nm]	M_y [Nm]	M_z [Nm]	Max distance with stroke 0 [mm] *	Max stroke with min. distance [mm] *
A40D	1640	600	5.6	from 70 to 570	from 193 to 1558	1900	1660

* The values refer to the maximum length of a non joined rail. For longer strokes see note on page B36.

A55D, C55D, E55D

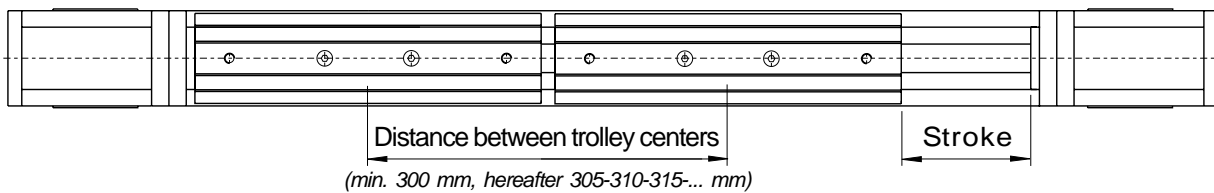

Type	C_{0rad} [N]	C_{0ax} [N]	M_x [Nm]	M_y [Nm]	M_z [Nm]	Max distance with stroke 0 [mm] *	Max stroke with min. distance [mm] *
A55D	4350	1500	23	from 225 to 2302	from 652 to 6677	3070	2770
C55D	600	3280	37	from 492 to 3034	from 90 to 555	1850	1570
E55D	4350	3000	51	from 450 to 4605	from 652 to 6677	3070	2770

* The values refer to the maximum length of a non joined rail. For longer strokes see note on page B36.

A75D, C75D, E75D, ED75D

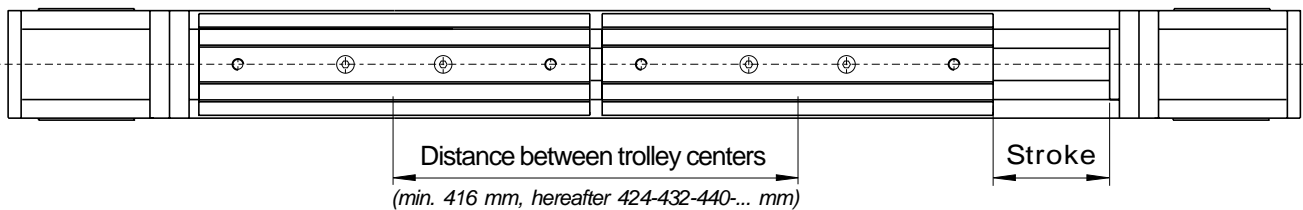

Type	C_{0rad} [N]	C_{0ax} [N]	M_x [Nm]	M_y [Nm]	M_z [Nm]	Max distance with stroke 0 [mm] *	Max stroke with min. distance [mm] *
A75D	11000	3710	87.2	from 771 to 6336	from 2288 to 18788	3416	3000
C75D	1500	8700	170.4	from 1809 to 13154	from 312 to 2268	3024	2610
E75D	11000	7420	171	from 1543 to 12673	from 2288 to 18788	3416	3000
ED75D	11000	17400	800.4	from 3619 to 24917	from 2288 to 15752	2864	2450

* The values refer to the maximum length of a non joined rail. For longer strokes see note on page B36.

Order code:

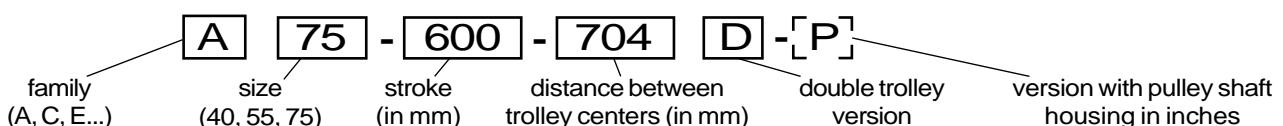

VERSION "H"

The **H** units are "slave units" with a **COMPACT RAIL** U-rail inside. The U-rail and slider allow the units to function and absorb parallelism errors in the mounting structure. The **H** units consist of the aluminum profile, a U-rail and slider, and the trolley. There are no pulleys and there is no belt. These units must always be mounted close together with another **UNILINE** actuator (not another **H** unit).

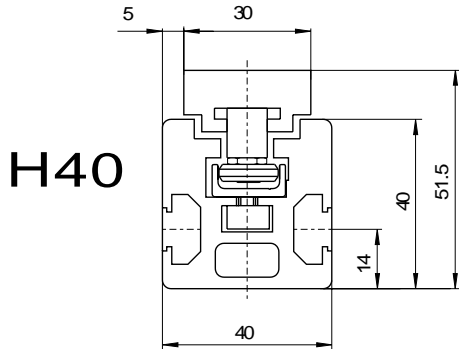

H40

Tipo	C _{0rad} [N]	C _{0ax} [N]	M _x [Nm]	M _y [Nm]	M _z [Nm]
H40	820	0	0	0	13.1
H40L	1640	0	0	0	da 61 a 192
H40D	1640	0	0	0	da 192 a 1558

Note: the only loads these units can be subjected to are radial load and M_z moment.

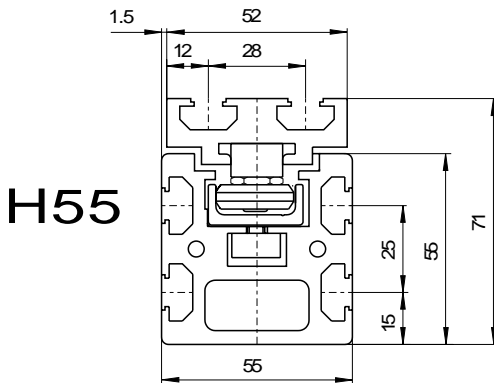

H55

Tipo	C _{0rad} [N]	C _{0ax} [N]	M _x [Nm]	M _y [Nm]	M _z [Nm]
H55	2175	0	0	0	54.4
H55L	4350	0	0	0	da 239 a 652
H55D	4350	0	0	0	da 652 a 6677

Note: the only loads these units can be subjected to are radial load and M_z moment.

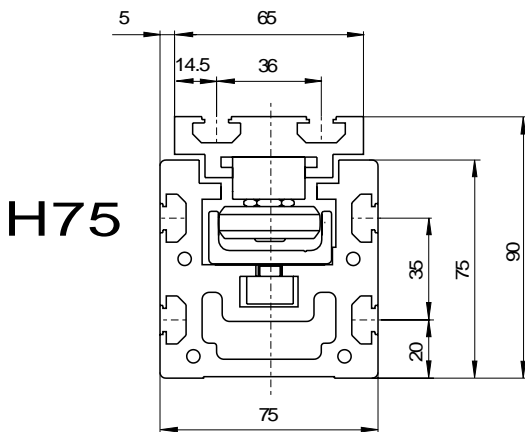

H75

Tipo	C _{0rad} [N]	C _{0ax} [N]	M _x [Nm]	M _y [Nm]	M _z [Nm]
H75	5500	0	0	0	209
H75L	11000	0	0	0	da 852 a 2282
H75D	11000	0	0	0	da 2288 a 18788

Note: the only loads these units can be subjected to are radial load and M_z moment.

Order codes:

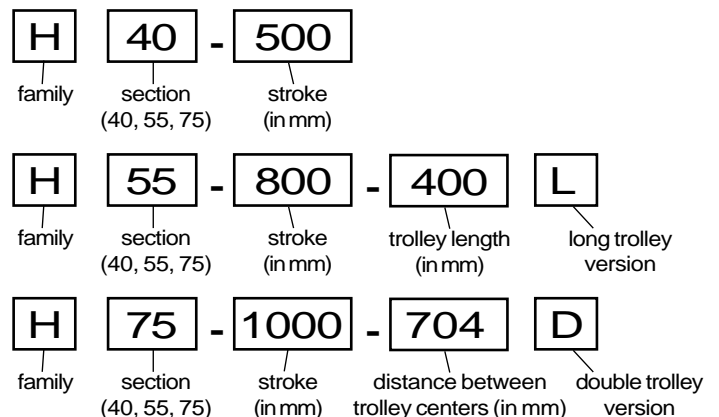

VERIFICATION UNDER STATIC LOAD

CALCULATION

The values of static load rating, given on page B10, represent the maximum allowable loads above which a permanent deformation of the raceways could occur and consequently the running quality could be compromised.

The verification is made:

- by calculating the forces and the moments acting simultaneously on the unit trolley.
- by comparing these values with the corresponding load ratings.

If:

P_r , P_a are the radial and axial resultants of the external forces (N);

M_1 , M_2 , M_3 are the external moments (Nm);

C_{0rad} , C_{0ax} , M_x , M_y , M_z are the load ratings in the various directions given on page B10;

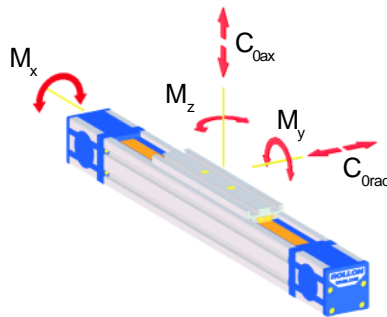

z is the safety factor (see relative table);

the result should be:

$$\frac{P_r}{C_{0rad}} < \frac{1}{z} \quad \frac{P_a}{C_{0ax}} < \frac{1}{z} \quad \frac{M_1}{M_x} < \frac{1}{z} \quad \frac{M_2}{M_y} < \frac{1}{z} \quad \frac{M_3}{M_z} < \frac{1}{z}$$

If two or more of the described loads act together, the result should be:

$$\frac{P_r}{C_{0rad}} + \frac{P_a}{C_{0ax}} + \frac{M_1}{M_x} + \frac{M_2}{M_y} + \frac{M_3}{M_z} \leq \frac{1}{z} \quad [1]$$

The safety factor z should be lower when the dynamic forces to be added to the loads can be determined accurately, and higher when overloads may occur, especially dynamic loads such as shocks and vibrations.

z	
neither shocks nor vibrations; smooth and low frequency reverse; high precision in assembly; no elastic yielding	1 - 1.5
normal assembly condition;	1.5 - 2
shocks and vibration; high elastic yield; high reverse frequency	2 - 3.5

Please contact our Application Engineering department if further information is required.

LIFETIME

LIFE CALCULATION

The dynamic load rating **C** is a conventional load rating used in life calculations. The life to which this load rating is related is 100 km. The values of **C** are indicated for each family of linear unit in the table below.

Life, load rating and equivalent external load are related to each other by the formula:

$$L_{km} = 100 \cdot \left(\frac{C}{P} \cdot \frac{f_c}{f_i} \cdot f_h \right)^3$$

- L_{km} is the theoretical life in km;
- **C** is the dynamic load rating in Newton;

Families	A			C		E		ED	H		
Type	A40	A55	A75	C55	C75	E55	E75	ED75	H40	H55	H75
C [N]	1530	4260	12280	560	1470	4260	12280	9815	1530	4260	12280

Note: for long and double trolley versions the value of dynamic load rating "C" is double.

- **P** is the equivalent external load in Newton;

The equivalent external load **P** is the load whose effect is equivalent to the sum of the effects of forces and moments acting simultaneously on the trolley.

P can be calculated with the following formula:

$$P = P_r + \left(\frac{P_a}{C_{0ax}} + \frac{M_1}{M_x} + \frac{M_2}{M_y} + \frac{M_3}{M_z} \right) \cdot C_{0rad}$$

In the above expression the loads are considered as constant in time. Instantaneous forces do not influence the life and can therefore be disregarded.

- f_c is the contact factor (1 for standard trolley; 0.8 for long and double trolley versions);
- f_i is the service factor. It has a similar meaning to that of the safety factor **z** in the verification under static load. It is equal to:

f i	
neither shocks nor vibrations; smooth and low frequency reverse; clean working environment; low speed (<1m/s)	1 - 1.5
light vibrations; medium speed (between 1 and 2.5 m/s) and medium reverse frequency	1.5 - 2
shocks and vibrations; high speed (>2.5 m/s) and high reverse frequency; very polluted working environment	2 - 3.5

- f_h is the stroke factor;

The stroke factor f_h takes account of the fact that the raceways are stressed more frequently when the slider runs short strokes with equal total run. The graph gives the values of f_h (with strokes longer than 1 m, f_h remains equal to 1):

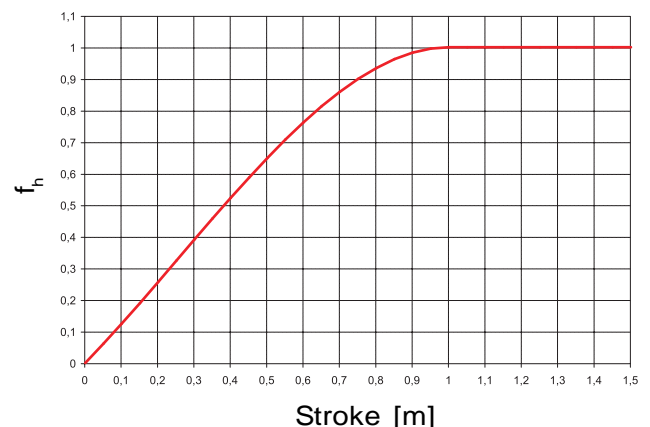

CALCULATION METHODS

M_z and M_y FOR LONG TROLLEY VERSION

On page B19 the moment M_z and M_y load capacities relative to minimum and maximum long trolley are shown. To calculate the moment M_z and M_y load capacities for other trolley lengths use the following formulas:

$$M_{zn} = \left(1 + \frac{L_n - L_{\min}}{K}\right) \cdot M_{z \min}$$

$$M_{yn} = \left(1 + \frac{L_n - L_{\min}}{K}\right) \cdot M_{y \min}$$

Where:

- M_{zn} and M_{yn} are the M_z and M_y moments that refer to the specific length of trolley (Nm);

- L_n is the length of the trolley (mm);

- L_{\min} is the minimum length of the trolley indicated on page B19 (mm);

- k is a constant value:

A40	74
A55 - E55	110
C55	130
A75 - C75 - E75 - ED75	155
ED75 (M_y)	270

- $M_{z \min}$ and $M_{y \min}$ are the minimum M_z and M_y moments indicated on page B19 (Nm);

M_z and M_y FOR DOUBLE TROLLEY VERSION

On page B20 the moment M_z and M_y load capacities relative to minimum and maximum distance between trolley centers are shown. To calculate the moment M_z and M_y load capacities for different distances between trolley centers, use the following formulas:

$$M_{zn} = \frac{I_n}{I_{\min}} \cdot M_{z \min}$$

$$M_{yn} = \frac{I_n}{I_{\min}} \cdot M_{y \min}$$

Where:

- M_{zn} and M_{yn} are the M_z and M_y moments which refer to the specific distance between trolley centers (Nm);

- I_n is the distance between trolley centers (mm);

- I_{\min} is the minimum distance between trolley centers indicated on page B20 (mm);

- $M_{z \min}$ and $M_{y \min}$ are the minimum M_z and M_y moments indicated on page B20 (Nm);

MOTOR TORQUE CALCULATION

The motor torque C_m needed on the driving pulley can be calculated using the following formula:

$$C_m = C_v + \left(F \cdot \frac{D_p}{2}\right)$$

**Max torque for standard
belt tension**

40 series	55 series	75 series	ED75 series
2.16 Nm	4.55 Nm	20.37 Nm	25.46 N

See page B31.

Where:

- C_m is the motor torque (Nm);

- C_v is the standard starting loadless torque indicated for each family from page B11 to page B18 (Nm);

- F is the force applied on the belt (N);

- D_p is the pitch diameter of pulley indicated for each family from page B11 to page B18 (m);

Please contact our Application Engineering department if further information is required.

MOUNTING CONFIGURATIONS AND INSTRUCTIONS

In this chapter the most typical mounting configurations of **UNILINE** units are shown below. For more information about these and other configurations, please consult our application engineering dept.

Depending on the technical characteristics (loads, speed, acceleration, etc.), your application may have different requirements even if it seems to fit a particular example shown.

For more information, please consult our application engineering dept.

All plates mentioned in this chapter come with all the holes necessary for connecting any two units. They also come complete with T-nuts and screws.

Please note that in case the plates are used with “**C**” family units, some fixing holes on the supporting profile are not used because the profiles have only one slot. This does not effect the performance.

When connecting two or more units please make sure that the connection is made to the profile body and not the heads alone.

SINGLE UNIT

As the tables on page B9 show, the correct choice of **UNILINE** units depends heavily on the type of loads the unit is subject to. The most important factor in the choice of a single unit is often the rigidity of the system. Which family will offer the most **rigidity** is strictly related to the type and location of load the system is subject to.

In an application with an Mx moment load as seen in the example below, page B9 will show that the “**E**” - “**ED**” families of actuators would be the best choices.

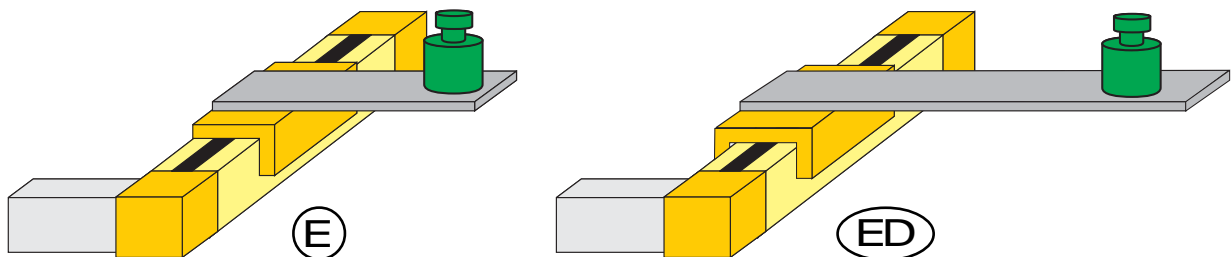

PARALLEL UNITS

a) With synchronized drive shaft:

Generally, the best solution would be a pair of “**A**” family actuators. Their load capacities and rigidity would give a high level of reliability to the system. Please specify “**synchronized**” when ordering (see page B37).

b) Without synchronized drive shaft:

This solution is not advisable unless the distance between the units is minimal (if the distance is too great, a single drive could possibly cause “**misalignment**” of the nondriven unit’s slider in phases of acceleration/deceleration). If positioned at close distance, generally the best solution would be a pair of “**A**” family actuators or a combination of “**A**” family and “**H**” family actuators (please contact our Application Engineering department for more information).

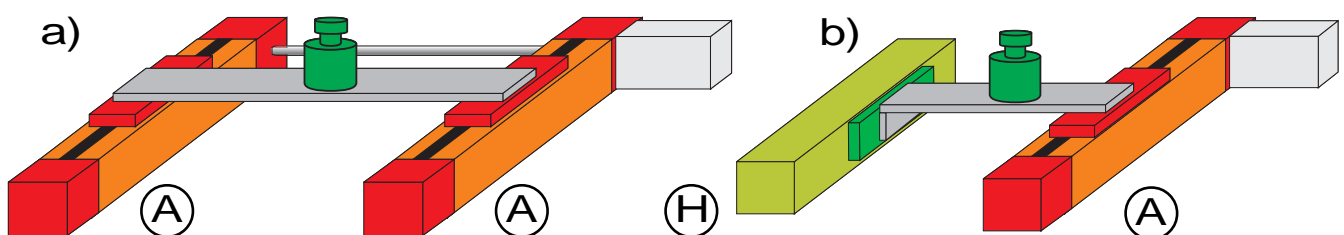

2 AXIS GANTRY (2X-Y)

This example shows a gantry where the connection of the two axes is obtained by attaching the two parallel unit trolleys with the central unit heads by means of a pair of T-plates (Rollon part # APC-1). See detailed drawing on page B35.

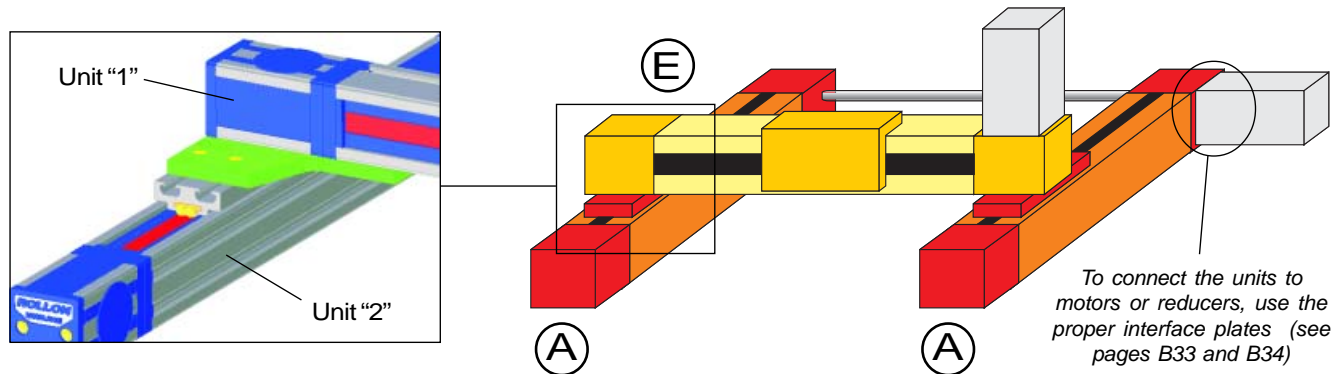

The mounting procedure is as follows:

1. Fix the plates to unit 1, the Y-axis, by inserting the screws and T-nuts in the proper holes and slots (see Fig.1 as reference). Assure the T-nuts are rotated 90° in their slots when tightened. Recommended tightening torque is 10 Nm (max.).
2. Attach plates to the unit 2 trolleys making sure to center unit 1 on the trolleys (see Fig. 2). Assure the T-nuts are rotated 90° in their slots when tightened. Recommended tightening torque is 10 Nm (max.).

Fig.1

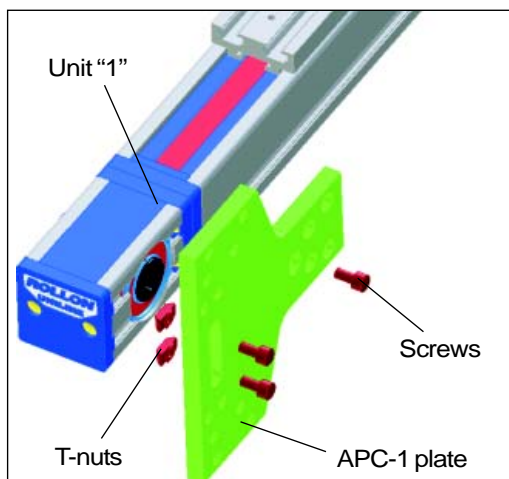
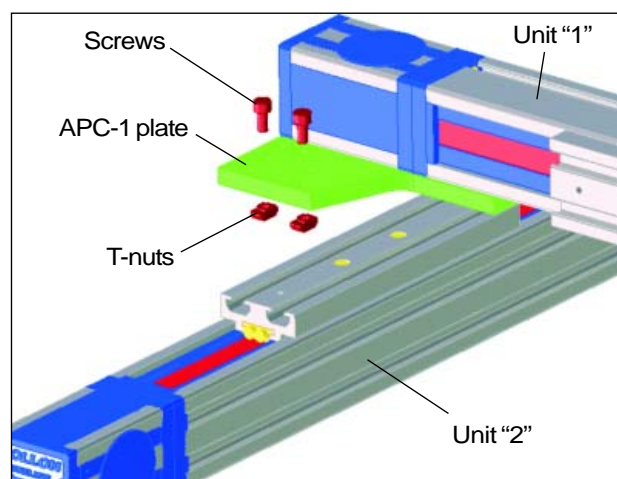
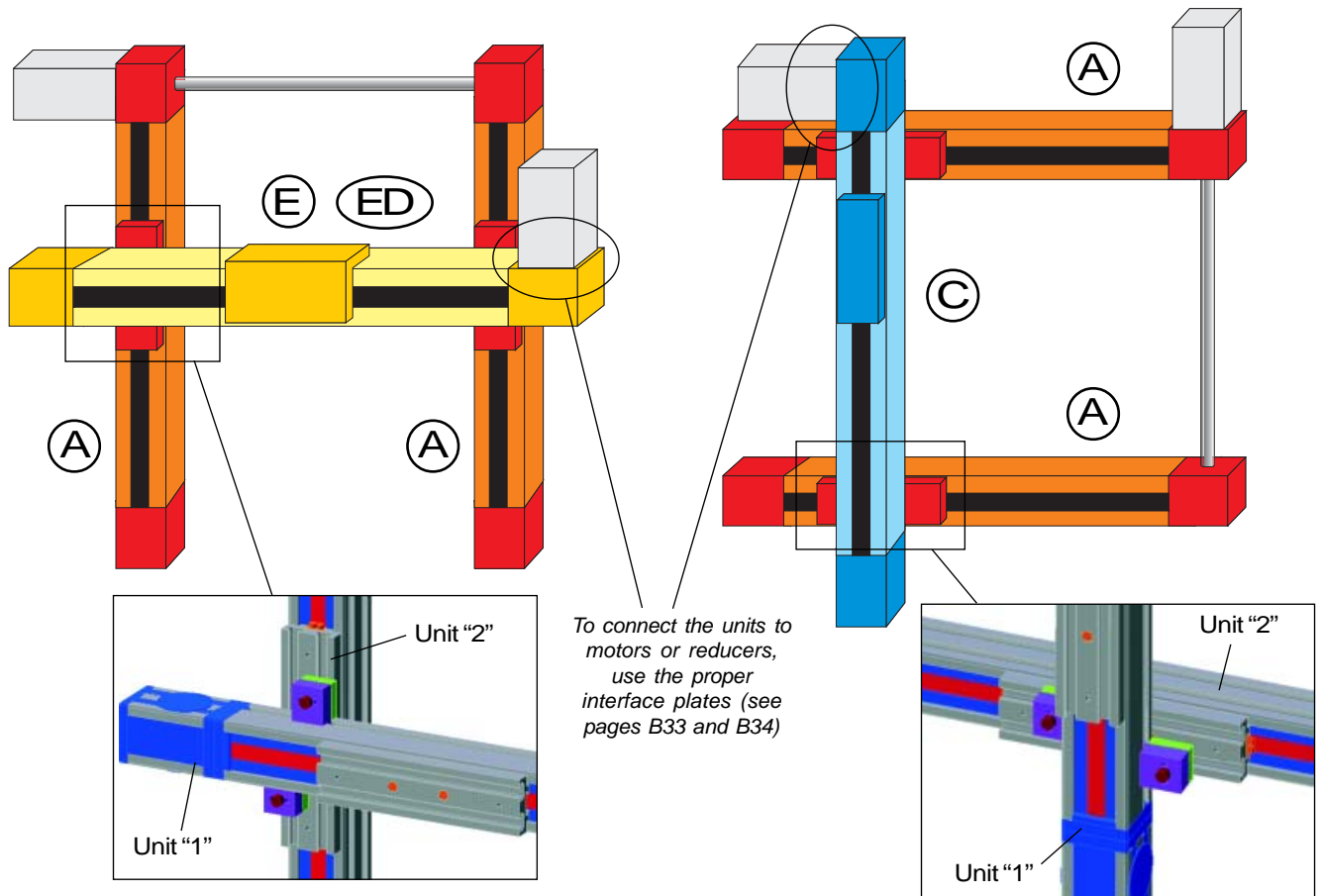

Fig.2



2 AXIS GANTRY (Y-2Z and 2Y-Z)

In the examples below two typical mounting configurations of 2-axis manipulators are shown. The difference between them is the direction of movement of the axes; in the first case the "single" axis is horizontal, in the second it is vertical. For this reason and for the fact the acting loads could also be different, the units used are of different types (for more information, please consult our Application Engineering dept.). In both cases APF-2 mounting blocks are used. These blocks connect the supporting profile of the single unit to the center of the trolleys of the parallel units. The mounting instructions of the blocks are on page B36.



The mounting procedure is as follows:

1. Insert the projecting part of the mounting block into the lower slot of unit 1 (see page B36).
2. Position the block so that the hole is 90° to the mounting surface (centered on unit 2 trolley). Insert, if necessary, a shim between the block and the trolley (shim not supplied).
3. Insert the fixing screws in the block and tighten. Recommended tightening torque is 10 Nm (max.)
4. Repeat steps 1-3 for the necessary number of blocks.

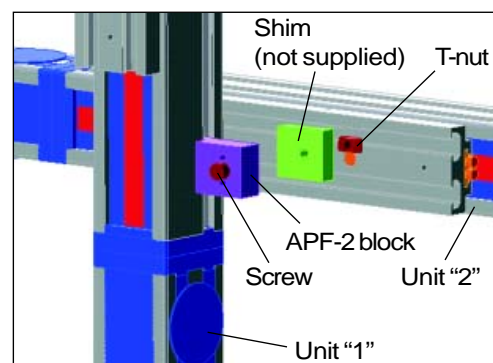
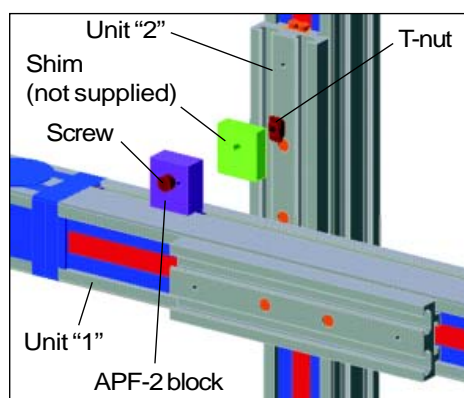

X-Y GANTRY

Another typical application of linear actuators is the “XY-gantry”. In this first example, a unit is fixed to the other by connecting its trolley and the other unit’s profile using the APF-2 mounting blocks. Consequently, the moving part of the system must be connected to the “C” family unit trolley. The mounting instructions of the APF-2 blocks are exactly as in the previous examples.

To connect the units to motors or reducers, use the proper interface plates (see pages B33 and B34)

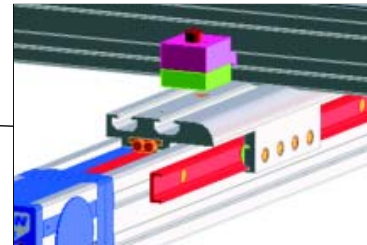
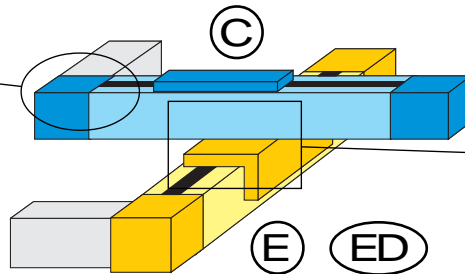

X-Z GANTRY

In this second example, one unit is fixed to the other by connecting the two trolleys using an X-plate (Rollon part # APC-3; for a detailed drawing of the plate see page B36). Consequently, the moving part of the system will be connected to the supporting profile of the vertical unit.

To connect the units to motors or reducers, use the proper interface plates (see pages B33 and B34)

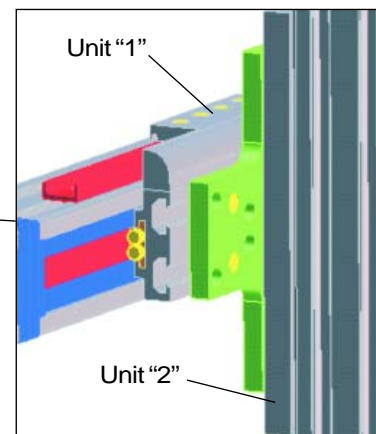
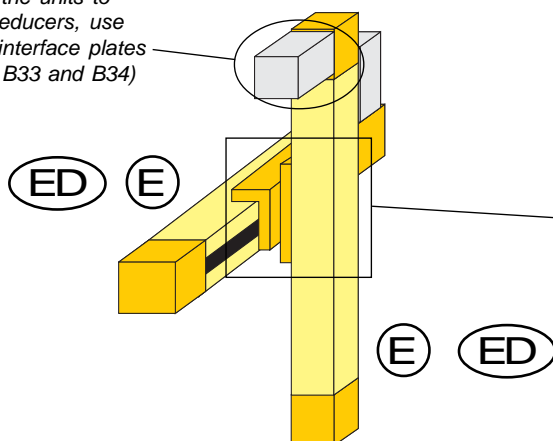

The mounting procedure is as follows:

1. Fix the plate to unit 1 trolley by inserting the screws and T-nuts in the proper holes and slots (see Fig.1 as reference). Assure the T-nuts are rotated 90° in their slots when tightened. Recommended tightening torque is 10 Nm (max.)
2. Attach plate to the unit 2 trolley making sure to center unit 1 on the trolley (see Fig. 2). Assure the T-nuts are rotated 90° in their slots when tightened. Recommended tightening torque is 10 Nm (max.)

Fig.1

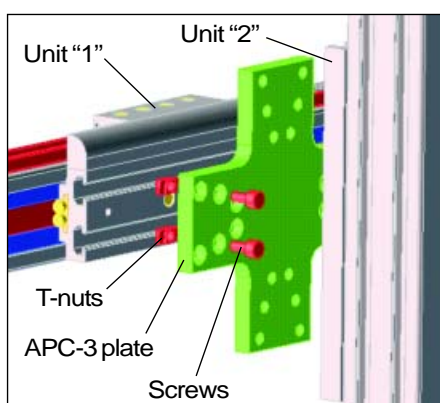
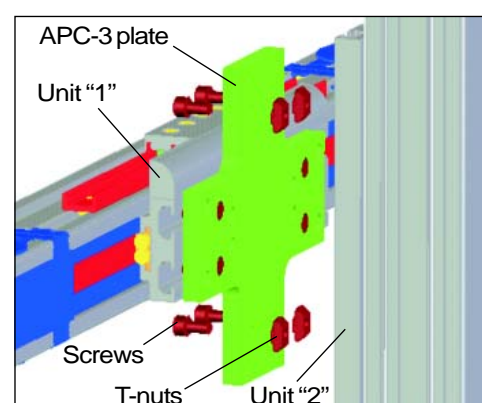
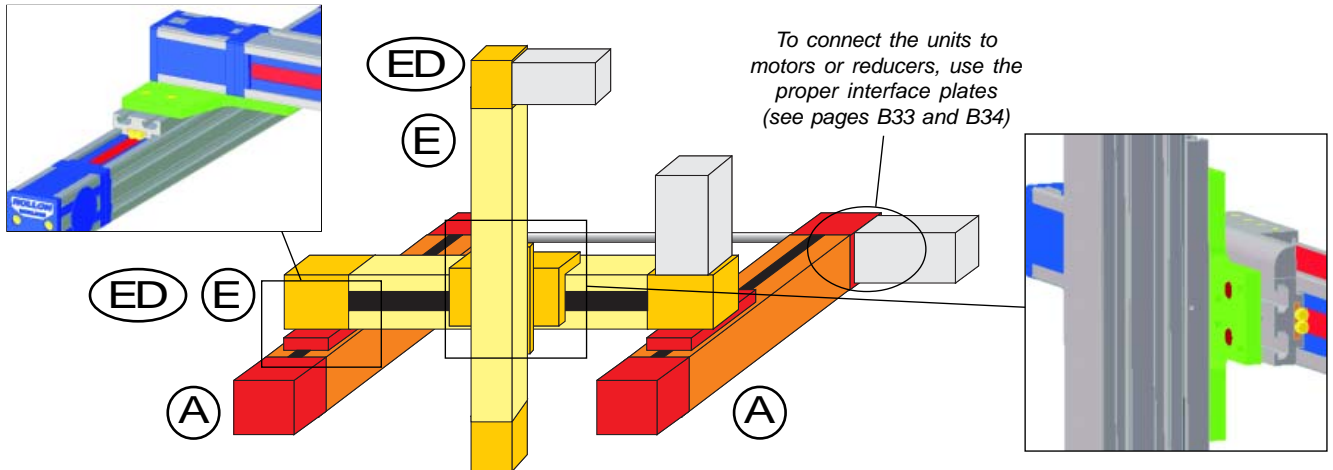

Fig.2



3 AXIS GANTRY (2X-Y-Z)

This example is a 3-axis gantry obtained by connecting four linear actuators. The vertical axis is attached to the center unit by connecting the trolleys with an X-plate (Rollon part# APC-3; for a detailed drawing of the plate see page B36). The connection between the parallel units and the center one is obtained using a T-plate (Rollon part# APC-1; for detailed drawings of the plate see page B35). The plate mounting instructions are the same as the previous examples.



3 AXIS GANTRY (2X-2Y-Z)

In this case, the vertical axis Z is mounted between two parallel units 2Y to improve the stiffness of the complete assembly. The connection of the vertical profile with the trolleys of the 2Y units is made using right-angle plates (Rollon part# APC-2; for detailed drawings of the plate see page B35). The connection between the 2Y units and the 2X units is obtained using the APF-2 mounting blocks (for mounting instructions of the blocks see previous examples).

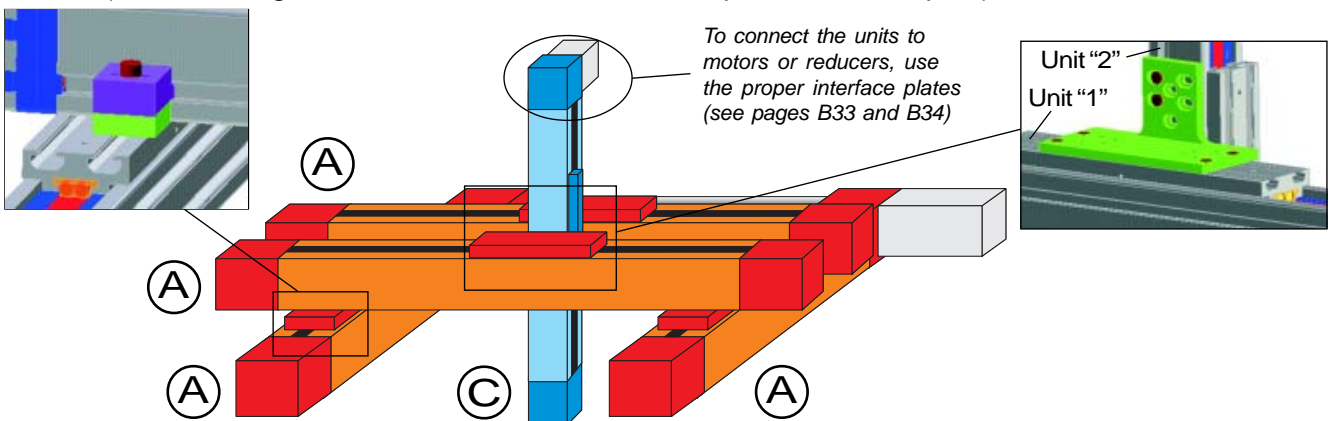

The following are the mounting instructions for the APC-2 plates:

1. Fix the plate to unit 1 trolley by inserting the screws and T-nuts in the proper holes and slots (see Fig.1 as reference). Assure the T-nuts are rotated 90° in their slots when tightened. Recommended tightening torque is 10 Nm (max.)
2. Attach plate to the unit 2 profile (see Fig. 2). Assure the T-nuts are rotated 90° in their slots when tightened. Recommended tightening torque is 10 Nm (max.)

Fig.1

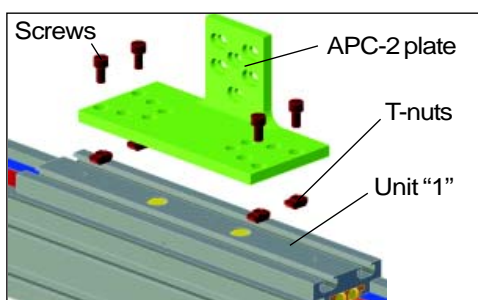
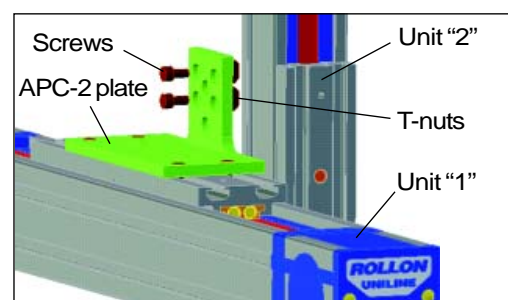

Fig.2



MOTOR / GEARBOX CONNECTION

Proper interface plates must be used in connecting a motor/reducer to the unit.

ROLLON offers these plates in two different types shown on pages B33 and B34.

Whether using **ROLLON**'s or your own plate, ensure that the mounting plate will not interfere with your stroke. Also, it is the customer's duty to ensure that plate and unit will properly support motor/gearbox weight (Call Application Engineering Department for more information).

The metric plate comes with holes that mount to any unit, but they have to be "adapted" to the motor/reducer used (from this point on we will always consider the presence of a reducer between unit and motor). The plates have a centering bore that should be used as a reference when drilling the reducer mounting holes. If the reducer flange covers the "plate-unit" fixing screws, the "plate-reducer" connection must be made by drilling through holes on the reducer and threaded holes on the plate. On the contrary, if the flange leaves enough space to tighten the "plate-unit" screws, depending on the reducer hole type (threaded or not), spot-faced holes on the plate (with the screw head housing on the "unit side") in the first case, or threaded holes in the second case, must be drilled. Once the plates are "adapted" to the reducer, it's possible to start mounting. The mounting procedures will be different depending on the reducer hole type (threaded or not). The following are the mounting instructions:

A) Reducer with threaded holes (use the drawings on pages B33 and B34 as reference):

1. Place the plate against the reducer using the centering bore as reference and fasten using T-nuts and screws.
2. Fix the reducer-plate assembly to the unit's T-slots.
3. Insert the reducer shaft into the pulley housing aligning the key with the keyseat and pushing it until the plate comes in direct contact with the unit.
4. Tighten the screws assuring the T-nuts are rotated 90° in their slots. Recommended tightening torque is 10 Nm (max.)

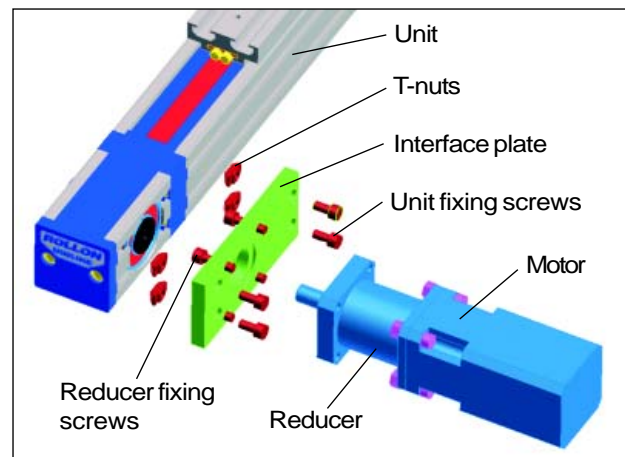

B) Reducer with through holes (use the drawings on pages B33 and B34 as reference):

1. Place the plate against the unit and fasten using T-nuts and screws.
2. Insert the reducer shaft into the pulley housing aligning the key with the keyseat and pushing it until the plate comes in direct contact with the unit.
3. Attach the reducer to the threaded holes of the plate. The interface plates for the **A40** units come with four fixing holes, even if only two of them are used for connection; the other two holes are for symmetry and allow the plate to be used on both sides of the unit.
4. For the "C" family one of the four holes, in particular the one on the upper right corner (see "standard" plate drawing on page B33), is not used for the connection to the unit and must be left without screw and T-nut.

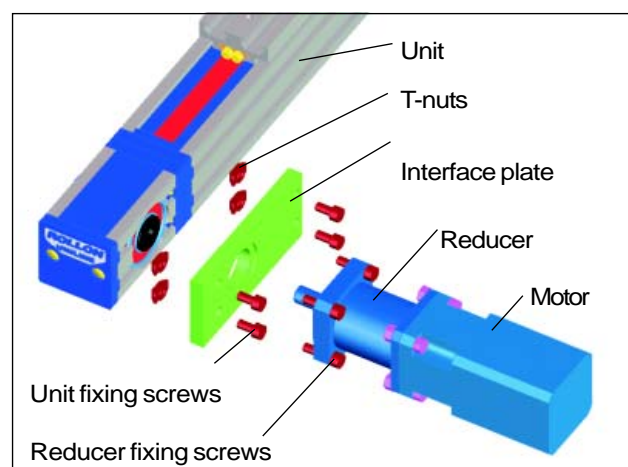

The motor/reducer plates for the **A40** come with four mounting holes even if only two of these are used to mount to the unit. The extra holes make the plate symmetrical and allow it to be used on any side of the unit. For **C** units, only three holes will be used. The upper hole on the body will not be used to mount to the unit.

BELT TENSIONING

The **UNILINE** linear units are all supplied with standard belt tension suitable for most applications. See table below for values.

The belt tension system located at the trolley's end allows different belt tension settings according to technical requirements. For variation please follow procedure below (the reference values are the standard ones).

1. Decide the needed belt tension variation.
2. The number of turns that the tension screws "B" must be turned for the required belt tension variation can be found in the charts below.
3. Calculate the length of the belt (in meters), with the formula:
 $L = 2 \times \text{stroke (m)} + 0.515$ (for "40" size units);
 $L = 2 \times \text{stroke (m)} + 0.630$ (for "55" size units);
 $L = 2 \times \text{stroke (m)} + 0.792$ (for "75" size units).
 $L = 2 \times \text{stroke (m)} + 0.920$ (for "ED75" units).
4. Multiply the numbers of turns (step 2) by the belt length in meters (step 3).
5. Loosen the set-screw "C".
6. Turn the belt tension screws "B" to the value obtained in step 4
7. Fasten the set-screw "C".

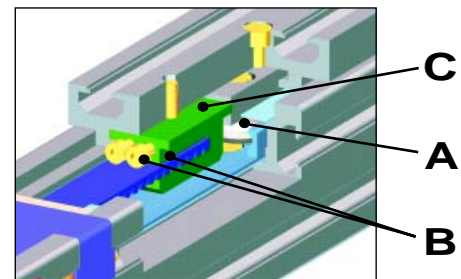
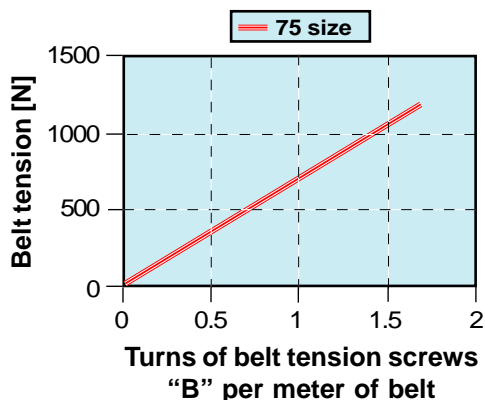
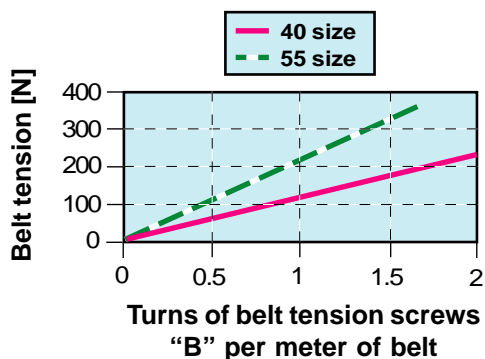

Belt tensioning values

40 size	55 size	75 size	ED75
160 N	220 N	800 N	1000 N

Note: the forces applied on the belt must **never** exceed the belt tension value otherwise the repeatability of position and belt resistance cannot be guaranteed. In case higher tension values are required we suggest contacting our Application Engineering department.

Example:

To increase the belt tension from 220 N to 330 N for a A55-1070:

1. Variation = $330 - 220 = 110$ N.
2. From the chart we find the value of 0.5 turns, which will increase the belt tension by 110 N for every meter of belt.
3. From the formula of step 3, the belt length (in meters) is:
 $L = 2 \times \text{stroke (m)} + 0.630 = 2 \times 1.070 + 0.630 = 2.77$ m.
4. The total number of turns is therefore $0.5 \times 2.77 = 1.4$ turns .
5. Loosen the set-screw "C".
6. Turn the belt tension screws "B" 1.4 turns, using an external reference to obtain a precise setting.
7. Fasten the set-screw "C".

LUBRICATION

UNILINE units are supplied with the internal rails already lubricated to guarantee correct operation without maintenance for a period equal to about 100 km of travel. After this period, it's necessary to maintain the rails to guarantee optimal performance. It is recommended that machines be stopped when performing maintenance.

The lubrication procedure is as follows:

- "C" family units:

1. Move the trolley to one end of the unit.
2. At about half the stroke press and manually move the belt in order to see one of the two rails inside the unit (see figure at right).
3. By using a grease syringe (not supplied by **ROLLON**) or an alternative tool (i.e. brush), apply a conspicuous quantity of grease on the raceways (we suggest a lithium based grease of medium consistency).
4. Move the trolley manually back and forth for the complete stroke in order to distribute the grease on the overall rail length.
5. Repeat the steps 1-4 for the other internal rail.

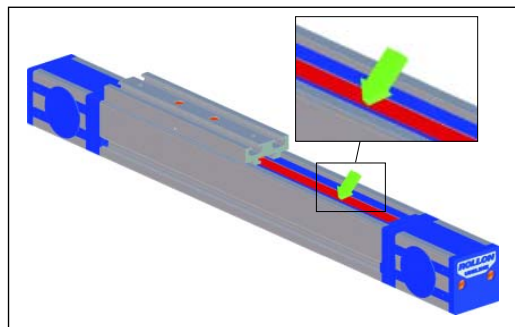

- "A" and "E" family units:

Lubrication of these units is possible by following steps 1-4 of the procedure above. (For the E family, the lubrication of the external rail can be done by following step 3 or any other method). Furthermore, these units also have a lateral hole on the trolley, which allows the grease, by means of a proper conduit, to arrive directly on the raceways of the internal rail. By using this hole, lubrication can be done in two ways:

1. Use of a grease syringe:

When using a grease syringe, insert the needle of the syringe into the hole and then inject the grease in the relative conduit (see figure at right).

Please note that the grease has to fill the whole conduit in order to lubricate the rail properly; for this reason, we recommend a great quantity of grease.

2. Use of an automatic greasing system:

To connect the unit to an automatic greasing system, use a proper adapter/connector that attaches to the threaded hole on the side of the trolley. The advantage of this solution is the possibility of rail re-lubrication without stopping the machine.

It's always recommended (during the maintenance period of the whole machine on which the units are mounted or whenever a machine-stop is foreseen), to clean the rails before lubrication in order to avoid the presence of a great amount of exhausted grease on the inside of the rails.

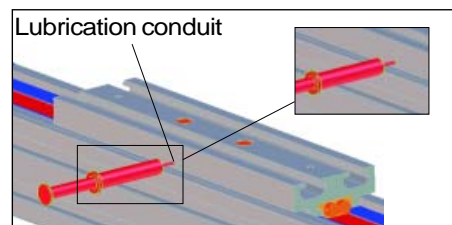

The cleaning can be done as follows:

1. Loosen the set-screws "C" of the belt-tensioning device "A" located on the upper part of the trolley (see figure at right).
2. Loosen completely the belt tensioning screws "B" and remove the tensioning devices.
3. Lift the belt in order to access the internal rails.
4. Clean the rail raceways with a clean and dry cloth, trying to eliminate all the residual grease and dirt that can form during normal operation (move the trolley first to one end of the unit and then to the other, in order to clean the entire rail length).
5. Apply a conspicuous amount of grease on the raceways (in the most preferred way).
6. Re-insert the tensioning devices in their housings, the relative screws and reset the belt tensioning (for this procedure, follow the instructions on page B31).
7. Fasten the set-screws "C".

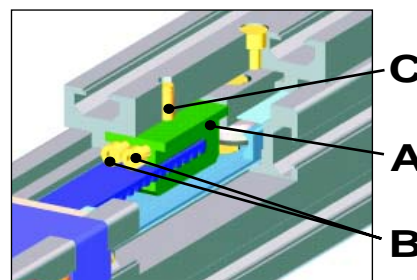

MOUNTING ACCESSORIES

METRIC INTERFACE PLATE

These plates come with the necessary dimensions and proper holes to mount to the units (see drawings). The reducer/motor mounting holes can easily be drilled on the plates by the user to fit most metric reducers/motors.

All plates come with M6 screws and T-nuts for mounting to the units.

Housing for M6 screws
(to be used for fixing on the extrusion slots)

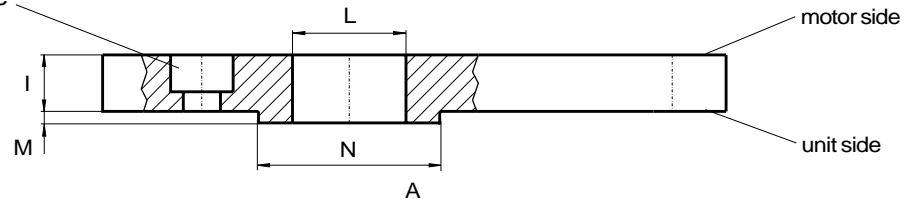

* Area of plate to be removed if used for ED75
(Adding 20 mm to total length of unit will render this modification unnecessary).
x=20; y=35 mm

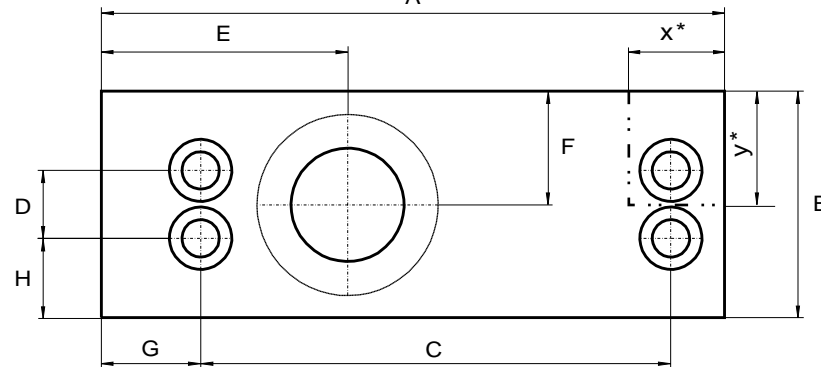

Unit size	Plate code	A [mm]	B [mm]	C [mm]	D [mm]	E [mm]	F [mm]	G [mm]	H [mm]	I [mm]	L [mm]	M [mm]	N [mm]
40	A40-AC2	110	40	83	12	43.5	20	17.5	14	10	Ø 20	2	Ø 32
55	A55-AC2	126	55	100	25	50.5	27.5	18	15	10	Ø 30	2	Ø 47
75	A75-AC2	135	70	106	35	53.5	36	19	18.5	10	Ø 35	2	Ø 55

Order code: A40 - AC2
(A40, A55, A75)

“NEMA” PLATE

These plates mount to the unit and to most standard NEMA sized motors or reducers. (**NEMA 23** for the size 40 families; **NEMA 34** for the size 55 families; **NEMA 42** for the size 75 families). The position of the holes that mount to the unit is identical to those of the “standard” interface plates. All plates come with M6 screws and T-nuts to use in mounting to the units.

Order code: A40 - AC1 - P
(A40, A55, A75)

- "NEMA" plates for "40" and "55" sizes:

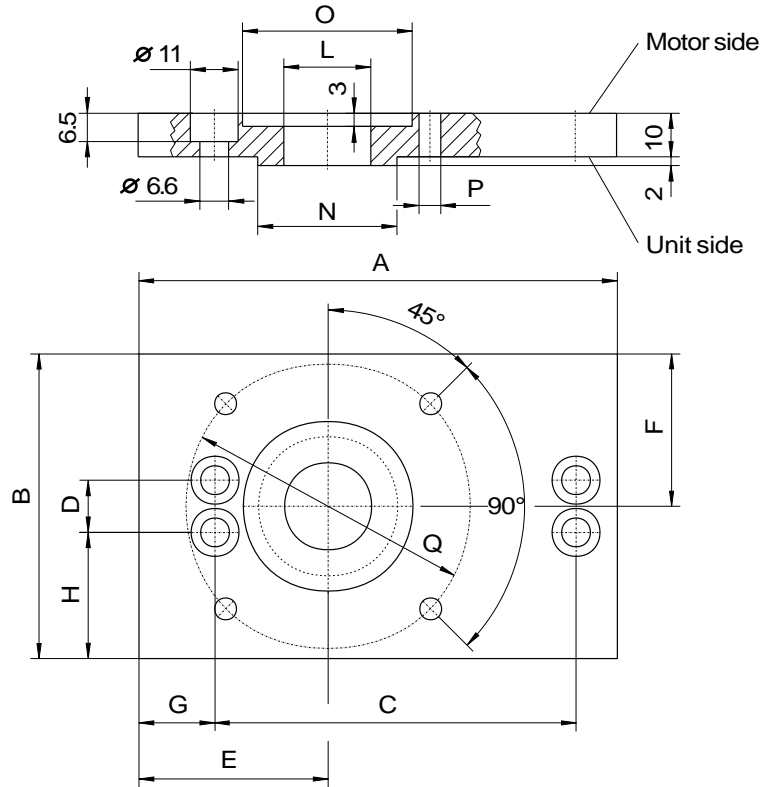

Unit size	Plate code	A [mm]	B [mm]	C [mm]	D [mm]	E [mm]	F [mm]	G [mm]	H [mm]	L [mm]	N [mm]	O [mm]	P [mm]	Q [mm]
40	A40-AC1-P	110	70	83	12	43.5	35	17.5	29	Ø 20	Ø 32	Ø 39	Ø 5	Ø 66.7
55	A55-AC1-P	126	100	100	25	50.5	50	18	37.5	Ø 30	Ø 47	Ø 74	Ø 5.5	Ø 98.4

- "NEMA" plate for "75" size:

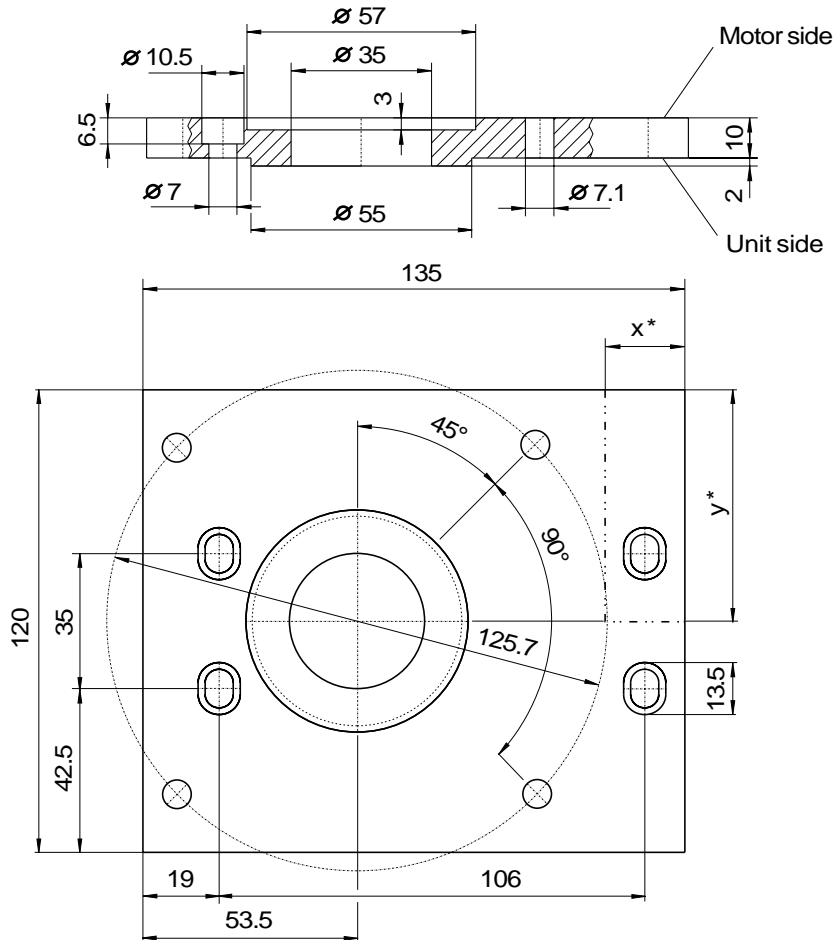

* Area of plate to be removed if used for ED75 (Adding 20 mm to total length of unit will render this modification unnecessary).
x=20; y=60 mm

“T” PLATE

This plate allows two units to be mounted perpendicular to each other as in the example on pages B26 and B29. The plate will not interfere with the strokes of either unit.

It comes with M6 screws and T-nuts for mounting.

This plate cannot be used for ED75 unit! (Please consult our Application Engineering Department for more information).

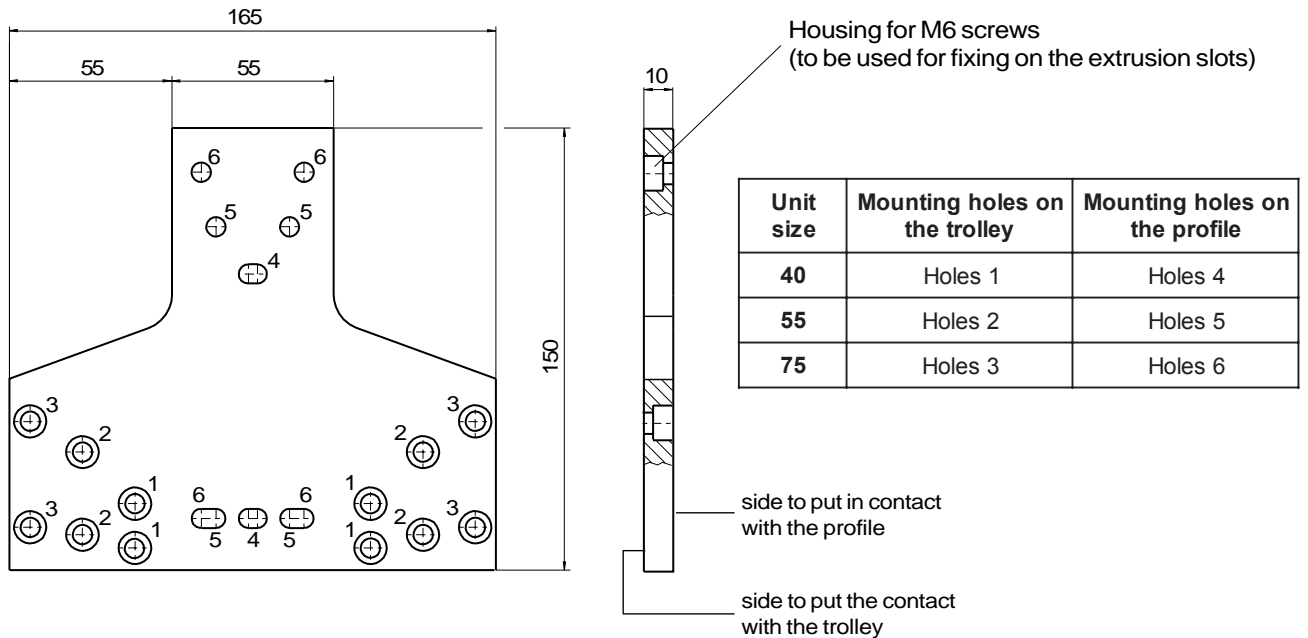

Order code: APC - 1

“RIGHT ANGLE” PLATE

This plate allows the right angle mounting of two units. The trolley of one unit can be mounted to the side of the other as in the example on page B29. The plate will not interfere with the strokes of either unit. It comes with M6 screws and T-nuts for mounting.

This plate cannot be used for ED75 unit! (Please consult our Application Engineering Department for more information).

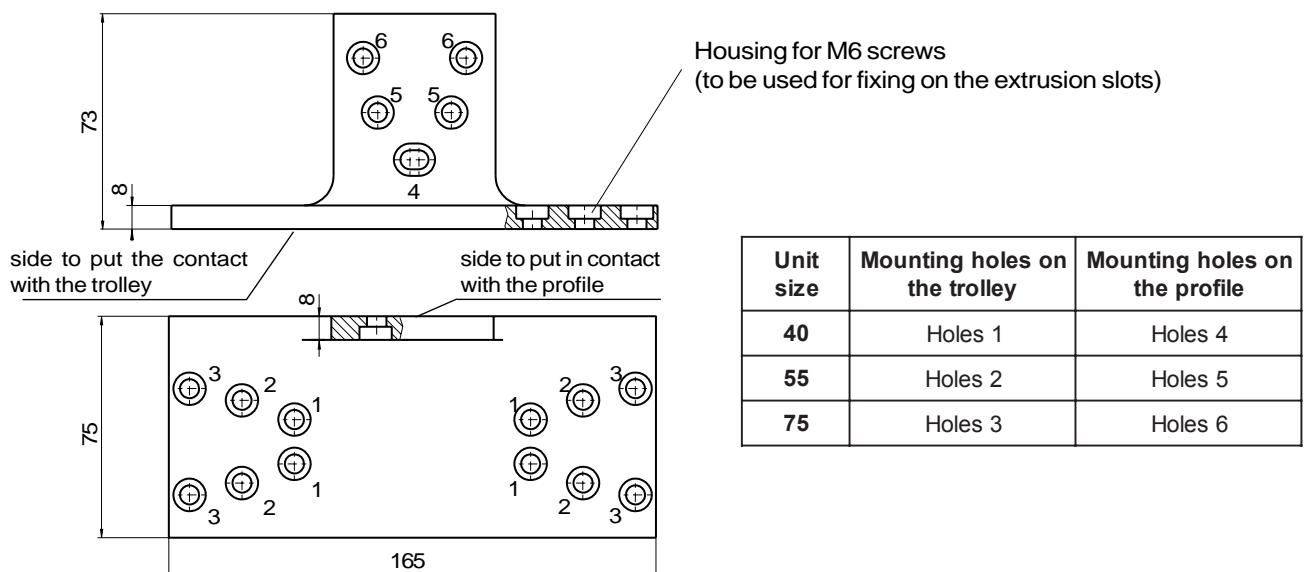

Order code: APC - 2

“X” PLATE

This plate allows two units to be mounted perpendicular to each other as in the examples on pages B28 and B29. The plate will not interfere with the strokes of either unit. It comes with M6 screws and T-nuts for mounting.

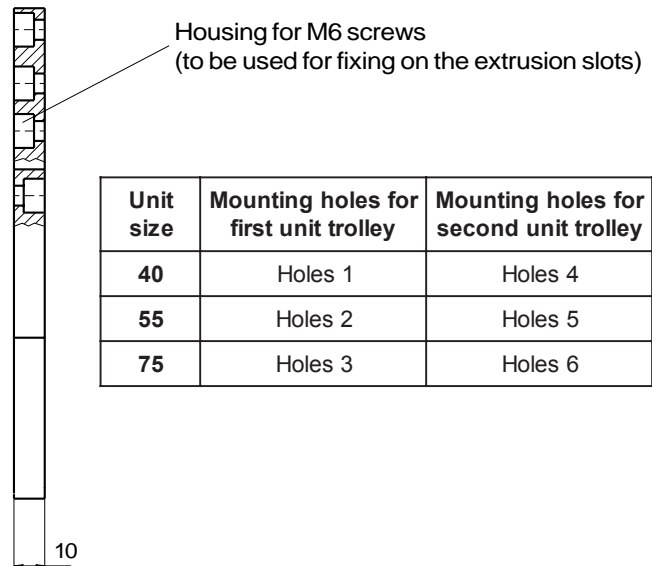
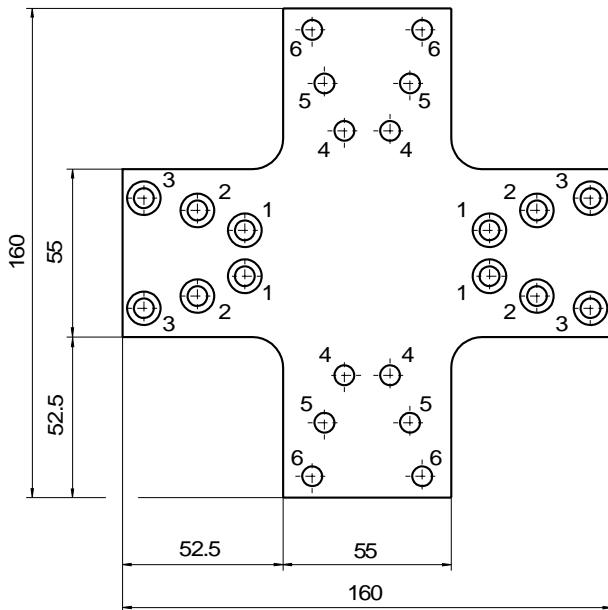

Unit size	Mounting holes for first unit trolley	Mounting holes for second unit trolley
40	Holes 1	Holes 4
55	Holes 2	Holes 5
75	Holes 3	Holes 6

Order code: APC - 3

MOUNTING BLOCK

Multiple mounting blocks are used to mount a unit to a mounting surface. They can also be used to mount two units together with or without an interface plate (see examples on pages B27, B28 and B29). The blocks will fit in any of the T-slots in each of the units.

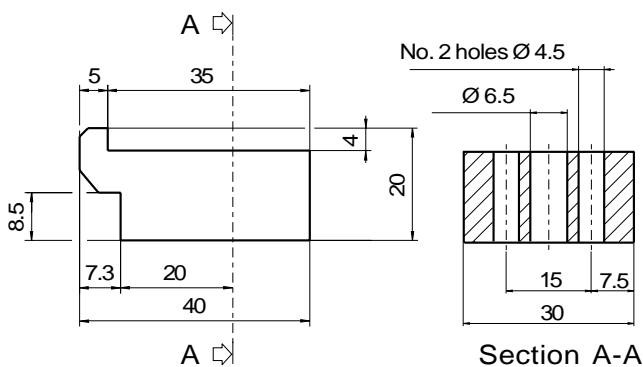

- Insert the projecting part of the mounting block into the lower slot of the unit aluminum profile;
- Position the block longitudinally, in accordance with the holes position on the supporting structure. Insert, if necessary, a shim (not supplied) between the block and the supporting plane;
- Insert the screw/screws into the block and tighten.

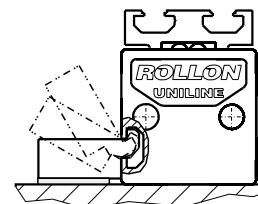

Order code: APF - 2

T-NUTS

All **UNILINE** unit profiles have 8 mm slots, in which it's possible to use T-nuts with M4, M5 and M6 holes. **ROLLON** can supply sets of 100 pieces of T-nuts with M6 holes. Recommended tightening torque is 10 Nm (max.)

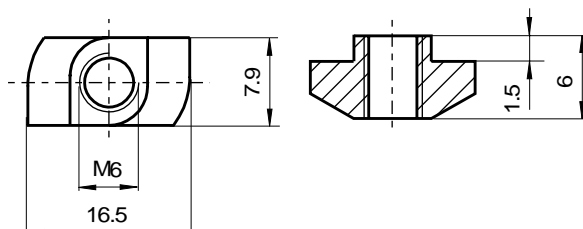

Order code:

KIT - 4 (set of 100 pcs.)

OTHER USEFUL INFORMATION

RUNNING PARALLELISM

Running parallelism for all standard families and sizes is equal to 0.8 mm (see drawing below):

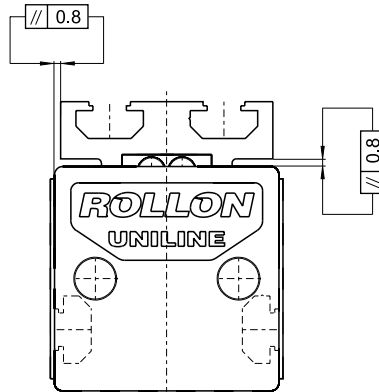

REPEATABILITY OF POSITIONING

Repeatability of positioning is equal to 0.1 mm for all standard families and sizes.

UNITS USED IN PAIRS

When multiple units are to be mounted parallel and run together using a connecting shaft, indicate in the order that **the key slots of the pulleys must be synchronized**.

EXTRA LONG UNITS

Units of considerable length are possible. These units are sometimes difficult to transport and may have to be shipped disassembled. Please contact our Application Engineering department for more information.

DIMENSIONAL TOLERANCES ON STROKES AND LENGTHS

In order to always guarantee the minimum stroke required, the actuators will have positive tolerances. These tolerances can be quantified relative to the stroke of the unit:

For strokes < 1m: +0; +10mm;

For strokes > 1m: +0; +15mm;

For strokes greater than standard, the tolerances could be slightly higher.

WORKING TEMPERATURE

The working temperature range is -20°C / +80°C (-4°F / +176°F).

LINEAR ACTUATOR A100C

The **ROLLON** linear actuator simply and reliably solves the problems of a moving axis. Fully interlocked multi-axis robots can be quickly established by fixing one or more actuators to a basic structure and then adding motors and drive controls.

The Problem

Up to now, linear actuator could be divided into two categories: units using ball recirculating systems and units using rollers. Although the ball recirculating actuators offer high load capacity and stiffness, they are generally oversized compared to their structural profile. They are very noisy and unable to work at high speed because of the constraints inherent in the ball recirculating system. Until now, actuators using rollers, while capable of high speed and less noise, have been undersized compared to their structural profile and limited by low load capacity and moderate stiffness. The most complete versions have rollers made by profiled ball bearings running on steel rods which are only partially sunk into the outside of the structural profile and therefore remain visible.

In general, rollers are no more than plastic covered ball bearings running directly onto aluminum.

ROLLON's solution

The original design of the **ROLLON** linear actuator **A100C** has been achieved after extensive development and use of FEM techniques. The **A100C** combines the high load capacity, stiffness and compactness of a ball recirculating actuator with the high speed and low noise of a actuator with rollers. The result is an optimal integration of structural profile, rail and linear slide.

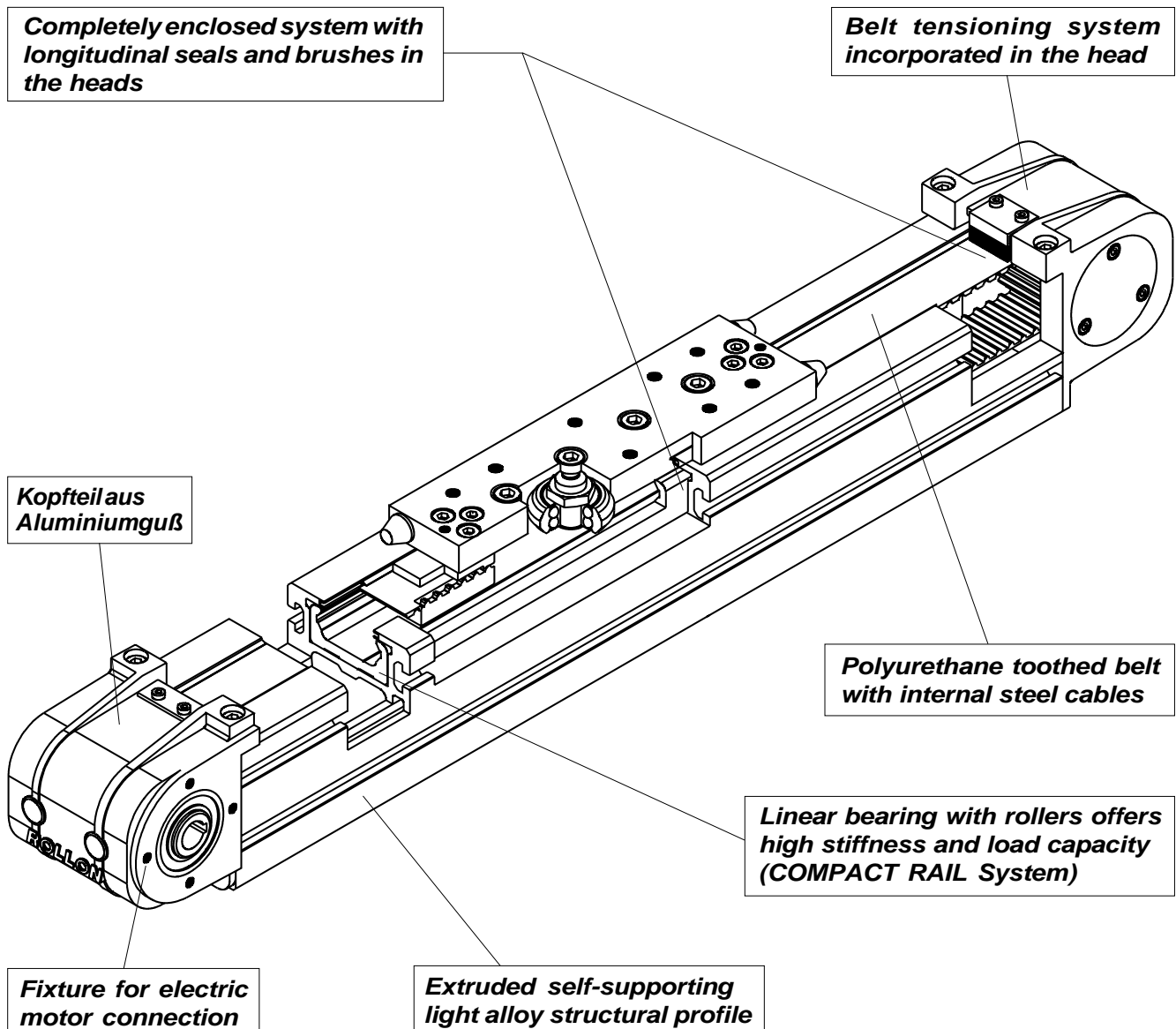

The linear slide inside the actuator is from the **ROLLON COMPACT RAIL** system, which is based on the original concept of a slider with rollers running **inside** a carbon steel channel-shaped rail. The raceways are induction hardened and positioned internally for protection. The section, the rail profile and slider rollers have been optimised using FEM techniques. The rollers comprise a precision double row angular contact ball bearing with an internal eccentric pivot. The extra-thick outer ring is profiled for optimum running inside the rail. The result is a slide-roller system having high axial/radial load capacity and high stiffness. The internal eccentric pivots allow adjustment of the rollers in order to achieve a required preload suited to the application. The extruded structural profile has been carefully proportioned to obtain a balance between stiffness of the slide and stiffness of the profile. The external sides of the structural profile have tee slots to allow the actuator to be easily fixed to support structures or other profiles. Transmission is achieved by using a polyurethane toothed belt of the AT series, which has been reinforced with internal steel cables to give low extension, very high stiffness, resistance to wear and reliability with a no-maintenance guarantee. The motor heads are aluminum castings. One incorporates the belt tension system, while the other contains the driving pulley and the fixtures for the attachment of the motor on both sides. The linear actuator is available in two versions:

- **Version A:** The driving pulley is fitted with a hollow shaft with a key slot. If the application requires a double projecting shaft solution, a slotted shaft (included with the unit) may be inserted into the hollow shaft.

- **Version B:** The driving pulley is fitted with a smooth hollow shaft that can be attached to the motor by compression coupling.

The mechanical movement is completely protected by longitudinal seals and brushes in the heads.

Dimensions

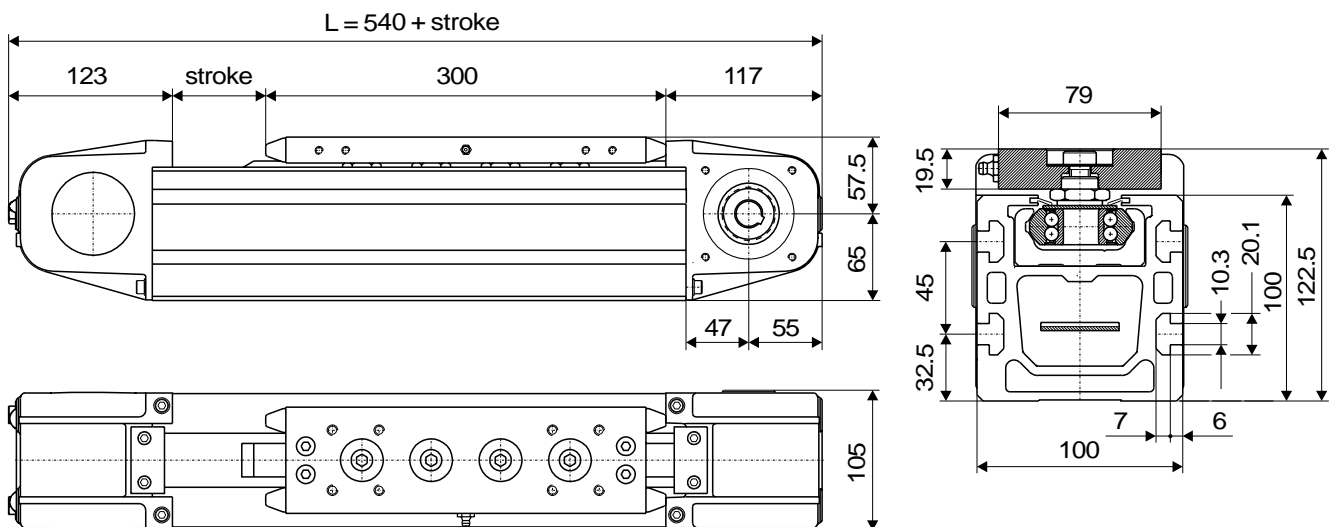

Attachments on the slider

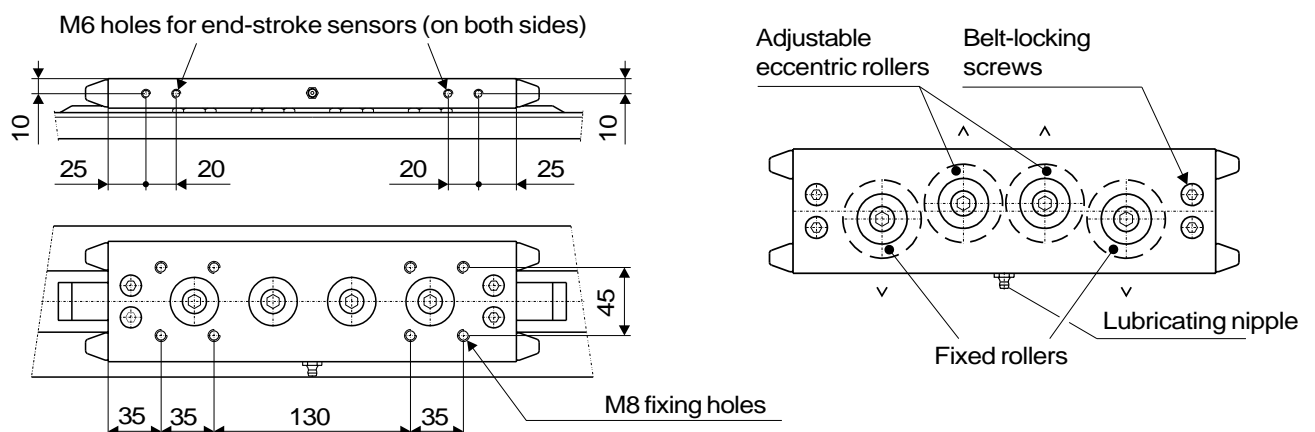

Motor connections: version A

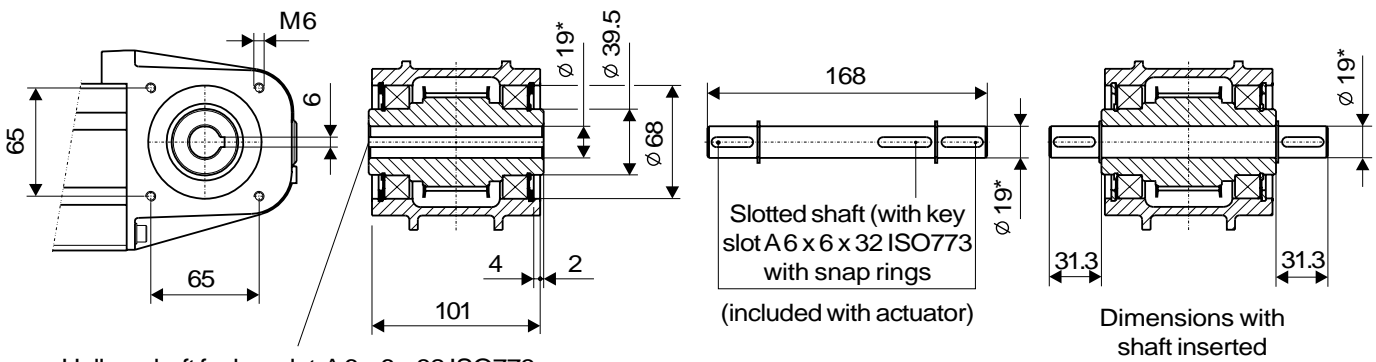

* $\varnothing 20$ mm available upon request!

Version A offers two possibilities:

- a) the hollow shaft with the key slot allows direct connection through an appropriate interface plate to a motor (or reducer) with a projecting shaft.
- b) inserting the slotted shaft into the hollow shaft of the driving pulley, a motor and an eventual intermediate shaft can be connected to the head by a sleeve joint giving a double projecting shaft solution. In this case a joining box containing the sleeve joint must be obtained.

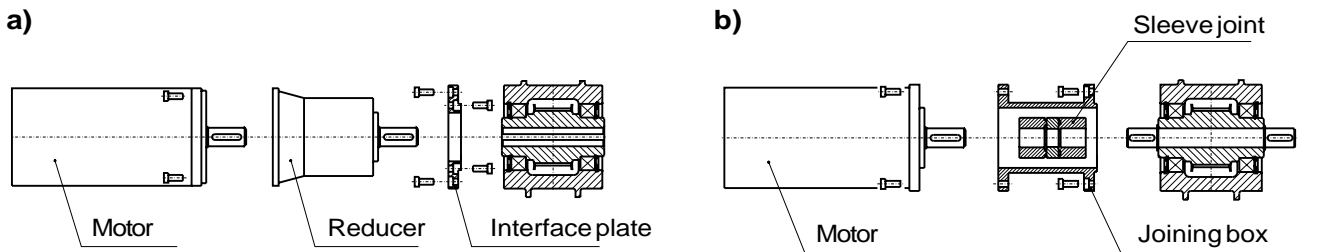

Motor connections: version B

The smooth hollow shaft allows the driving pulley to be connected to the motor shaft by compression coupling. If the motor shaft is $\varnothing 19$, ROLLON's compression coupling (available as an accessory, see **Accessories**) can be attached to the inside of the hollow shaft, avoiding unnecessary encumbrance between the motor and the head.

In this case an appropriate interface plate, connecting the coupling flange of the motor to the motor head, must be procured.

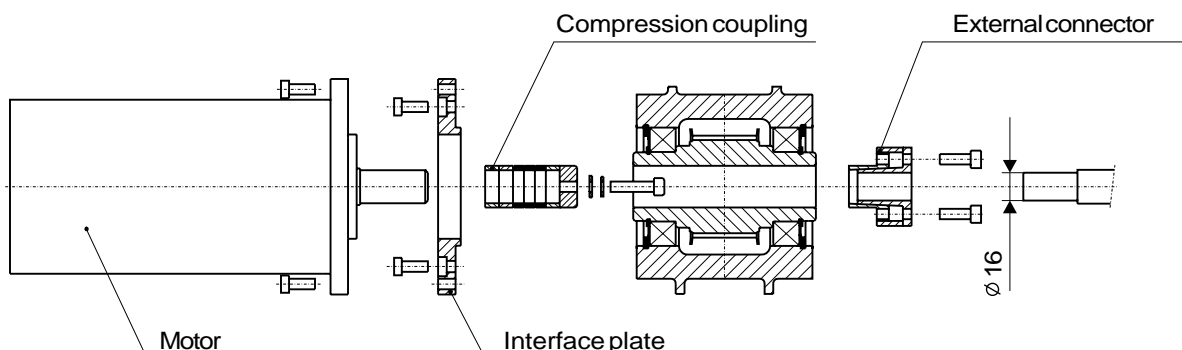
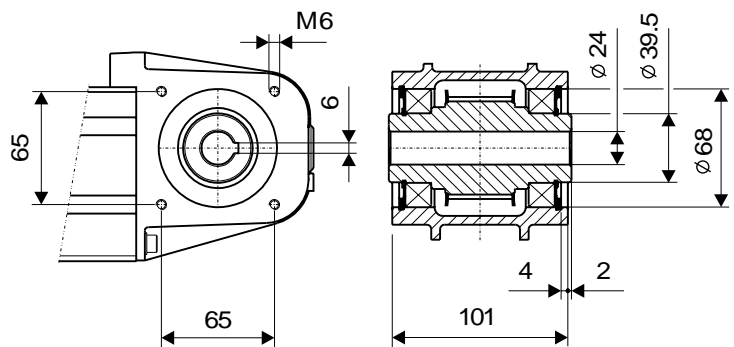

Notes

The linear actuator is supplied with a factory assembled and adjusted slider, in order to obtain the smoothest slide without play; this adjustment is suitable for the majority of applications. If needed, it's possible to modify the adjustment by acting on the two central rollers (ask for information from the **ROLLON** Technical Service).

The belt has a factory preload of 1000 N per arm, but can be adjusted using the two regulating screws on the tension head.

The belt preload value must be determined in function of the force acting on the belt when working.

To obtain the best position precision, the belt tension must always be greater than the force transmitted, depending on the loads applied and the unit's law of motion. If the belt preload is changed, the correct alignment of the driven pulley can be verified by removing the lids on the sides of the head (ask for information from the **ROLLON** Technical Service).

The torque applied to the drive pulley, necessary to move a loadless slider horizontally with standard belt tension, is equal to 2.3 Nm. If the belt tension is increased, the torque required increases.

Accessories

Compression coupling

Order code: **AC-10MA01**

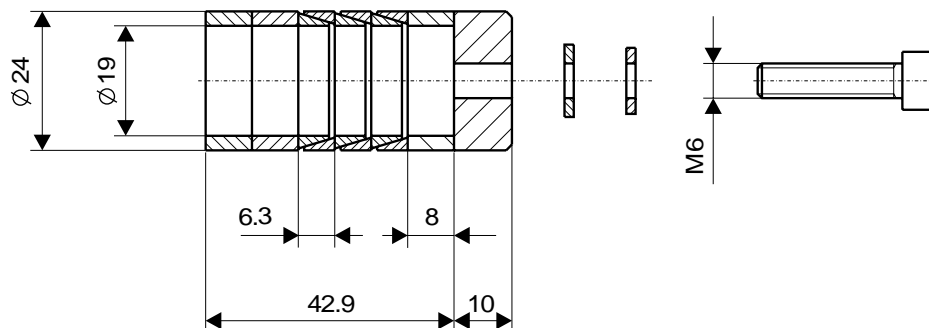

Max torque transmissible: 63 Nm

Technical characteristics of the standard version

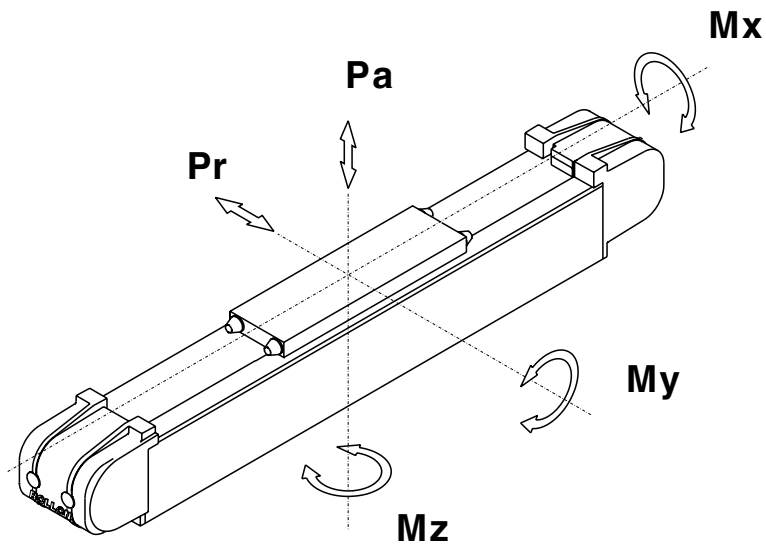

Axial Load P_a (N)	7200
Radial Load P_r (N)	12500
Allowable Moment M_x (Nm)	250
Allowable Moment M_y (Nm)	250
Allowable Moment M_z (Nm)	600
Moment of Inertia I_x (cm ⁴)	400
Moment of Inertia I_y (cm ⁴)	500
Max. Belt Tractive Force (N)	5000
Positioning Precision (mm)	0.1
Max. Speed (m/s)	9
Primitive Diameter of Drive Pulley (mm)	60.48
Stroke per Shaft Revolution (mm)	190
Mass of Slider (kg)	4.2
Mass of Belt (kg)	0.17 + (0,44 x Stroke in m)
Idle Torque (Nm)	2.3
Total Moment of Inertia of Mass (kgmm ²) (of both pulleys)	660
Working Temperature	-20°C +85°C

Special versions

Special versions of linear actuator with a longer slider or with two sliders can be provided upon request.

Linear actuator with long slider (A100CL)

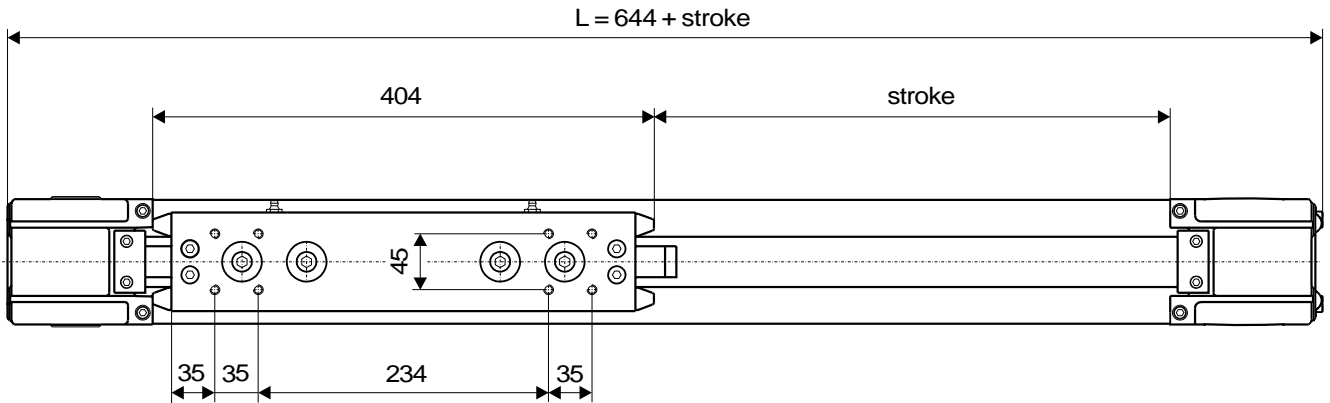

This actuator offers higher load moments due to the extended length of the slider.

<i>Technical characteristics differing from standard version</i>	
Mass of slider (kg)	5.5
Allowable Moment M_y (Nm)	500
Allowable Moment M_z (Nm)	1200

Linear actuator with two sliders (A100CD)

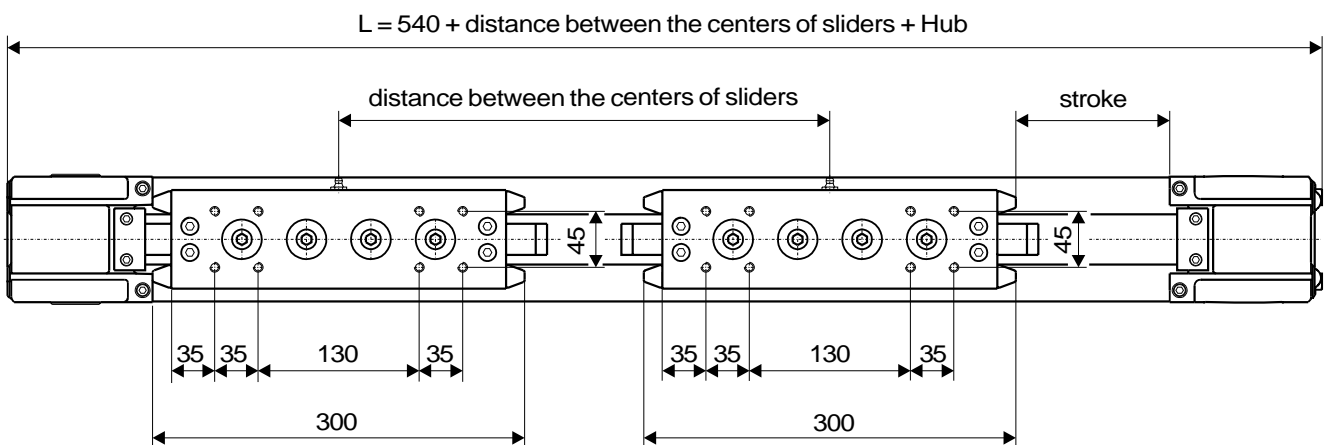

This actuator offers notably higher M_y and M_z load moments which vary in function of the distance between the centers of the sliders.

<i>Technical characteristics differing from standard version</i>	
Axial Load Capacity P_a (N)	14400
Radial Load Capacity P_r (N)	25000
Allowable Moments M_x (Nm)	500
Total mass of sliders (kg)	8.4

Order codes

Standard linear actuator A100C

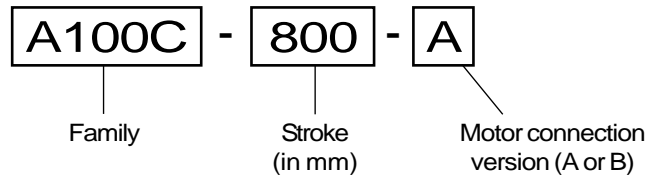

The **available strokes** are from **170** to **3420** mm, with intermediate sizes every 50 mm.

Linear actuator with long slider A100C...L

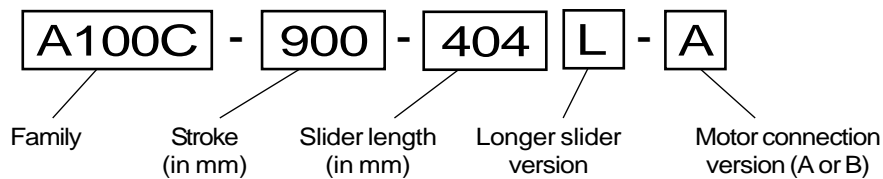

The **available strokes** are from **166** to **3316** mm, with intermediate sizes every 50 mm.

Linear actuator with two sliders A100C...D

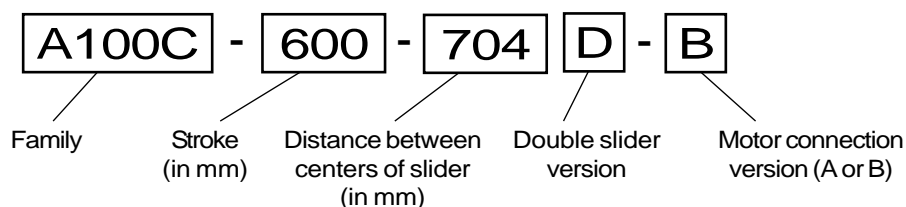

The **available strokes** are from **174** to **3024** mm, with intermediate sizes every **50** mm.

The **distances available between the centers of the sliders** are from **396** to **996** mm, with intermediate sizes every 50 mm.

The sum of the stroke and the distance between the sliders cannot be more than 3420 mm.