

Rod Ends

Female

Self-aligning bearing used for control linkages. Able to take tensile and compressive loads, steel on composite, complete with lubricating nipple.

- Body: Carbon steel S45C (C45 Din)
- Ball: Carbon chrome steel S45C (100Cr6)
- Bush: Cu-Zn alloyed brass

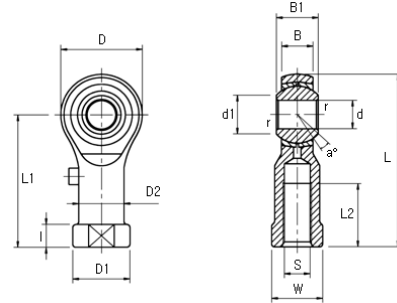

JF

Available in left and right hand threads

	Thread		Dimensions (mm)													Angle	Static Load	Mass
	d	Thread	D	B	B1	d1	L	l	L1	L2	W	D1	D2	r	a	Co(Kgf)	gr.	
JF5	5	M5X.8	16	6	8	7.7	35.1	4	27.1	14	9	11	9	0.5	13	570	16.5	
JF6	6	M6X1	18.5	6.75	9	9	39.35	5	30.1	14	11	13	10	0.5	13	700	25	
JF8	8	M8X1.25	23	9	12	10.4	49.1	6	37.5	17	14	16	12.5	0.5	13	1000	43	
JF10	10	M10X1.5	27	10.5	14	12.9	58.6	8	44.6	21	17	19	15	0.5	13	1350	72	
JF10-1.25		M10X1.25																
JF12	12	M12X1.75	31	12	16	15.8	67.1	7.5	51.6	24	19	22	17.5	0.5	13	1700	107	
JF12-1.25		M12x1.25																
JF14	14	M14X2	34	13.5	19	16.9	75.2	9	58.2	27	22	25	20	0.5	15	2100	160	
JF14-1.50		M14X1.5																
JF16	16	M16X2	38	15	21	19.3	84.7	9.5	65.7	33	24	27	22	0.5	15	2550	210	
JF16-1.50		M16X1.5																
JF18	18	M18X1.5	43	16.5	23	21.7	93.2	10	71.7	36	27	31	25	0.5	15	3000	295	
JF20	20	M20X1.5	46	18	25	23.8	101.2	11	78.2	40	30	34	27.5	0.5	15	3500	380	
JF22	22	M22X1.5	52	20	28	25.8	110.2	12	84.2	43	32	37	30	0.5	15	4200	490	
JF24	25	M24X2	60	22	31	29.8	124.2	12	94.2	50	36	42	33.5	0.5	15	7400	750	
JF24-1.50		M24X1.5																
JF25	25	M25X1.5	60	22	31	29.8	124.2	12	94.2	50	36	42	33.5	0.5	15	7400	750	
JF26	25	M26X1.5	60	22	31	29.8	124.2	12	94.2	50	36	42	33.5	0.5	15	7400	750	
JF30	30	M30X2	73	21	32	34.4	145.3	16.5	108.8	50	47	49	40	0.5	15	9100	900	
JF30-1.50		M30X1.5																
JF35	35	M36X2	82	23	35	39.8	173.3	17	132.3	60	49	58	48	0.5	15	11400	1400	
JF35-1.50		M36X1.5																

Rod ends from 20mm and above have steel on steel spherical plain bearings.

JF3/16	3/16	#10X32	17	6	8	7.7	35	4	26.5	14	9	11	9	0.5	13	570	16.5
JF1/4	1/4	1/4X28	18.5	6.75	9	9	39.2	5	30	14	11	13	10	0.5	13	700	25
JF5/16	5/16	5/16X24	23	9	12	10.4	49	6	37.5	17	14	16	12.5	0.5	13	1000	43
JF3/8	3/8	3/8X24	27	10.5	14	12.9	58.5	8	45	21	17	19	15	0.5	13	1350	72
JF7/16	7/16	7/16X20	31	12	16	15.8	67	7.5	51.5	24	19	22	17.5	0.5	13	1700	107
JF1/2	1/2	1/2X20	31	12	16	15.8	67	7.5	51.5	24	19	22	17.5	0.5	13	1700	107
JF5/8	5/8	5/8X18	38	15	21	19.3	84.5	9.5	65.5	33	24	27	22	0.5	15	2550	210
JF3/4	3/4	3/4X16	46	18	25	23.8	101	11	78	40	30	34	27.5	0.5	15	3500	380
JF7/8	7/8	7/8X14	52	20	28	25.8	110	12	84	43	32	37	30	0.5	15	4200	490
JF1	1	1X12	60	22	31	29.6	124	12	94	50	36	42	33.5	0.5	15	5500	750

Normal stock items are in bold type

A



Male

Self-aligning bearing used for control linkages. Able to take tensile and compressive loads, steel on composite, complete with lubricating nipple.

- Body: Carbon steel S45C (C45 Din)
- Ball: Carbon chrome steel S45C (100Cr6)
- Bush: Cu-Zn alloyed brass



JM

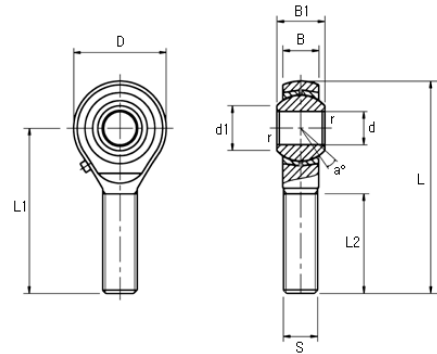

Available in left and right hand threads

	Thread		Dimensions								Angle	Static Load	Mass
	d	Thread	D	B	B1	d1	L	L1	L2	r	a	Co(Kgf)	gr.
JM5	5	M5X.8	17	6	8	7.7	42.5	34	20	0.5	13	350	12.5
JM6	6	M6X1	18.5	6.8	9	9	47.5	36.9	22	0.5	13	500	19
JM8	8	M8X1.25	23	9	12	10.4	54.5	43	25	0.5	13	700	32
JM10	10	M10X1.5	27	10.5	14	12.9	62.5	49	29	0.5	13	1100	54
JM12	12	M12X1.75	32	12	16	15.8	73.3	57.3	33	0.5	13	1700	85
JM14	14	M14X2	34	13.5	19	16.9	80.8	63.8	36	0.5	15	2100	126
JM16	16	M16X2	38	15	21	19.3	87.3	68.3	40	0.5	15	2550	185
JM18	18	M18X1.5	43	16.5	23	21.9	95.3	73.8	44	0.5	15	3000	260
JM20	20	M20X1.5	46	18	25	23.9	103.5	80.5	47	0.5	15	3500	340
JM22	22	M22X1.5	52	20	28	25.8	112.8	86.8	51	0.5	15	4200	435
JM24	25	M24X2	60	22	31	29.8	126.8	98.8	57	0.5	15	7400	650
JM25	25	M25X.15	60	22	31	29.8	126.8	98.8	57	0.5	15	7400	650
JM30	30	M30X2	73	21	32	34.4	147.8	111.3	66	0.5	15	9100	910
JM35	35	M36X2	82	23	35	39.8	176.2	135.2	80	0.5	15	11400	1440

Rod ends from 20mm and above have steel on steel spherical plain bearings.

JM3/16	3/16	#10X32	17	6	8	7.7	42.5	34	20	0.5	13	350	12.5
JM1/4	1/4	1/4X28	18.5	6.8	9	9	46	36.73	22	0.5	13	500	19
JM5/16	5/16	5/16X24	23	9	12	10.4	54	42.5	25	0.5	13	700	32
JM3/8	3/8	3/8X24	27	10.5	14	12.9	62	48.5	29	0.5	13	1100	54
JM7/16	7/16	7/16X20	32	12	16	15.8	73	57	33	0.5	13	1700	85
JM1/2	1/2	1/2X20	32	12	16	15.8	73	57	33	0.5	13	1700	85
JM5/8	5/8	5/8X18	38	15	21	19.3	86.5	67.5	40	0.5	15	2550	185
JM3/4	3/4	3/4X16	46	18	25	23.9	103	80	47	0.5	15	3500	340
JM7/8	7/8	7/8X14	52	20	28	25.8	112	86	51	0.5	15	4200	435
JM1	1	1X12	60	22	31	29.8	126	96	57	0.5	15	5500	600

Normal stock items are in bold type.

Fine pitch metric male are available in stainless steel.

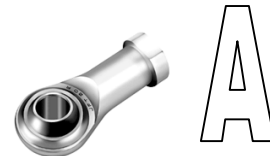

Teflon Liner

Self lubricating PTFE liner
Low friction, minimal maintenance
and water resistance

Available in left and right hand
threads.

-200°C - +260°C temperature
rating.



JFT

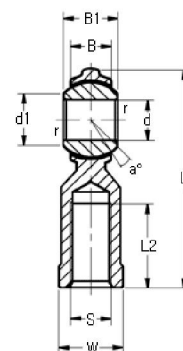
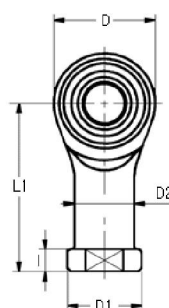

	Thread		Dimensions												Angle	Static Load	Mass
	d	Thread	D	B	B1	d1	L	l	L1	L2	W	D1	D2	r	a	Co(Kgf)	gr.
JFT5	5	M5X.8	16	6	8	7.7	35	4	27	14	9	11	9	0.5	13	400	16.5
JFT6	6	M6X1	18	6.75	9	9	39	5	30	14	11	13	10	0.5	13	510	25
JFT8	8	M8X1.25	23	9	12	10.4	47	5	35.5	17	14	16	13	0.5	13	760	43
JFT10	10	M10X1.5	27	10.5	14	12.9	56	7	42.5	21	17	19	15	0.5	13	960	72
JFT10-1.25		M10X1.25															
JFT12	12	M12X1.75	31	12	16	15.8	66	7.5	50.5	24	19	22	17.5	0.5	13	1120	107
JFT12-1.25		M12x1.25															
JFT14	14	M14X2	35	13.5	19	16.9	75	8.5	57.5	27	22	25	20	0.5	15	1550	160
JFT14-1.50		M14X1.5															
JFT16	16	M16X2	39	15	21	19.3	83	8.5	63.5	33	24	27	22	0.5	15	2060	210
JFT16-1.50		M16X1.5															
JFT18	18	M18X1.5	43	16.2	23	21.7	92	10	71.5	36	27	31	25	0.5	15	2570	295
JFT20	20	M20X1.5	46	18	25	23.8	101	11	78	40	30	34	27.5	0.5	15	2840	380

Self lubricating PTFE liner
Low friction, minimal maintenance
and water resistance

Available in left and right hand
threads.

-200°C - +260°C temperature
rating.



JMT

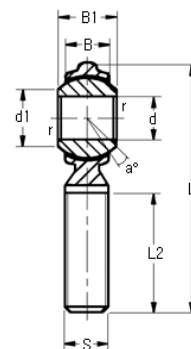
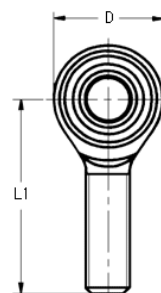

	Thread		Dimensions										Angle	Static Load	Mass
	d	Thread	D	B	B1	d1	L	L1	L2	r	a	Co(Kgf)	gr.		
JMT5	5	M5X.8	17	6	8	7.7	42	33.5	20	0.5	13	350	12.5		
JMT6	6	M6X1	18.5	6.75	9	9	46	36.75	22	0.5	13	500	19		
JMT8	8	M8X1.25	23	9	12	10.4	53	41.5	25	0.5	13	700	32		
JMT10	10	M10X1.5	27	10.5	14	12.9	61	47.5	26.5	0.5	13	960	54		
JMT12	12	M12X1.75	31	12	16	15.8	69	53.5	33	0.5	13	1120	85		
JMT14	14	M14X2	35	13.5	19	16.9	76.5	59	36	0.5	15	1550	126		
JMT16	16	M16X2	39	15	21	19.3	85	65.5	40	0.5	15	2060	185		
JMT18	18	M18X1.5	43	16.2	23	21.7	94.5	73	44	0.5	15	2570	260		
JMT20	20	M20X1.5	46	18	25	23.8	103	80	47	0.5	15	2840	340		

A



Stainless Rod Ends Metric

Stainless steel 306 body with PTFE liner. Ball 440C heat-treated.

Left and right hand available.

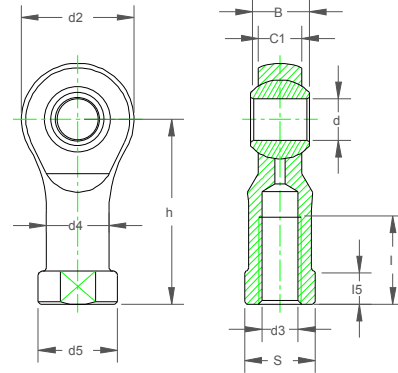

	Dimensions												angle	Static load Co (Kgf)	Mass gr.
	d	B	c1	d2	d3	h	I	d4	d5	I5	S				
JF TS5	5	8	6	20	M 5x0.8	29	9	10	13	5	8	9	350	16.5	
JF TS6	6	9	7.5	20	M 6x1	30	9	10	13	5	10	9	500	25	
JF TS8	8	12	9.5	24	M 8x1.25	36	12	12.5	16	5	13	12	700	43	
JF TS10	10	14	11.5	30	M 10x1.5	43	15	15	19	6.5	16	10	1100	72	
JF TS10-1.25P	10	14	11.5	30	M 10x1.25	43	15	15	19	6.5	16	10	1100	72	
JF TS12	12	16	12.5	34	M 12x1.75	50	18	17.5	22	6.5	18	12	1700	110	
JF TS12-1.25P	12	16	12.5	34	M 12x1.25	50	18	17.5	22	6.5	18	12	1700	110	
JF TS14	14	19	13.5	34	M 14x2	57		20	25	8	22	14	2100	160	
JF TS14-1.5P	14	19	13.5	34	M 14x1.5	57		20	25	8	22	14	2100	160	
JF TS16	16	21	15.5	42	M 16x2	64	24	22	27	8	24	14	2550	210	
JF TS16-1.5P	16	21	15.5	42	M 16x1.5	64	24	22	27	8	24	14	2550	210	
JF TS18-1.5P	18	23	16.5	42	M 18x1.5	71		25	31	10	27	15	3000	295	
JF TS20	20	25	18.5	50	M 20x1.5	77	30	27.5	34	10	30	15	3500	380	
JF TS24	25	31	22	60	M 24x2	94	45	34	43	14	36	15	4000	725	

Stainless steel 306 body with PTFE liner. Ball 440C heat-treated.

Left and right hand available.

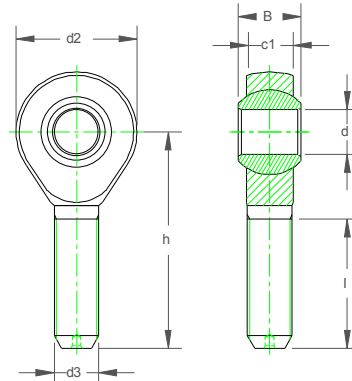

	Dimensions							angle	Static load Co (Kgf)	Mass gr.
	d	B	c1	d2	d3	h	I			
JM TS5	5	8	5.5	20	M 5x0.8	32	20	9	350	16.5
JM TS6	6	9	7.5	20	M 6x1	36	21	9	500	19
JM TS8	8	12	9.5	24	M 8x1.25	41	25	12	700	32
JM TS10	10	14	11.5	30	M 10x1.5	47	28	10	1100	54
JM TS10-1.25P	10	14	11.5	30	M 10x1.25	47	28	10	1100	54
JM TS12	12	16	12.5	34	M 12x1.75	53	32	12	1700	85
JM TS12-1.25P	12	16	12.5	34	M 12x1.25	53	32	12	1700	85
JM TS14-1.5	14	21	13.5	39	M 14x1.5	59	36	14	1850	126
JM TS16	16	21	15.5	42	M 16x2	65	37	14	2550	185
JM TS16-1.5P	16	21	15.5	42	M 16x1.5	65	37	14	2550	185
JM TS18	18	23	16	46	M 18x1.5	72	42	14	3000	220
JM TS20	20	25	18.5	50	M 20x1.5	80	45	14	3500	340
JM TS22	22	28	20	54	M 22x1.5	85	52	14	3750	450



Stainless Rod Ends Imperial

Stainless steel 306 body with PTFE liner. Ball 440C heat-treated.

Left and right hand available.

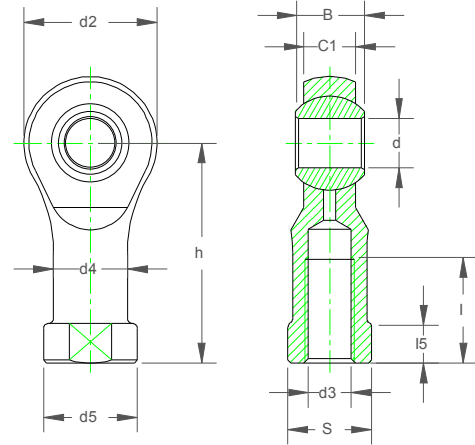

	Dimensions											Static Load kgf		Weight (gr)	
	d	B	C1	d2	h1	l3	d5	S	d4	l5	Ball Dia	Thread	Radial		Axial
JFTS3/16	0.19	0.312	0.25	0.625	1.062	0.562	0.406	0.312	0.312	0.187	0.4375	0.19 UNF-32	614	226	14
JFTS1/4	0.25	0.375	0.281	0.75	1.312	0.75	0.468	0.375	0.375	0.187	0.5156	0.25 UNF-28	691	272	23
JFTS5/16	0.313	0.437	0.344	0.875	1.375	0.75	0.5	0.437	0.437	0.187	0.625	0.3125 UNF-24	952	419	37
JFTS3/8	0.375	0.5	0.406	1	1.625	0.937	0.687	0.562	0.5	0.25	0.7187	0.375 UNF-24	1315	612	59
JFTS7/16	0.4375	0.562	0.437	1.25	1.812	1.062	0.75	0.625	0.562	0.25	0.8125	0.4375 UNF-20	1632	793	82
JFTS1/2	0.5	0.625	0.5	1.312	2.125	1.187	0.875	0.75	0.625	0.25	0.937	0.5 UNF-20	2041	1020	132
JFTS5/8	0.625	0.75	0.562	1.5	2.5	1.5	1	0.875	0.75	0.312	1.125	0.625 UNF-18	2449	1270	191
JFTS3/4	0.75	0.875	0.687	1.75	2.875	1.75	1.125	1	0.875	0.312	1.312	0.75 UNF-16	3447	1859	286

Stainless steel 306 body with PTFE liner. Ball 440C heat-treated.

Left and right hand available.

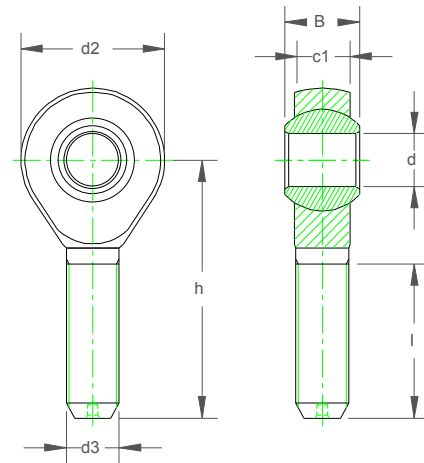

	Dimensions										Static Load (kgf)		Weight gr
	d	B	C1	d2	h	l1	Ball Dia	Thread	Radial	Axial			
JMTS3/16	0.19	0.312	0.25	0.625	1.25	0.75	0.4375	0.19 UNF-32	306	215	14		
JMTS1/4	0.25	0.375	0.281	0.75	1.562	1	0.5156	0.25 UNF-28	453	272	23		
JMTS5/16	0.3125	0.437	0.344	0.875	1.875	1.25	0.625	0.3125 UNF-24	771	408	37		
JMTS3/8	0.375	0.5	0.406	1	1.938	1.25	0.7187	0.375 UNF-24	1270	589	55		
JMTS7/16	0.4375	0.562	0.437	1.25	2.125	1.375	0.8125	0.4375 UNF-20	1610	748	78		
JMTS1/2	0.5	0.625	0.5	1.312	2.438	1.5	0.937	0.5 UNF-20	2041	1065	123		
JMTS5/8	0.625	0.75	0.562	1.5	2.625	1.625	1.125	0.625 UNF-18	2449	1270	186		
JMTS3/4	0.75	0.875	0.687	1.75	2.875	1.75	1.312	0.75 UNF-16	3458	1814	295		



Thrust Joints

Used in linear motion to absorb eccentricity when installed on the end of hydraulic and pneumatic cylinders.



**THRUST JOINTS
TJ(FJ)**

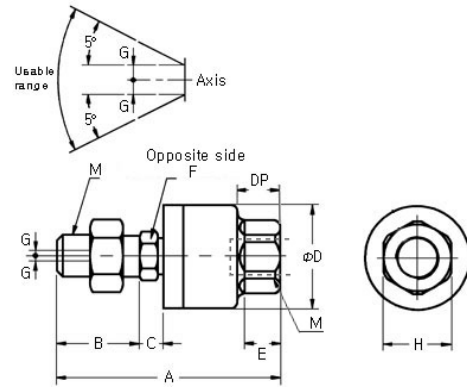

	Thread		Dimensions (mm)								Permissible Eccentricity	Tensile & Comp Strength	Cylinder Bore Diameter
	M	DP	A	B	C	D	E	F	H	Tilting Angle	G	Max Kgf	
TJ5	M5X.8	7	34.5	14	2	16	5	6	10	10	0.5	12	10,15
TJ6	M6X1	7	34.5	14	2	16	5	6	10	10	0.5	12	15
TJ8	M8X1.25	8	44	17.5	4.5	21	7	8	13	10	0.5	110	20
TJ10	M10X1.25	9	49.5	19.5	5	24	8	10	17	10	0.5	250	25,30
TJ12	M12X1.75	13	60	20	6	31	11	12	22	10	0.75	440	30,40
TJ14	M14X1.5	13	60	20	6	31	11	14	22	10	0.75	600	40
TJ16	M16X1.5	15	71.5	22	7.5	41	13.5	16	27	10	1	1100	50
TJ16-2	M16X2												
TJ18	M18X1.5	15	74.5	25	7.5	41	13.5	18	27	10	1	1100	50,63
TJ20	M20X1.5	18	90.5	30	9.5	50	16	20	32	10	1.25	1800	80
TJ20-2	M20X2.5												
TJ22	M22X1.5	18	89.5	29	9.5	50	16	22	32	10	1.25	1800	80
TJ24	M24X1.5	24	110	35	11.5	59.5	20	26	41	10	2	2800	100
TJ24-3	M24X3												
TJ26	M26X1.5	24	110	35	11.5	59.5	20	26	41	10	2	2800	100
TJ30	M30X1.5	38	152	45	14	79	22	30	46	10	2	5400	125,140
TJ30-2	M30X2												
TJ36	M36X1.5	42	178	55	16	96	24	36	55	10	3	7100	160

A



Spherical Planes

Standard

Steel on steel metric sealed. Ideal to fit control arms into custom fittings and housings.



GE

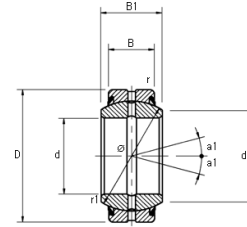

GE..ES-2RS

	Dimensions								Tilting Angle	Tilting Angle	Dynamic Load Rating	Static Load Rating	Mass
	d	D	B	B1	d1	Ball Dia	r1 min	r1					
GE10E	10	19	6	9	13	16	0.3	0.3	12		960	5760	12
GE12E	12	22	7	10	15	18	0.3	0.3	11		1260	7560	17
GE15ES-2RS	15	26	9	12	18.4	22	0.3	0.3		5	1980	11900	32
GE17ES-2RS	17	30	10	14	20.7	25	0.3	0.3		7	2500	15000	49
GE20ES-2RS	20	35	12	16	24.2	29	0.3	0.3		6	3480	20900	65
GE25ES-2RS	25	42	16	20	29.3	35.5	0.6	0.6		4	5680	34100	115
GE30ES-2RS	30	47	18	22	34.2	40.7	0.6	0.6		4	7330	44000	160
GE35ES-2RS	35	55	20	25	39.8	47	0.6	1		4	9400	56400	258
GE40ES-2RS	40	62	22	28	45	53	0.6	1		4	11700	70000	315
GE45ES-2RS	45	68	25	32	50.8	60	0.6	1		4	15000	90000	413
GE50ES-2RS	50	75	28	35	56	66	0.6	1		4	18500	111000	560
GE60ES-2RS	60	90	36	44	66.8	80	1	1	6	3	28800	173000	1100
GE70ES-2RS	70	105	40	49	77.9	92	1	1	6	4	36800	221000	1540
GE80ES-2RS	80	120	45	55	89.4	105	1	1	6	4	47300	284000	2290
GE90ES-2RS	90	130	50	60	98.1	115	1	1	5	3	57500	345000	2820

Other Types

SB
Wide High Load



JET
Teflon Liner



JS
Steel on Composite



JETS
Teflon Liner Stainless



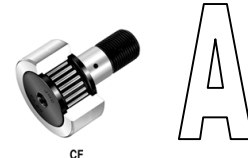

Track Rollers and Cam Followers

Standard Stud Type Track Roller

Crowned type CF_UUR compensates for parallelism errors.

Full complement of needle rollers CR_VUUR for higher loads

Other types available

- Cylindrical type CF_UU
- Imperial type CR_UU

Second figures for load and weights are for full complement.

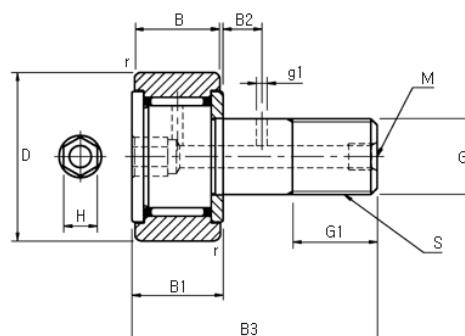

			Dimensions										Minimum Clamping	Dynamic Load Rating 10 ⁶ rev	Static Load Rating	Limiting Speed	Mass
Crowned Outer	Full Complement	Thread (GxS)	H	D	B	B1	B3	M	g1	G1	B2	r	Diameter	C(Kgf)	Co(Kgf)	RPM	gr.
CF5UUR	CF5VUUR	M5X.8	3	13	9	10	23			7.5		0.5	9.7	280/400	180/280	29000/15000	10.5/11
CF6UUR	CF6VUUR	M6X1	3	16	11	12	28			9		0.5	11	270/710	170/870	25000/12000	18.5/19
CF8UUR	CF8VUUR	M8X1.25	4	19	11	12	32			11		0.5	13	300/830	210/1140	20000/9000	28.5/29
CFA10UUR	CFA10VUUR	M10X1	4	22	12	13	36			13		1	15	410/970	320/1480	17000/7000	45/46
CFA10-1UUR	CFA10-1VUUR			26													60/61
CF10UUR	CF10VUUR	M10X1.25	4	22	12	13	36			13		1	15	410/970	320/1480	17000/7000	45/46
CF10-1UUR	CF10-1VUUR			26													60/61
CF12UUR	CF12VUUR	M12X1.5	6	30	14	15	40	M6X1	3	14	6	1.5	20	590/1370	450/2010	14000/6000	95/97
CF12-1UUR	CF12-1VUUR			32													105/107
CF16UUR	CF16VUUR	M16X1.5	6	35	18	19.5	52	M6X1	3	18	8	1.5	24	850/2110	760/3840	10000/4500	170/173
CF18UUR	CF18VUUR	M18X1.5	8	40	20	21.5	58	M6X1	3	20	10	1.5	26	1180/2580	1220/5240	8500/3500	250/255
CF20UUR	CF20VUUR	M20X1.5	8	52	24	25.5	66	M6X1	3	22	12	1.5	36	1630/3380	1690/6580	7000/3500	460/465
CF20-1UUR	CF20-1VUUR			47													385/390
CF24UUR	CF24VUUR	M24X1.5	8	62	29	30.5	80	M6X1	3	25	12	1.5	40	2160/4750	2210/9390	6500/3000	815/820
CF24-1UUR	CF24-1VUUR			72													1140/1140
CF30UUR	CF30VUUR	M30X1.5	8	80	35	37	100	M6X1	3	32	15	2	46	2830/6900	3700/14700	5000/2000	1870/1870
CF30-1UUR	CF30-1VUUR			85													2030/2030
CF30-2UUR	CF30-2VUUR			90													2220/2220

Eccentric Ring Stud Type Track Roller

Eccentric ring for adjustment of radial clearance. Compensates for precision errors and allows for backlash adjustment.

Adjustment can be made by turning shaft by hex key in bearing face.

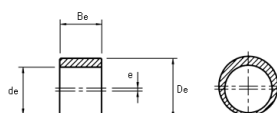

o	Type	de (R7)	De (h9)	Be	e
M6	CF6	6 ^{-0.011} _{-0.023}	9 ⁰ _{-0.036}	7 ^{0.1} ₀	0.5
M8	CF8	8 ^{-0.013} _{-0.028}	11 ⁰ _{-0.043}	9 ^{0.1} ₀	0.5
M10	CF10	10 ^{-0.013} _{-0.028}	13 ⁰ _{-0.043}	10 ^{0.1} ₀	0.5
M12	CF12	12 ^{-0.016} _{-0.034}	15 ⁰ _{-0.043}	11 ^{0.1} ₀	0.5
M16	CF16	16 ^{-0.016} _{-0.034}	20 ⁰ _{-0.052}	14 ^{0.1} ₀	1
M18	CF18	18 ^{-0.016} _{-0.034}	22 ⁰ _{-0.052}	16 ^{0.1} ₀	1
M20	CF20	20 ^{-0.02} _{-0.041}	24 ⁰ _{-0.052}	18 ^{0.1} ₀	1
M24	CF24	24 ^{-0.02} _{-0.041}	28 ⁰ _{-0.052}	22 ^{0.1} ₀	1
M30	CF30	30 ^{-0.02} _{-0.041}	35 ⁰ _{-0.062}	29 ^{0.1} ₀	1.5

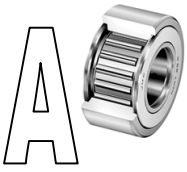

Other Cam Follower types

CR
Imperial dimensions



NUKR
Double row high load

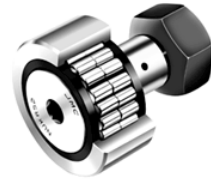

CFH
Solid shaft eccentric cam



CFO
With oil hole for forced lubrication



Yoke Type Track Rollers

NART
Standard type



NART V
Full Complement



NUTR
Cage type double row

Two outer sizes available for each bore size.

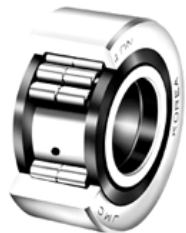

NAST
Separable Inner and Outer Ring

NAST ZZ
Separable Inner and Outer Cage and retaining washer



RNAST
Separable outer ring