

Precision Gear heads

Complete your position system with a precision planetary gearhead from Apex. These are high quality extremely accurate gear heads used to increase a servomotors torque output or inertia capacity. Use of a planetary gear mechanism allows an extremely small physical size. Precision NC machining and robotics used in the manufacturing process allow Apex to produce a highly efficient and quiet gear head. Apex are the largest precision gear head manufacture in the world and gear heads to suit most motors can be delivered in 7 days.

Ratios range from 3 to 100 in 1 or 2 stages with a range of frame sizes with up to 2000Nm nominal output torque. The precision AB series offers backlash down to 1 arc minutes or 0.016 of a degree. Frames are IP65 or IP64 as standard and lubricated for life. All types mount directly onto the servomotor with an interface flange to suit the motor and have a built in clamp coupling for the motor shaft. Apex have a huge range of interface plates available from stock to suit nearly every servo motor.

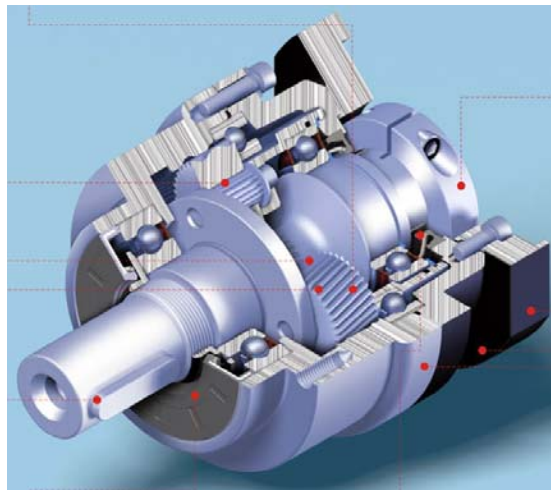

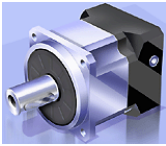

AB Series	Premium Helical	AB	Inline	Ratios: 1-100 Backlash: 1-7arcmin Output: 2-2000Nm Stainless body, Anodised adaptor, IP65, lubricated for life.
		ABR	Right Angle	
AE Series	Economy Helical	AE	Inline	Ratios: 1-100 Backlash: 8-12arcmin Output: 2-2000Nm Stainless body, Anodised adaptor, IP65, lubricated for life.
		AER	Right Angle	
P Series	Low cost spur gear	PE, PG, PN, PB	Inline Various Dimensional standards	Ratios: 1-100 Backlash: 8-10arcmin Output: 9-400Nm Electro Coated, Anodised adaptor, IP64, lubricated for life



APEX DYNAMICS, INC.

Other versions available

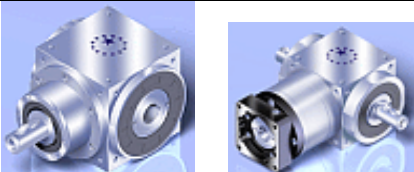
	AD and ADR flange drive
	AL and ALR pulley drive
	AN and ANR NEMA mount
	AT series spiral bevel in a wide range of styles

Other manufacturers

