

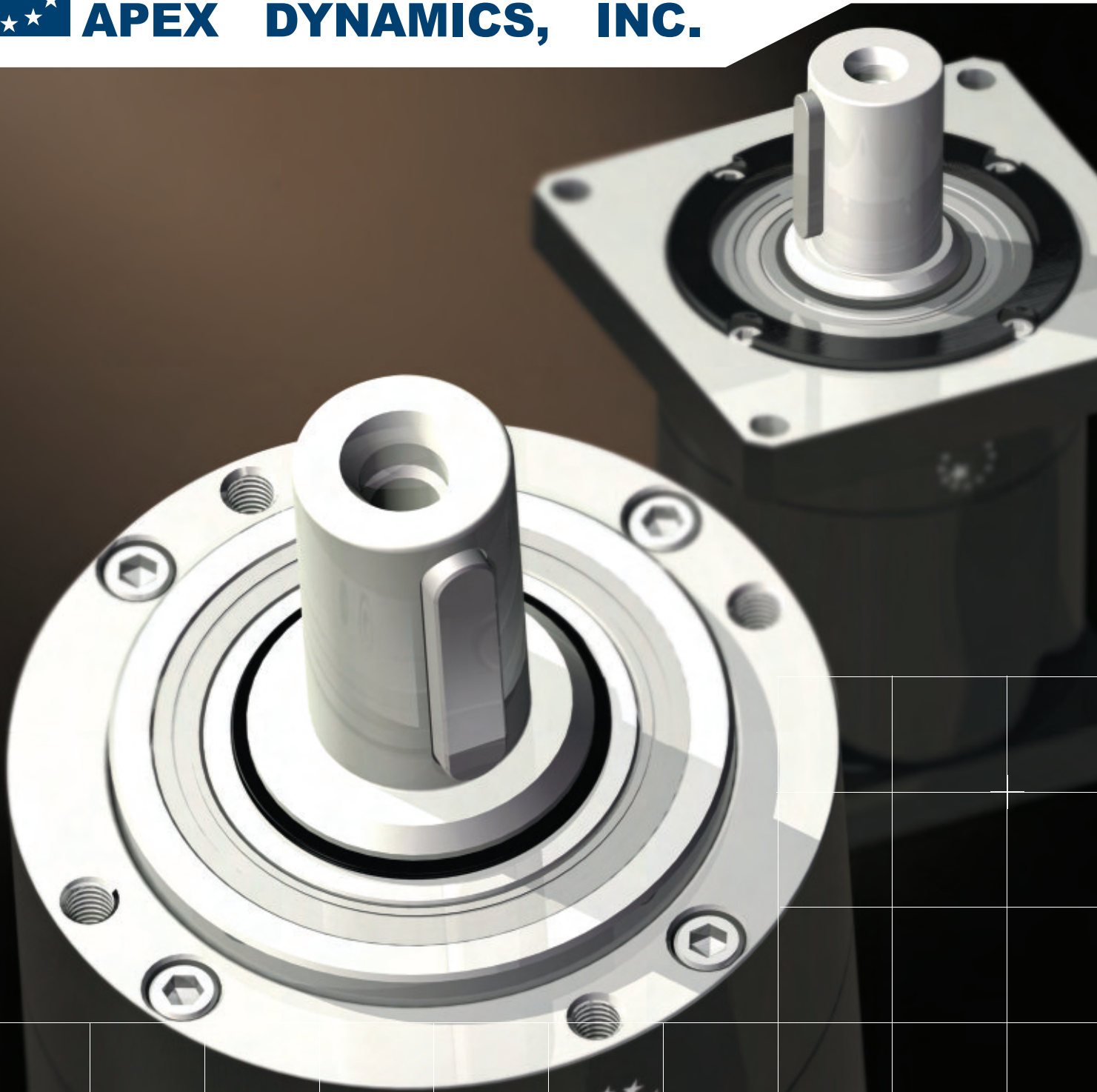

APEX DYNAMICS, INC.



PE/PG/PN/PB
SERIES

Planetary Gearboxes

PE/PG/PN/PB Series

Characteristic Highlights



One piece planet carrier and planet gearing is supported on both sides. Provide maximum radial load capacity and increase system reliability and stiffness.

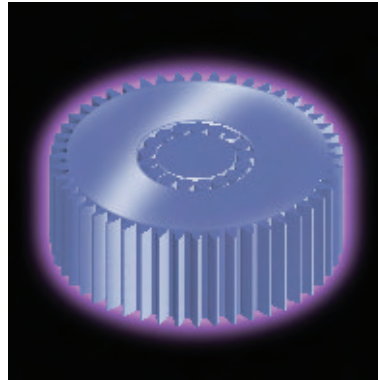

Equipped with *solid uncaged needle roller bearings*, provides maximum contact points to increase stiffness and generates high output torque. *Our in-house plasma nitriding* heat treatment process maintains the tooth surface hardness at **900Hv** for superior wear-resistance and a core hardness at **30 HRC** for toughness.

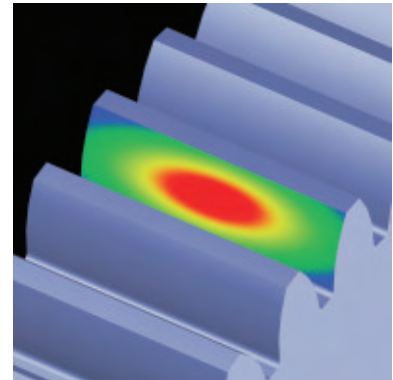

A high setting gear performance is achieved by using our *HeliTop technology*. This *eases off the tooth profile and crowns the lead of each tooth*. This optimizes the gear mesh alignment and overlap to achieve maximum tooth surface contact.

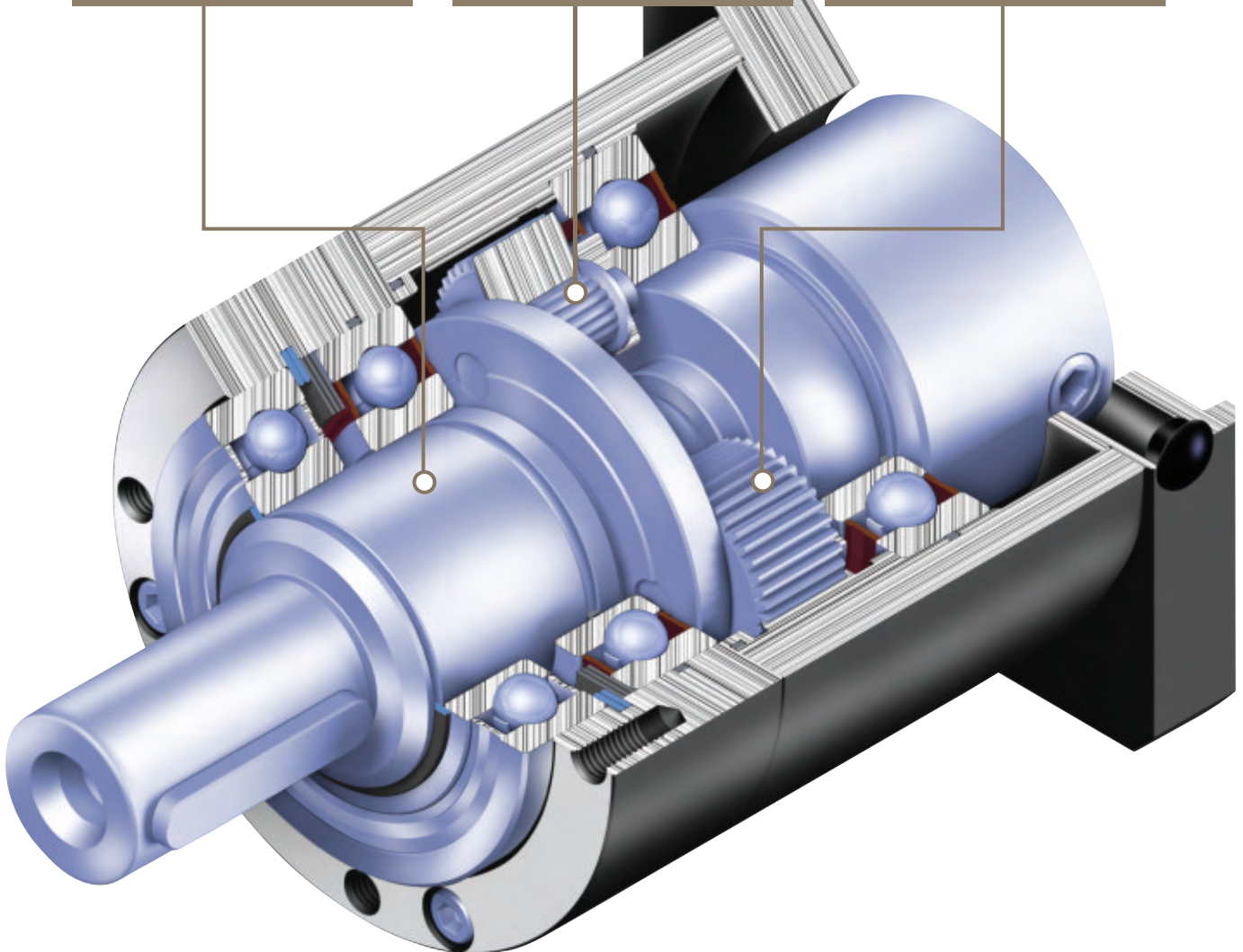

Permitted Radial and Axial Loads on Output Shaft of the Gearbox

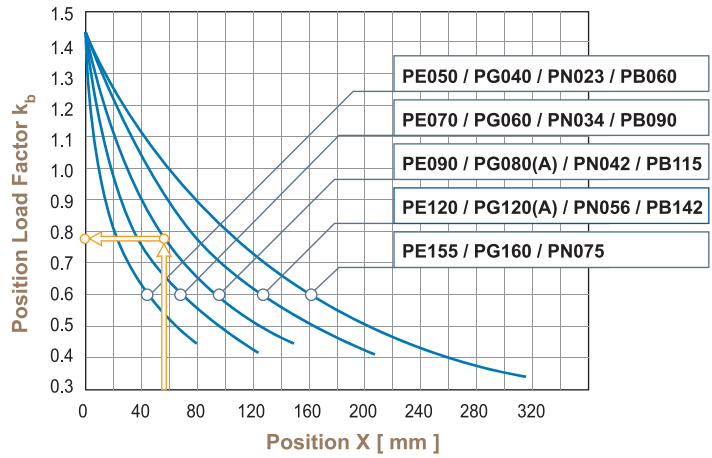
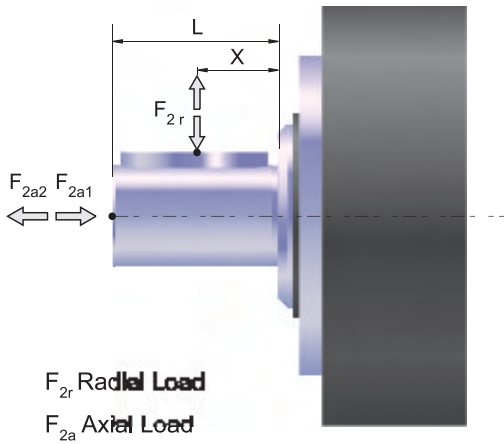

The permitted radial and axial loads on output shaft of the gearbox depend on the design of the gearbox supporting bearings.

If radial force F_{2r} is not exerted on the center of the output shaft $X < 1/2xL$ or $X > 1/2xL$. The permitted radial and axial loads can be calculated by the position load factor K_b on the above diagram.

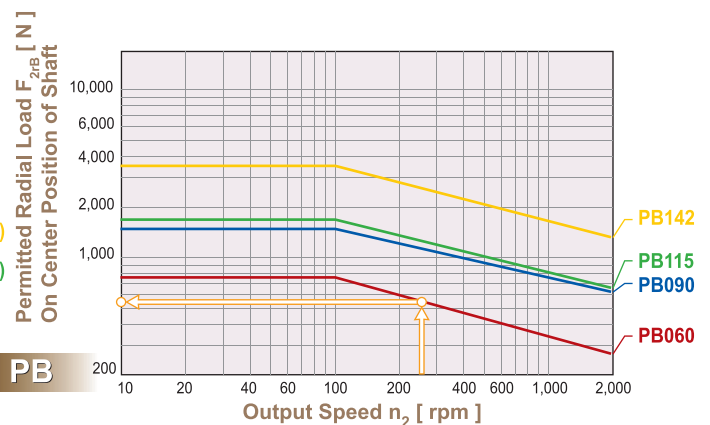
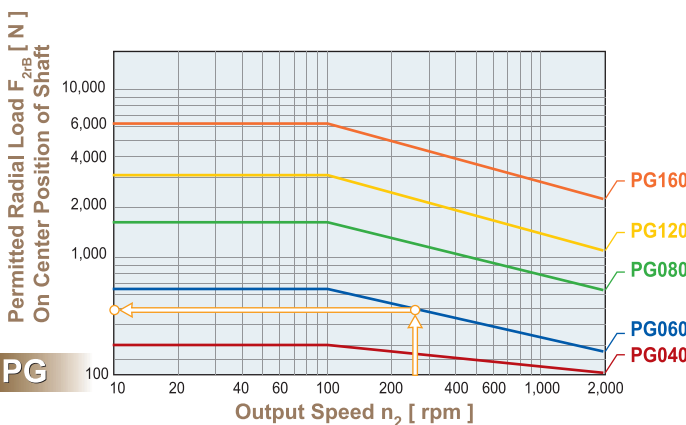
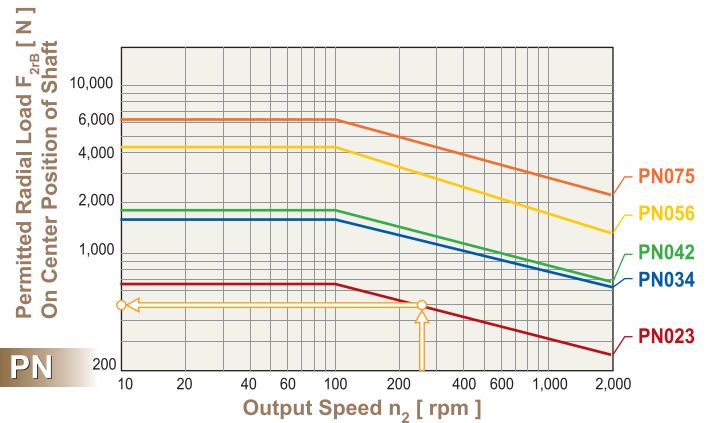
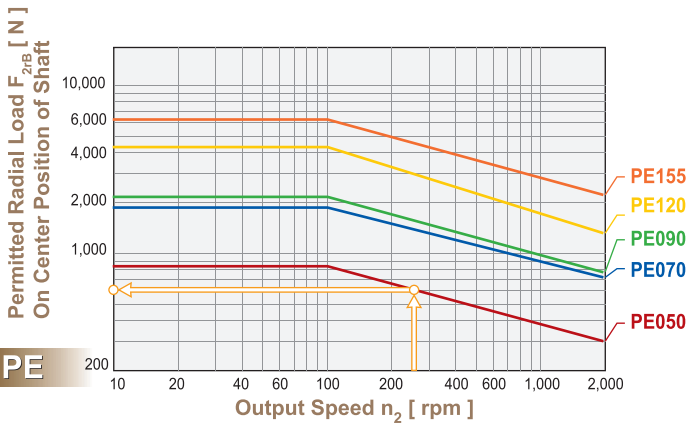

If radial force F_{2r} exert on the center of the output shaft $X=1/2xL$. Under various operating condition the lifetime is over 20,000* hours. The permitted radial load is given on the above diagram.

*Continuous operation reduces service life by 50%

PE Series Specifications

Gearbox Performance

Model No.	Stages	Ratio ¹	PE050	PE070	PE090	PE120	PE155	
Nominal Output Torque T_{2N}	1	3	14	39	104	215	423	
		4	12	31	85	176	364	
		5	14	39	104	215	423	
		7	12	33	91	195	358	
		10	9	26	65	150	293	
	2	15	14	39	104	215	423	
		16	12	31	85	176	364	
		20	12	31	85	176	364	
		25	14	39	104	215	423	
		30	14	39	104	215	423	
		35	12	33	91	195	358	
		40	12	31	95	176	364	
		50	14	39	104	215	423	
		70	12	33	91	195	358	
		100	9	26	65	150	293	
Emergency Stop Torque T_{2NOT} ²	Nm	1,2	3 times of Nominal Output Torque					
Nominal Input Speed n_{1N}	rpm	1,2	3~100	4,500	4,000	3,600	3,000	2,500
Max. Input Speed n_{1B}	rpm	1,2	3~100	8,000	6,000	6,000	4,800	3,600
Backlash*	arcmin	1	3~10	≤ 8	≤ 8	≤ 6	≤ 6	≤ 6
		2	15~100	≤ 10	≤ 10	≤ 8	≤ 8	≤ 8
Torsional Rigidity	Nm/arcmin	1,2	3~100	2	4.4	13.5	35.6	64
Max. Radial Load F_{2rB} ³	N	1,2	3~100	820	1,910	2,060	4,160	6,450
Max. Axial Load F_{2aB} ³	N	1,2	3~100	410	955	1,030	2,080	3,225
Service Life	hr	1,2	3~100	20,000*				
Efficiency η	%	1	3~10	≥ 97%				
		2	15~100	≥ 94%				
Weight	kg	1	3~10	0.8	1.9	3.8	8.9	18.0
		2	15~100	1.1	2.7	5.2	12.2	24.6
Operating Temp	°C	1,2	3~100	0°C~+90°C				
Lubrication		1,2	3~100	CASTROL LMX Grease				
Degree of Gearbox Protection		1,2	3~100	IP64				
Mounting Position		1,2	3~100	all directions				
Noise Level ($n_1=3,000$ rpm)	dB	1,2	3~100	≤ 68	≤ 70	≤ 72	≤ 74	≤ 75

Gearbox Inertia

Model No.	Stages	Ratio ¹	PE050	PE070	PE090	PE120	PE155
Mass Moments of Inertia J_1	1	3	0.16	0.63	3.48	12.84	36.72
		4	0.16	0.60	3.31	12.22	34.63
		5	0.16	0.59	3.28	12.10	34.24
		7	0.16	0.59	3.27	12.05	34.07
		10	0.16	0.59	3.26	12.03	34.02
	2	15	0.16	0.59	3.28	12.10	34.24
		16	0.16	0.60	3.31	12.22	34.63
		20	0.16	0.59	3.28	12.10	34.24
		25	0.16	0.59	3.28	12.10	34.24
		30	0.16	0.59	3.26	12.03	34.02
		35	0.16	0.59	3.28	12.10	34.24
		40	0.16	0.59	3.26	12.03	34.02
		50	0.16	0.59	3.26	12.03	34.02
		70	0.16	0.59	3.26	12.03	34.02
		100	0.16	0.59	3.26	12.03	34.02

1. Ratio ($i=N_{in}/N_{out}$)

2. $T_{2B} = 60\%$ of T_{2NOT}

3. Applied to the output shaft center @ 100 rpm

*Service life for cycloid duty (S5) is 20,000 hrs, for continuous duty (S1) is reduced by 50%.

*Backlash is measured at 2% of Nominal Output Torque T_{2N}

PE Series Dimension

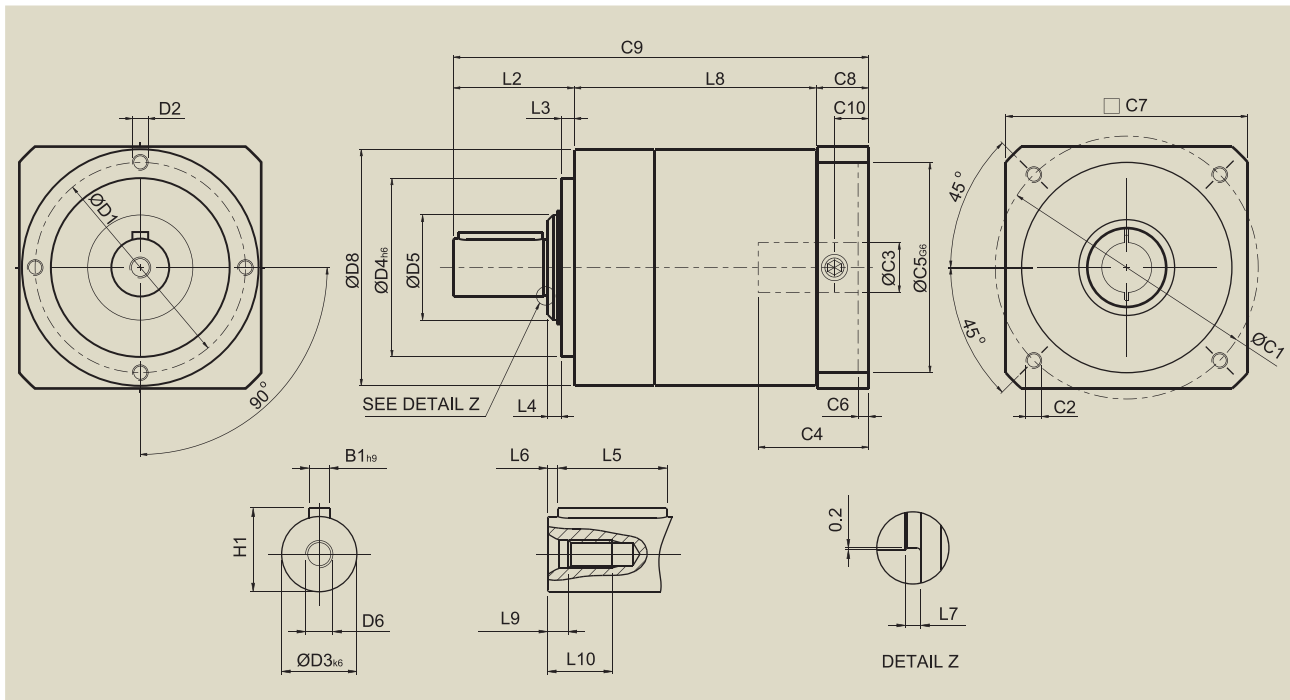

[unit: mm]

Dimension	PE050	PE070	PE090	PE120	PE155
D1	44	62	80	108	140
D2	M4X9	M5X10	M6X12	M8X15	M10X18
D3 _{k6}	12	16	22	32	40
D4 _{h6}	35	52	68	90	120
D5	17	25	40	50	65
D6	M4X0.7P	M5X0.8P	M8X1.25P	M12X1.75P	M16X2P
D8	50	70	90	120	155
L2	24.5	36	46	70	97
L3	4	5	5	6	8
L4	2.5	3	5	6	7
L5	14	25	32	50	70
L6	2	2	2	4	6
L7	1	1	1.5	2	2
L8	1-stage	55	77	92	145
	2-stage	79.5	110	131.5	205.5
L9	4.5	4.8	7.2	10	12
L10	10	12.5	19	28	36
C1 ⁴	46	70	100	130	165
C2 ⁴	M4X0.7P	M5X0.8P	M6X1P	M8X1.25P	M10X1.5P
C3 ⁴	≤ 12	≤ 16	≤ 24	≤ 32	≤ 38
C4 ⁴	30	34	40	50	60
C5 ⁴ _{G6}	30	50	80	110	130
C6 ⁴	3.5	8	4	5	6
C7 ⁴	52	72	92	122	157
C8 ⁴	21.5	21.5	20	24	31
C9 ⁴	1-stage	101	134.5	158	273
	2-stage	125.5	167.5	197.5	333.5
C10 ⁴	14.5	15.5	13	16	21
B1 _{h9}	4	5	6	10	12
H1	13.5	18	24.5	35	43

4. C1~C10 are motor specific dimensions (metric std shown). Refer to Apexdyna.com and Design Tool to view your specific motor mounting system.

PG(PGA) Series Specifications

Gearbox Performance

Model No.	Stages	Ratio ¹	PG040	PG060	PG080	PG080A	PG120	PG120A	PG160	
Nominal Output Torque T_{2N}	1	3	14	39	104		215		423	
		4	12	31	85		176		364	
		5	14	39	104		215		423	
		7	12	33	91		195		358	
		10	9	26	65		150		293	
	2	15	14	39	104		215		423	
		16	12	31	85		176		364	
		20	12	31	85		176		364	
		25	14	39	104		215		423	
		30	14	39	104		215		423	
		35	12	33	91		195		358	
		40	12	31	85		176		364	
		50	14	39	104		215		423	
		70	12	33	91		195		358	
	100	9	26	65		150		293		
	Emergency Stop Torque T_{2NOT} ²	Nm	1,2	3~100 3 times of Nominal Output Torque						
	Nominal Input Speed n_{1N}	rpm	1,2	3~100	4500	4000	3600		3600	2500
	Max. Input Speed n_{1B}	rpm	1,2	3~100	8000	6000	6000		4800	3600
Backlash*	arcmin	1	3~10	≤ 8	≤ 8	≤ 6		≤ 6		
		2	15~100	≤ 10	≤ 10	≤ 8		≤ 8		
Torsional Rigidity	Nm/arcmin	1,2	3~100	0.8	2.2	7.2		14.5		65.5
Max. Radial Load F_{2rB} ³	N	1,2	3~100	300	680	1750		3080		6520
Max. Axial Load F_{2aB} ³	N	1,2	3~100	150	340	875		1540		3260
Service Life	hr	1,2	3~100	20,000*						
Efficiency η	%	1	3~10	≥ 97%						
		2	15~100	≥ 94%						
Weight	kg	1	3~10	0.7	1.7	3.6	3.6	8.1	8.2	18.2
		2	15~100	1.0	2.4	5.0	5.0	11.3	11.4	24.9
Operating Temp	°C	1,2	3~100	0°C~+90°C						
Lubrication		1,2	3~100	CASTROL LMX Grease						
Degree of Gearbox Protection		1,2	3~100	IP64				IP64		
Mounting Position		1,2	3~100	all directions						
Noise Level ($n_1=3,000\text{rpm}$)	dB	1,2	3~100	≤ 68	≤ 70	≤ 72		≤ 74		

Gearbox Inertia

Model No.	Stages	Ratio ¹	PG040	PG060	PG080	PG080A	PG120	PG120A	PG160
Mass Moments of Inertia J_1	1	3	0.16	0.63	3.48		12.84		36.72
		4	0.16	0.60	3.31		12.22		34.63
		5	0.16	0.59	3.28		12.10		34.24
		7	0.16	0.59	3.27		12.05		34.07
		10	0.16	0.59	3.26		12.03		34.02
	2	15	0.16	0.59	3.28		12.10		34.24
		16	0.16	0.60	3.31		12.22		34.63
		20	0.16	0.59	3.28		12.10		34.24
		25	0.16	0.59	3.28		12.10		34.24
		30	0.16	0.59	3.26		12.03		34.02
		35	0.16	0.59	3.28		12.10		34.24
		40	0.16	0.59	3.26		12.03		34.02
		50	0.16	0.59	3.26		12.03		34.02
		70	0.16	0.59	3.26		12.03		34.02
		100	0.16	0.59	3.26		12.03		34.02

1. Ratio ($i=N_{in}/N_{out}$)

2. $T_{2B} = 60\%$ of T_{2NOT}

3. Applied to the output shaft center @ 100 rpm

*Service life for cycloid duty (S5) is 20,000 hrs, for continuous duty (S1) is reduced by 50%.

*Backlash is measured at 2% of Nominal Output Torque T_{2N}

PG(PGA) Series Dimension

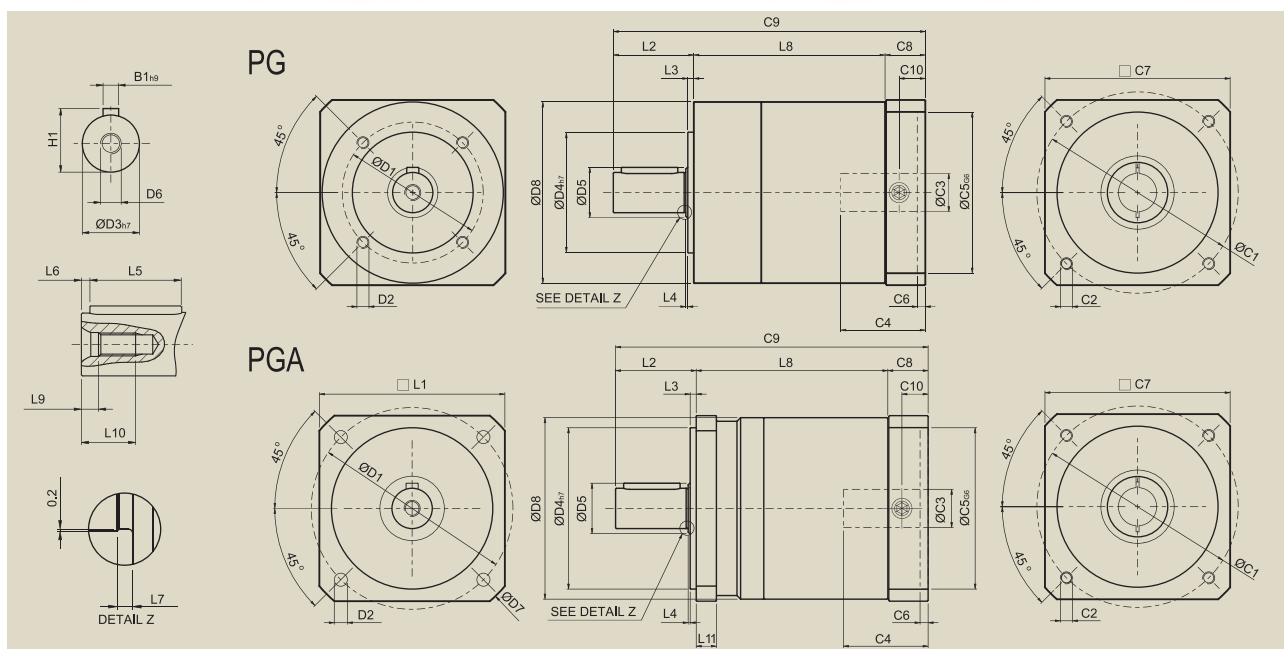

[unit: mm]

Dimension	PG040	PG060	PG080	PG080A	PG120	PG120A	PG160
D1	34	52	70	100	100	130	145
D2	M4X9	M5X10	M6X12	6.5	M10X18	8.5	M12X22
D3 _{h7}	10	14	20	25	25	40	40
D4 _{h7}	26	40	60	80	80	110	130
D5	12	17	25	35	65	65	65
D6	M3X0.5P	M5X0.8P	M6X1P	M10X1.5P	M16X2P	M16X2P	M16X2P
D7	-	-	-	120	-	167.5	-
D8	50	70	90	120	160	160	160
L1	-	-	-	92	-	124	-
L2	26	35	40	55	87	87	87
L3	2	3	3	4	5	5	5
L4	1	2	1	1	2	2	2
L5	18	25	28	40	65	65	65
L6	2.5	2.5	4	5	8	8	8
L7	1	1	1	1.5	2	2	2
L8	1-stage	50	68.5	95	125	153	153
	2-stage	74.5	101.5	134.5	178	213.5	213.5
L9	2.2	4.8	5	6.5	12	12	12
L10	9.5	12.5	16.5	23	36	36	36
L11	-	-	-	10	-	15	-
C1 ⁴	46	70	100	130	165	165	165
C2 ⁴	M4X0.7P	M5X0.8P	M6X1P	M8X1.25P	M10X1.5P	M10X1.5P	M10X1.5P
C3 ⁴	≤ 12	≤ 16	≤ 24	≤ 32	≤ 38	≤ 38	≤ 38
C4 ⁴	30	34	40	50	60	60	60
C5 ¹ _{G6}	30	50	80	110	130	130	130
C6 ⁴	3.5	8	4	5	6	6	6
C7 ⁴	52	72	92	122	157	157	157
C8 ⁴	21.5	21.5	20	24	31	31	31
C9 ⁴	1-stage	97.5	125	155	204	271	271
	2-stage	122	158	194.5	257	331.5	331.5
C10 ⁴	14.5	15.5	13	16	21	21	21
B1 _{h9}	3	5	6	8	12	12	12
H1	11.2	16	22.5	28	43	43	43

4. C1-C10 are motor specific dimensions (metric std shown). Refer to Apexdyna.com and Design Tool to view your specific motor mounting system.

PN Series Specifications

Gearbox Performance

Model No.	Stages	Ratio ¹	PN023	PN034	PN042	PN056	PN075	
Nominal Output Torque T_{2N}	1	3	14	39	104	215	423	
		4	12	31	85	176	364	
		5	14	39	104	215	423	
		7	12	33	91	195	358	
		10	9	26	65	150	293	
	2	15	14	39	104	215	423	
		16	12	31	85	176	364	
		20	12	31	85	176	364	
		25	14	39	104	215	423	
		30	14	39	104	215	423	
		35	12	33	91	195	358	
		40	12	31	85	176	364	
		50	14	39	104	215	423	
		70	12	33	91	195	358	
		100	9	26	65	150	293	
		Emergency Stop Torque T_{2NOT} ²	Nm	1,2	3 times of Nominal Output Torque			
Nominal Input Speed n_{1N}	rpm	1,2	3~100	4,500	4,000	3,600	3,000	2,500
Max. Input Speed n_{1B}	rpm	1,2	3~100	8,000	6,000	6,000	4,800	3,600
Backlash*	arcmin	1	3~10	≤ 8	≤ 8	≤ 6	≤ 6	≤ 6
		2	15~100	≤ 10	≤ 10	≤ 8	≤ 8	≤ 8
Torsional Rigidity	Nm/arcmin	1,2	3~100	1.6	6.4	17.5	62.8	143.5
Max. Radial Load F_{2rB} ³	N	1,2	3~100	680	1,770	1,830	4,140	6,440
Max. Axial Load F_{2aB} ³	N	1,2	3~100	340	885	915	2,070	3,220
Service Life	hr	1,2	3~100	20,000*				
Efficiency η	%	1	3~10	≥ 97%				
		2	15~100	≥ 94%				
Weight	kg	1	3~10	0.8	2.3	4.6	9.7	19.7
		2	15~100	1.1	3.0	6.0	13.0	26.3
Operating Temp	°C	1,2	3~100	0°C~+90°C				
Lubrication		1,2	3~100	CASTROL LMX Grease				
Degree of Gearbox Protection		1,2	3~100	IP64				
Mounting Position		1,2	3~100	all directions				
Noise Level ($n_1=3,000\text{rpm}$)	dB	1,2	3~100	≤ 68	≤ 70	≤ 72	≤ 74	≤ 75

Gearbox Inertia

Model No.	Stages	Ratio ¹	PN023	PN034	PN042	PN056	PN075
Mass Moments of Inertia J_1	1	3	0.16	0.63	3.48	12.84	36.72
		4	0.16	0.60	3.31	12.22	34.63
		5	0.16	0.59	3.28	12.10	34.24
		7	0.16	0.59	3.27	12.05	34.07
		10	0.16	0.59	3.26	12.03	34.02
	2	15	0.16	0.59	3.28	12.10	34.24
		16	0.16	0.60	3.31	12.22	34.63
		20	0.16	0.59	3.28	12.10	34.24
		25	0.16	0.59	3.28	12.10	34.24
		30	0.16	0.59	3.26	12.03	34.02
		35	0.16	0.59	3.28	12.10	34.24
		40	0.16	0.59	3.26	12.03	34.02
		50	0.16	0.59	3.26	12.03	34.02
		70	0.16	0.59	3.26	12.03	34.02
		100	0.16	0.59	3.26	12.03	34.02

1. Ratio ($i=N_{in}/N_{out}$)

2. $T_{2B} = 60\%$ of T_{2NOT}

3. Applied to the output shaft center @ 100 rpm

*Service life for cycloid duty (S5) is 20,000 hrs, for continuous duty (S1) is reduced by 50%.

*Backlash is measured at 2% of Nominal Output Torque T_{2N}

PN Series Dimension

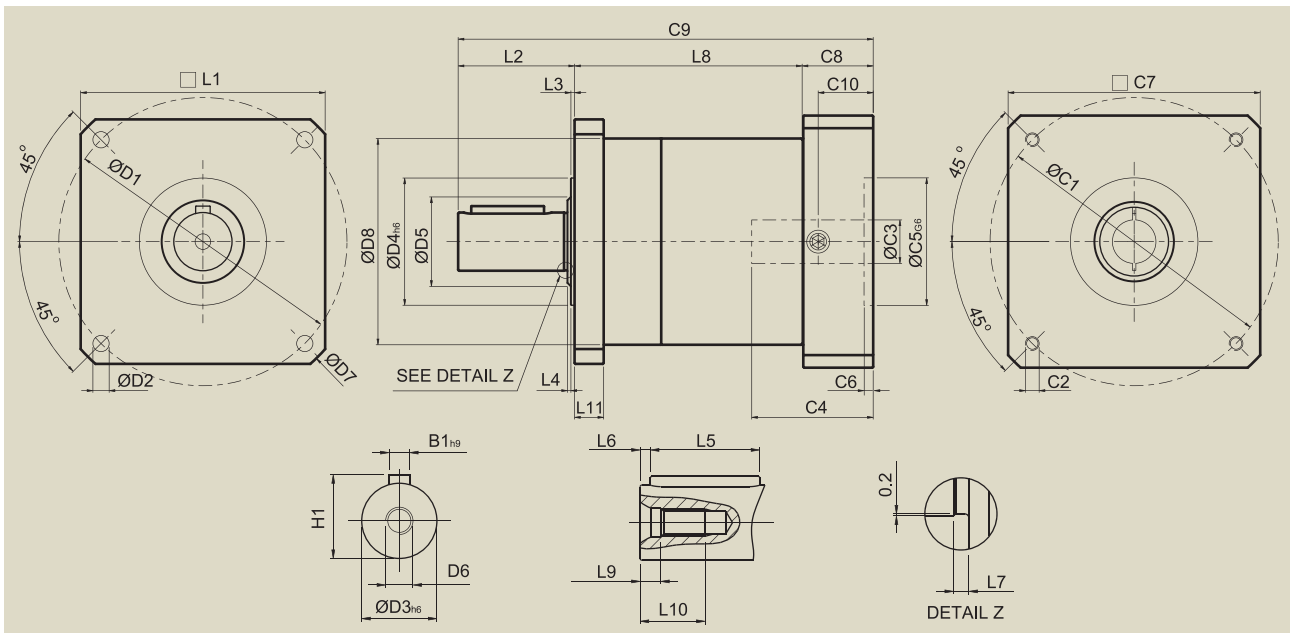

[unit: mm(inch)]

Dimension	PN023	PN034	PN042	PN056	PN075
D1	66.675(2.625)	98.425(3.875)	125.73(4.950)	177.8(7.0)	215.011(8.465)
D2	5.2(0.205)	5.6(0.220)	7.1(0.280)	10.4(0.409)	14.2(0.559)
D3 _{h6}	12.7(0.5)	19.05(0.750)	25.4(1.0)	38.1(1.5)	50.8(2.0)
D4 _{h6}	38.1(1.5)	73.025(2.875)	55.5(2.185)	114.3(4.5)	152.4(6.0)
D5	17	25	40	50	65
D6	M4X0.7P	M5X0.8P	M8X1.25P	M12X1.75P	M16X2P
D7	75	107.5	142	198	260
D8	50	70	90	120	155
L1	57.15(2.250)	82.55(3.250)	106.68(4.2)	146.05(5.750)	190(7.480)
L2	31.75	38.1	50.8	63.5	88.9
L3	1.6(0.063)	1.6(0.063)	1.6(0.063)	3.2(0.126)	4.75(0.187)
L4	1	1.5	1.5	2	2
L5	19.05(0.750)	25.4(1.0)	31.75(1.250)	38.1(1.5)	63.5(2.5)
L6	3.788(0.149)	3.8(0.150)	5.715(0.225)	8.563(0.337)	8.563(0.337)
L7	1	1	1.5	2	2
L8	1-stage	58.9	82	99.3	133.7
	2-stage	83.4	115	138.8	186.7
L9	4.5	4.8	7.2	10	12
L10	10	12.5	19	28	36
L11	6.4	7.9	12.7	19.05	22.2
C1 ⁴	66.675(2.625)	98.425(3.875)	125.73(4.950)	149.225(5.875)	165
C2 ⁴	M4X0.7P	M5X0.8P	M6X1P	11 Thru	M10X1.5P
C3 ⁴	≤ 12	≤ 16	≤ 24	≤ 32	≤ 38
C4 ⁴	32(1.260)	40(1.575)	51(2.008)	55(2.165)	60
C5 ⁴ _{G6}	38.15(1.502)	73.08(2.877)	55.65(2.191)	114.3(4.5)	130
C6 ⁴	3.5(0.138)	4(0.157)	4(0.157)	4(0.157)	6
C7 ⁴	55(2.165)	85(3.346)	110(4.331)	130(5.118)	157
C8 ⁴	23.5(0.925)	27.5(1.083)	31(1.220)	29(1.142)	31
C9 ⁴	1-stage	114.15(4.494)	147.6(5.811)	181.1(7.130)	226.2(8.905)
	2-stage	138.65(5.459)	180.6(7.110)	220.6(8.685)	279.2(10.992)
C10 ⁴	16.5(0.650)	21.5(0.846)	24(0.945)	21(0.827)	21
B1 _{h9}	3.175(0.125)	4.763(0.188)	6.35(0.250)	9.525(0.375)	9.525(0.375)
H1	14.125(0.556)	21.163(0.833)	28.2(1.110)	42.275(1.664)	55.125(2.170)

4. C1-C10 are NEMA motor specific dimensions (except for PN075). Refer to Apexdyna.com and Design Tool to view your specific motor mounting system.

PB Series Specifications

Gearbox Performance

Model No.	Stages	Ratio ¹	PB060	PB090	PB115	PB142		
Nominal Output Torque T_{2N}	1	3	14	39	104	215		
		4	12	31	85	176		
		5	14	39	104	215		
		7	12	33	91	195		
		10	9	26	65	150		
	2	15	14	39	104	215		
		16	12	31	85	176		
		20	12	31	85	176		
		25	14	39	104	215		
		30	14	39	104	215		
		35	12	33	91	195		
		40	12	31	85	176		
		50	14	39	104	215		
		70	12	33	91	195		
	100	9	26	65	150			
	Emergency Stop Torque T_{2NOT} ²	Nm	1,2	3~100	3 times of Nominal Output Torque			
	Nominal Input Speed n_{1N}	rpm	1,2	3~100	4,500	4,000	3,600	3,000
	Max. Input Speed n_{1B}	rpm	1,2	3~100	8,000	6,000	6,000	4,800
Backlash*	arcmin	1	3~10	≤ 8	≤ 8	≤ 6	≤ 6	
		2	15~100	≤ 10	≤ 10	≤ 8	≤ 8	
Torsional Rigidity	Nm/arcmin	1,2	3~100	3.7	7.2	15.1	60.5	
Max. Radial Load F_{2rB} ³	N	1,2	3~100	770	1,750	1,890	3,720	
Max. Axial Load F_{2aB} ³	N	1,2	3~100	385	875	945	1,860	
Service Life	hr	1,2	3~100	20,000*				
Efficiency η	%	1	3~10	≥ 97%				
		2	15~100	≥ 94%				
Weight	kg	1	3~10	0.9	2.2	4.3	10.0	
		2	15~100	1.2	3.0	5.7	13.3	
Operating Temp	°C	1,2	3~100	0°C~+90°C				
Lubrication		1,2	3~100	CASTROL LMX Grease				
Degree of Gearbox Protection		1,2	3~100	IP64				
Mounting Position		1,2	3~100	all directions				
Noise Level ($n_1=3,000$ rpm)	dB	1,2	3~100	≤ 68	≤ 70	≤ 72	≤ 74	

Gearbox Inertia

Model No.	Stages	Ratio ¹	PB060	PB090	PB115	PB142
Mass Moments of Inertia J_1	1	3	0.16	0.63	3.48	12.84
		4	0.16	0.60	3.31	12.22
		5	0.16	0.59	3.28	12.10
		7	0.16	0.59	3.27	12.05
		10	0.16	0.59	3.26	12.03
	2	15	0.16	0.59	3.28	12.10
		16	0.16	0.60	3.31	12.22
		20	0.16	0.59	3.28	12.10
		25	0.16	0.59	3.28	12.10
		30	0.16	0.59	3.26	12.03
		35	0.16	0.59	3.28	12.10
		40	0.16	0.59	3.26	12.03
		50	0.16	0.59	3.26	12.03
		70	0.16	0.59	3.26	12.03
	100	0.16	0.59	3.26	12.03	

1. Ratio ($i=N_{in}/N_{out}$)

2. $T_{2B} = 60\%$ of T_{2NOT}

3. Applied to the output shaft center @ 100 rpm

*Service life for cycloid duty (S5) is 20,000 hrs, for continuous duty (S1) is reduced by 50%.

*Backlash is measured at 2% of Nominal Output Torque T_{2N}

PB Series Dimension

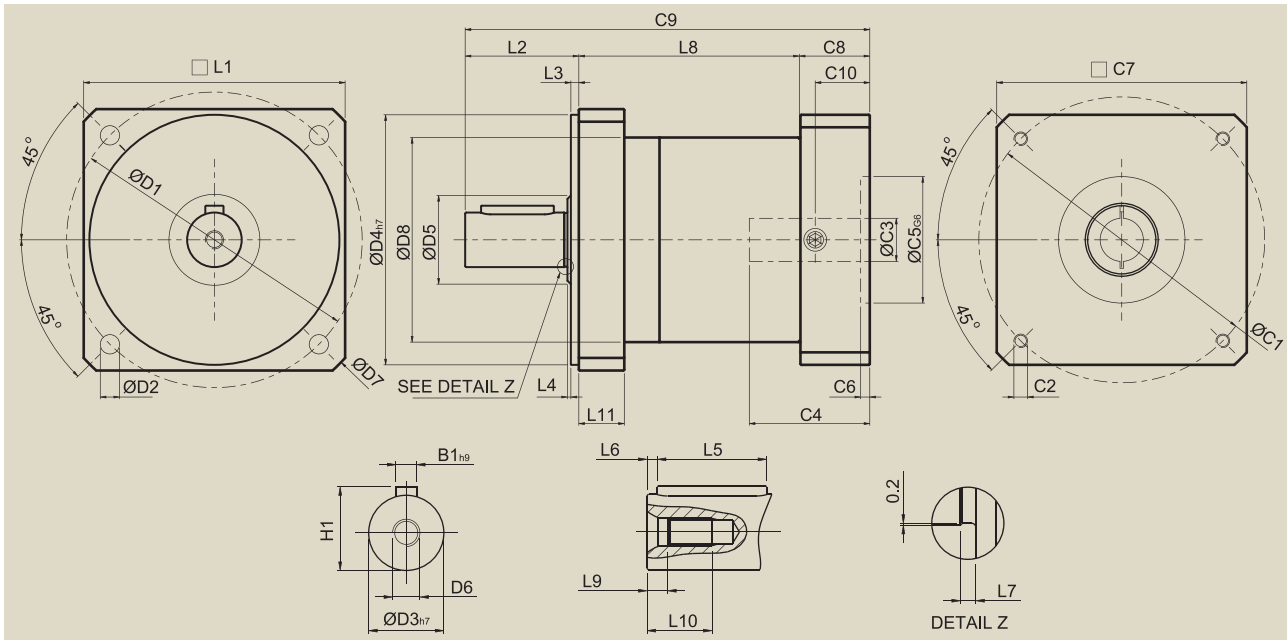

[unit: mm]

Dimension	PB060	PB090	PB115	PB142
D1	70	100	130	165
D2	5.5	6.5	9	11
D3 ^{h7}	16	20	24	40
D4 ^{h7}	50	80	110	130
D5	17	25	40	50
D6	M4X0.7P	M5X0.8P	M8X1.25P	M12X1.75P
D7	80	120	155	190
D8	50	70	90	120
L1	60	90	115	142
L2	25	40	50	80
L3	2.5	3	3.5	3.5
L4	1	1	1.5	1.5
L5	16	28	32	63
L6	3	5	7	8
L7	1	1	1.5	2
L8	1-stage	58	81	97
	2-stage	82.5	114	136.5
L9	4.5	4.8	7.2	10
L10	10	12.5	19	28
L11	13	17	20	25
C1 ⁴	46	70	100	130
C2 ⁴	M4X0.7P	M5X0.8P	M6X1P	M8X1.25P
C3 ⁴	≤ 12	≤ 16	≤ 24	≤ 32
C4 ⁴	30	34	40	50
C5 ¹ _{G6}	30	50	80	110
C6 ⁴	3.5	8	4	5
C7 ⁴	52	72	92	122
C8 ⁴	21.5	21.5	20	24
C9 ⁴	1-stage	104.5	142.5	167
	2-stage	129	175.5	206.5
C10 ⁴	14.5	15.5	13	16
B1 ^{h9}	5	6	8	12
H1	18	22.5	27	43

4. C1~C10 are motor specific dimensions (metric std shown). Refer to Apexdyna.com and Design Tool to view your specific motor mounting system.

PE / PG / PN / PB SERIES

Ordering Code

PE090

—

010

/

MOTOR

Gear Size:

PE: PE050, PE070, PE090, PE120, PE155

PG: PG040, PG060, PG080, PG080A, PG120, PG120A, PG160

PN: PN 023, PN034, PN042, PN056, PN075

PB: PB060, PB090, PB115, PB142

Ratio:

1 stage: 3, 4, 5, 7, 10

2 stage: 15, 16, 20, 25, 30, 35, 40, 50, 70, 100

Motor Designation:

Manufacture Type And Model

Ordering Example: PE090-010 / SIEMENS 1FT6 041-4AF71



APEX DYNAMICS, INC.

No.10, Keyuan 3rd Rd., Situn District, Taichung City 407, Taiwan (R.O.C.)

Tel: 886 4 23550219 / Fax: 886 4 23550218

E-mail: sales@apexdyna.com

Website: www.apexdyna.com

APEX-2009-03-P-SERIES-3.0V

