

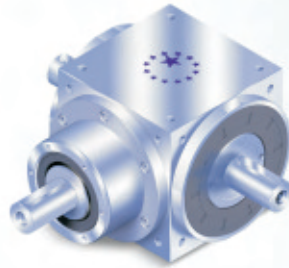

APEX DYNAMICS, INC.

AT-L >



AT-FL >



AT-H >

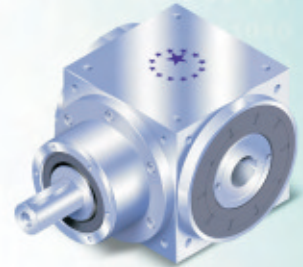

AT-FH >

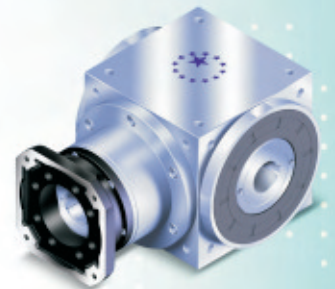

AT SERIES

*High Precision Spiral
Bevel Gearboxes*

AT-C >

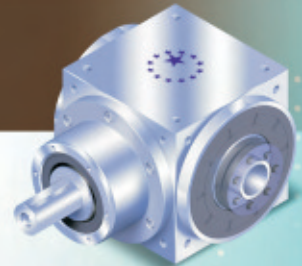

AT-FC >



Stainless

AT Series

Characteristic Highlights

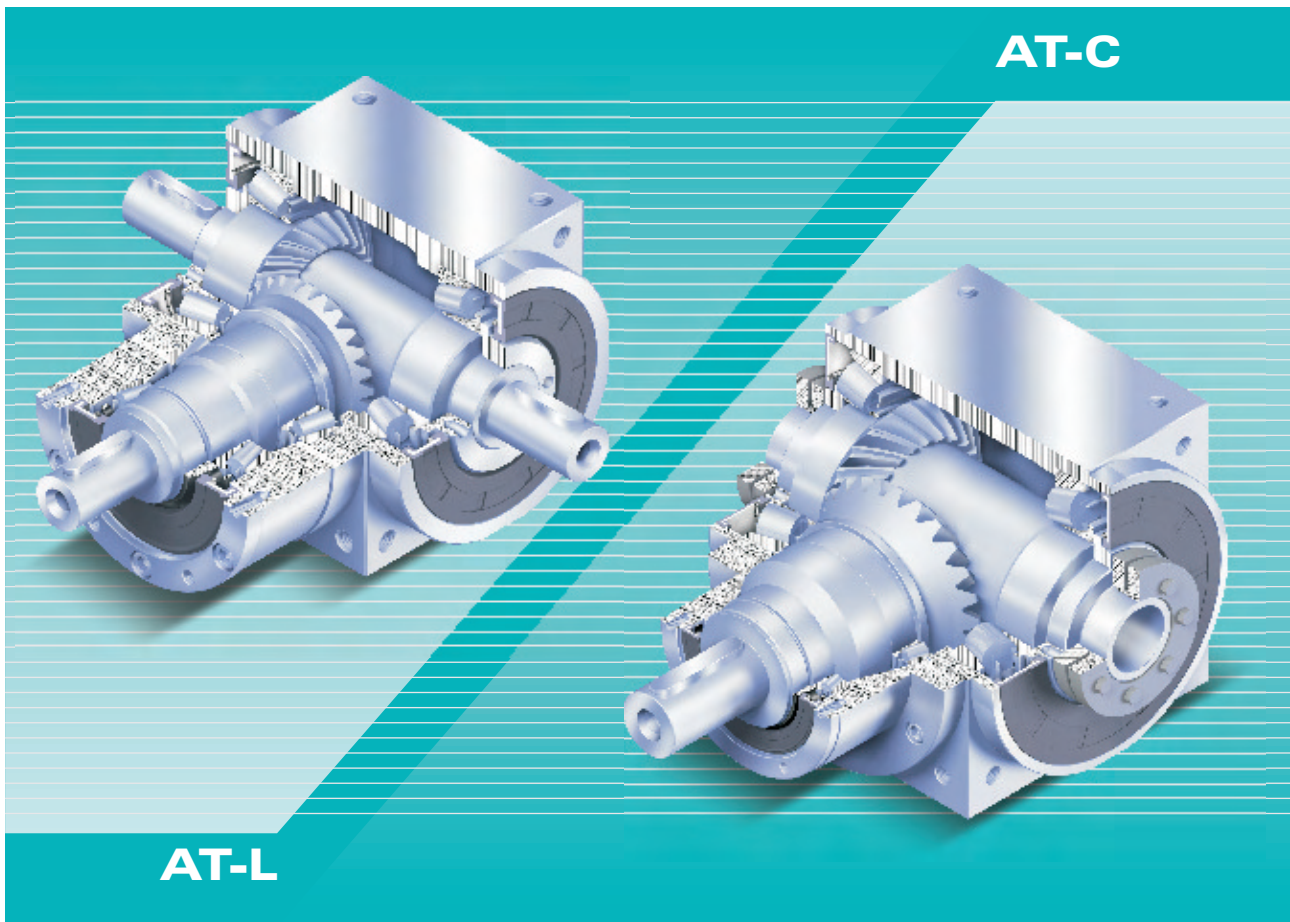

- Single Piece Stainless Steel housing for maximum rigidity and corrosion resistance. Multiple precision machined surfaces for ease of installation.
- Gearing design is optimized by state of the art software for highest performance. Carburized high tensile alloy steel is precision ground to exceed DIN 5 specifications.
- Stainless steel input and output shaft with multiple design configurations to meet all industry requirements.
- High precision ground spiral bevel gear sets are combined with optimized helical planetary geometry to create ratios up to 500:1.
- High torque. Low backlash and compact design are ideal for all servo application.
- Maintenance free, lubricated for life.

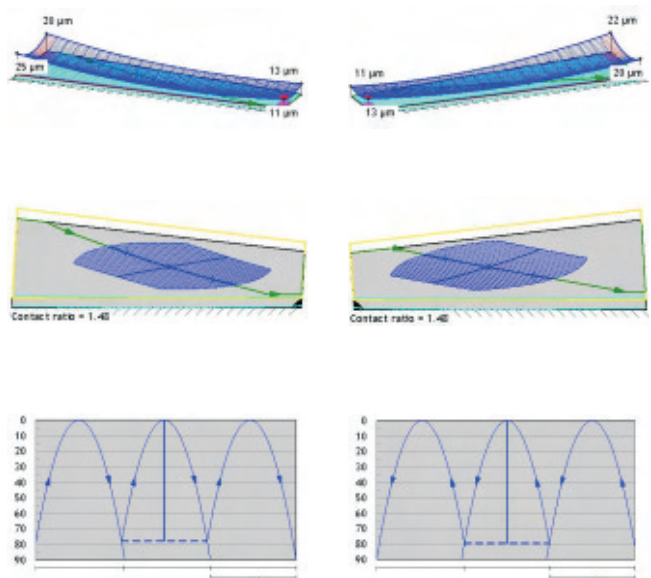

AT Shaft Type Series Specifications

Gearbox Performance

Model No.	Stage	Ratio ¹	AT065L	AT075L	AT090L	AT110L	AT140L	AT170L	AT210L	AT240L	AT280L	
			AT065L1	AT075L1	AT090L1	AT110L1	AT140L1	AT170L1	AT210L1	AT240L1	AT280L1	
			AT065H	AT075H	AT090H	AT110H	AT140H	AT170H	AT210H	AT240H	AT280H	
			AT065C	AT075C	AT090C	AT110C	AT140C	AT170C	AT210C	AT240C	AT280C	
Nominal Output Torque T_{2N}	Nm	1	1	25	45	78	150	360	585	1,300	2,150	3,200
			1.5	25	45	78	150	360	585	1,300	2,150	3,200
			2	24	42	68	150	330	544	1,220	2,010	3,050
			3	18	33	54	120	270	450	1,020	1,650	2,850
			4	13	28	48	100	224	376	860	1,410	2,300
		5	12	25	40	85	196	320	740	1,210	2,000	
Max. Acceleration Torque T_{2B}	Nm	1	1~5	1.5 times of Nominal Output Torque								
Max. Acceleration Input Speed n_{1B}	rpm	1	1~5	7,500	6,500	5,500	4,500	3,500	3,000	2,200	2,000	1,700
Standard Backlash*	arcmin	1	1~5	≤6	≤6	≤6	≤6	≤6	≤6	≤6	≤6	≤6
Max. Radial Load F_{1rB} ² Input d1	N	1	1~5	700	950	1,450	2,100	2,700	3,800	7,800	9,600	10,500
Max. Radial Load F_{2rB} ³ Output d2	N	1	1~5	900	1,100	1,700	2,700	4,800	6,600	11,500	16,000	18,000
Max. Axial Load F_{1aB} ² Input d1	N	1	1~5	350	425	725	1,050	1,350	1,900	3,900	4,800	5,250
Max. Axial Load F_{2aB} ³ Output d2	N	1	1~5	450	550	850	1,350	2,400	3,300	5,750	8,500	9,000
Service Life	hr	1	1~5	20,000*								
Efficiency η	%	1	1~5	≥98%								
Operating Temp	°C	1	1~5	-30°C ~ +100°C								
Lubrication		1	1~5	Synthetic lubrication oils								
Noise Level ($n_1=1500$ rpm)	db (A)	1	1~5	≤68	≤70	≤74	≤76	≤77	≤78	≤80	≤82	≤83

1. Ratio ($i=N_{in}/N_{out}$)

2. Apply to the input shaft center @ n_{1B}

3. Apply to the output shaft center @ n_{1B}

* S1 service life 10,000 hrs

* Backlash is measured at 2% Nominal Output Torque T_{2N}

Gearbox Inertia

Model No.	Stage	Ratio ¹	AT065L	AT075L	AT090L	AT110L	AT140L	AT170L	AT210L	AT240L	AT280L	
			AT065L1	AT075L1	AT090L1	AT110L1	AT140L1	AT170L1	AT210L1	AT240L1	AT280L1	
			AT065H	AT075H	AT090H	AT110H	AT140H	AT170H	AT210H	AT240H	AT280H	
			AT065C	AT075C	AT090C	AT110C	AT140C	AT170C	AT210C	AT240C	AT280C	
Mass Moments of Inertia J_1	kg · cm ²	1	1	0.51	1.30	3.16	7.70	23.57	58.99	195.40	369.34	799.12
			1.5	0.64	1.16	2.82	6.74	19.37	49.28	155.45	283.58	595.78
			2	0.44	1.11	2.70	6.31	17.75	45.35	140.24	249.74	511.76
			3	0.43	1.09	2.66	6.17	17.18	44.01	134.95	237.71	483.06
			4	0.43	1.09	2.65	6.13	17.06	43.70	133.58	234.72	476.26
		5	0.43	1.09	2.65	6.12	17.02	43.60	133.14	233.67	473.58	

Weight

Model No.	Stage	Ratio	AT065	AT075	AT090	AT110	AT140	AT170	AT210	AT240	AT280	
L Series	kg	1	1~5	2.6	4.2	6.8	11.6	19.8	34.8	66.2	98.1	155.7
L1 Series		1	1~5	2.6	4.1	6.7	11.5	19.5	34.2	65.1	96.6	153.4
H Series		1	1~5	2.5	3.9	6.4	11.0	18.1	31.6	60.0	89.4	143.4
C Series		1	1~5	2.8	4.2	6.9	11.4	19.6	33.7	63.3	97.9	149.1

AT-L Series

Dimensions (1-stage, Ratio $i=1\sim5$)

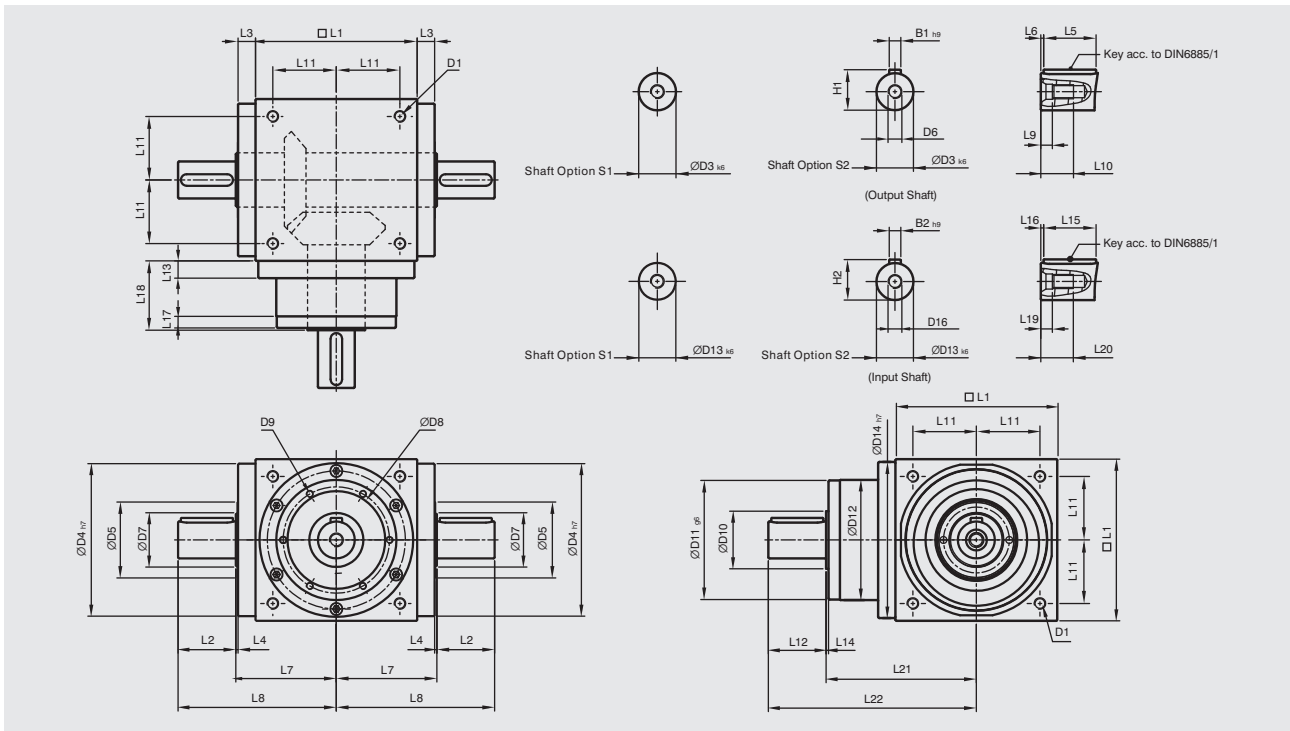

[unit: mm]

Dimension	AT065L	AT075L	AT090L	AT110L	AT140L	AT170L	AT210L	AT240L	AT280L
D1	M4	M6	M6	M8	M10	M12	M16	M16	M16
D3 _{k6}	13	16	18	22	32	40	50	55	60
D4 _{h7}	63	73	88	108	135	165	205	235	275
D5	31	35	43	53	68	83	104	124	144
D6	M4	M5	M5	M8	M12	M16	M16	M16	M20
D7	21	22	28	33	47	55	75	85	110
D8	53	62	76	95	92	114	142	160	176
D9	4xM4xL7	4xM5xL8	4xM5xL8	6xM6xL10	6xM6xL10	6xM8xL12.5	6xM8xL12.5	6xM8xL12.5	6xM10xL15
D10	15.4	20.4	25.8	35.8	49.8	59.3	79.3	92.3	102.3
D11 _{g6}	62.9	72.9	87	107	103	127	158	178	198
D12	62	72	86	106	104	128	160	180	200
D13 _{k6}	13	16	18	22	32	40	50	55	60
D14 _{h7}	63	73	88	108	135	165	205	235	275
D16	M4	M5	M5	M8	M12	M16	M16	M16	M20
L1	65	75	90	110	140	170	210	240	280
L2	19.5	30	35	40	50	60	75	85	110
L3	13	14.5	15	15	15	15	20	25	25
L4	2	2	2	2	2	2	2	2	2
L5	16	25	28	32	45	50	70	80	100
L6	2	2.5	3.5	4	2.5	5	2.5	2.5	5
L7	47.5	54	62	72	87	102	127	147	167
L8	67	84	97	112	137	162	202	232	277
L9	4.5	4.8	4.8	7.2	10	12	12	12	15
L10	10	12.5	12.5	19	28	36	36	36	42
L11	27	30	36	44	55	67	85	95	110
L12	19.5	30	35	40	50	60	75	85	110
L13	13	15	15	15	15	15	20	25	25
L14	2	2	2	2	2	2	2	2	2
L15	16	25	28	32	45	50	70	80	100
L16	2	2.5	3.5	4	2.5	5	2.5	2.5	5
L17	6	8	8	8	10	10	10	10	10
L18	43	52.5	55	60	60	70	90	105	120
L19	4.5	4.8	4.8	7.2	10	12	12	12	15
L20	10	12.5	12.5	19	28	36	36	36	42
L21	75.5	90	100	115	130	155	195	225	260
L22	95	120	135	155	180	215	270	310	370
B1 _{h9}	5	5	6	6	10	12	14	16	18
B2 _{h9}	5	5	6	6	10	12	14	16	18
H1	15	18	20.5	24.5	35	43	53.5	59	64
H2	15	18	20.5	24.5	35	43	53.5	59	64

AT-L1 Series

Dimensions (1-stage, Ratio $i=1\sim 5$)

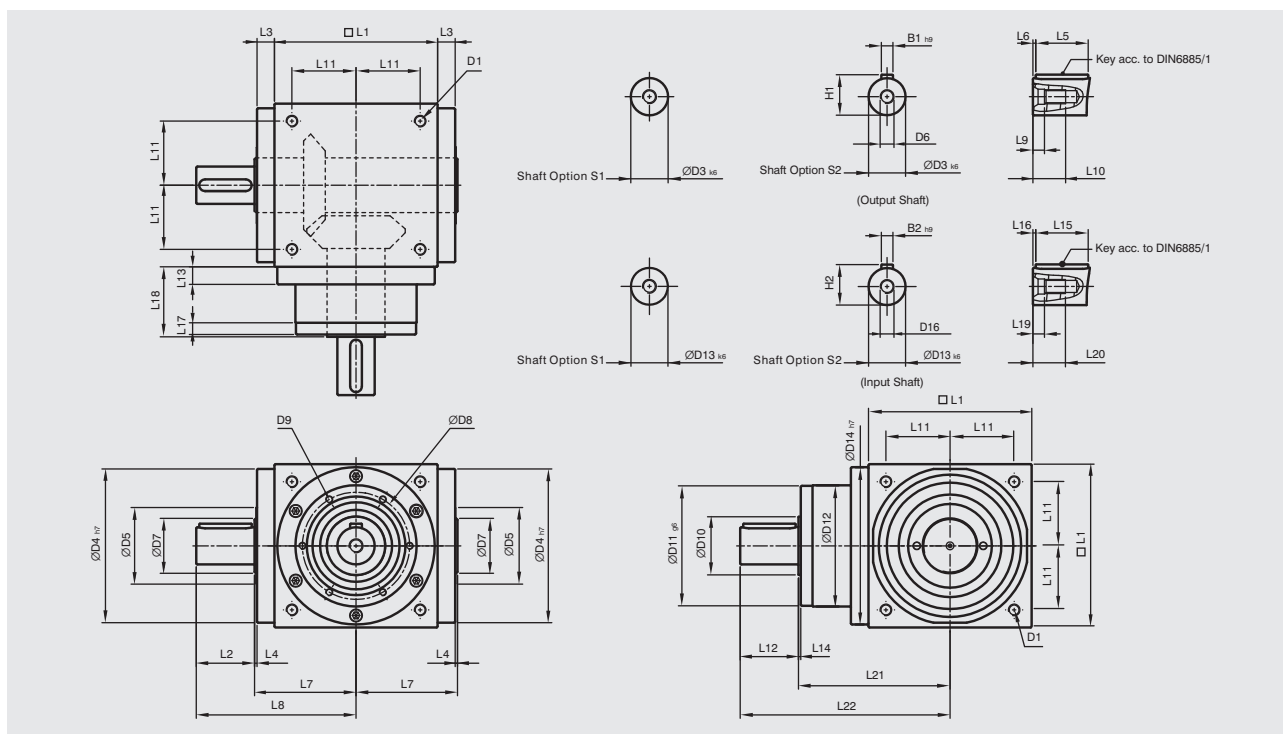

[unit: mm]

Dimension	AT065L1	AT075L1	AT090L1	AT110L1	AT140L1	AT170L1	AT210L1	AT240L1	AT280L1
D1	M4	M6	M6	M8	M10	M12	M16	M16	M16
D3 k6	13	16	18	22	32	40	50	55	60
D4 h7	63	73	88	108	135	165	205	235	275
D5	31	35	43	53	68	83	104	124	144
D6	M4	M5	M5	M8	M12	M16	M16	M16	M20
D7	21	22	28	33	47	55	75	85	110
D8	53	62	76	95	92	114	142	160	176
D9	4xM4xL7	4xM5xL8	4xM5xL8	6xM6xL10	6xM6xL10	6xM8xL12.5	6xM8xL12.5	6xM8xL12.5	6xM10xL15
D10	15.4	20.4	25.8	35.8	49.8	59.3	79.3	92.3	102.3
D11 g6	62.9	72.9	87	107	103	127	158	178	198
D12	62	72	86	106	104	128	160	180	200
D13 k6	13	16	18	22	32	40	50	55	60
D14 h7	63	73	88	108	135	165	205	235	275
D16	M4	M5	M5	M8	M12	M16	M16	M16	M20
L1	65	75	90	110	140	170	210	240	280
L2	19.5	30	35	40	50	60	75	85	110
L3	13	14.5	15	15	15	15	20	25	25
L4	2	2	2	2	2	2	2	2	2
L5	16	25	28	32	45	50	70	80	100
L6	2	2.5	3.5	4	2.5	5	2.5	2.5	5
L7	47.5	54	62	72	87	102	127	147	167
L8	67	84	97	112	137	162	202	232	277
L9	4.5	4.8	4.8	7.2	10	12	12	12	15
L10	10	12.5	12.5	19	28	36	36	36	42
L11	27	30	36	44	55	67	85	95	110
L12	19.5	30	35	40	50	60	75	85	110
L13	13	15	15	15	15	15	20	25	25
L14	2	2	2	2	2	2	2	2	2
L15	16	25	28	32	45	50	70	80	100
L16	2	2.5	3.5	4	2.5	5	2.5	2.5	5
L17	6	8	8	8	10	10	10	10	10
L18	43	52.5	55	60	60	70	90	105	120
L19	4.5	4.8	4.8	7.2	10	12	12	12	15
L20	10	12.5	12.5	19	28	36	36	36	42
L21	75.5	90	100	115	130	155	195	225	260
L22	95	120	135	155	180	215	270	310	370
B1 h9	5	5	6	6	10	12	14	16	18
B2 h9	5	5	6	6	10	12	14	16	18
H1	15	18	20.5	24.5	35	43	53.5	59	64
H2	15	18	20.5	24.5	35	43	53.5	59	64

AT-H Series

Dimensions (1-stage, Ratio $i=1\sim5$)

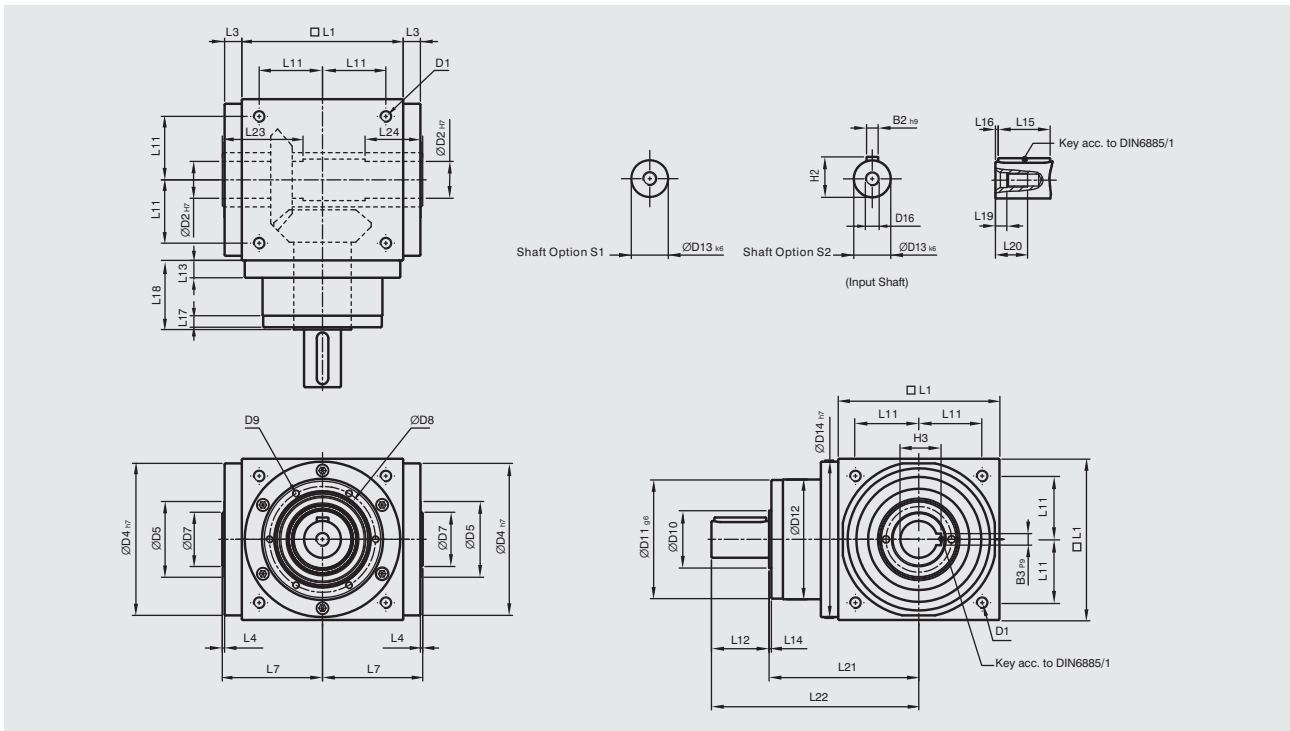

[unit: mm]

Dimension	AT065H	AT075H	AT090H	AT110H	AT140H	AT170H	AT210H	AT240H	AT280H
D1	M4	M6	M6	M8	M10	M12	M16	M16	M16
D2 _{H7}	13	14	18	22	32	40	50	55	60
D4 _{H7}	63	73	88	108	135	165	205	235	275
D5	31	35	43	53	68	83	104	124	144
D7	21	22	28	33	47	55	75	85	110
D8	53	62	76	95	92	114	142	160	176
D9	4xM4xL7	4xM5xL8	4xM5xL8	6xM6xL10	6xM6xL10	6xM8xL12.5	6xM8xL12.5	6xM8xL12.5	6xM10xL15
D10	15.4	20.4	25.8	35.8	49.8	59.3	79.3	92.3	102.3
D11 _{g6}	62.9	72.9	87	107	103	127	158	178	198
D12	62	72	86	106	104	128	160	180	200
D13 _{k6}	13	16	18	22	32	40	50	55	60
D14 _{H7}	63	73	88	108	135	165	205	235	275
D16	M4	M5	M5	M8	M12	M16	M16	M16	M20
L1	65	75	90	110	140	170	210	240	280
L3	13	14.5	15	15	15	15	20	25	25
L4	2	2	2	2	2	2	2	2	2
L7	47.5	54	62	72	87	102	127	147	167
L11	27	30	36	44	55	67	85	95	110
L12	19.5	30	35	40	50	60	75	85	110
L13	13	15	15	15	15	15	20	25	25
L14	2	2	2	2	2	2	2	2	2
L15	16	25	28	32	45	50	70	80	100
L16	2	2.5	3.5	4	2.5	5	2.5	2.5	5
L17	6	8	8	8	10	10	10	10	10
L18	43	52.5	55	60	60	70	90	105	120
L19	4.5	4.8	4.8	7.2	10	12	12	12	15
L20	10	12.5	12.5	19	28	36	36	36	42
L21	75.5	90	100	115	130	155	195	225	260
L22	95	120	135	155	180	215	270	310	370
L23	40	47	52	53	70	80	95	115	115
L24	30	32	35	35	50	55	65	80	80
B2 _{H9}	5	5	6	6	10	12	14	16	18
B3 _{P9}	5	5	6	6	10	12	14	16	18
H2	15	18	20.5	24.5	35	43	53.5	59	64
H3	15.3	16.3	20.8	24.8	35.3	43.3	53.8	59.3	64.4

AT-C Series

Dimensions (1-stage, Ratio $i=1 \sim 5$)

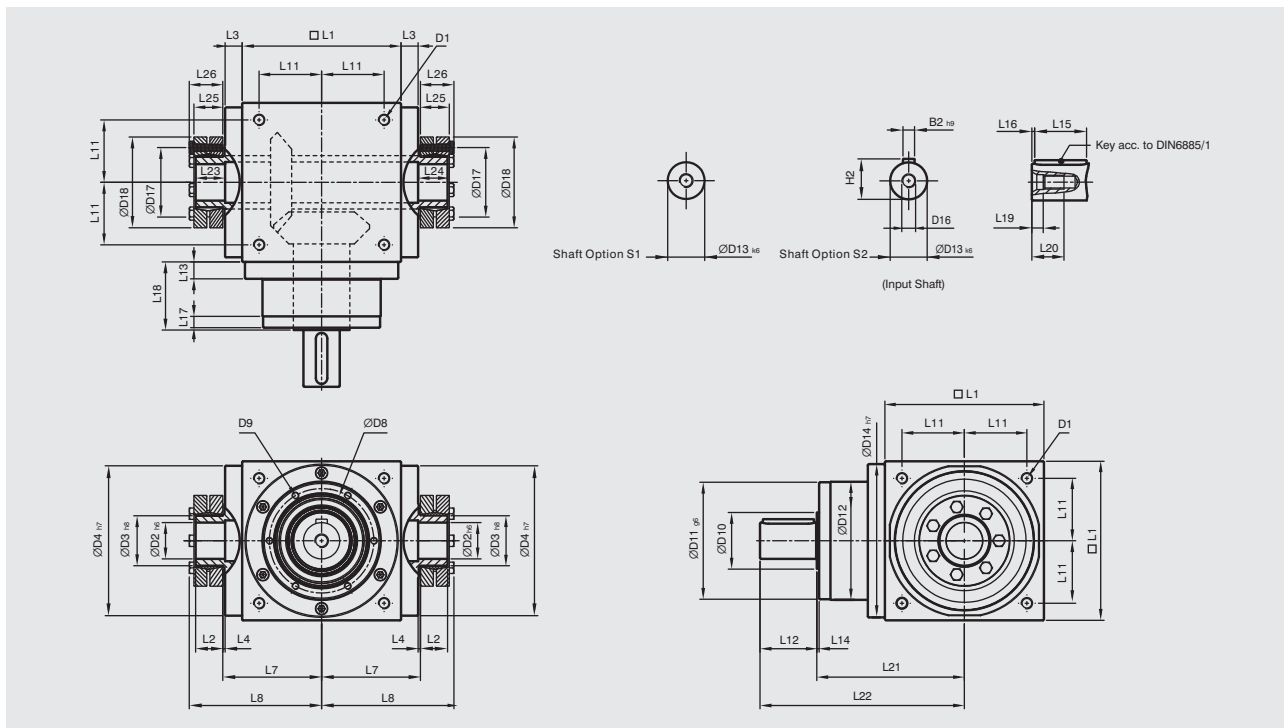

● Standard accessory includes 2 shrink disk power lock units.

[unit: mm]

Dimension	AT065C	AT075C	AT090C	AT110C	AT140C	AT170C	AT210C	AT240C	AT280C
D1	M4	M6	M6	M8	M10	M12	M16	M16	M16
D2 H6	13	14	18	22	32	40	50	55	60
D3 h8	16	16	22	25	44	50	62	68	75
D4 h7	63	73	88	108	135	165	205	235	275
D8	53	62	76	95	92	114	142	160	176
D9	4xM4xL7	4xM5xL8	4xM5xL8	6xM6xL10	6xM6xL10	6xM8xL12.5	6xM8xL12.5	6xM8xL12.5	6xM10xL15
D10	15.4	20.4	25.8	35.8	49.8	59.3	79.3	92.3	102.3
D11 g6	62.9	72.9	87	107	103	127	158	178	198
D12	62	72	86	106	104	128	160	180	200
D13 k6	13	16	18	22	32	40	50	55	60
D14 h7	63	73	88	108	135	165	205	235	275
D16	M4	M5	M5	M8	M12	M16	M16	M16	M20
D17	26	26	36	38	61	70	86	86	100
D18	41	41	50	50	80	90	110	115	138
L1	65	75	90	110	140	170	210	240	280
L2	14	14	18	18	24	26	29	29	30.5
L3	13	14.5	15	15	15	15	20	25	25
L4	2	2	2	2	2	2	2	2	2
L7	47.5	54	62	72	87	102	127	147	167
L8	66	72.5	85	95	116.5	133.5	161.5	181.5	205
L11	27	30	36	44	55	67	85	95	110
L12	19.5	30	35	40	50	60	75	85	110
L13	13	15	15	15	15	15	20	25	25
L14	2	2	2	2	2	2	2	2	2
L15	16	25	28	32	45	50	70	80	100
L16	2	2.5	3.5	4	2.5	5	2.5	2.5	5
L17	6	8	8	8	10	10	10	10	10
L18	43	52.5	55	60	60	70	90	105	120
L19	4.5	4.8	4.8	7.2	10	12	12	12	15
L20	10	12.5	12.5	19	28	36	36	36	42
L21	75.5	90	100	115	130	155	195	225	260
L22	95	120	135	155	180	215	270	310	370
L23	15	15	20	20	26	28	31	31	32.5
L24	15	15	20	20	26	28	31	31	32.5
L25	15	15	19.5	19.5	25.5	27.5	30.5	30.5	32.5
L26	18.5	18.5	23	23	29.5	31.5	34.5	34.5	38
B2 h9	5	5	6	6	10	12	14	16	18
H2	15	18	20.5	24.5	35	43	53.5	59	64

AT Flange Type Series

Specifications

Gearbox Performance

Model No.	Stage	Ratio ¹	AT065FL	AT075FL	AT090FL	AT110FL	AT140FL	AT170FL	AT210FL	AT240FL	AT280FL		
			AT065FL1	AT075FL1	AT090FL1	AT110FL1	AT140FL1	AT170FL1	AT210FL1	AT240FL1	AT280FL1		
			AT065FH	AT075FH	AT090FH	AT110FH	AT140FH	AT170FH	AT210FH	AT240FH	AT280FH		
			AT065FC	AT075FC	AT090FC	AT110FC	AT140FC	AT170FC	AT210FC	AT240FC	AT280FC		
Nominal Output Torque T_{2N}	Nm	1	1	25	45	78	150	360	585	1,300	2,150	3,200	
			1.5	25	45	78	150	360	585	1,300	2,150	3,200	
			2	24	42	68	150	330	544	1,220	2,010	3,050	
			3	18	33	54	120	270	450	1,020	1,650	2,850	
			4	13	28	48	100	224	376	860	1,410	2,300	
			5	12	25	40	85	196	320	740	1,210	2,000	
		2	7	12	12	33	91	91	195	358	358		
			10	24	28	68	150	208	208	430	846	846	
			15	18	33	54	120	270	312	645	1,269	1,269	
			20	13	28	48	100	224	376	860	1,410	1,692	
			25	12	25	40	85	196	320	740	1,210	2,000	
			35	12	25	40	85	196	320	740	1,210	1,790	
	3	50	12	25	40	85	196	320	740	1,210	1,465		
		75	-	-	-	120	210	312	585	1,269	1,269		
		100	-	-	-	100	224	376	780	1,410	1,692		
		125	-	-	-	85	196	320	740	1,210	2,000		
		150	-	-	-	120	135	312	390	975	975		
		200	-	-	-	100	180	376	520	1,300	1,300		
		250	-	-	-	85	196	320	650	1,210	1,625		
		350	-	-	-	85	196	320	740	1,210	1,790		
	500	-	-	-	85	196	320	740	1,210	1,465			
	Max. Acceleration Torque T_{2B}	Nm	1,2,3	1~500	1.5 times of Nominal Output Torque								
	Max. Acceleration Input Speed n_{1B}	rpm	1	1~5	7,500	6,500	5,500	4,500	3,500	3,000	2,200	2,000	1,700
			2	7~50	8,000	8,000	6,000	6,000	6,000	6,000	4,800	3,600	3,600
3			75~500	-	-	-	8,000	8,000	6,000	6,000	6,000	6,000	
Standard Backlash [*]	arcmin	1	1~5	≤6	≤6	≤6	≤6	≤6	≤6	≤6	≤6	≤6	
		2	7~50	≤8	≤8	≤8	≤8	≤8	≤8	≤8	≤8	≤8	
		3	75~500	-	-	-	≤10	≤10	≤10	≤10	≤10	≤10	
Max. Radial Load F_{2RB} ² Output d2	N	1,2,3	1~500	900	1,100	1,700	2,700	4,800	6,600	11,500	16,000	18,000	
Max. Axial Load F_{2aB} ² Output d2	N	1,2,3	1~500	450	550	850	1,350	2,400	3,300	5,750	8,500	9,000	
Service Life	hr	1,2,3	1~500	20,000 [*]									
Efficiency η	%	1	1~5	≥98%									
		2,3	7~500	≥94%									
Operating Temp	°C	1,2,3	1~500	-30°C ~ +100°C									
Lubrication		1,2,3	1~500	Synthetic lubrication oils									
Noise Level ($n_1=1500$ rpm)	db (A)	1,2,3	1~500	≤71	≤72	≤76	≤77	≤78	≤79	≤81	≤83	≤84	

1. Ratio ($i=N_1/N_{out}$)

* S1 service life 10,000 hrs

2. Apply to the output shaft center @ n_{1B}

* Backlash is measured at 2% Nominal Output Torque T_{2N}

AT Flange Type Series Specifications

Gearbox Inertia

Model No.	Stage	Ratio ¹	AT065FL	AT075FL	AT090FL	AT110FL	AT140FL	AT170FL	AT210FL	AT240FL	AT280FL	
			AT065FL1	AT075FL1	AT090FL1	AT110FL1	AT140FL1	AT170FL1	AT210FL1	AT240FL1	AT280FL1	
			AT065FH	AT075FH	AT090FH	AT110FH	AT140FH	AT170FH	AT210FH	AT240FH	AT280FH	
			AT065FC	AT075FC	AT090FC	AT110FC	AT140FC	AT170FC	AT210FC	AT240FC	AT280FC	
Mass Moments of Inertia J ₁	1	1	0.51	1.30	3.14	7.62	23.54	59.09	195.96	365.38	787.63	
		1.5	0.46	1.15	2.80	6.65	19.34	49.38	156.02	279.62	584.28	
		2	0.44	1.10	2.68	6.23	17.72	45.44	140.80	245.78	500.26	
		3	0.43	1.09	2.64	6.08	17.16	44.11	135.51	233.75	471.56	
		4	0.43	1.08	2.63	6.05	17.03	43.79	134.14	230.77	464.76	
		5	0.43	1.08	2.63	6.04	16.99	43.69	133.71	229.71	462.08	
		2	7	0.16	0.16	0.59	3.27	3.27	3.27	12.05	34.07	34.07
			10	0.16	0.16	0.59	3.28	3.28	3.28	12.10	34.24	34.24
			15	0.16	0.16	0.59	3.28	3.28	3.28	12.10	34.24	34.24
			20	0.16	0.16	0.59	3.28	3.28	3.28	12.10	34.24	34.24
			25	0.16	0.16	0.59	3.28	3.28	3.28	12.10	34.24	34.24
			35	0.16	0.16	0.59	3.27	3.27	3.27	12.05	34.07	34.07
			50	0.16	0.16	0.59	3.26	3.26	3.26	12.03	34.02	34.02
		3	75	-	-	-	3.28	3.28	3.28	12.10	34.24	34.24
	100		-	-	-	3.28	3.28	3.28	12.10	34.24	34.24	
	125		-	-	-	3.28	3.28	3.28	12.10	34.24	34.24	
	150		-	-	-	3.26	3.26	3.26	12.03	34.02	34.02	
	200		-	-	-	3.26	3.26	3.26	12.03	34.02	34.02	
	250		-	-	-	3.26	3.26	3.26	12.03	34.02	34.02	
	350		-	-	-	3.26	3.26	3.26	12.03	34.02	34.02	
	500		-	-	-	3.26	3.26	3.26	12.03	34.02	34.02	

Weight

Model No.	Stage	Ratio ¹	AT065	AT075	AT090	AT110	AT140	AT170	AT210	AT240	AT280
FL Series	1	1~5	2.8	4.4	7.1	12.1	20.9	36.1	69.4	101.2	158.3
	2	7~50	3.2	4.8	8.1	14.3	24.2	38.5	74.1	112.4	171.0
	3	75~500	-	-	-	13.9	23.7	38.8	73.4	110.2	168.7
FL1 Series	1	1~5	2.7	4.3	7.1	11.9	20.3	35.5	68.3	99.6	156.0
	2	7~50	3.2	4.8	8.0	14.2	23.9	37.9	73.0	110.8	168.6
	3	75~500	-	-	-	13.8	23.4	38.2	72.3	108.6	166.4
FH Series	1	1~5	2.6	4.1	6.7	11.4	18.9	32.9	63.2	92.5	146.0
	2	7~50	3.1	4.6	7.7	13.6	22.4	35.3	67.9	103.7	158.7
	3	75~500	-	-	-	13.3	21.9	35.6	67.2	101.5	156.5
FC Series	1	1~5	2.9	4.4	7.2	11.8	20.4	35.0	66.5	96.0	151.7
	2	7~50	3.3	4.9	8.2	14.1	24.1	37.4	71.2	107.2	164.4
	3	75~500	-	-	-	13.7	23.5	37.5	70.5	105.0	162.2

AT-FL Series

Dimensions (1-stage, Ratio $i=1\sim5$)

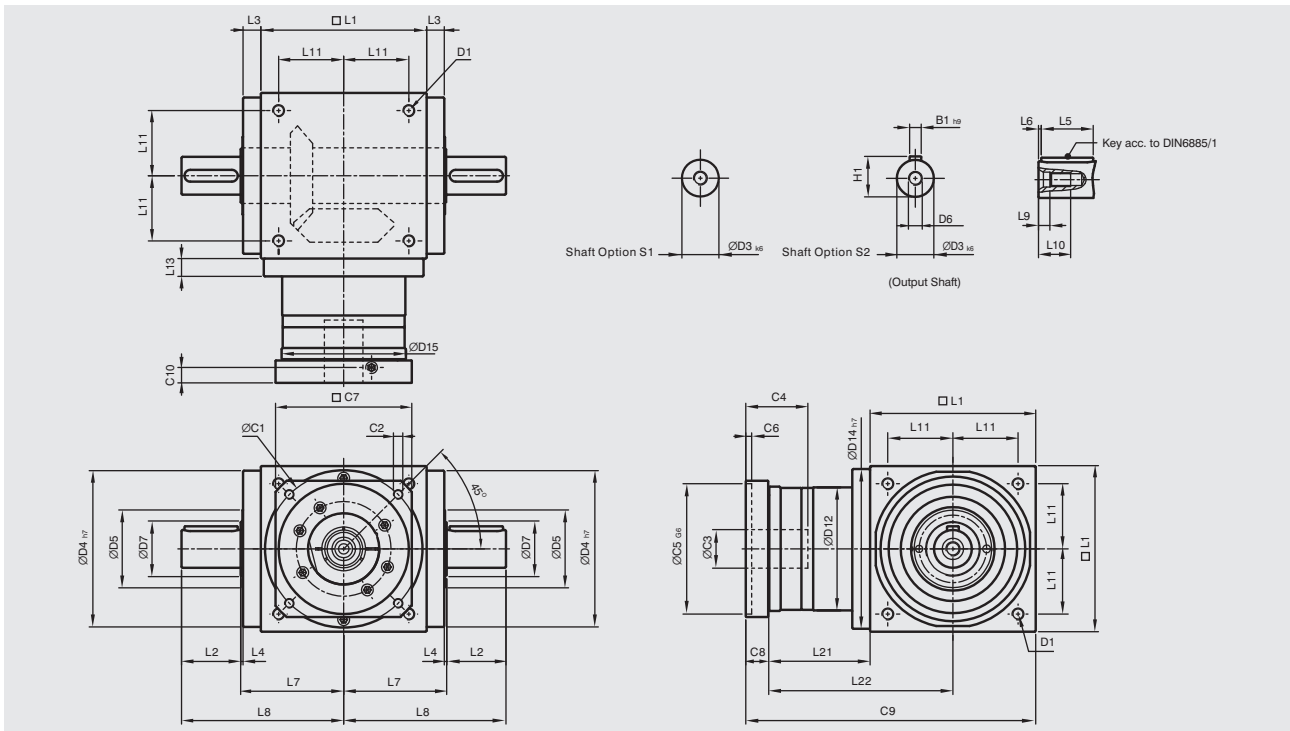

[unit: mm]

Dimension	AT065FL	AT075FL	AT090FL	AT110FL	AT140FL	AT170FL	AT210FL	AT240FL	AT280FL
D1	M4	M6	M6	M8	M10	M12	M16	M16	M16
D3 _{k6}	13	16	18	22	32	40	50	55	60
D4 _{h7}	63	73	88	108	135	165	205	235	275
D5	31	35	43	53	68	83	104	124	144
D6	M4	M5	M5	M8	M12	M16	M16	M16	M20
D7	21	22	28	33	47	55	75	85	110
D12	62	72	86	106	104	128	160	180	200
D14 _{h7}	63	73	88	108	135	165	205	235	275
D15	62.9	72.9	87	107	105	127	158	178	198
L1	65	75	90	110	140	170	210	240	280
L2	19.5	30	35	40	50	60	75	85	110
L3	13	14.5	15	15	15	15	20	25	25
L4	2	2	2	2	2	2	2	2	2
L5	16	25	28	32	45	50	70	80	100
L6	2	2.5	3.5	4	2.5	5	2.5	2.5	5
L7	47.5	54	62	72	87	102	127	147	167
L8	67	84	97	112	137	162	202	232	277
L9	4.5	4.8	4.8	7.2	10	12	12	12	15
L10	10	12.5	12.5	19	28	36	36	36	42
L11	27	30	36	44	55	67	85	95	110
L13	13	15	15	15	15	15	20	25	25
L21	49	60.5	63	69.5	85.5	95	130	144.5	135
L22	81.5	98	108	124.5	155.5	180	235	264.5	275
C1 ³	46	70	100	100	130	165	215	215	235
C2 ³	M4	M5	M6	M6	M8	M10	M12	M12	M12
C3 ³	★ ≤11 / ≤12	★ ≤14 / ≤15.875 / ≤16	≤19	≤24	≤32	≤38	≤42	≤48	≤55
C4 ³	30	34	40	40	50	60	85	85	116
C5 ³ _{G6}	30	50	80	80	110	130	180	180	200
C6 ³	3.5	8	4	4	5	6	6	6	6
C7 ³	42	60	90	90	115	142	190	190	220
C8 ³	19.5	19	17	17	19.5	22.5	29	29	63
C9 ³	133.5	154.5	170	196.5	245	287.5	369	413.5	478
C10 ³	13.25	13.5	10.75	10.75	13	15	20.75	20.75	53.5
B1 _{h9}	5	5	6	6	10	12	14	16	18
H1	15	18	20.5	24.5	35	43	53.5	59	64

3. C1~C10 are motor specific dimensions (metric std shown). Refer to Apexdyna.com and Design Tool to view your specific motor mounting system.

★ AT065FLM1 offers C3 ≤12 option. ★ AT075FLM1 offers C3 ≤16 option. ★ AT075FLM2 offers C3 ≤15.875 option.

AT-FL Series

Dimensions (2-stage, Ratio $i=7\sim 50$)

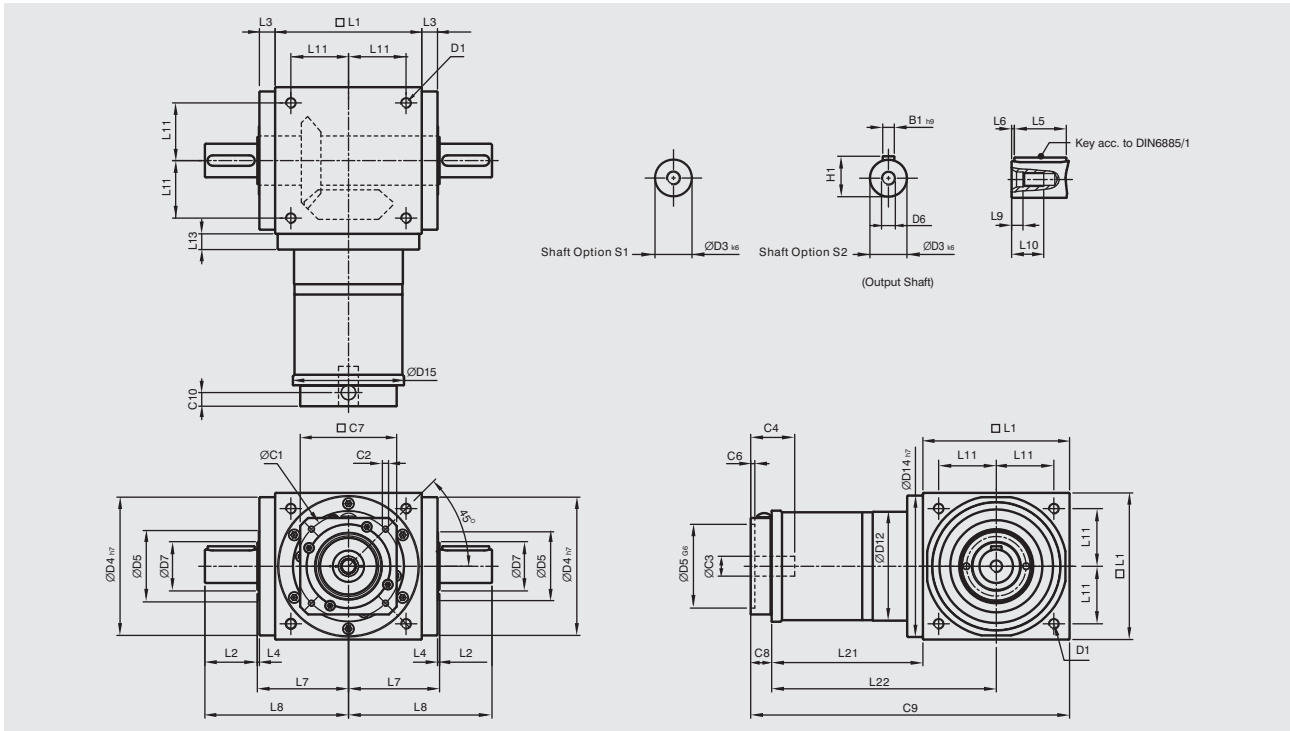

[unit: mm]

Dimension	AT065FL	AT075FL	AT090FL	AT110FL	AT140FL	AT170FL	AT210FL	AT240FL	AT280FL
D1	M4	M6	M6	M8	M10	M12	M16	M16	M16
D3 _{k6}	13	16	18	22	32	40	50	55	60
D4 _{h7}	63	73	88	108	135	165	205	235	275
D5	31	35	43	53	68	83	104	124	144
D6	M4	M5	M5	M8	M12	M16	M16	M16	M20
D7	21	22	28	33	47	55	75	85	110
D12	62	72	86	106	104	128	160	180	200
D14 _{h7}	63	73	88	108	135	165	205	235	275
D15	62.9	72.9	87	107	106	127	158	178	198
L1	65	75	90	110	140	170	210	240	280
L2	19.5	30	35	40	50	60	75	85	110
L3	13	14.5	15	15	15	15	20	25	25
L4	2	2	2	2	2	2	2	2	2
L5	16	25	28	32	45	50	70	80	100
L6	2	2.5	3.5	4	2.5	5	2.5	2.5	5
L7	47.5	54	62	72	87	102	127	147	167
L8	67	84	97	112	137	162	202	232	277
L9	4.5	4.8	4.8	7.2	10	12	12	12	15
L10	10	12.5	12.5	19	28	36	36	36	42
L11	27	30	36	44	55	67	85	95	110
L13	13	15	15	15	15	15	20	25	25
L21	75	84.5	99	122	144.5	157.5	206.5	239	248
L22	107.5	122	144	177	214.5	242.5	311.5	359	388
C1 ⁴	46	46	70	100	100	100	130	165	165
C2 ⁴	M4	M4	M5	M6	M6	M6	M8	M10	M10
C3 ⁴	≤12	≤12	≤16	≤24	≤24	≤24	≤32	≤38	≤38
C4 ⁴	30	30	34	40	40	40	50	60	60
C5 ⁴ _{G6}	30	30	50	80	80	80	110	130	130
C6 ⁴	3.5	3.5	8	4	4	4	5	6	6
C7 ⁴	42	42	60	92	92	92	115	142	142
C8 ⁴	21.5	21.5	21.5	20	20	20	24	31	31
C9 ⁴	161.5	181	210.5	252	304.5	347.5	440.5	510	559
C10 ⁴	14.5	14.5	15.5	13	13	13	16	21	21
B1 _{h9}	5	5	6	6	10	12	14	16	18
H1	15	18	20.5	24.5	35	43	53.5	59	64

4. C1-C10 are motor specific dimensions (metric std shown). Refer to Apexdyna.com and Design Tool to view your specific motor mounting system.

AT-FL Series

Dimensions (3-stage, Ratio $i=75\sim 500$)

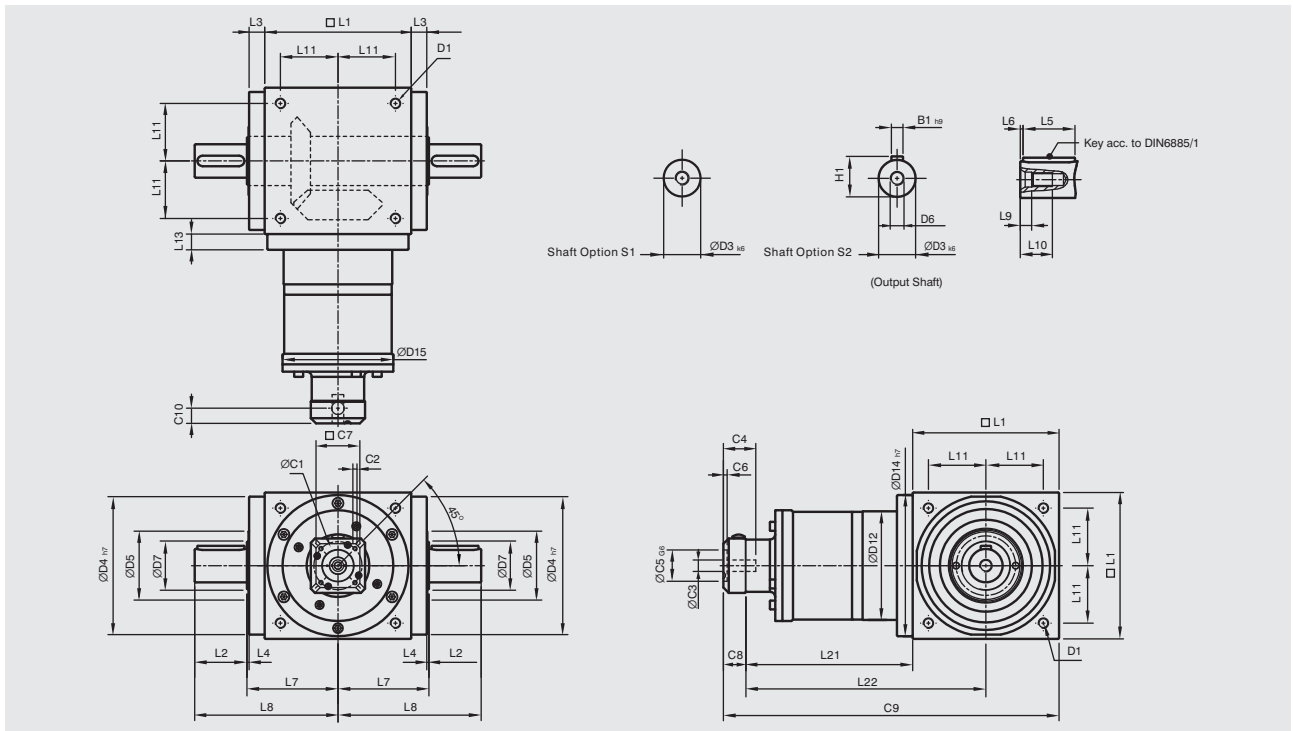

[unit: mm]

Dimension	AT110FL	AT140FL	AT170FL	AT210FL	AT240FL	AT280FL
D1	M8	M10	M12	M16	M16	M16
D3 _{k6}	22	32	40	50	55	60
D4 _{h7}	108	135	165	205	235	275
D5	53	68	83	104	124	144
D6	M8	M12	M16	M16	M16	M20
D7	33	47	55	75	85	110
D12	106	104	128	160	180	200
D14 _{h7}	108	135	165	205	235	275
D15	107	106	127	158	178	198
L1	110	140	170	210	240	280
L2	40	50	60	75	85	110
L3	15	15	15	20	25	25
L4	2	2	2	2	2	2
L5	32	45	50	70	80	100
L6	4	2.5	5	2.5	2.5	5
L7	72	87	102	127	147	167
L8	112	137	162	202	232	277
L9	7.2	10	12	12	12	15
L10	19	28	36	36	36	42
L11	44	55	67	85	95	110
L13	15	15	15	20	25	25
L21	136.5	159.5	183.5	226	269	278
L22	191.5	229.5	268.5	331	389	418
C1 ⁵	46	46	70	70	100	100
C2 ⁵	M4	M4	M5	M5	M6	M6
C3 ⁵	≤12	≤12	≤16	≤16	≤24	≤24
C4 ⁵	30	30	34	34	40	40
C5 ⁵ _{G6}	30	30	50	50	80	80
C6 ⁵	3.5	3.5	8	8	4	4
C7 ⁵	42	42	60	60	92	92
C8 ⁵	21.5	21.5	21.5	21.5	20	20
C9 ⁵	268	321	375	457.5	529	578
C10 ⁵	14.5	14.5	15.5	15.5	13	13
B1 _{h9}	6	10	12	14	16	18
H1	24.5	35	43	53.5	59	64

5. C1~C10 are motor specific dimensions (metric std shown). Refer to Apexdyna.com and Design Tool to view your specific motor mounting system.

AT-FL1 Series

Dimensions (1-stage, Ratio $i=1\sim5$)

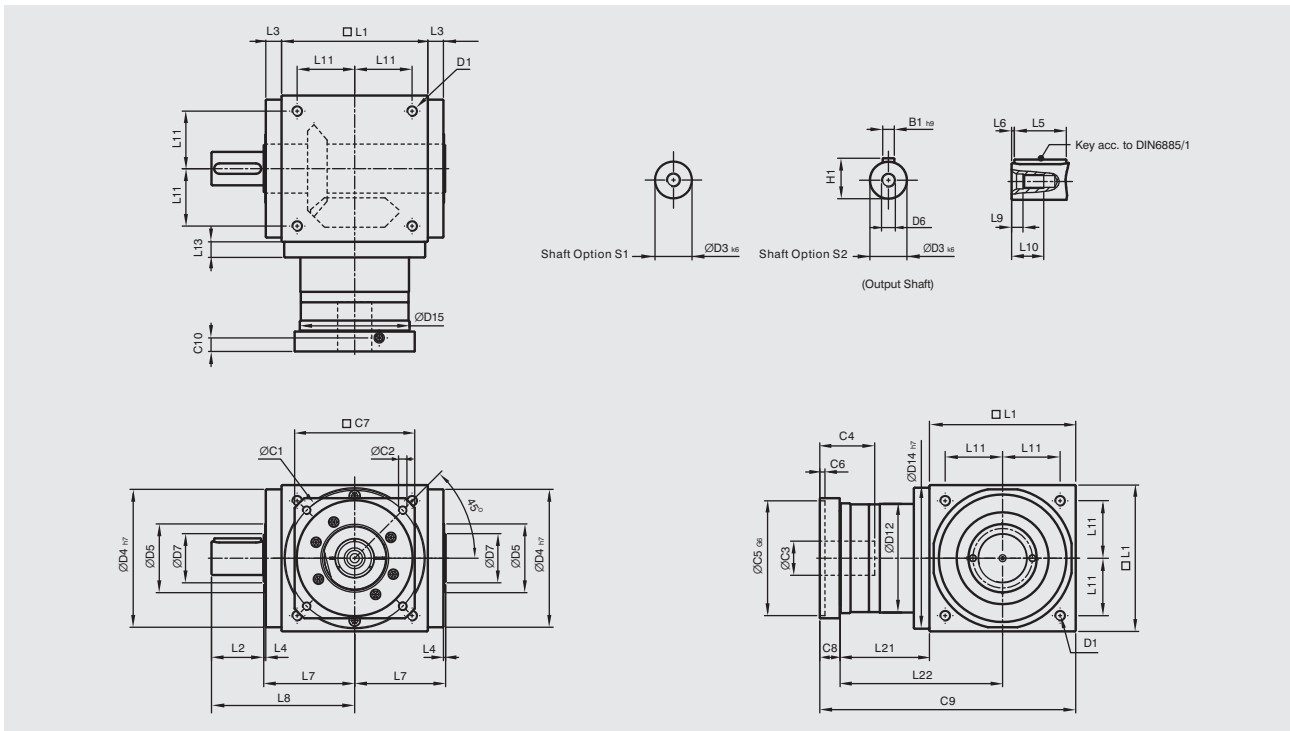

[unit: mm]

Dimension	AT065FL1	AT075FL1	AT090FL1	AT110FL1	AT140FL1	AT170FL1	AT210FL1	AT240FL1	AT280FL1
D1	M4	M6	M6	M8	M10	M12	M16	M16	M16
D3 k6	13	16	18	22	32	40	50	55	60
D4 h7	63	73	88	108	135	165	205	235	275
D5	31	35	43	53	68	83	104	124	144
D6	M4	M5	M5	M8	M12	M16	M16	M16	M20
D7	21	22	28	33	47	55	75	85	110
D12	62	72	86	106	104	128	160	180	200
D14 h7	63	73	88	108	135	165	205	235	275
D15	62.9	72.9	87	107	105	127	158	178	198
L1	65	75	90	110	140	170	210	240	280
L2	19.5	30	35	40	50	60	75	85	110
L3	13	14.5	15	15	15	15	20	25	25
L4	2	2	2	2	2	2	2	2	2
L5	16	25	28	32	45	50	70	80	100
L6	2	2.5	3.5	4	2.5	5	2.5	2.5	5
L7	47.5	54	62	72	87	102	127	147	167
L8	67	84	97	112	137	162	202	232	277
L9	4.5	4.8	4.8	7.2	10	12	12	12	15
L10	10	12.5	12.5	19	28	36	36	36	42
L11	27	30	36	44	55	67	85	95	110
L13	13	15	15	15	15	15	20	25	25
L21	49	60.5	63	69.5	85.5	95	130	144.5	135
L22	81.5	98	108	124.5	155.5	180	235	264.5	275
C1 ⁶	46	70	100	100	130	165	215	215	235
C2 ⁶	M4	M5	M6	M6	M8	M10	M12	M12	M12
C3 ⁶	★ ≤11 / ≤12	★ ≤14 / ≤15.875 / ≤16	≤19	≤24	≤32	≤38	≤42	≤48	≤55
C4 ⁶	30	34	40	40	50	60	85	85	116
C5 ^{6 G6}	30	50	80	80	110	130	180	180	200
C6 ⁶	3.5	8	4	4	5	6	6	6	6
C7 ⁶	42	60	90	90	115	142	190	190	220
C8 ⁶	19.5	19	17	17	19.5	22.5	29	29	63
C9 ⁶	133.5	154.5	170	196.5	245	287.5	369	413.5	478
C10 ⁶	13.25	13.5	10.75	10.75	13	15	20.75	20.75	53.5
B1 h9	5	5	6	6	10	12	14	16	18
H1	15	18	20.5	24.5	35	43	53.5	59	64

6. C1~C10 are motor specific dimensions (metric std shown). Refer to Apexdyna.com and Design Tool to view your specific motor mounting system.

★ AT065FL1M1 offers C3 ≤12 option. ★ AT075FL1M1 offers C3 ≤16 option. ★ AT075FL1M2 offers C3 ≤15.875 option.

AT-FL1 Series

Dimensions (2-stage, Ratio $i=7\sim 50$)

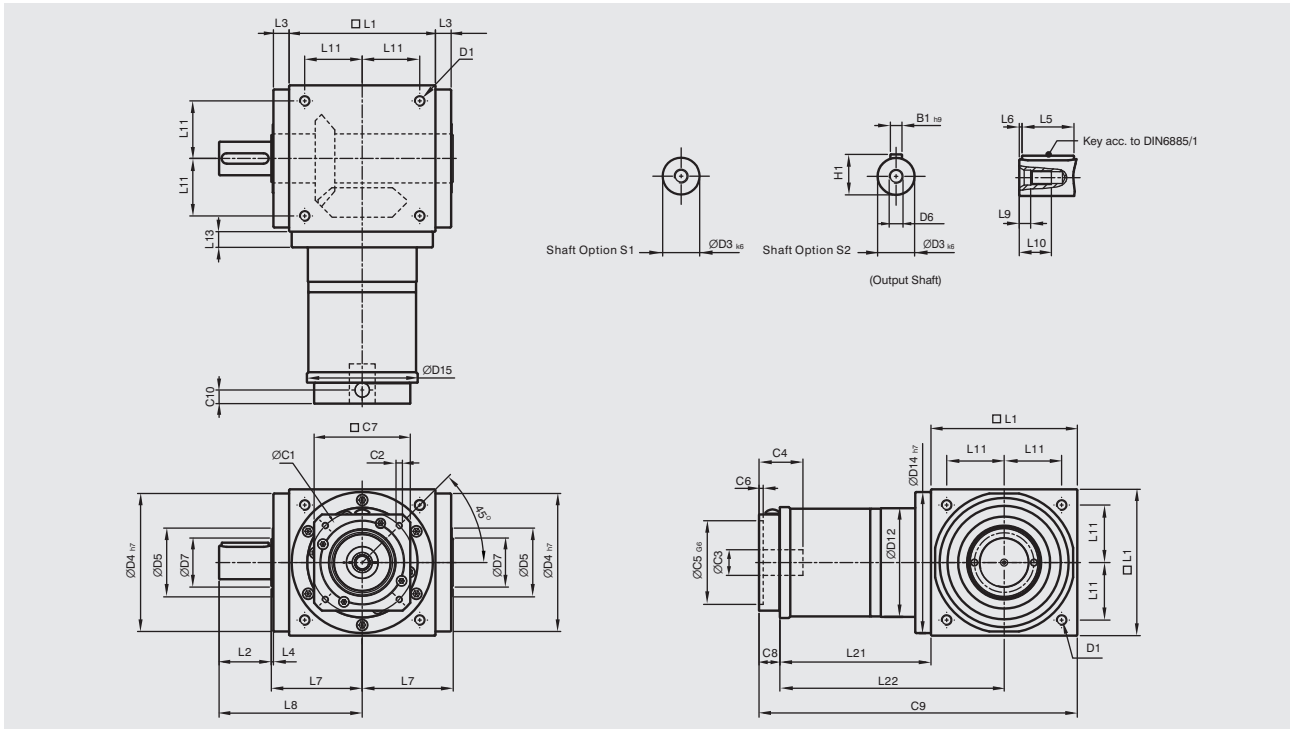

[unit: mm]

Dimension	AT065FL1	AT075FL1	AT090FL1	AT110FL1	AT140FL1	AT170FL1	AT210FL1	AT240FL1	AT280FL1
D1	M4	M6	M6	M8	M10	M12	M16	M16	M16
D3 _{k6}	13	16	18	22	32	40	50	55	60
D4 _{h7}	63	73	88	108	135	165	205	235	275
D5	31	35	43	53	68	83	104	124	144
D6	M4	M5	M5	M8	M12	M16	M16	M16	M20
D7	21	22	28	33	47	55	75	85	110
D12	62	72	86	106	104	128	160	180	200
D14 _{h7}	63	73	88	108	135	165	205	235	275
D15	62.9	72.9	87	107	106	127	158	178	198
L1	65	75	90	110	140	170	210	240	280
L2	19.5	30	35	40	50	60	75	85	110
L3	13	14.5	15	15	15	15	20	25	25
L4	2	2	2	2	2	2	2	2	2
L5	16	25	28	32	45	50	70	80	100
L6	2	2.5	3.5	4	2.5	5	2.5	2.5	5
L7	47.5	54	62	72	87	102	127	147	167
L8	67	84	97	112	137	162	202	232	277
L9	4.5	4.8	4.8	7.2	10	12	12	12	15
L10	10	12.5	12.5	19	28	36	36	36	42
L11	27	30	36	44	55	67	85	95	110
L13	13	15	15	15	15	15	20	25	25
L21	75	84.5	99	122	144.5	157.5	206.5	239	248
L22	107.5	122	144	177	214.5	242.5	311.5	359	388
C1 ⁷	46	46	70	100	100	100	130	165	165
C2 ⁷	M4	M4	M5	M6	M6	M6	M8	M10	M10
C3 ⁷	≤12	≤12	≤16	≤24	≤24	≤24	≤32	≤38	≤38
C4 ⁷	30	30	34	40	40	40	50	60	60
C5 ⁷ _{G6}	30	30	50	80	80	80	110	130	130
C6 ⁷	3.5	3.5	8	4	4	4	5	6	6
C7 ⁷	42	42	60	92	92	92	115	142	142
C8 ⁷	21.5	21.5	21.5	20	20	20	24	31	31
C9 ⁷	161.5	181	210.5	252	304.5	347.5	440.5	510	559
C10 ⁷	14.55	14.5	15.5	13	13	13	16	21	21
B1 _{h9}	5	5	6	6	10	12	14	16	18
H1	15	18	20.5	24.5	35	43	53.5	59	64

7. C1~C10 are motor specific dimensions (metric std shown). Refer to Apexdyna.com and Design Tool to view your specific motor mounting system.

AT-FL1 Series

Dimensions (3-stage, Ratio $i=75\sim 500$)

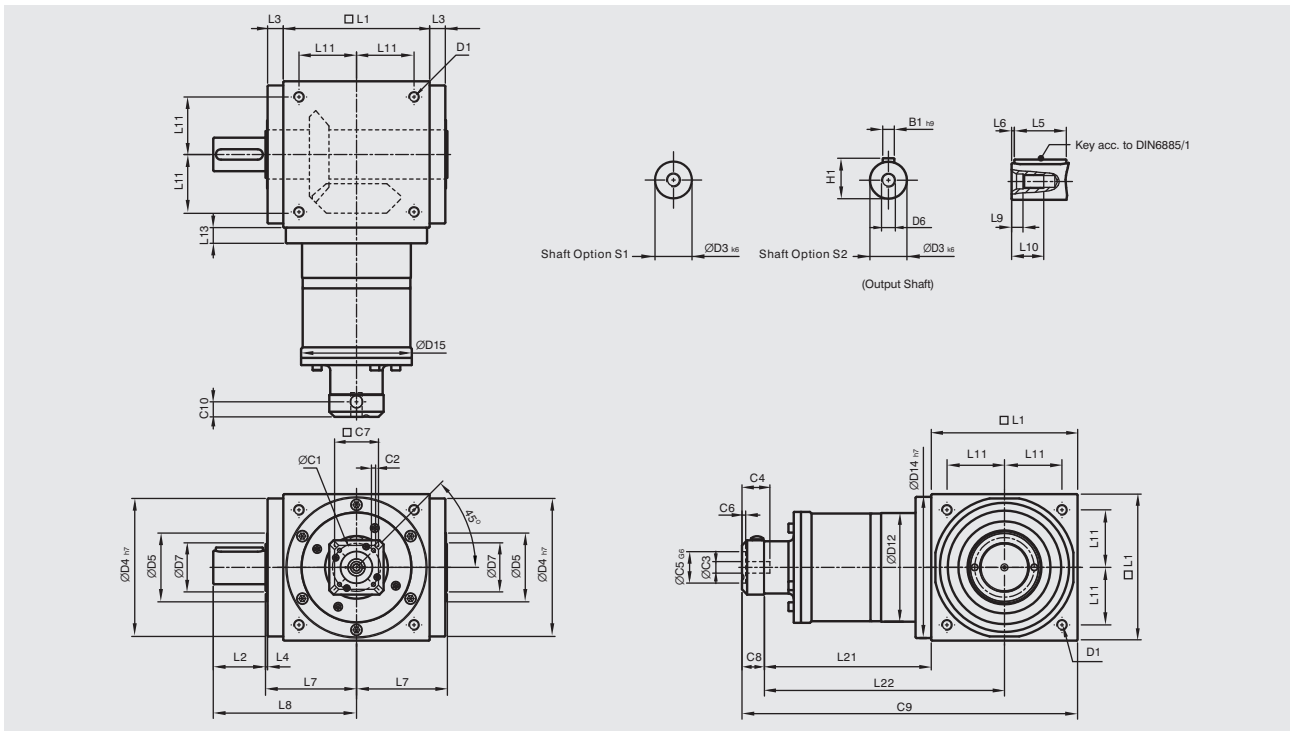

[unit: mm]

Dimension	AT110FL1	AT140FL1	AT170FL1	AT210FL1	AT240FL1	AT280FL1
D1	M8	M10	M12	M16	M16	M16
D3 k6	22	32	40	50	55	60
D4 h7	108	135	165	205	235	275
D5	53	68	83	104	124	144
D6	M8	M12	M16	M16	M16	M20
D7	33	47	55	75	85	110
D12	106	104	128	160	180	200
D14 h7	108	135	165	205	235	275
D15	107	106	127	158	178	198
L1	110	140	170	210	240	280
L2	40	50	60	75	85	110
L3	15	15	15	20	25	25
L4	2	2	2	2	2	2
L5	32	45	50	70	80	100
L6	4	2.5	5	2.5	2.5	5
L7	72	87	102	127	147	167
L8	112	137	162	202	232	277
L9	7.2	10	12	12	12	15
L10	19	28	36	36	36	42
L11	44	55	67	85	95	110
L13	15	15	15	20	25	25
L21	136.5	159.5	183.5	226	269	278
L22	191.5	229.5	268.5	331	389	418
C1 ⁸	46	46	70	70	100	100
C2 ⁸	M4	M4	M5	M5	M6	M6
C3 ⁸	≤12	≤12	≤16	≤16	≤24	≤24
C4 ⁸	30	30	34	34	40	40
C5 ⁸ G6	30	30	50	50	80	80
C6 ⁸	3.5	3.5	8	8	4	4
C7 ⁸	42	42	60	60	92	92
C8 ⁸	21.5	21.5	21.5	21.5	20	20
C9 ⁸	268	321	375	457.5	529	578
C10 ⁸	14.5	14.5	15.5	15.5	13	13
B1 h9	6	10	12	14	16	18
H1	24.5	35	43	53.5	59	64

8. C1-C10 are motor specific dimensions (metric std shown). Refer to Apexdyna.com and Design Tool to view your specific motor mounting system.

AT-FH Series

Dimensions (1-stage, Ratio i=1~5)

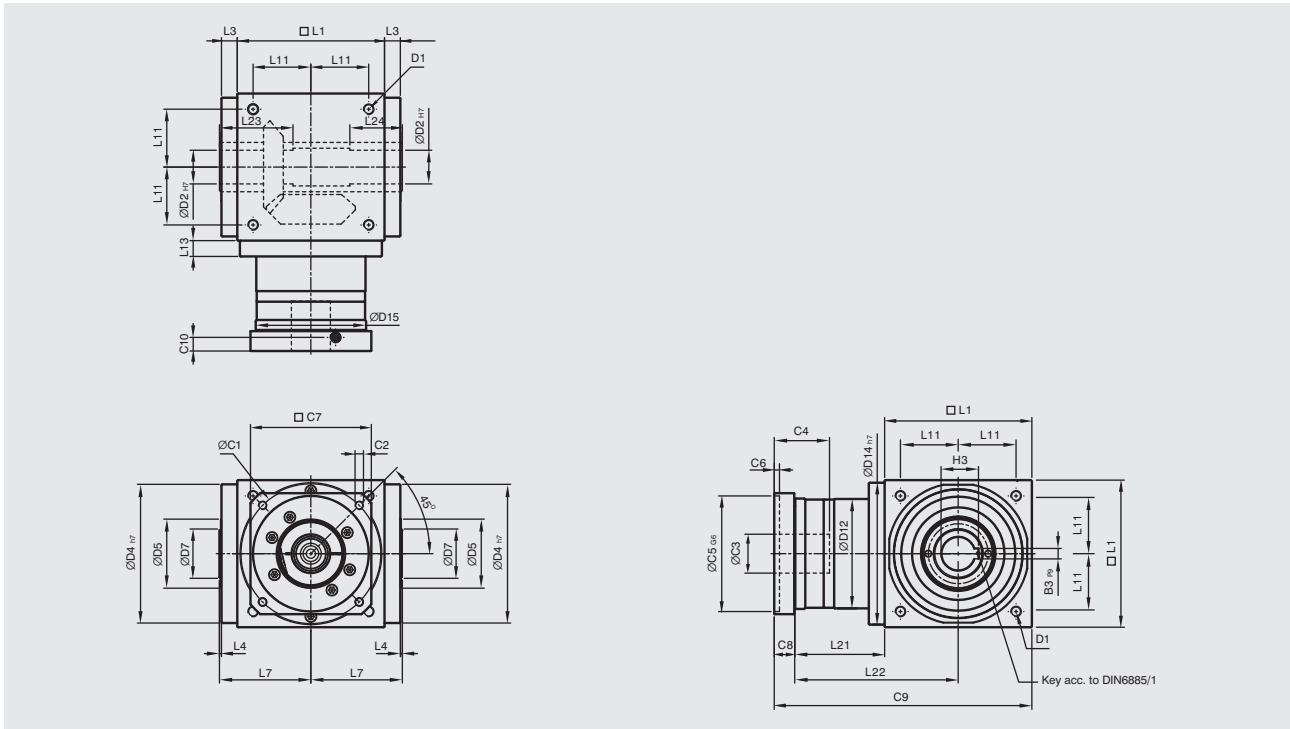

[unit: mm]

Dimension	AT065FH	AT075FH	AT090FH	AT110FH	AT140FH	AT170FH	AT210FH	AT240FH	AT280FH
D1	M4	M6	M6	M8	M10	M12	M16	M16	M16
D2 _{H7}	13	14	18	22	32	40	50	55	60
D4 _{H7}	63	73	88	108	135	165	205	235	275
D5	31	35	43	53	68	83	104	124	144
D7	21	22	28	33	47	55	75	85	110
D12	62	72	86	106	104	128	160	180	200
D14 _{H7}	63	73	88	108	135	165	205	235	275
D15	62.9	72.9	87	107	105	127	158	178	198
L1	65	75	90	110	140	170	210	240	280
L3	13	14.5	15	15	15	15	20	25	25
L4	2	2	2	2	2	2	2	2	2
L7	47.5	54	62	72	87	102	127	147	167
L11	27	30	36	44	55	67	85	95	110
L13	13	15	15	15	15	15	20	25	25
L21	49	60.5	63	69.5	85.5	95	130	144.5	135
L22	81.5	98	108	124.5	155.5	180	235	264.5	275
L23	40	47	52	53	70	80	95	115	115
L24	30	32	35	35	50	55	65	80	80
C1 ⁹	46	70	100	100	130	165	215	215	235
C2 ⁹	M4	M5	M6	M6	M8	M10	M12	M12	M12
C3 ⁹	★ ≤11 / ≤12	★ ≤14 / ≤15.875 / ≤16	≤19	≤24	≤32	≤38	≤42	≤48	≤55
C4 ⁹	30	34	40	40	50	60	85	85	116
C5 ⁹ _{G6}	30	50	80	80	110	130	180	180	200
C6 ⁹	3.5	8	4	4	5	6	6	6	6
C7 ⁹	42	60	90	90	115	142	190	190	220
C8 ⁹	19.5	19	17	17	19.5	22.5	29	29	63
C9 ⁹	133.5	154.5	170	196.5	245	287.5	369	413.5	478
C10 ⁹	13.25	13.5	10.75	10.75	13	15	20.75	20.75	53.5
B3 _{P9}	5	5	6	6	10	12	14	16	18
H3	15.3	16.3	20.8	24.8	35.3	43.3	53.8	59.3	64.4

9. C1~C10 are motor specific dimensions (metric std shown). Refer to Apexdyna.com and Design Tool to view your specific motor mounting system.

★ AT065FHM1 offers C3 ≤12 option. ★ AT075FHM1 offers C3 ≤16 option. ★ AT075FHM2 offers C3 ≤15.875 option.

AT-FH Series

Dimensions (2-stage, Ratio $i=7\sim 50$)

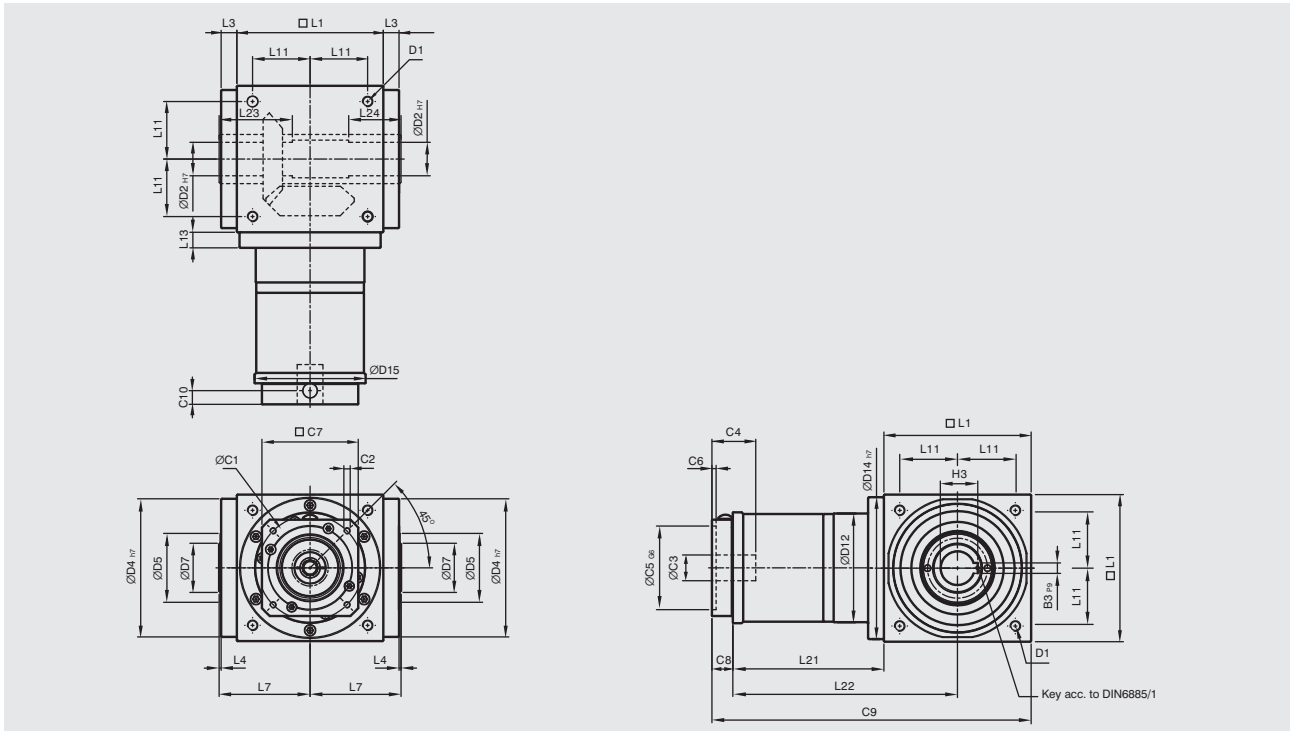

[unit: mm]

Dimension	AT065FH	AT075FH	AT090FH	AT110FH	AT140FH	AT170FH	AT210FH	AT240FH	AT280FH
D1	M4	M6	M6	M8	M10	M12	M16	M16	M16
D2 _{H7}	13	14	18	22	32	40	50	55	60
D4 _{H7}	63	73	88	108	135	165	205	235	275
D5	31	35	43	53	68	83	104	124	144
D7	21	22	28	33	47	55	75	85	110
D12	62	72	86	106	104	128	160	180	200
D14 _{H7}	63	73	88	108	135	165	205	235	275
D15	62.9	72.9	87	107	106	127	158	178	198
L1	65	75	90	110	140	170	210	240	280
L3	13	14.5	15	15	15	15	20	25	25
L4	2	2	2	2	2	2	2	2	2
L7	47.5	54	62	72	87	102	127	147	167
L11	27	30	36	44	55	67	85	95	110
L13	13	15	15	15	15	15	20	25	25
L21	75	84.5	99	122	144.5	157.5	206.5	239	248
L22	107.5	122	144	177	214.5	242.5	311.5	359	388
L23	40	47	52	53	70	80	95	115	115
L24	30	32	35	35	50	55	65	80	80
C1 ¹⁰	46	46	70	100	100	100	130	165	165
C2 ¹⁰	M4	M4	M5	M6	M6	M6	M8	M10	M10
C3 ¹⁰	≤12	≤12	≤16	≤24	≤24	≤24	≤32	≤38	≤38
C4 ¹⁰	30	30	34	40	40	40	50	60	60
C5 ¹⁰ _{G6}	30	30	50	80	80	80	110	130	130
C6 ¹⁰	3.5	3.5	8	4	4	4	5	6	6
C7 ¹⁰	42	42	60	92	92	92	115	142	142
C8 ¹⁰	21.5	21.5	21.5	20	20	20	24	31	31
C9 ¹⁰	161.5	181	210.5	252	304.5	347.5	440.5	510	559
C10 ¹⁰	14.5	14.5	15.5	13	13	13	16	21	21
B3 _{P9}	5	5	6	6	10	12	14	16	18
H3	15.3	16.3	20.8	24.8	35.3	43.3	53.8	59.3	64.4

10. C1~C10 are motor specific dimensions (metric std shown). Refer to Apexdyna.com and Design Tool to view your specific motor mounting system.

AT-FH Series

Dimensions (3-stage, Ratio $i=75\sim 500$)

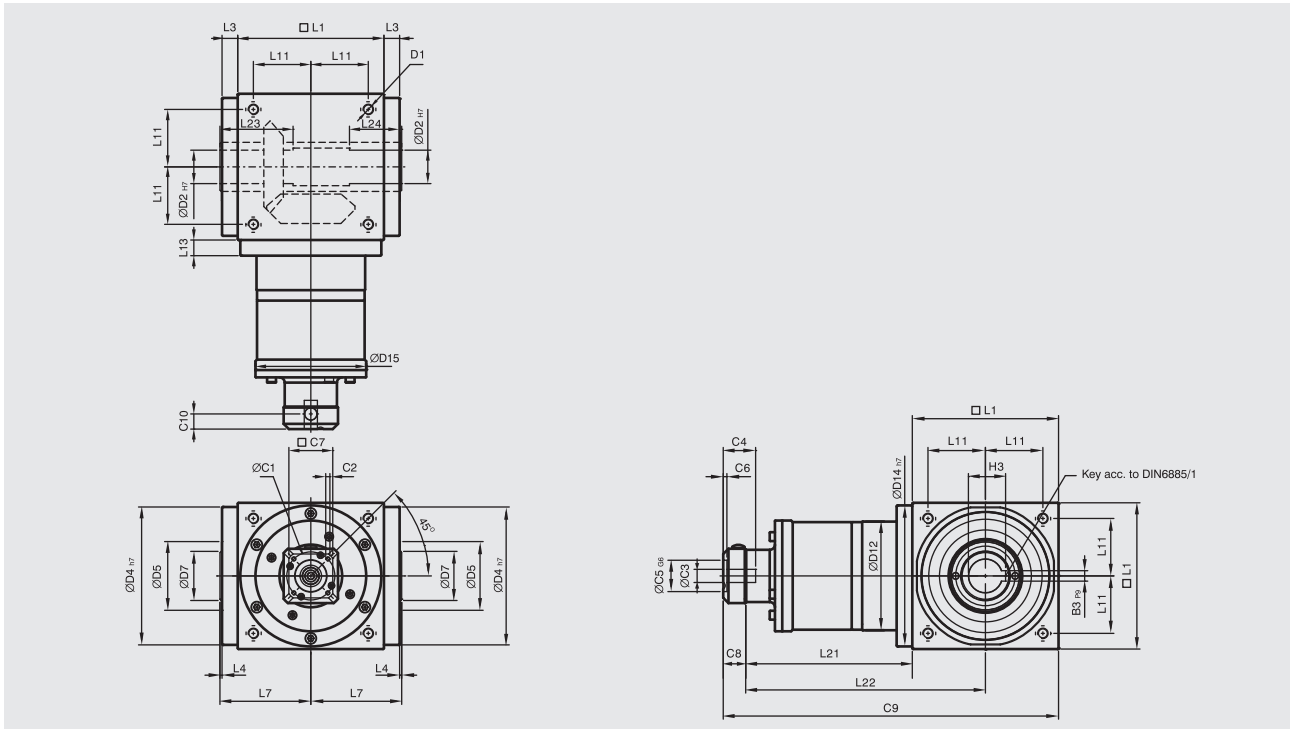

[unit: mm]

Dimension	AT110FH	AT140FH	AT170FH	AT210FH	AT240FH	AT280FH
D1	M8	M10	M12	M16	M16	M16
D2 _{H7}	22	32	40	50	55	60
D4 _{H7}	108	135	165	205	235	275
D5	53	68	83	104	124	144
D7	33	47	55	75	85	110
D12	106	104	128	160	180	200
D14 _{H7}	108	135	165	205	235	275
D15	107	106	127	158	178	198
L1	110	140	170	210	240	280
L3	15	15	15	20	25	25
L4	2	2	2	2	2	2
L7	72	87	102	127	147	167
L11	44	55	67	85	95	110
L13	15	15	15	20	25	25
L21	136.5	159.5	183.5	226	269	278
L22	191.5	229.5	268.5	331	389	418
L23	53	70	80	95	115	115
L24	35	50	55	65	80	80
C1 ¹¹	46	46	70	70	100	100
C2 ¹¹	M4	M4	M5	M5	M6	M6
C3 ¹¹	≤12	≤12	≤16	≤16	≤24	≤24
C4 ¹¹	30	30	34	34	40	40
C5 ¹¹ _{G6}	30	30	50	50	80	80
C6 ¹¹	3.5	3.5	8	8	4	4
C7 ¹¹	42	42	60	60	92	92
C8 ¹¹	21.5	21.5	21.5	21.5	20	20
C9 ¹¹	268	321	375	457.5	529	578
C10 ¹¹	14.5	14.5	15.5	15.5	13	13
B3 _{P9}	6	10	12	14	16	18
H3	24.8	35.3	43.3	53.8	59.3	64.4

11. C1-C10 are motor specific dimensions (metric std shown). Refer to Apexdyna.com and Design Tool to view your specific motor mounting system.

AT-FC Series

Dimensions (1-stage, Ratio $i=1\sim5$)

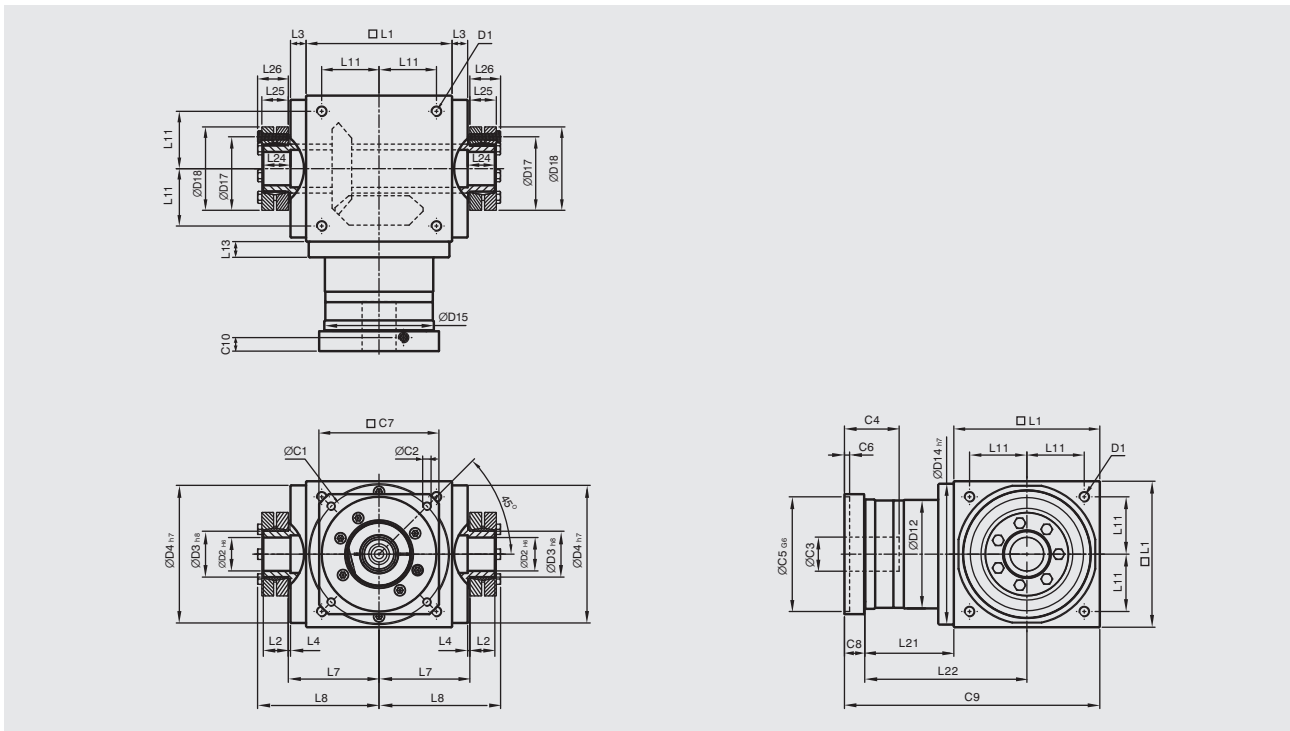

● Standard accessory includes 2 shrink disk power lock units.

[unit: mm]

Dimension	AT065FC	AT075FC	AT090FC	AT110FC	AT140FC	AT170FC	AT210FC	AT240FC	AT280FC
D1	M4	M6	M6	M8	M10	M12	M16	M16	M16
D2 H6	13	14	18	22	32	40	50	55	60
D3 h8	16	16	22	25	44	50	62	68	75
D4 h7	63	73	88	108	135	165	205	235	275
D12	62	72	86	106	104	128	160	180	200
D14 h7	63	73	88	108	135	165	205	235	275
D15	62.9	72.9	87	107	105	130	158	178	198
D17	26	26	36	38	61	70	86	86	100
D18	41	41	50	50	80	90	110	115	138
L1	65	75	90	110	140	170	210	240	280
L2	14	14	18	18	24	26	29	29	30.5
L3	13	14.5	15	15	15	15	20	25	25
L4	2	2	2	2	2	2	2	2	2
L7	47.5	54	62	72	87	102	127	147	167
L8	66	72.5	85	95	116.5	113.5	161.5	181.5	205
L11	27	30	36	44	55	67	85	95	110
L13	13	15	15	15	15	15	20	25	25
L21	49	60.5	63	69.5	85.5	95	130	144.5	135
L22	81.5	98	108	124.5	155.5	180	235	264.5	275
L23	15	15	20	20	26	28	31	31	32.5
L24	15	15	20	20	26	28	31	31	32.5
L25	15	15	19.5	19.5	25.5	27.5	30.5	30.5	32.5
L26	18.5	18.5	23	23	29.5	31.5	34.5	34.5	38
C1 ¹²	46	70	100	100	130	165	215	215	235
C2 ¹²	M4	M5	M6	M6	M8	M10	M12	M12	M12
C3 ¹²	★ ≤11 / ≤12	★ ≤14 / ≤15.875 / ≤16	≤19	≤24	≤32	≤38	≤42	≤48	≤55
C4 ¹²	30	34	40	40	50	60	85	85	116
C5 ¹² G6	30	50	80	80	110	130	180	180	200
C6 ¹²	3.5	8	4	4	5	6	6	6	6
C7 ¹²	42	60	90	90	115	142	190	190	220
C8 ¹²	19.5	19	17	17	19.5	22.5	29	29	63
C9 ¹²	133.5	154.5	170	196.5	245	287.5	369	413.5	478
C10 ¹²	13.25	13.5	10.75	10.75	13	15	20.75	20.75	53.5

12. C1~C10 are motor specific dimensions (metric std shown). Refer to Apexdyna.com and Design Tool to view your specific motor mounting system.

★ AT065FCM1 offers C3 ≤12 option. ★ AT075FCM1 offers C3 ≤16 option. ★ AT075FCM2 offers C3 ≤15.875 option.

AT-FC Series

Dimensions (2-stage, Ratio $i=7\sim 50$)

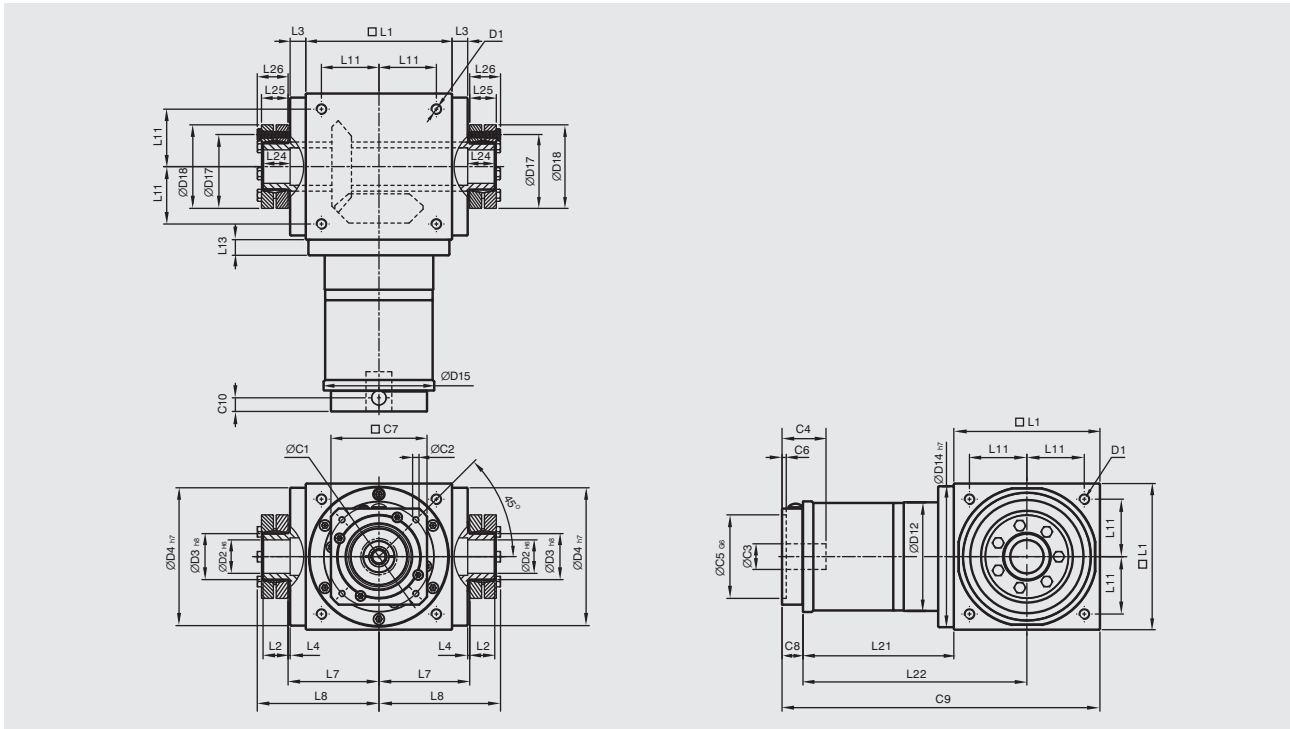

● Standard accessory includes 2 shrink disk power lock units.

[unit: mm]

Dimension	AT065FC	AT075FC	AT090FC	AT110FC	AT140FC	AT170FC	AT210FC	AT240FC	AT280FC
D1	M4	M6	M6	M8	M10	M12	M16	M16	M16
D2 _{H6}	13	14	18	22	32	40	50	55	60
D3 _{h8}	16	16	22	25	44	50	62	68	75
D4 _{h7}	63	73	88	108	135	165	205	235	275
D12	62	72	86	106	104	128	160	180	200
D14 _{h7}	63	73	88	108	135	165	205	235	275
D15	62.9	72.9	87	107	106	127	158	178	198
D17	26	26	36	38	61	70	86	86	100
D18	41	41	50	50	80	90	110	115	138
L1	65	75	90	110	140	170	210	240	280
L2	14	14	18	18	24	26	29	29	30.5
L3	13	14.5	15	15	15	15	20	25	25
L4	2	2	2	2	2	2	2	2	2
L7	47.5	54	62	72	87	102	127	147	167
L8	66	72.5	85	95	116.5	133.5	161.5	181.5	205
L11	27	30	36	44	55	67	85	95	110
L13	13	15	15	15	15	15	20	25	25
L21	75	84.5	99	122	144.5	157.5	206.5	239	248
L22	107.5	122	144	177	214.5	242.5	311.5	359	388
L23	15	15	20	20	26	28	31	31	32.5
L24	15	15	20	20	26	28	31	31	32.5
L25	15	15	19.5	19.5	25.5	27.5	30.5	30.5	32.5
L26	18.5	18.5	23	23	29.5	31.5	34.5	34.5	38
C1 ¹³	46	46	70	100	100	100	130	165	165
C2 ¹³	M4	M4	M5	M6	M6	M6	M8	M10	M10
C3 ¹³	≤12	≤12	≤16	≤24	≤24	≤24	≤32	≤38	≤38
C4 ¹³	30	30	34	40	40	40	50	60	60
C5 ¹³ _{G6}	30	30	50	80	80	80	110	130	130
C6 ¹³	3.5	3.5	8	4	4	4	5	6	6
C7 ¹³	42	42	60	92	92	92	115	142	142
C8 ¹³	21.5	21.5	21.5	20	20	20	24	31	31
C9 ¹³	161.5	181	210.5	252	304.5	347.5	440.5	510	559
C10 ¹³	14.5	14.5	15.5	13	13	13	16	21	21

13. C1-C10 are motor specific dimensions (metric std shown). Refer to Apexdyna.com and Design Tool to view your specific motor mounting system.

AT-FC Series

Dimensions (3-stage, Ratio $i=75\sim 500$)

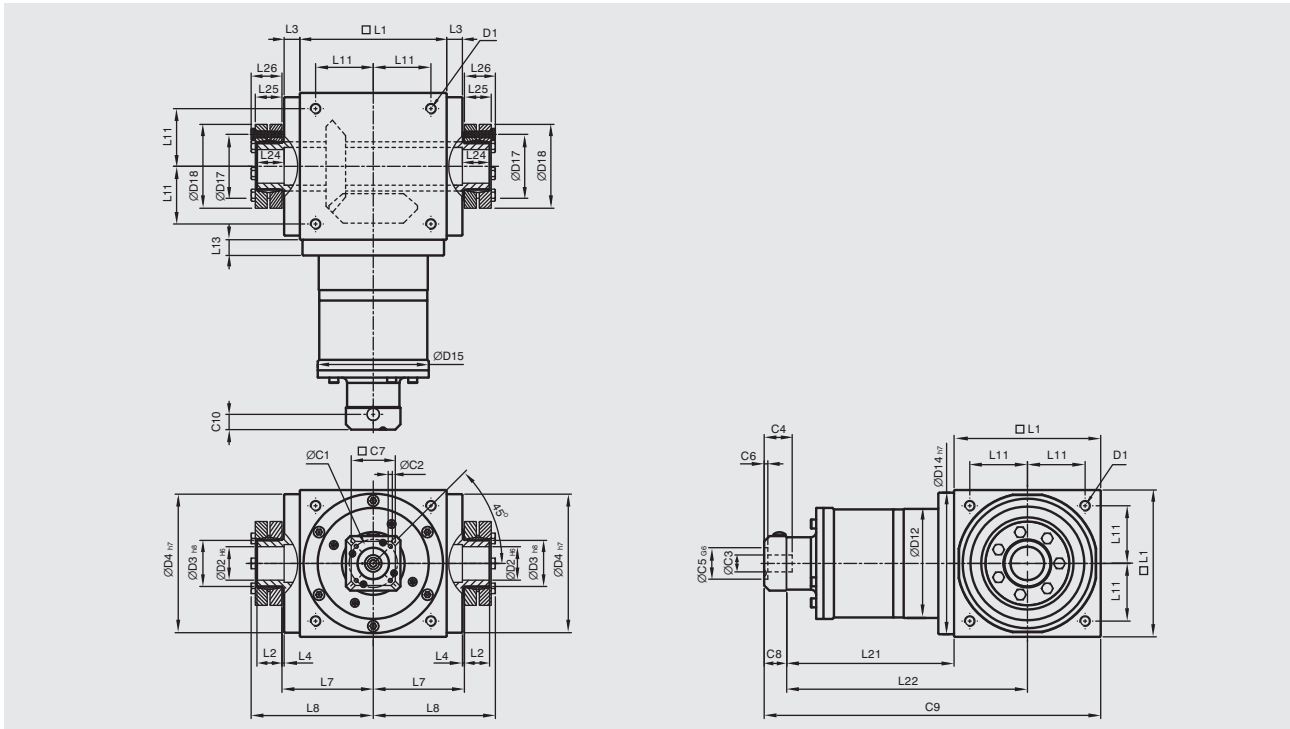

● Standard accessory includes 2 shrink disk power lock units.

[unit: mm]

Dimension	AT110FC	AT140FC	AT170FC	AT210FC	AT240FC	AT280FC
D1	M8	M10	M12	M16	M16	M16
D2 H6	22	32	40	50	55	60
D3 h8	25	44	50	62	68	75
D4 h7	108	135	165	205	235	275
D12	106	104	128	160	180	200
D14 h7	108	135	165	205	235	275
D15	107	106	127	158	178	198
D17	38	61	70	86	86	100
D18	50	80	90	110	115	138
L1	110	140	170	210	240	280
L2	18	24	26	29	29	30.5
L3	15	15	15	20	25	25
L4	2	2	2	2	2	2
L7	72	87	102	127	147	167
L8	95	116.5	133.5	161.5	181.5	205
L11	44	55	67	85	95	110
L13	15	15	15	20	25	25
L21	136.5	159.5	183.5	226	269	278
L22	191.5	229.5	268.5	331	389	418
L23	20	26	28	31	31	32.5
L24	20	26	28	31	31	32.5
L25	19.5	25.5	27.5	30.5	30.5	32.5
L26	23	29.5	31.5	34.5	34.5	38
C1 ¹⁴	46	46	70	70	100	100
C2 ¹⁴	M4	M4	M5	M5	M6	M6
C3 ¹⁴	≤12	≤12	≤16	≤16	≤24	≤24
C4 ¹⁴	30	30	34	34	40	40
C5 ¹⁴ G6	30	30	50	50	80	80
C6 ¹⁴	3.5	3.5	8	8	4	4
C7 ¹⁴	42	42	60	60	92	92
C8 ¹⁴	21.5	21.5	21.5	21.5	20	20
C9 ¹⁴	268	321	375	457.5	529	578
C10 ¹⁴	14.5	14.5	15.5	15.5	13	13

14. C1~C10 are motor specific dimensions (metric std shown). Refer to Apexdyna.com and Design Tool to view your specific motor mounting system.

Shrink Disc Power Lock

[unit: mm]

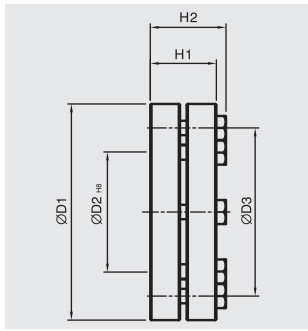

C / FC Series	D1	D2	D3	H1	H2
SSD-d16xdw14	41	16	26	15	18.5
SSD-d22xdw18	50	22	36	19.5	23
SSD-d25xdw22	50	25	38	19.5	23
SSD-d44xdw32	80	44	61	25.5	29.5
SSD-d50xdw40	90	50	70	27.5	31.5
SSD-d62xdw50	110	62	86	30.5	34.5
SSD-d68xdw55	115	68	86	30.5	34.5
SSD-d75xdw60	138	75	100	32.5	38

Selection of the Optimum Gearbox

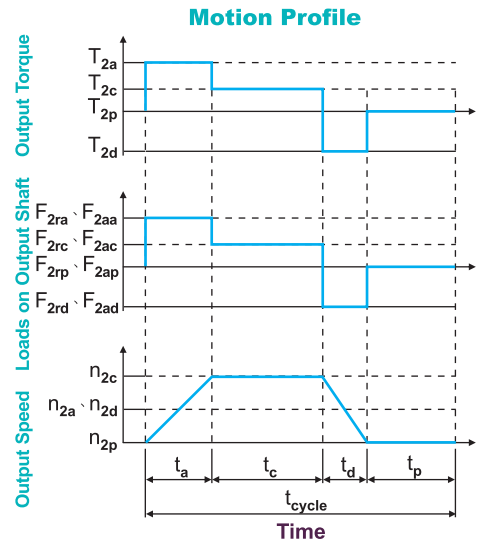
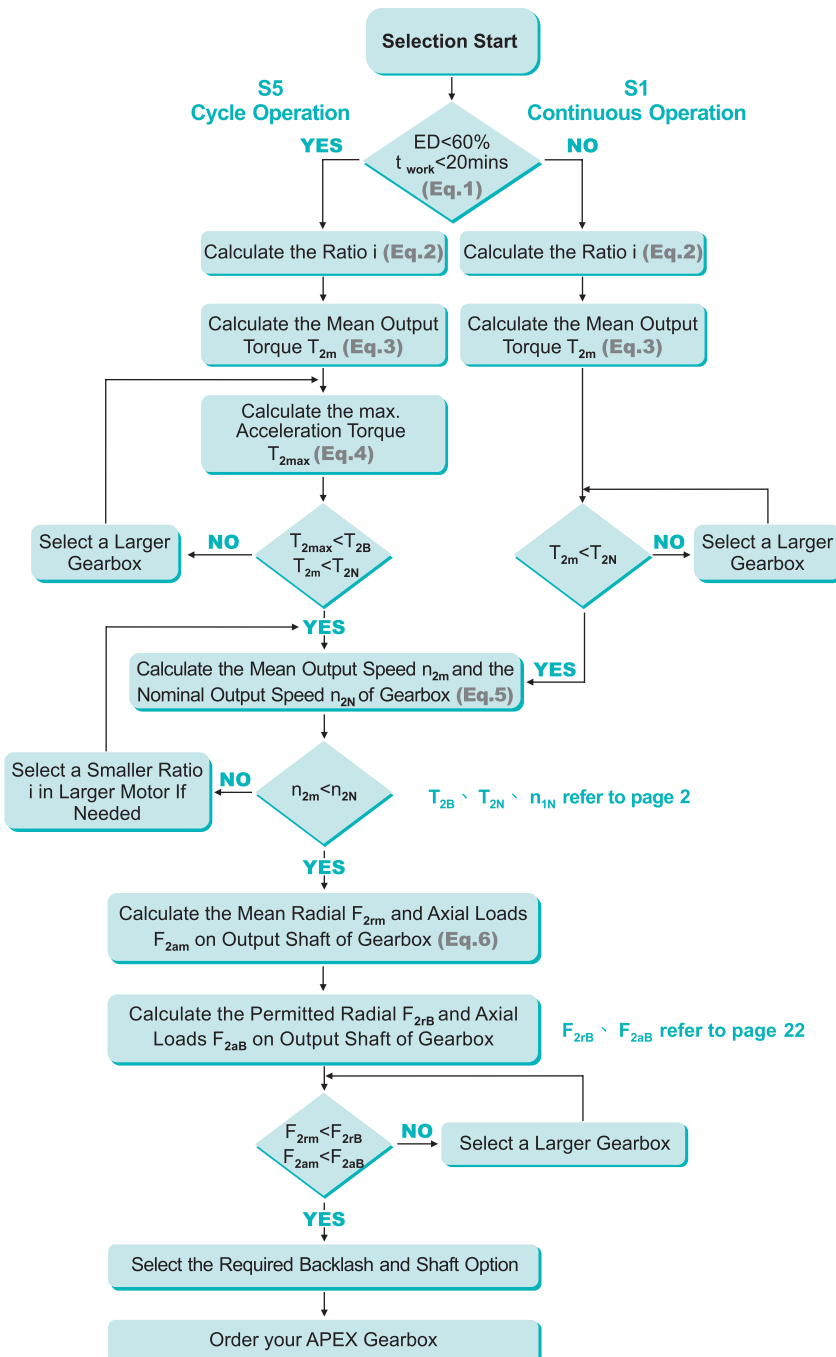

$$1. ED = \frac{t_a + t_c + t_d}{t_{\text{cycle}}} \times 100\%, t_{\text{work}} = t_a + t_c + t_d$$

Index : a. Acceleration, c. Constant, d. Deceleration, p. Pause (Eq.1)

$$2. i \cong \frac{n_m}{n_{\text{work}}}$$

n_m Output Speed of the Motor (Eq.2)

n_{work} Working Speed

$$3. T_{2m} = \sqrt[3]{\frac{n_{2a}^3 \times t_a + n_{2c}^3 \times t_c + n_{2d}^3 \times t_d}{n_{2a} \times t_a + n_{2c} \times t_c + n_{2d} \times t_d}}$$

$$4. T_{2max} = T_{mB} \times i \times k_s \times \eta$$

where k_s is

k_s	No. of Cycles / hr
1.0	0~1,000
1.1	1,000 ~ 1,500
1.3	1,500 ~ 2,000
1.6	2,000 ~ 3,000
1.8	3,000 ~ 5,000
2.0	5,000 ~ 9,000
2.05	9,000 ~ 10,000
not recommended	above 10,000

Recommended (for S5 Cycle Operation)

The general design is given for

$$\frac{J_L}{i^2} \leq 4 \times J_m$$

The optimal design is given for

$$\frac{J_L}{i^2} \cong J_m$$

J_L Load Inertia

J_m Motor Inertia

T_{mB} Max. Output Torque of the Motor

η Efficiency of the Gearbox

(Eq.4)

$$5. n_{2a} = n_{2d} = \frac{1}{2} \times n_{2c}$$

$$n_{2m} = \frac{n_{2a} \times t_a + n_{2c} \times t_c + n_{2d} \times t_d}{t_a + t_c + t_d}$$

$$n_{2N} = \frac{n_{1N}}{i}$$

(Eq.5)

$$6. F_{2rm} = \sqrt[3]{\frac{n_{2a} \times t_a \times F_{2ra}^3 + n_{2c} \times t_c \times F_{2rc}^3 + n_{2d} \times t_d \times F_{2rd}^3}{n_{2a} \times t_a + n_{2c} \times t_c + n_{2d} \times t_d}}$$

$$F_{2am} = \sqrt[3]{\frac{n_{2a} \times t_a \times F_{2aa}^3 + n_{2c} \times t_c \times F_{2ac}^3 + n_{2d} \times t_d \times F_{2ad}^3}{n_{2a} \times t_a + n_{2c} \times t_c + n_{2d} \times t_d}}$$

(Eq.6)

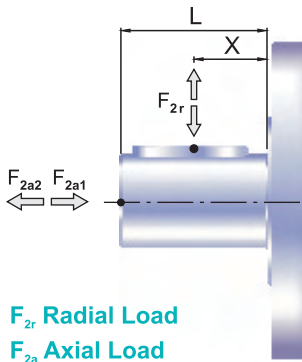

Permitted Radial and Axial Loads on Input and Output Shaft of the Gearbox

The permitted radial and axial loads on output shaft of the gearbox depend on the design of the gearbox supporting bearings.

APEX use the extension straddle oversized Tapered Roller bearing design.

It can take heavy loads from both axes.

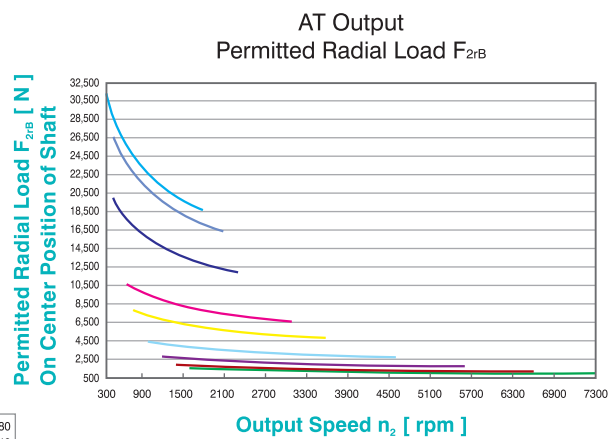
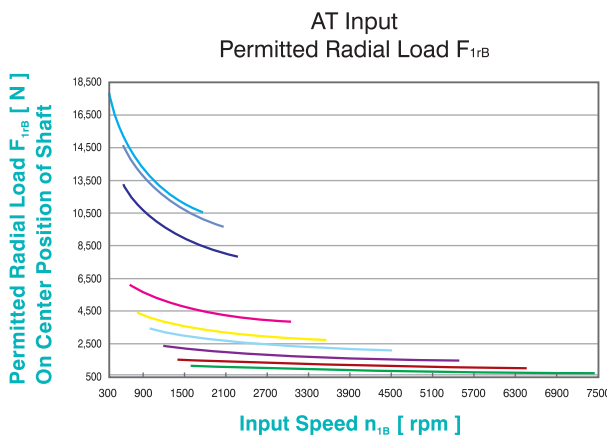

If radial force F_{2r} is exert on the center of the output shaft $X = 1/2 \times L$. Under various operating condition the lifetime is over 30,000 hours. The permitted radial load is given on left diagram.

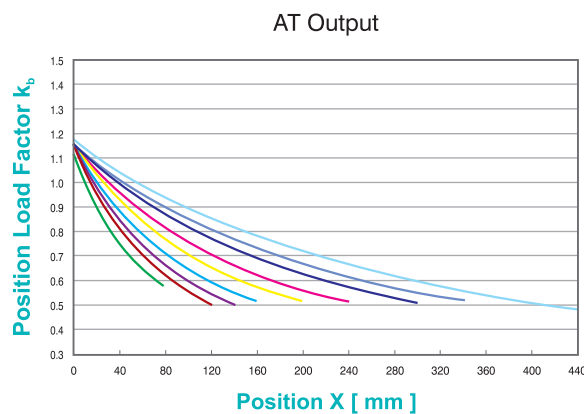
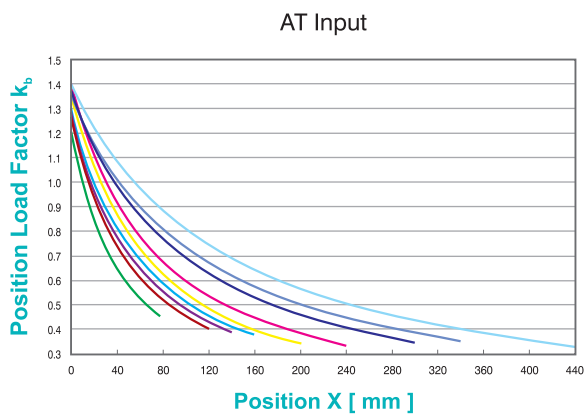

If radial force F_{2r} is not exert on the center of the output shaft $X < 1/2 \times L$ or $X > 1/2 \times L$. The permitted radial and axial loads can be calculated by the position load factor k_b on the left diagram.

AT Series

Ordering Code

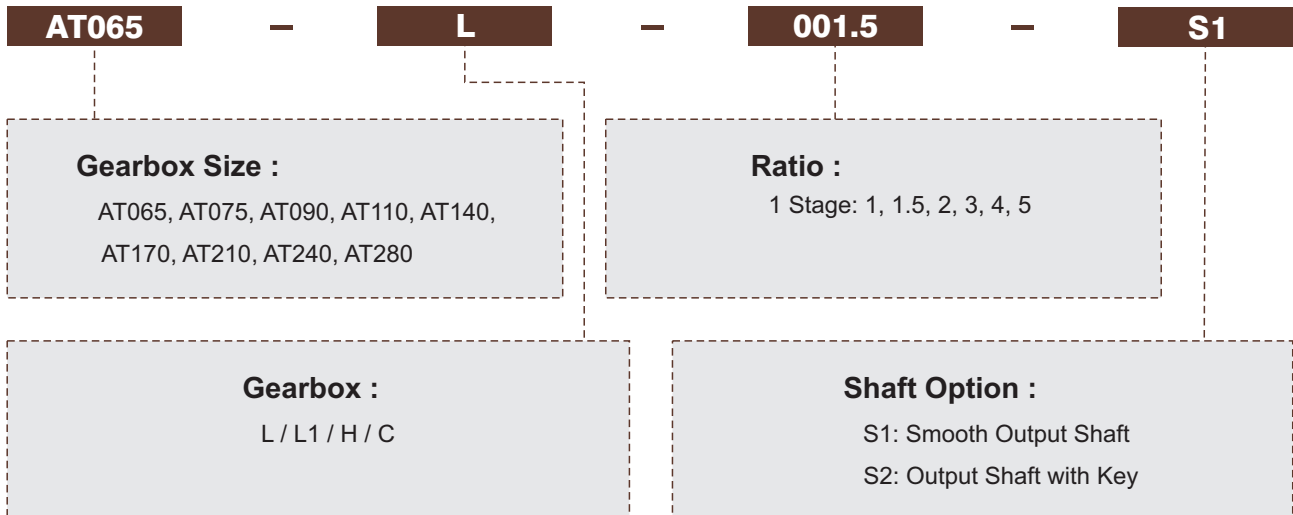

Ordering Example: AT065-L-001.5-S1

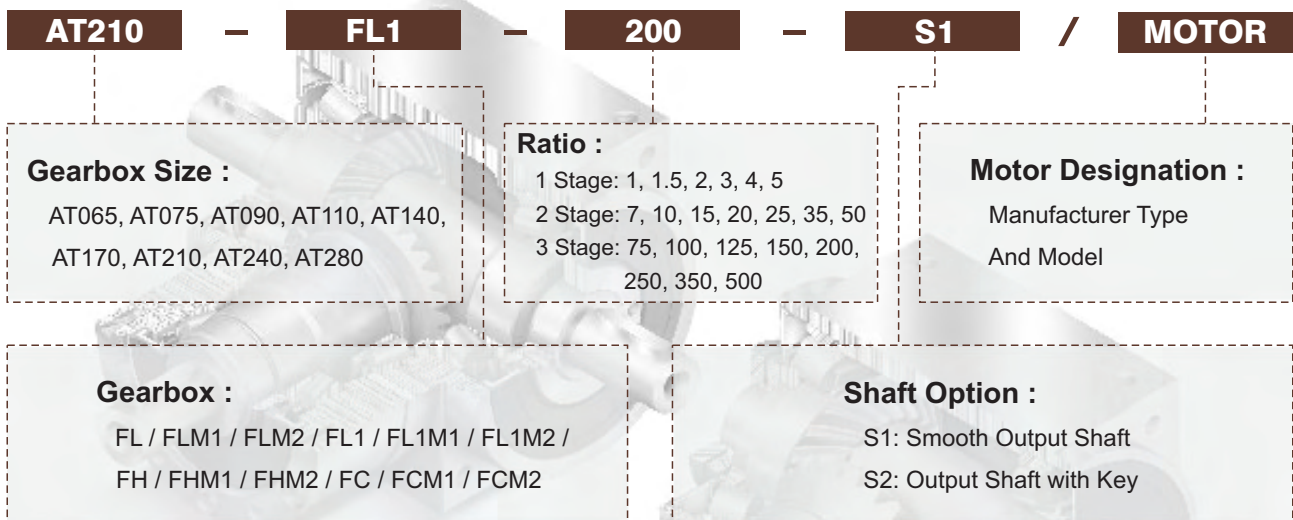

Ordering Example: AT210-FL1-200-S1 / SIEMENS 1FK6 032-6AK71



APEX DYNAMICS, INC.

No.10, Keyuan 3rd Rd., Situn District, Taichung City 407, Taiwan (R.O.C.)

Tel: 886 4 23550219 / Fax: 886 4 23550218

E-mail: sales@apexdyna.com

Website: www.apexdyna.com

