

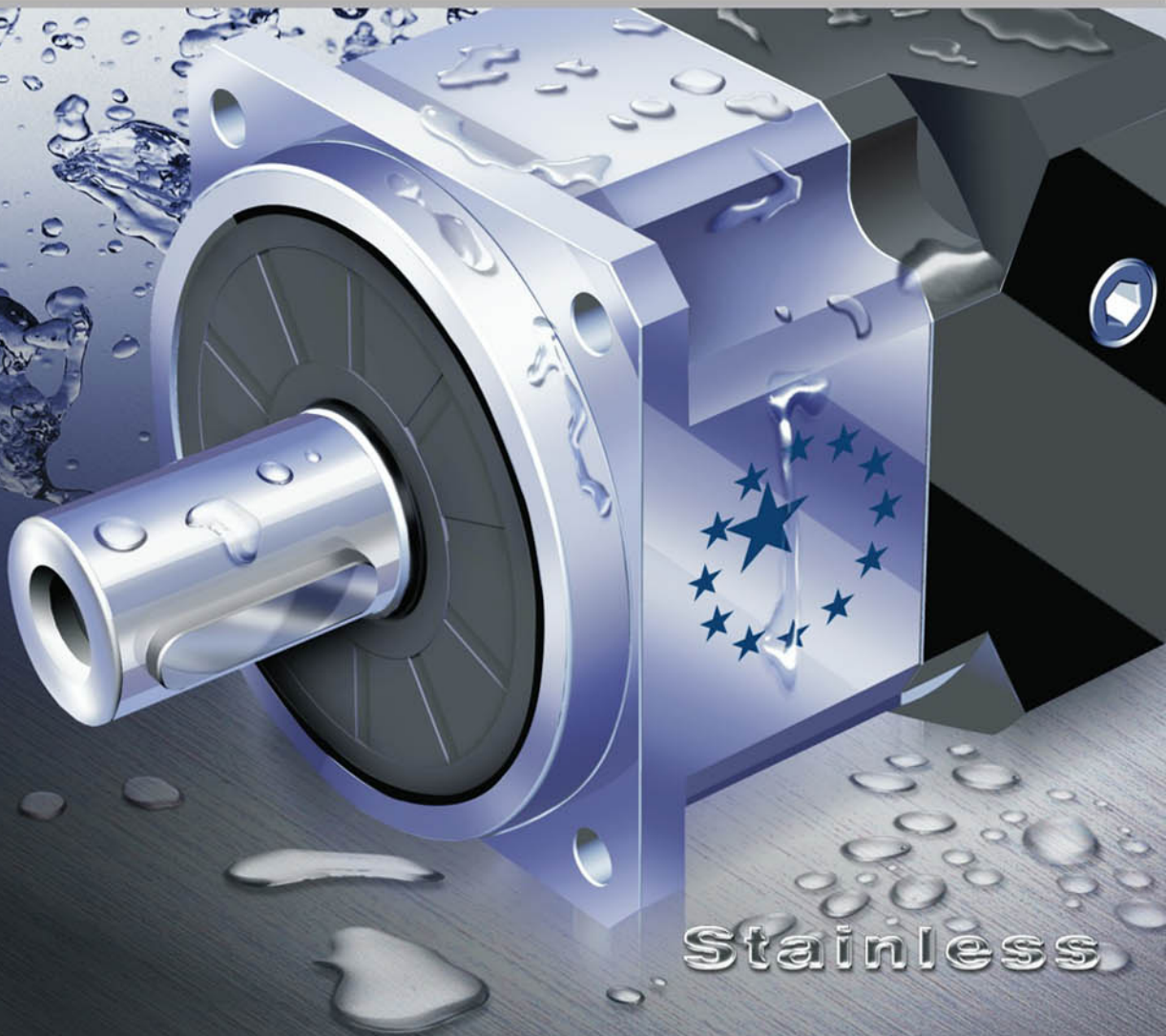

APEX DYNAMICS, INC.

AB Series

High Precision Planetary Gearboxes



Stainless



Characteristic Highlights



Equipped with **solid uncaged needle roller bearings**, provides maximum contact points to increase stiffness and generates high output torque.

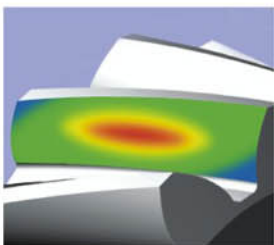

A high setting gear performance is achieved by using our **Helitopo technology**. This **eases off the tooth profile and crowns the lead of each tooth**. This optimizes the gear mesh alignment and overlap to achieve maximum tooth surface contact.

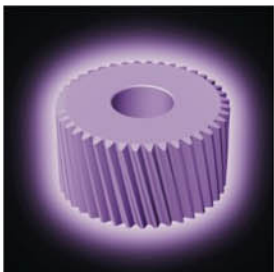

Our **in house plasma nitriding** heat treatment process maintains the tooth surface hardness at **840Hv** for superior wear-resistance and a core hardness at **30 HRC** for toughness.



One piece planet carrier with extended bearing design provides maximum radial load capacity and increases system reliability and stiffness.



True Helical Gear Design
Precision helical gearing increases tooth to tooth contact ratio by over 33% vs spur gearing. The helix angle produces smooth and quiet operation with decreased backlash (less than 1 arc-minutes and $\leq 56\text{dB}$).



Patented planet carrier design puts the sun gear bearing directly into the planet carrier. It minimizes gear misalignment to gain higher accuracy.



Triple split collet with dynamic balanced set collar clamping system provides backlash free power transmission and eliminates slippage. 100% concentricity allows for smooth rotation and higher input speed capability.

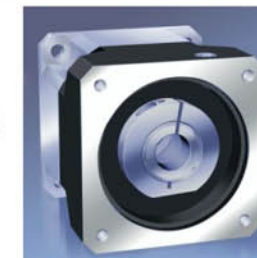

The unique **motor adapter and bushing module system design** allows for quick and easy mounting of any motor.

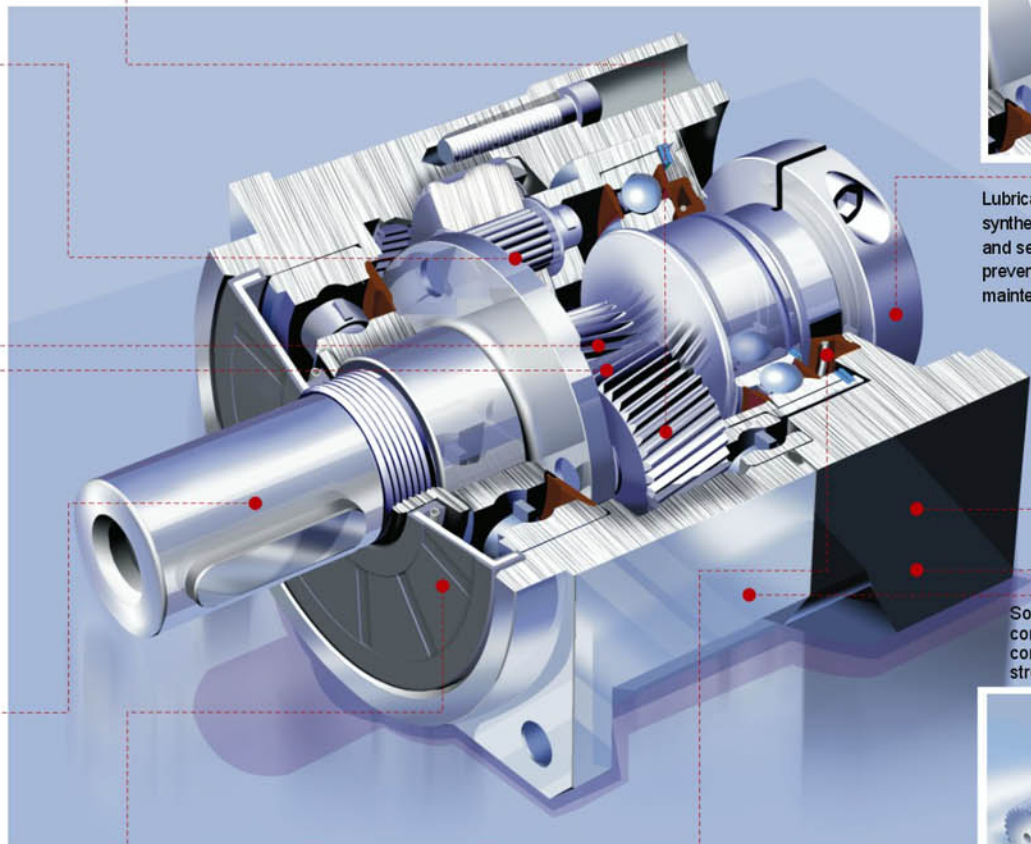

Lubricated with **Nyogel 792D** synthetic grease (Smart Grease) and sealed to **IP65** standards prevents leakage and is maintenance free.

Solid, single piece sun gear construction obtains precise concentricity with increased strength and rigidity.



A special non-electrolysis nickel surface treatment on the output housing and **black anodized** aluminum input adapter are provided for the most extreme environmental conditions.



NEW - Patented output sealing systems design eliminates friction and heat generation which is accomplished by applying our hi-tech coating to all output contact surfaces. This coating reaches a hardness of **3700Hv** and is ground to $R_a 0.2 \mu\text{m}$ finish to ensure sealing.



NEW - Patented input sealing system design eliminates break away torque and decreases friction/heat. The hi-tech coating bushing (**3700 Hv, $R_a 0.2 \mu\text{m}$ finish**) interfaces with our proprietary seal which decreases wear and erosion of both sealing surfaces. This new patent prevents leakage and has a service life of over 20,000 hours.



Helical internal ring gear is machined directly into a single piece of steel. Maximized diameter and number of teeth to improve overall performance and torque capacity.



Specifications

Gearbox Performance

Model No.	Stages	Ratio	AB042	AB060	AB090	AB115	AB142	AB180	AB220	
Nominal Output Torque T_{2N}	1	3	20	55	130	208	342	588	1,140	
		4	19	50	140	290	542	1,050	1,700	
		5	22	60	160	330	650	1,200	2,000	
		6	20	55	150	310	600	1,100	1,900	
		7	19	50	140	300	550	1,100	1,800	
		8	17	45	120	260	500	1,000	1,600	
		9	14	40	100	230	450	900	1,500	
		10	14	40	100	230	450	900	1,500	
		2	15	20	55	130	208	342	588	1,140
			20	19	50	140	290	542	1,050	1,700
	25		22	60	160	330	650	1,200	2,000	
	30		20	55	150	310	600	1,100	1,900	
	35		19	50	140	300	550	1,100	1,800	
	40		17	45	120	260	500	1,000	1,600	
	45		14	40	100	230	450	900	1,500	
	50		22	60	160	330	650	1,200	2,000	
	60		20	55	150	310	600	1,100	1,900	
	70		19	50	140	300	550	1,100	1,800	
	80	17	45	120	260	500	1,000	1,600		
	90	14	40	100	230	450	900	1,500		
100	14	40	100	230	450	900	1,500			
Max. Output Torque T_{2B}	Nm	1,2	3 times of Nominal Output Torque							
Nominal Input Speed n_{1N}	rpm	1,2	3~100	5,000	5,000	4,000	4,000	3,000	3,000	2,000
Max. Input Speed n_{1B}	rpm	1,2	3~100	10,000	10,000	8,000	8,000	6,000	6,000	4,000
Micro Backlash P_0	arcmin	1	3~10	-	-	<1	<1	<1	<1	<1
		2	15~100	-	-	<3	<3	<3	<3	<3
Reduced Backlash P_1	arcmin	1	3~10	<3	<3	<3	<3	<3	<3	<3
		2	15~100	<5	<5	<5	<5	<5	<5	<5
Standard Backlash P_2	arcmin	1	3~10	<5	<5	<5	<5	<5	<5	<5
		2	15~100	<7	<7	<7	<7	<7	<7	<7
Torsional Rigidity	Nm/arcmin	1,2	3~100	3	7	14	25	50	145	225
Max. Radial Load F_{r2}^2	N	1,2	3~100	780	1,530	3,250	6,700	9,400	14,500	50,000
Max. Axial Load F_{a2}^2	N	1,2	3~100	390	765	1,625	3,350	4,700	7,250	25,000
Service Life	hr	1,2	3~100	20,000*						
Efficiency η	%	1	3~10	>97%						
		2	15~100	>94%						
Weight	kg	1	3~10	0.5	1.3	3.7	7.8	14.5	29	48
		2	15~100	0.8	1.5	4.1	9	17.5	33	60
Operating Temp	°C	1,2	3~100	-10°C~+90°C						
Lubrication		1,2	3~100	synthetic gear grease (NYOGEL 792D)						
Degree of Gearbox Protection		1,2	3~100	IP65						
Mounting Position		1,2	3~100	all directions						
Noise Level ($n_1=3000$ rpm)	dB	1,2	3~100	≤56	≤58	≤60	≤63	≤65	≤67	≤70

Gearbox Inertia

Model No.	Stages	Ratio	AB042	AB060	AB090	AB115	AB142	AB180	AB220	
Mass Moments of Inertia J_1	1	3	0.03	0.16	0.61	3.25	9.21	28.98	69.61	
		4	0.03	0.14	0.48	2.74	7.54	23.67	54.37	
		5	0.03	0.13	0.47	2.71	7.42	23.29	53.27	
		6	0.03	0.13	0.45	2.65	7.25	22.75	51.72	
		7	0.03	0.13	0.45	2.62	7.14	22.48	50.97	
		8	0.03	0.13	0.44	2.58	7.07	22.59	50.84	
		9	0.03	0.13	0.44	2.57	7.04	22.53	50.63	
		10	0.03	0.13	0.44	2.57	7.03	22.51	50.56	
		2	15	0.03	0.03	0.13	0.47	2.71	7.42	23.29
			20	0.03	0.03	0.13	0.47	2.71	7.42	23.29
	25		0.03	0.03	0.13	0.47	2.71	7.42	23.29	
	30		0.03	0.03	0.13	0.47	2.71	7.42	23.29	
	35		0.03	0.03	0.13	0.47	2.71	7.42	23.29	
	40		0.03	0.03	0.13	0.47	2.71	7.42	23.29	
	45		0.03	0.03	0.13	0.47	2.71	7.42	23.29	
	50		0.03	0.03	0.13	0.44	2.57	7.03	22.51	
	60		0.03	0.03	0.13	0.44	2.57	7.03	22.51	
	70		0.03	0.03	0.13	0.44	2.57	7.03	22.51	
	80	0.03	0.03	0.13	0.44	2.57	7.03	22.51		
	90	0.03	0.03	0.13	0.44	2.57	7.03	22.51		
100	0.03	0.03	0.13	0.44	2.57	7.03	22.51			

1. Ratio ($i=N_1/N_2$)
*S1 service life 10,000 hrs

2. F_{r2} , F_{a2} applied to the output shaft center @ 100 rpm

Dimensions (1-stage, Ratio i=3~10)

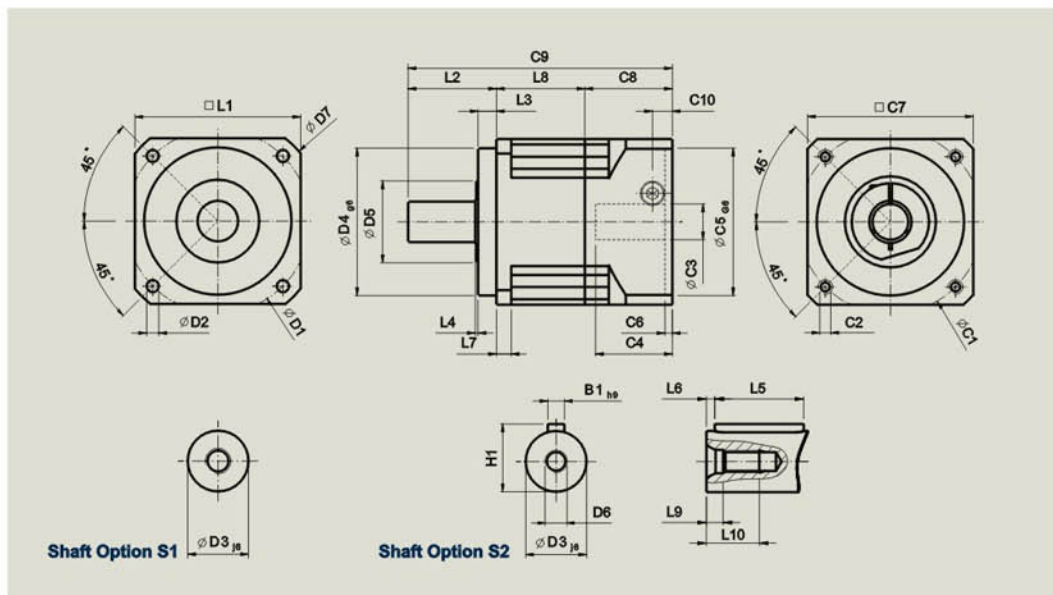

[unit: mm]

Dimension	AB042	AB060	AB090	AB115	AB142	AB180	AB220
D1	50	70	100	130	165	215	250
D2	3.4	5.5	6.6	9	11	13	17
D3 _{js}	13	16	22	32	40	55	75
D4 _{gs}	35	50	80	110	130	180	180
D5	22	45	60	80	75	95	115
D6	M4 x 0.7P	M5 x 0.8P	M8 x 1.25P	M12 x 1.75P	M16 x 2P	M20 x 2.5P	M20 x 2.5P
D7	56	80	116	152	185	240	292
L1	42	60	90	115	142	180	220
L2	26	37	48	65	97	105	138
L3	5.5	7	10	12	15	20	30
L4	1	1.5	1.5	2	3	3	3
L5	16	25	32	40	63	70	90
L6	2	2	3	5	5	6	7
L7	4	6	8	10	12	15	20
L8	31	35	48	61	71.5	84.5	93
L9	3.2	4	6	9.5	12	15	15
L10	10	12.5	19	28	36	42	42
C1 ³	46	70	100	130	165	215	235
C2 ³	M4 x 0.7P	M5 x 0.8P	M6 x 1P	M8 x 1.25P	M10 x 1.5P	M12 x 1.75P	M12 x 1.75P
C3 ³	≤11	*≤14 / ≤16	*≤19 / ≤24	≤32	≤38	≤48	≤55
C4 ³	25	30	40	50	60	82	82
C5 ³ _{gs}	30	50	80	110	130	180	200
C6 ³	3.5	4	4	5	6	6	6
C7 ³	42	60	90	115	142	190	220
C8 ³	29.5	41.5	48	61	71	96	100
C9 ³	86.5	113.5	144	187	239.5	285.5	331
C10 ³	8.75	10	11.25	13.5	16	18.25	20
B1 _{hb}	5	5	6	10	12	16	20
H1	15	18	24.5	35	43	59	79.5

3. C1-C10 are motor specific dimensions (metric std shown). Refer to Apexdyna.com and Design Tool to view your specific motor mounting system.
 *AB060 ratio 5,10 provides C3 ≤ 16 option. *AB090 ratio 3~10 provides C3 = 24 without ceramic bushing.

Dimensions (2-stage, Ratio $i=15\sim100$)

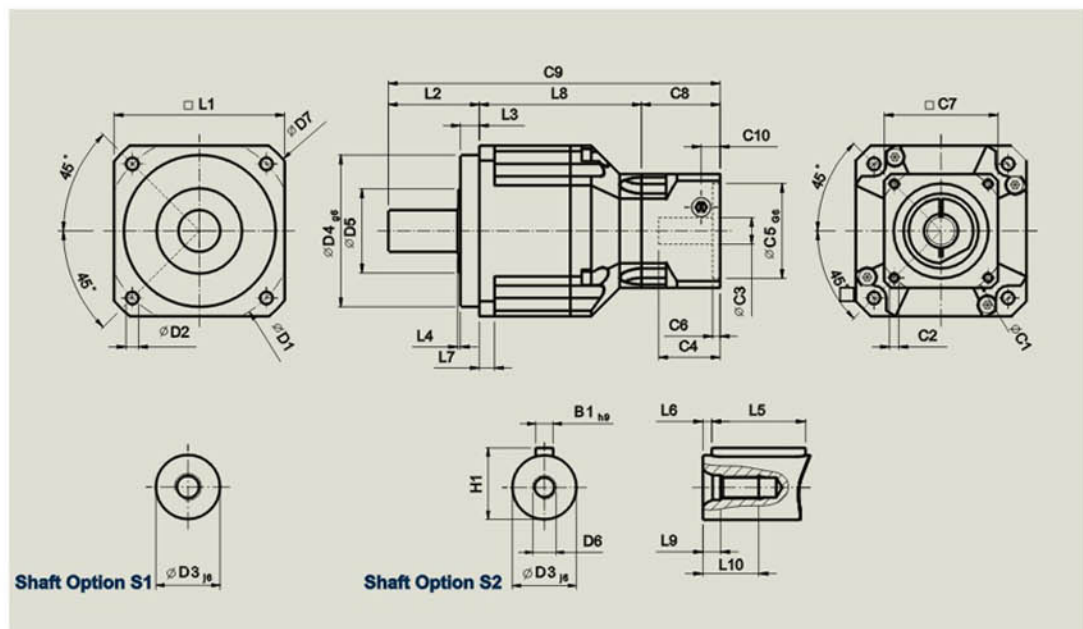

[unit: mm]

Dimension	AB042	AB060	AB090	AB115	AB142	AB180	AB220
D1	50	70	100	130	165	215	250
D2	3.4	5.5	6.6	9	11	13	17
D3 _{js}	13	16	22	32	40	55	75
D4 _{gs}	35	50	80	110	130	160	180
D5	22	45	60	80	75	95	115
D6	M4 x 0.7P	M5 x 0.8P	M8 x 1.25P	M12 x 1.75P	M16 x 2P	M20 x 2.5P	M20 x 2.5P
D7	56	80	116	152	185	240	292
L1	42	60	90	115	142	180	220
L2	26	37	48	65	97	105	138
L3	5.5	7	10	12	15	20	30
L4	1	1.5	1.5	2	3	3	3
L5	16	25	32	40	63	70	90
L6	2	2	3	5	5	6	7
L7	4	6	8	10	12	15	20
L8	58.5	72	85.5	113	135	161.5	178.5
L9	3.2	4	6	9.5	12	15	15
L10	10	12.5	19	28	36	42	42
C1 ⁴	46	46	70	100	130	165	215
C2 ⁴	M4 x 0.7P	M4 x 0.7P	M5 x 0.8P	M6 x 1P	M8 x 1.25P	M10 x 1.5P	M12 x 1.75P
C3 ⁴	≤11	*≤11 / ≤12	*≤14 / ≤15.875 / ≤16	*≤19 / ≤24	≤32	≤38	≤48
C4 ⁴	25	25	30	40	50	60	82
C5 _{gs} ⁴	30	30	50	80	110	130	180
C6 ⁴	3.5	3.5	4	4	5	6	6
C7 ⁴	42	42	60	90	115	142	190
C8 ⁴	29.5	29.5	41.5	48	61	71	96
C9 ⁴	114	138.5	175	226	293	337.5	412.5
C10 ⁴	8.75	8.75	10	11.25	13.5	16	18.25
B1 _{hp}	5	5	6	10	12	16	20
H1	15	18	24.5	35	43	59	79.5

4. C1-C10 are motor specific dimensions (metric std shown). Refer to Apexdyna.com and Design Tool to view your specific motor mounting system.

*AB060 ratio 15-50 provides C3 ≤ 12 option. *AB090 ratio 15-50 provides C3 ≤ 15.875 / ≤ 16 option. *AB115 ratio 15-100 provides C3 = 24 without ceramic bushing.



Selection of the Optimum Gearbox

Selection of the Optimum Gearbox

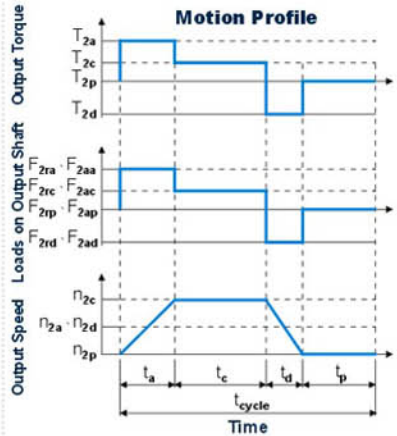
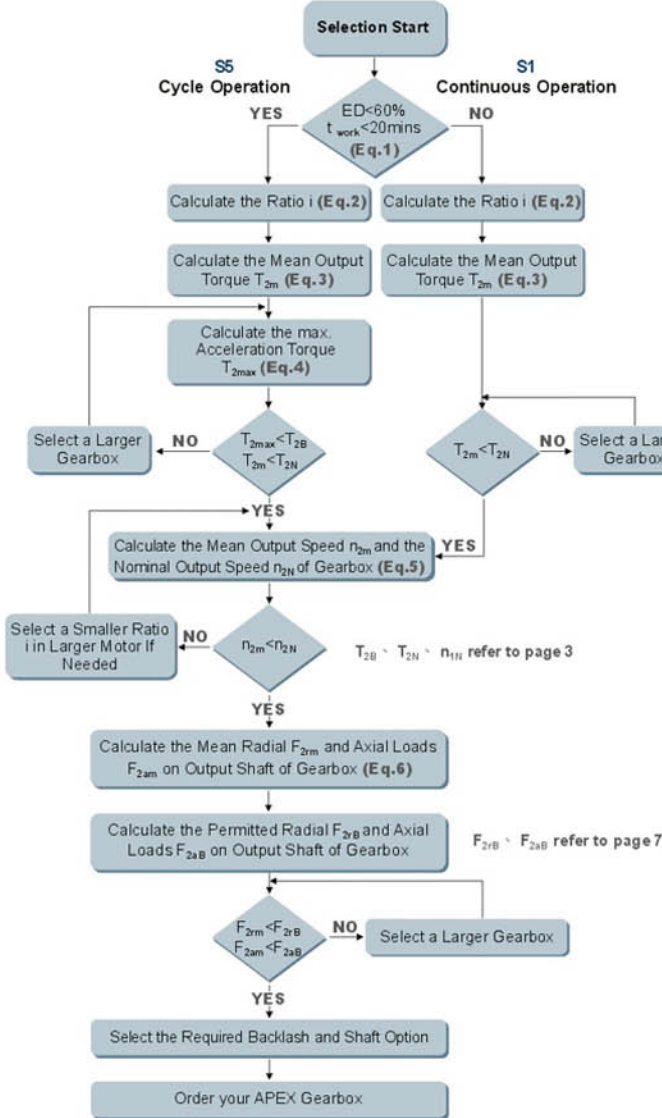

$$1. ED = \frac{t_a + t_c + t_d}{t_{cycle}} \times 100\%, t_{work} = t_a + t_c + t_d$$

Index : a. Acceleration, c. Constant, d. Deceleration, p. Pause (Eq. 1)

$$2. i \equiv \frac{n_m}{n_{work}}$$

n_m Output Speed of the Motor
 n_{work} Working Speed (Eq. 2)

$$3. T_{2m} = \sqrt[3]{\frac{n_{2a} \times t_a \times T_{2a}^3 + n_{2c} \times t_c \times T_{2c}^3 + n_{2d} \times t_d \times T_{2d}^3}{n_{2a} \times t_a + n_{2c} \times t_c + n_{2d} \times t_d}}$$

(Eq. 3)

$$4. T_{2max} = T_{mB} \times i \times K_s \times \eta$$

where K_s is

K_s	No. of Cycles / hr
1.0	0 ~ 1,000
1.1	1,000 ~ 1,500
1.3	1,500 ~ 2,000
1.6	2,000 ~ 3,000
1.8	3,000 ~ 5,000

T_{mB} Max. Output Torque of the Motor
 η Efficiency of the Gearbox (Eq. 4)

$$5. n_{2a} = n_{2d} = -\frac{1}{2} \times n_{2c}$$

$$n_{2m} = \frac{n_{2a} \times t_a + n_{2c} \times t_c + n_{2d} \times t_d}{t_a + t_c + t_d}$$

$$n_{2N} = \frac{n_m}{i}$$

(Eq. 5)

$$6. F_{2rm} = \sqrt[3]{\frac{n_{2a} \times t_a \times F_{2ra}^3 + n_{2c} \times t_c \times F_{2rc}^3 + n_{2d} \times t_d \times F_{2rd}^3}{n_{2a} \times t_a + n_{2c} \times t_c + n_{2d} \times t_d}}$$

$$F_{2am} = \sqrt[3]{\frac{n_{2a} \times t_a \times F_{2aa}^3 + n_{2c} \times t_c \times F_{2ac}^3 + n_{2d} \times t_d \times F_{2ad}^3}{n_{2a} \times t_a + n_{2c} \times t_c + n_{2d} \times t_d}}$$

(Eq. 6)

Recommended (for S5 Cycle Operation)
The general design is given for $\frac{J_k}{i^2} \leq 4 \times J_m$
The optimal design is given for $\frac{J_k}{i^2} \cong J_m$
 J_k Load Inertia
 J_m Motor Inertia



Permitted Radial and Axial Loads on Output Shaft of the Gearbox

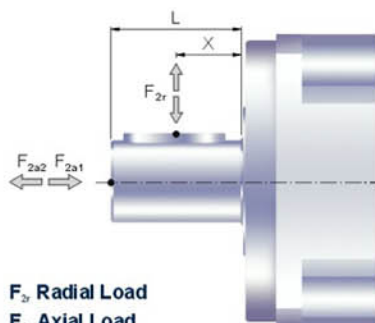

The permitted radial and axial loads on output shaft of the gearbox depend on the design of the gearbox supporting bearings. APEX use the extension straddle oversized ball bearing design. It can take heavy load from both axes.

F_{2r} Radial Load
 F_{2a} Axial Load

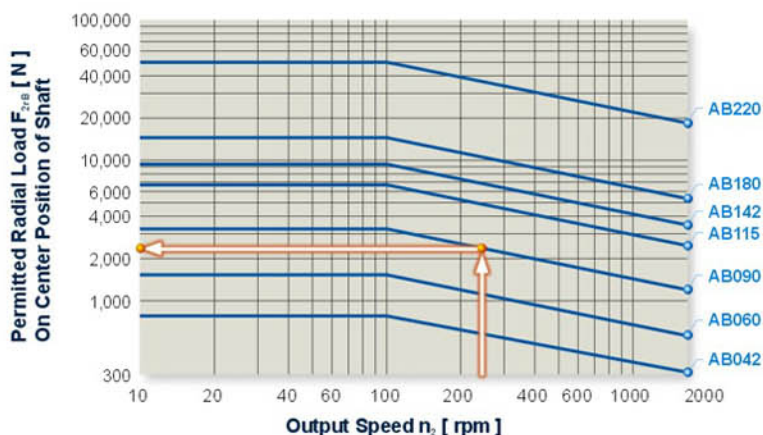

If radial force F_{2r} exert on the center of the output shaft $X=1/2 \times L$. Under various operating condition the lifetime is over 20,000 hours*. The permitted radial load is given on left diagram. The permitted axial load can be calculated by using the formula:

$$F_{2a1B} = 0.2 \times F_{2rB}$$

$$F_{2a2B} = 0.1 \times F_{2rB}$$

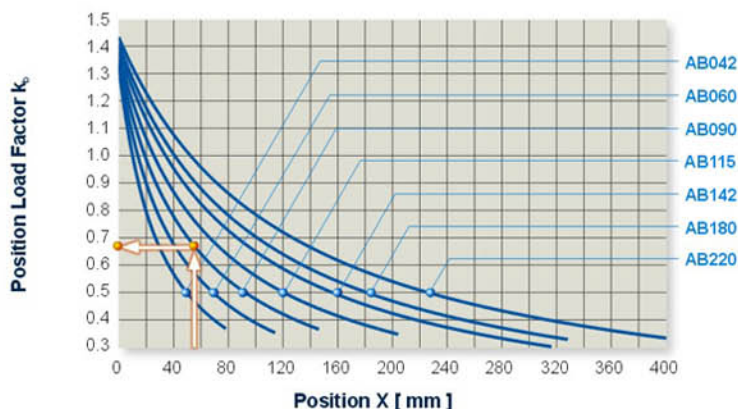

If radial force F_{2r} not exert on the center of the output shaft $X < 1/2 \times L$ or $X > 1/2 \times L$. The permitted radial and axial load can be calculated by the position load factor k_0 on the left diagram.

Radial load:

$$F'_{2rB} = k_0 \times F_{2rB}$$

Axial load:

$$F'_{2a1B} = 0.2 \times F'_{2rB}$$

$$F'_{2a2B} = 0.1 \times F'_{2rB}$$

* Continuous running reduces service life by 50%

Ordering Code



AB090

-

010

-

S1

-

P1

/

MOTOR

Gearbox Size:

AB042, AB060, AB090
AB115, AB142, AB180, AB220

Shaft Option:

S1: Smooth Output Shaft
S2: Output Shaft with Key

Motor Designation:

Manufacturer Type
And Model

Ratio:

1 Stage: 3, 4, 5, 6, 7, 8, 9, 10
2 Stages: 15, 20, 25, 30, 35, 40, 45, 50, 60, 70, 80, 90, 100

Backlash:

P0: Micro Backlash
P1: Reduced Backlash
P2: Standard Backlash

Ordering Example: AB090-010-S1-P1 / SIEMENS 1FT6 041-4AF71

S1 and S2 shaft options are shown below:

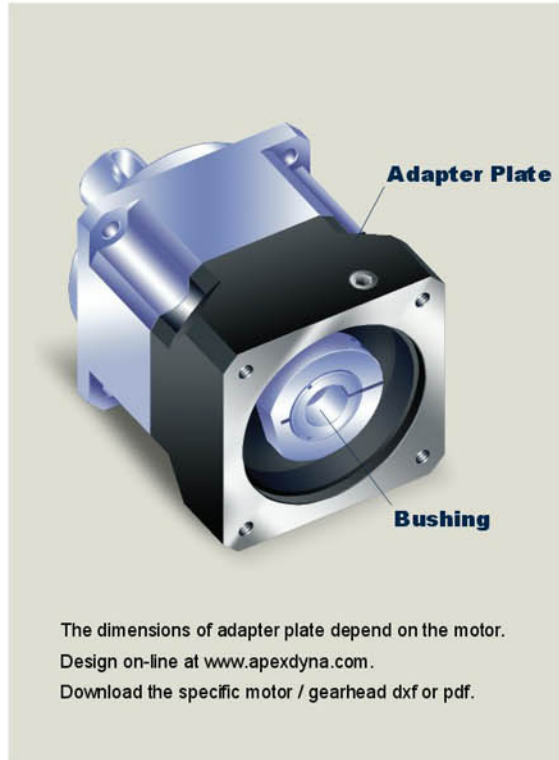
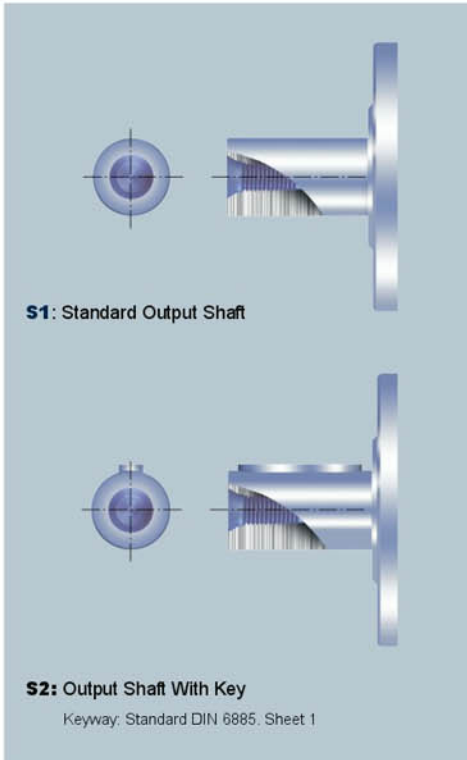

High Precision Planetary Gearboxes

www.apexdyna.com



APEX DYNAMICS, INC.

No. 6, 20th Rd., Taichung Industrial Park, Taichung, Taiwan, R.O.C.

Tel: 886 4 23550219 / Fax: 886 4 23550218

E-mail: sales@apexdyna.com

Website: www.apexdyna.com