



Ballscrews

An ideal drive mechanism where constant motion or high frequency cycling is required. Ballscrews provide highly efficient transmission with low starting torque, smooth running and quiet operation. Recirculating ball construction ensures low friction for smaller drive requirements along with high load capacity.

Ballscrews have many advantages over pneumatic or hydraulic drives including;

- No contamination from leaks
- High rigidity
- Positive direct drive
- High repeatability
- High accuracy
- Energy saving
- Low or even no backlash

Hiwin industrial grade ballscrews are available from stock in New Zealand. Stock leads range from 5 to 40mm to cover a wide range of feed rates. Hiwin are one of the leading linear component manufacturers in the world and can produce an enormous range of rolled or ground ballscrews from 8 to 100mm diameter and to ISO9000.



Ballscrew X-Y retrofits for mills



Rotating Nut ballscrews



High load drive 50 to 350T



Precision ground accuracy to 0.0035mm/300mm

Most types can be supplied as anti-backlash or preloaded version to increase system accuracy and eliminate lost motion. Different types such as cylindrical, double nut and block type are also available.

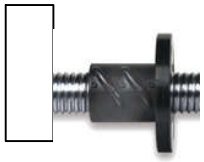

Hiwin FSI - Standard Lead

This is a standard lead, flanged form, single nut, industrial precision, rolled ballscrew, with internal return tubes. 5 or 10mm leads are suitable for the vast majority of applications.

- These are normally available ex stock
- Stock precision PR3 ($\pm 0.1\text{mm}/300\text{mm}$ travel)
- Din standard 69051 part 5 form B

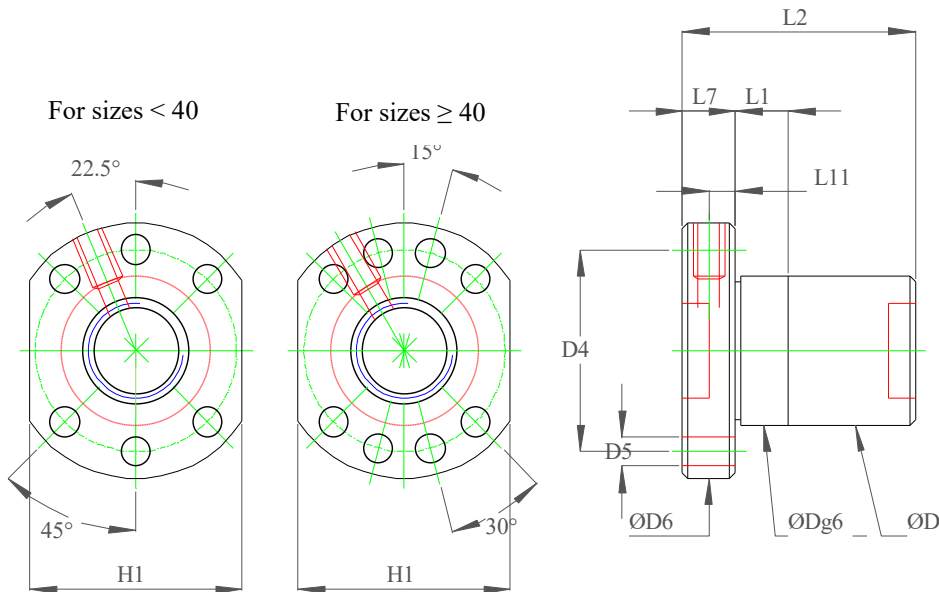

Model	Size		Dynamic Load 1×10^6 revs, C (kgf)	Static Load C_0 (kgf)	D	D4	# Flange holes	D5	D6	H1	L1	L2	L7	L11	M-oil hole	Axial Play
	Nominal Dia	Lead			Boss dia	PCD		fastener dia	OD	Across faces	shoulder width	Length	Flange thickness	nipple position		
16-5T3	16	5	664	1196	28	38	6	5.5	48	40	10	44	10	5	M6x1P	0.07
20-5T4	20	5	939	1993	36	47	6	6.6	58	44	10	52	10	5	M6x1P	0.07
25-5T4	25	5	1127	2776	40	51	6	6.6	62	48	12	52	10	5	M6x1P	0.07
25-10T3	25	10	1430	2914	40	51	6	6.6	62	48	16	74	10	5	M6x1P	0.12
32-5T4	32	5	1291	3697	50	65	6	9	80	62	10	53	12	6	M6x1P	0.07
32-10T4	32	10	2900	6404	50	65	6	9	80	62	16	85	12	6	M6x1P	0.15
40-10T4	40	10	3396	8489	63	78	8	9	93	70	16	87	14	7	M8x1P	0.15
50-10K6	50	10	7450	25350	75	93	8	11	110	85	16	90	16	8	M8x1P	0.15

1kgf = 9.81N Items in bold type are normal stock lines.

Material specification for FSI and FSH shafts is to cf53 DIN standard;

- Yield strength: 680N/mm²
- Tensile strength: 840N/mm²



Hiwin FSH – High Lead

This is a high lead, flanged form factor, single nut, industrial precision, rolled ballscrew, with internal return tubes. The higher lead of this type gives more travel per revolution of the shaft to reduce shaft speeds and reduce whipping of the shaft. These are ideal for faster travel speeds and high cycling mechanisms.

- These are normally available ex stock
- Stock precision PR3 ($\pm 0.1\text{mm}/300\text{mm}$ travel)

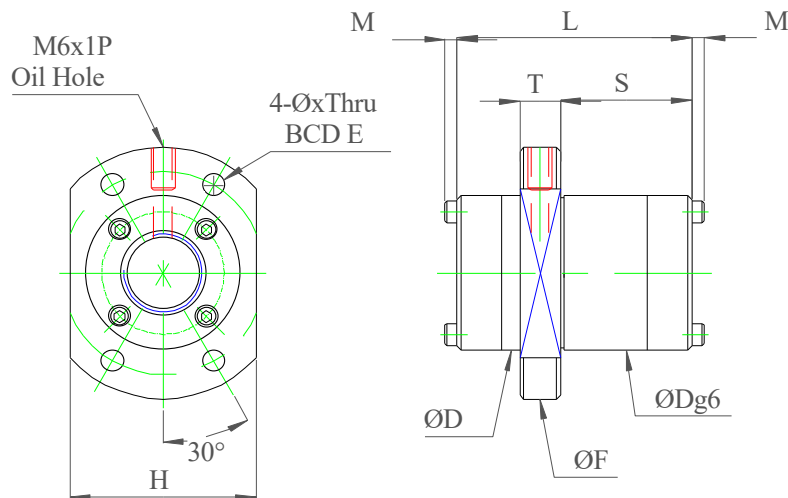

Model	Size		Ball dia	Dynamic Load 1x 10 ⁶ revs C (kgf)	Static Load C ₀ (kgf)	D Boss dia	BCD-E PCD	X Fastner	F OD	H Across faces	L Length	T Flange thickness	S Boss length	M cap screw length	M-oil hole	Axial Play
	Nominal Dia	Lead														
16-16S4	16	16	3.18	1290	2760	33	45	6.6	58	38	48	10	26	0	M6x1P	0.07
20-20S4	20	20	3.18	1450	3480	38	50	5.5	62	46	58	10	32.5	3	M6x1P	0.07
25-25S4	25	25	3.97	2190	5600	47	60	6.6	74	56	67	12	39.5	3	M6x1P	0.1
32-32S4	32	32	4.76	3110	8530	58	74	9	92	68	85	15	48	0	M6x1P	0.12
40-40S4	40	40	6.35	5100	14330	72	93	11	114	84	102	17	60	0	M6x1P	0.15
50-50S4	50	50	7.94	7470	21780	90	112	14	135	104	125	20	83.5	0	M6x1P	0.17

1kgf = 9.81N Items in bold type are normal stock lines.



SBC DIN Standard

SBC use rolled shaft which is one of the highest accuracy rolled ball screw in the world. This is a great way of getting a higher precision at a more attractive price and much shorter lead time than a precision ground screw.

The SDK and SDH type nuts conform to the European DIN standard sizes. Some types are available from stock in NZ in C5 ($\pm 0.023\text{mm}/300\text{mm}$). Others types can be supplied on short lead times.

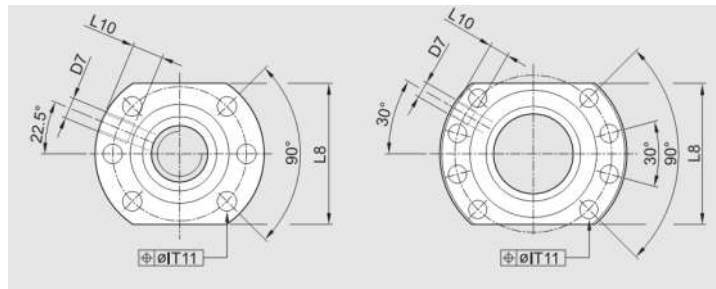
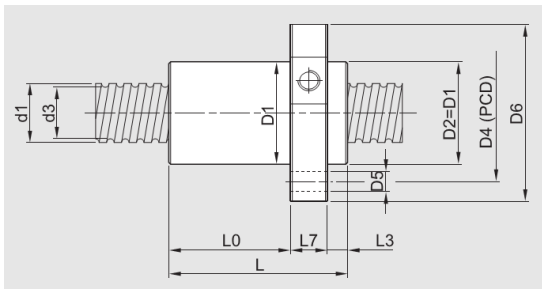

For sizes < 40

For sizes ≥ 40

Model	Ph	d2	Sa	D1 (g6)	D4	D5	D6	L (± 1)	L0 (± 1)	L3 (-0.5)	L7	L8	D7	Ca	Coa
	Lead	Root Dia	Backlash	Boss	PCD	Fastener	Flange OD	Overall Length	Boss Length			Across faces	Grease Nipple	1×10^6 revs (kN)	(kN)
SDK 1605	5	12.7	0.05	28	38	5.5	48	48.5	33	5.5	10	40	M6x1	9.5	10.9
SDH 1610	10	13.4	0.05	28	38	5.5	48	45	26	9	10	40	M6x1	7	12
SDH 1616	16	13.4	0.05	28	38	5.5	48	48	28	10	10	40	M6x1	7.1	14
SDK 2005	5	16.7	0.05	36	47	6.6	58	48.5	33	5.5	10	44	M6x1	11.5	15.5
SDK 2010	10	16.9	0.05	36	47	6.6	58	69	53	6	10	44	M6x1	13.6	19
SDH 2020	20	16.7	0.05	36	47	6.6	58	54	33	11	10	44	M6x1	10.8	18.6
SDK 2505	5	21.7	0.05	40	51	6.6	62	49	33	6	10	48	M6x1	13.1	20.2
SDK 2510	10	21.7	0.05	40	51	6.6	62	80	64	6	10	48	M6x1	19	38
SDH 2525	25	21.7	0.05	40	51	6.6	62	64	41	11	12	48	M6x1	13.1	26
SDK 3205	5	28.7	0.05	50	65	9	80	57	39	6	12	62	M6x1	19.3	36.3
SDK 3210	10	27.1	0.06	50	65	9	80	73	55	6	12	62	M6x1	26.4	39
SDH 3220	20	27.1	0.06	56	71	9	86	83	57	14	12	68	M6x1	47.2	83.2
SDH 3232	32	28.2	0.06	56	71	9	86	83	54	17	12	68	M6x1	17.2	53.9
SDK 4005	5	36.7	0.06	63	78	9	93	66	45	7	14	70	M8x1	26.3	59.2
SDK 4010	10	34	0.06	63	78	9	93	88.5	67.5	7	14	70	M8x1	64.9	109
SDH 4020	20	35.2	0.06	63	78	9	93	83	56	13	14	70	M8x1	52.2	103.6
SDH 4040	40	34	0.06	70	85	9	100	102	67	21	14	77	M8x1	59.7	108.9
SDK 5010	10	43	0.06	75	93	11	110	92	69	7	16	85	M8x1	66.4	134.3
SDH 5020	20	44.6	0.06	75	93	11	110	85	56	13	16	85	M8x1	78.8	188.7
SDK 6310	10	56.9	0.06	90	108	11	125	103.5	78.5	7	18	95	M8x1	93.8	229.7
SDH 6320	20	56.9	0.06	95	115	13.5	135	92	48	24	20	100	M8x1	103.1	270.8
SDK 8010	10	73.9	0.06	105	125	13.5	145	121	92	9	20	110	M8x1	121.9	374.9
SDH 8020	20	73.7	0.06	125	145	13.5	165	154	129	-	25	130	M8x1	83.2	302.9

1kgf = 9.81N Ca = dynamic load capacities, Coa = static load capacities



SBC MBS – Miniature

SBC also offer a range of miniature ball screws for case where space and/or ultra-fine leads are required. These are available from the factory on short lead times.

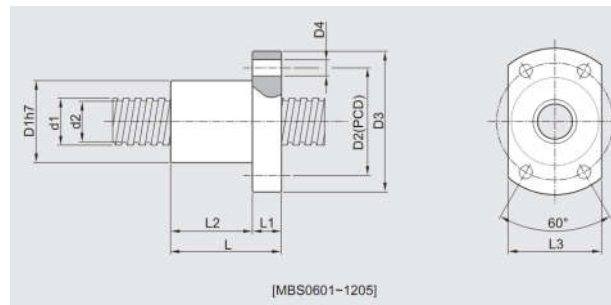

Model	Circuits	Root dia	Lead	Ball size	C_a	C_{ao}	D1	D3	L	L1	L2	D2	L3	D4
					1×10^6 revs (kN)	(kN)								
MBS0601	3x1	5.5	1	0.8	73	121	13	27	15	3.5	11.5	21.5	17	3.4
MBS0801	4x1	7.4	1	0.8	93	173	16	30	16	4	12	24	18	3.4
MBS0802	3x1	7.2	2	1.2	135	225	16	30	16	4	12	24	18	3.4
MBS0802.5	2.5x1	7.2	2.5	1.2	151	232	20	38	21	5	16	30	23	4.5
MBS1002	3x1	8.4	2	2	183	305	18	35	28	5	23	27	22	4.5
MBS1004	3x1	8.6	4	2	394	589	26	46	34	10	24	36	28	4.5
MBS1204	3.5x1	10	4	2.381	425	738	28	48	30	6	24	39	30	5.5
MBS1205	3.5x1	10.4	5	2	662	1036	28	48	35	6	29	39	30	5.5
MBS1210	2x1	10	10	2	255	366	30	45	40	10	30	40	32	4.5

1kgf = 9.81N C_a = dynamic load capacities, C_{ao} = static load capacities

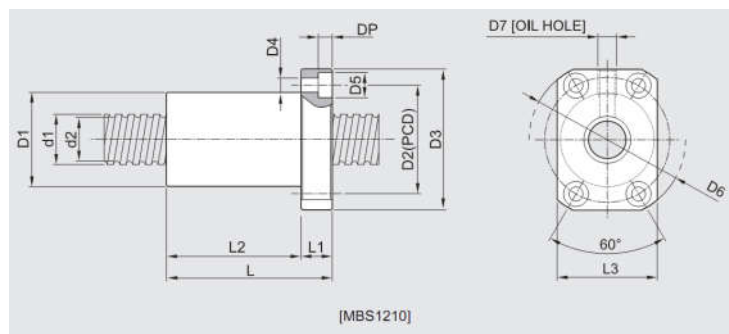

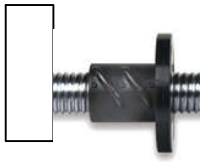

Ballscrew actuators and stages

SBC and Hiwin manufacture ballscrew actuators and stages ready to bolt in to a wide range of applications. Open frame, bellows and fully sealed clean room types can be supplied on short lead times.

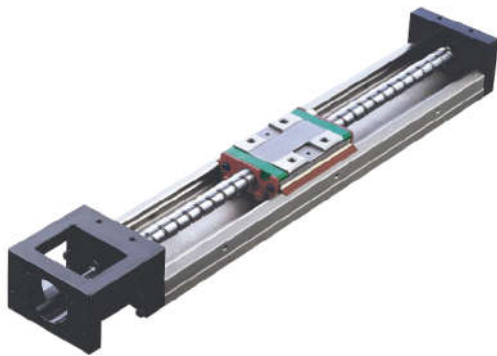

Hiwin KK type integrated guide– optional bellows

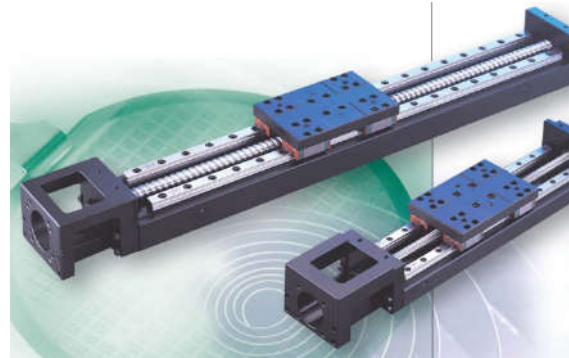

Hiwin KA type profile guide type



Hiwin KS type – clean room class



Hiwin integrated linear motor stages. Also available in XY and gantry configurations.



SBC Ballscrew clean room class actuator



SBC also manufacture high load precision cross roller guides and tables. Ideal for miniature precision applications, robot grippers, and semiconductor handling.