

TOSHIBA

Leading Innovation >>>



32AV83*B
32/40LV83*B
26/32EL83*B
32/42HL83*B
DIGITAL
Series

> IN NEED OF HELP



IF YOU ARE EXPERIENCING
ANY DIFFICULTIES PLEASE VISIT
WWW.TOSHIBA.CO.UK/TV-DVD-SUPPORT



OR CONTACT THE TOSHIBA
CUSTOMER HELPLINE ON
0844 856 0730

Register your TV online at:
www.toshiba.co.uk/registration



Contents

Safety Precautions	5	Frequently Asked Questions	24
Air Circulation	5	Using the Controls	26
Heat Damage	5	Switching On	27
Mains Supply	5	Using the Remote Control	27
Do	5	Using the Side-Key Controls	27
Do not	5	Tuning the Television	28
Installation and important information.....	6	Quick Setup	28
Where to install.....	6	Setting the Channels.....	30
When using a Wall Bracket	6	Auto Tuning	30
The Remote Control	12	Manual Tuning.....	31
Inserting batteries and effective range of the remote.....	12	Automatic Power Down	33
Connecting External Equipment.....	13	Reset TV	33
HDMI-LINK Connections	15	DTV Settings	34
Connecting an HDMI or DVI device to the HDMI input.....	16	Channels	34
To connect an HDMI device	16	Channel Options.....	35
To connect a DVI device.....	18	Subtitle and Audio	36
Connecting a Computer.....	20	Password.....	36
To connect a PC to the HDMI terminal.....	20	Parental.....	36
Acceptable Video signals through HDMI terminals.....	22	Common Interface.....	36
Acceptable PC signals through HDMI terminals.....	22	General Controls	37
Digital On-Screen Information and Programme Guide	23	Selecting Channels	37
Information	23	Stereo and Bilingual Transmissions	37
On-Screen Information Icons	23	Quick Access Menu.....	37
Guide.....	23	Subtitles.....	37
		Picture Still	37
		Input Selection.....	37
		Sound Controls.....	38
		Volume Controls and Mute Sound.....	38
		Dual.....	38
		Bass, Treble and Balance	38
		Stable Sound.....	38

Surround Sound	38	Enjoy Videos through USB	
Bass Boost	38	Port	49
SPDIF Type	38	Play Video Files.....	50
Audio Description	39	Repeat Settings.....	51
Widescreen viewing	40	Set	51
Available Picture Size and Position		Slow Forward	51
Control.....	41	Step Forward.....	51
Picture Controls.....	42	Using the Play List.....	51
Picture Position	42	Video Info	51
Picture Mode	42	Goto Time.....	51
Picture Preferences.....	42	HDMI-LINK Controls	52
Black/White Level.....	43	Equipment Control.....	52
Cinema Mode.....	43	Input Source Selection	52
Colour Temperature.....	43	HDMI-LINK Menus	53
Static Gamma.....	43	One Touch Play	53
Reset.....	43	System Standby	53
Active Backlight.....	43	System Audio Control.....	53
3D Colour Management	43	Enable HDMI-LINK.....	53
Base Colour Adjustment.....	44	Auto Power On.....	53
Digital Noise Reduction	44	Auto Standby.....	54
MPEG NR – Noise Reduction	44	Amplifier Control.....	54
Enjoy Photos through USB		Speaker Preference	54
Port	45	Preference Controls	55
View Photo Files.....	45	On Timer.....	55
Using Slide Show	46	Sleep Timer	55
Repeat Settings for Slideshow	46	EPG.....	56
Set Interval Time	46	Panel Lock.....	57
Using the Play List.....	46	Auto Format (Widescreen)	57
Photo Info.....	46	4:3 Stretch.....	57
Enjoy Music through USB		Blue Screen.....	57
Port	47	Side Panel.....	57
Play Music Files	47	System Information	57
Repeat Settings.....	48	System Upgrade.....	58
Using the Play List.....	48	Text Services and Text	
Music Info.....	48	Information.....	59

Setting the Modes	59
Navigating Pages using Auto	59
Navigating Pages using LIST	59
Control Buttons.....	59
PC Settings	60
Horizontal and Vertical Position.....	60
Horizontal Width	60
Clock Phase	60
Reset.....	60
Input Selection and AV Connections.....	61
HDMI1 Audio	61
Lip Sync Mode	61
Input Signal Selection.....	61
Specifications and Accessories	62

Safety Precautions

This equipment has been designed and manufactured to meet international safety standards but, like any electrical equipment, care must be taken to obtain the best results and for safety to be assured. Please read the points below for your own safety. They are of a general nature, intended to help with all electronic consumer products and some points may not apply to the goods you have just purchased.

The Class I apparatus shall be connected to a mains socket outlet with a protective earthing connection.

Air Circulation

Leave more than 10cm clearance around the television to allow adequate ventilation. This will prevent overheating and possible damage to the television. Dusty places should also be avoided.

Heat Damage

Damage may occur if the television is left in direct sunlight or near a heater. Avoid places subject to extremely high temperatures or humidity. Place in a location where the temperature remains between 5°C (41°F) min. and 35°C (94°F) max.

Mains Supply

The mains supply required for this equipment is 220-240v AC 50/60Hz. Never connect to a DC supply or any other power source. DO ensure that the television is not standing on the mains lead. Use only the supplied lead.

DO NOT cut off the mains plug from this equipment, this incorporates a special Radio Interference Filter, the removal of which will impair its performance. In the UK, the fuse fitted in this plug is approved by ASTA or BSI to BS1362.

It should only be replaced by a correctly rated and approved type and the fuse cover must be refitted.

IF IN DOUBT PLEASE CONSULT A COMPETENT ELECTRICIAN.

Do

DO read the operating instructions before you attempt to use the equipment.

DO ensure that all electrical connections (including the mains plug, extension leads and inter-connections between pieces of equipment) are properly made and in accordance with the manufacturers' instructions. Switch off and withdraw the mains plug before making or changing connections.

DO consult your dealer if you are ever in doubt about the installation, operation or safety of your equipment.

DO be careful with glass panels on equipment.

DO NOT REMOVE ANY FIXED COVERS AS THIS WILL EXPOSE DANGEROUS AND 'LIVE' PARTS.

THE MAINS PLUG IS USED AS A DISCONNECTING DEVICE AND THEREFORE SHOULD BE READILY OPERABLE.

Do not

DO NOT obstruct the ventilation openings of the equipment with items such as newspapers, tablecloths, curtains, etc. Overheating will cause damage and shorten the life of the equipment.

DO NOT allow electrical equipment to be exposed to dripping or splashing or objects filled with liquids, such as vases, to be placed on the equipment.

DO NOT place hot objects or naked flame sources, such as lighted candles or nightlights on, or close to equipment. High temperatures can melt plastic and lead to fires.

DO NOT use makeshift stands and NEVER fix legs with wood screws. To ensure complete safety, always fit the manufacturers' approved stand, bracket or legs with the fixings provided according to the instructions.

DO NOT leave equipment switched on when it is unattended, unless it is specifically stated that it is designed for unattended operation or has a standby mode. Switch off by withdrawing the plug, make sure your family know how to do this. Special arrangements may need to be made for people with disabilities.

DO NOT continue to operate the equipment if you are in any doubt about it working normally, or it is damaged in any way – switch off, withdraw the mains plug and consult your dealer.

WARNING – excessive sound pressure from ear-phones or headphones can cause hearing loss.

ABOVE ALL – NEVER let anyone, especially children, push or hit the screen, push anything into holes, slots or any other openings in the case.

NEVER guess or take chances with electrical equipment of any kind – it is better to be safe than sorry.

Installation and important information

Where to install

Locate the television away from direct sunlight and strong lights, soft, indirect lighting is recommended for comfortable viewing. Use curtains or blinds to prevent direct sunlight falling on the screen.

Place the TV set on a stable, level surface that can support the weight of the TV. As an additional safety measure you secure the TV to the level surface or a wall, as shown in the illustration, using sturdy strap.

The LCD display panels are manufactured using an extremely high level of precision technology, however sometimes some parts of the screen may be missing picture elements or have luminous spots. This is not a sign of a malfunction.

Make sure the television is located in a position where it cannot be pushed or hit by objects, as pressure will break or damage the screen. Also, please be certain that small items cannot be inserted into slots or openings in the case.

Cleaning the screen and cabinet...

Turn off the power, and clean the screen and cabinet with a soft, dry cloth. We recommend that you **do not** use any proprietary polishes or solvents on the screen or cabinet as this may cause damage.

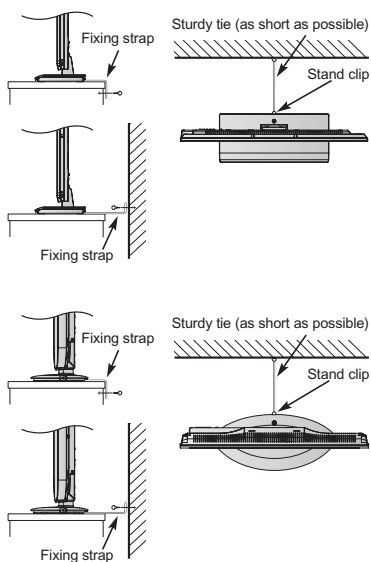

Stand style is dependent on model

When using a Wall Bracket

Please use a wall bracket appropriate for the size and weight of the LCD TV.

- Two people are required for installation.
- **Never use the four screws attached to the TV.**
- To install a wall-mount from another manufacturer, use the **SPACERS** (supplied).

1. Unplug and remove any cables and/or other component connectors from the rear of the TV.
2. Carefully lay the front of the unit face down on a flat, cushioned surface such as a quilt or blanket.
3. Follow the instructions provided with your wall bracket. Before proceeding, make sure the appropriate bracket(s) are attached to the wall and the back of the TV as described in the instructions provided with the wall bracket.
4. Make sure to place the spacers supplied between the bracket and the back of the TV.
5. Always use the screws supplied or recommended by the wall mount manufacturer.

*Screw Type for Wall Bracket:

- 26LED, 32CCFL, 32LED, 40CCFL: M6/10mm/20KG
- 42LED: M8/12mm/20KG

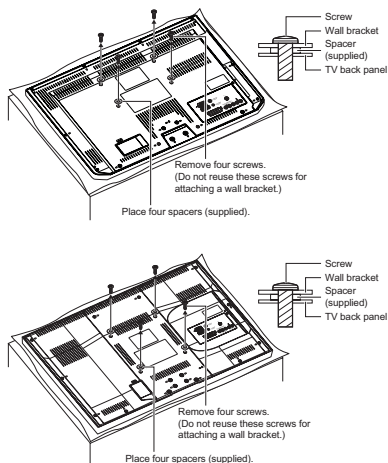

Removing the Pedestal Stand:

1. Carefully lay the front of the unit face down on a flat, cushioned surface such as a quilt or a blanket. Leave the stand protruding over the edge of the surface.

NOTE: Extreme care should always be used when removing the pedestal stand to avoid damage to the LCD panel.

2. Remove the screws.



3. Once you have removed all five screws holding the pedestal stand in place, remove the pedestal stand from the TV by sliding the pedestal stand away from the TV.

Please take note**EXCLUSION CLAUSE**



Toshiba shall under no circumstances be liable for loss and/or damage to the product caused by:

- i) fire;
- ii) earthquake;
- iii) accidental damage;
- iv) intentional misuse of the product;
- v) use of the product in improper conditions;
- vi) loss and/or damage caused to the product while in the possession of a third party;
- vii) any damage or loss caused as a result of the owner's failure and/or neglect to follow the instructions set out in the owner's manual;
- viii) any loss or damage caused directly as a result of misuse or malfunction of the product when used simultaneously with associated equipment;

Furthermore, under no circumstances shall Toshiba be liable for any consequential loss and/or damage including but not limited to the following, loss of profit, interruption of business, the loss of recorded data whether caused during normal operation or misuse of the product.

- If stationary images generated by 4:3 broadcasts, text services, channel identification logos, computer displays, video games, on-screen menus, etc. are left on the television-screen for any length of time they could become conspicuous, it is always advisable to reduce both the brightness and contrast settings.
- Very long, continuous use of the 4:3 picture on a 16:9 screen may result in some retention of the image at the 4:3 outlines, this is not a defect of the LCD TV and is not covered under the manufacturer's warranty. Regular use of other size modes (e.g.: Superlive) will prevent permanent retention.

NOTE: Interactive video games that involve shooting a "gun" type of joystick at an on-screen target may not work with this TV.

SYMBOL	SYMBOL DEFINITION
	<p>DANGEROUS VOLTAGE: The lightning flash with arrowhead symbol within an equilateral triangle is intended to alert the user to the presence of un-insulated "DANGEROUS VOLTAGE" within the product's enclosure that may be of sufficient magnitude to constitute a risk of electric shock to persons.</p>
	<p>INSTRUCTIONS: The exclamation point within an equilateral triangle to alert the user to the presence of important operating and maintenance (servicing) instruction in the literature accompanying the appliance.</p>
	<p>WARNING: To prevent the spread of fire, keep candles or other open flames away from this product at all times.</p>

Re-tuning: TOSHIBA Freeview products

4 Steps
(Steps 1-4)

This guide can be used to help you re-tune the following product with the remote control below:

TOSHIBA Digital TV

Make sure your TV is on and press 80 for the BBC News channel

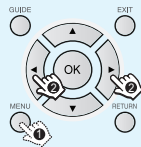

- 1) Press **MENU** and press
◀ or ▶ to select **SETUP**.

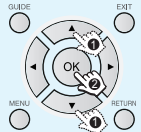

- 2) Press **▲** or **▼** to select
Auto tuning, and press
Ⓚ to enter the sub-menu.

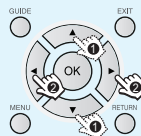
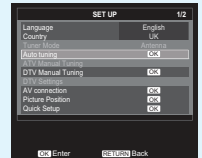

- 3) Press **▲** or **▼** to select
Tuning Mode and press
◀ or ▶ to select **ATV**,
DTV or **ATV and DTV**.

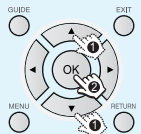
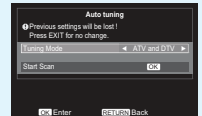

- 4) Press **▲** or **▼** to select
Start Scan and press **Ⓚ**
to start **Auto tuning**.

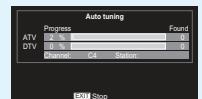

TOSHIBA Customer Helpline: 0844 856 0730

TOSHIBA Online Support:
www.toshiba.co.uk/tv-dvd-support

*This process may affect any saved information stored on your product, including your favourites list.
Please consult your instruction manual or contact the manufacturer using the details above.

Your guide to

Manual re-tuning

If you are comfortable with technical information and your basic re-tune hasn't worked, you can use this manual re-tune guide.

If your Freeview TV or box picks up a different regional service to your preferred service (e.g. BBC England instead of BBC Scotland, or ITV Central instead of ITV Anglia), you can use this manual re-tune guide.

If you are missing some services you may find they have moved to channel 800 or above, this guide will help you put them in your preferred position.

If you find manual re-tuning too difficult, contact your local electrical retailer or installer. This is a guide only, Freeview models operate slightly differently. Some early models do not offer a manual re-tune facility – check your instruction book.

Please note:

Every time you re-tune, you will need to go through this process.

1

Go to the Postcode Checker at digitaluk.co.uk

Enter your postcode on the right hand side of the web page. Remember to include your house number or name. If you do not have internet access, contact the Digital UK helpline on 08456 50 50 50 * and ask for manual re-tune guide support.



2

Once you have entered your address details, the next page gives you an indication of which TV services you should receive, based on your most likely transmitter. You may be able to receive television services from more than one transmitter and you can check alternatives, where available.

On the results page click on the pink button to see your full reception forecast and channel information for switchover.

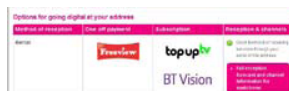

3

Click on the How do I re-tune? pink banner.

Scroll down to the manual re-tune table where you will see the relevant "RF Channel" numbers for the digital services that can be received at your home.**

TVset	During	Final swop
1st Day 2008	1st Day 2008	2 Day 2008
2 Day 2008	2 Day 2008	3 Day 2008
3 Day 2008	3 Day 2008	4 Day 2008
4 Day 2008	4 Day 2008	5 Day 2008
5 Day 2008	5 Day 2008	6 Day 2008
6 Day 2008	6 Day 2008	7 Day 2008
7 Day 2008	7 Day 2008	8 Day 2008
8 Day 2008	8 Day 2008	9 Day 2008
9 Day 2008	9 Day 2008	10 Day 2008
10 Day 2008	10 Day 2008	11 Day 2008
11 Day 2008	11 Day 2008	12 Day 2008
12 Day 2008	12 Day 2008	13 Day 2008
13 Day 2008	13 Day 2008	14 Day 2008
14 Day 2008	14 Day 2008	15 Day 2008
15 Day 2008	15 Day 2008	16 Day 2008
16 Day 2008	16 Day 2008	17 Day 2008
17 Day 2008	17 Day 2008	18 Day 2008
18 Day 2008	18 Day 2008	19 Day 2008
19 Day 2008	19 Day 2008	20 Day 2008
20 Day 2008	20 Day 2008	21 Day 2008
21 Day 2008	21 Day 2008	22 Day 2008
22 Day 2008	22 Day 2008	23 Day 2008
23 Day 2008	23 Day 2008	24 Day 2008
24 Day 2008	24 Day 2008	25 Day 2008
25 Day 2008	25 Day 2008	26 Day 2008
26 Day 2008	26 Day 2008	27 Day 2008
27 Day 2008	27 Day 2008	28 Day 2008
28 Day 2008	28 Day 2008	29 Day 2008
29 Day 2008	29 Day 2008	30 Day 2008
30 Day 2008	30 Day 2008	31 Day 2008
31 Day 2008	31 Day 2008	1st Day 2009
1st Day 2009	1st Day 2009	2nd Day 2009
2nd Day 2009	2nd Day 2009	3rd Day 2009
3rd Day 2009	3rd Day 2009	4th Day 2009
4th Day 2009	4th Day 2009	5th Day 2009
5th Day 2009	5th Day 2009	6th Day 2009
6th Day 2009	6th Day 2009	7th Day 2009
7th Day 2009	7th Day 2009	8th Day 2009
8th Day 2009	8th Day 2009	9th Day 2009
9th Day 2009	9th Day 2009	10th Day 2009
10th Day 2009	10th Day 2009	11th Day 2009
11th Day 2009	11th Day 2009	12th Day 2009
12th Day 2009	12th Day 2009	13th Day 2009
13th Day 2009	13th Day 2009	14th Day 2009
14th Day 2009	14th Day 2009	15th Day 2009
15th Day 2009	15th Day 2009	16th Day 2009
16th Day 2009	16th Day 2009	17th Day 2009
17th Day 2009	17th Day 2009	18th Day 2009
18th Day 2009	18th Day 2009	19th Day 2009
19th Day 2009	19th Day 2009	20th Day 2009
20th Day 2009	20th Day 2009	21st Day 2009
21st Day 2009	21st Day 2009	22nd Day 2009
22nd Day 2009	22nd Day 2009	23rd Day 2009
23rd Day 2009	23rd Day 2009	24th Day 2009
24th Day 2009	24th Day 2009	25th Day 2009
25th Day 2009	25th Day 2009	26th Day 2009
26th Day 2009	26th Day 2009	27th Day 2009
27th Day 2009	27th Day 2009	28th Day 2009
28th Day 2009	28th Day 2009	29th Day 2009
29th Day 2009	29th Day 2009	30th Day 2009
30th Day 2009	30th Day 2009	31st Day 2009
31st Day 2009	31st Day 2009	1st Day 2010
1st Day 2010	1st Day 2010	2nd Day 2010
2nd Day 2010	2nd Day 2010	3rd Day 2010
3rd Day 2010	3rd Day 2010	4th Day 2010
4th Day 2010	4th Day 2010	5th Day 2010
5th Day 2010	5th Day 2010	6th Day 2010
6th Day 2010	6th Day 2010	7th Day 2010
7th Day 2010	7th Day 2010	8th Day 2010
8th Day 2010	8th Day 2010	9th Day 2010
9th Day 2010	9th Day 2010	10th Day 2010
10th Day 2010	10th Day 2010	11th Day 2010
11th Day 2010	11th Day 2010	12th Day 2010
12th Day 2010	12th Day 2010	13th Day 2010
13th Day 2010	13th Day 2010	14th Day 2010
14th Day 2010	14th Day 2010	15th Day 2010
15th Day 2010	15th Day 2010	16th Day 2010
16th Day 2010	16th Day 2010	17th Day 2010
17th Day 2010	17th Day 2010	18th Day 2010
18th Day 2010	18th Day 2010	19th Day 2010
19th Day 2010	19th Day 2010	20th Day 2010
20th Day 2010	20th Day 2010	21st Day 2010
21st Day 2010	21st Day 2010	22nd Day 2010
22nd Day 2010	22nd Day 2010	23rd Day 2010
23rd Day 2010	23rd Day 2010	24th Day 2010
24th Day 2010	24th Day 2010	25th Day 2010
25th Day 2010	25th Day 2010	26th Day 2010
26th Day 2010	26th Day 2010	27th Day 2010
27th Day 2010	27th Day 2010	28th Day 2010
28th Day 2010	28th Day 2010	29th Day 2010
29th Day 2010	29th Day 2010	30th Day 2010
30th Day 2010	30th Day 2010	31st Day 2010
31st Day 2010	31st Day 2010	1st Day 2011
1st Day 2011	1st Day 2011	2nd Day 2011
2nd Day 2011	2nd Day 2011	3rd Day 2011
3rd Day 2011	3rd Day 2011	4th Day 2011
4th Day 2011	4th Day 2011	5th Day 2011
5th Day 2011	5th Day 2011	6th Day 2011
6th Day 2011	6th Day 2011	7th Day 2011
7th Day 2011	7th Day 2011	8th Day 2011
8th Day 2011	8th Day 2011	9th Day 2011
9th Day 2011	9th Day 2011	10th Day 2011
10th Day 2011	10th Day 2011	11th Day 2011
11th Day 2011	11th Day 2011	12th Day 2011
12th Day 2011	12th Day 2011	13th Day 2011
13th Day 2011	13th Day 2011	14th Day 2011
14th Day 2011	14th Day 2011	15th Day 2011
15th Day 2011	15th Day 2011	16th Day 2011
16th Day 2011	16th Day 2011	17th Day 2011
17th Day 2011	17th Day 2011	18th Day 2011
18th Day 2011	18th Day 2011	19th Day 2011
19th Day 2011	19th Day 2011	20th Day 2011
20th Day 2011	20th Day 2011	21st Day 2011
21st Day 2011	21st Day 2011	22nd Day 2011
22nd Day 2011	22nd Day 2011	23rd Day 2011
23rd Day 2011	23rd Day 2011	24th Day 2011
24th Day 2011	24th Day 2011	25th Day 2011
25th Day 2011	25th Day 2011	26th Day 2011
26th Day 2011	26th Day 2011	27th Day 2011
27th Day 2011	27th Day 2011	28th Day 2011
28th Day 2011	28th Day 2011	29th Day 2011
29th Day 2011	29th Day 2011	30th Day 2011
30th Day 2011	30th Day 2011	31st Day 2011
31st Day 2011	31st Day 2011	1st Day 2012
1st Day 2012	1st Day 2012	2nd Day 2012
2nd Day 2012	2nd Day 2012	3rd Day 2012
3rd Day 2012	3rd Day 2012	4th Day 2012
4th Day 2012	4th Day 2012	5th Day 2012
5th Day 2012	5th Day 2012	6th Day 2012
6th Day 2012	6th Day 2012	7th Day 2012
7th Day 2012	7th Day 2012	8th Day 2012
8th Day 2012	8th Day 2012	9th Day 2012
9th Day 2012	9th Day 2012	10th Day 2012
10th Day 2012	10th Day 2012	11th Day 2012
11th Day 2012	11th Day 2012	12th Day 2012
12th Day 2012	12th Day 2012	13th Day 2012
13th Day 2012	13th Day 2012	14th Day 2012
14th Day 2012	14th Day 2012	15th Day 2012
15th Day 2012	15th Day 2012	16th Day 2012
16th Day 2012	16th Day 2012	17th Day 2012
17th Day 2012	17th Day 2012	18th Day 2012
18th Day 2012	18th Day 2012	19th Day 2012
19th Day 2012	19th Day 2012	20th Day 2012
20th Day 2012	20th Day 2012	21st Day 2012
21st Day 2012	21st Day 2012	22nd Day 2012
22nd Day 2012	22nd Day 2012	23rd Day 2012
23rd Day 2012	23rd Day 2012	24th Day 2012
24th Day 2012	24th Day 2012	25th Day 2012
25th Day 2012	25th Day 2012	26th Day 2012
26th Day 2012	26th Day 2012	27th Day 2012
27th Day 2012	27th Day 2012	28th Day 2012
28th Day 2012	28th Day 2012	29th Day 2012
29th Day 2012	29th Day 2012	30th Day 2012
30th Day 2012	30th Day 2012	31st Day 2012
31st Day 2012	31st Day 2012	1st Day 2013
1st Day 2013	1st Day 2013	2nd Day 2013
2nd Day 2013	2nd Day 2013	3rd Day 2013
3rd Day 2013	3rd Day 2013	4th Day 2013
4th Day 2013	4th Day 2013	5th Day 2013
5th Day 2013	5th Day 2013	6th Day 2013
6th Day 2013	6th Day 2013	7th Day 2013
7th Day 2013	7th Day 2013	8th Day 2013
8th Day 2013	8th Day 2013	9th Day 2013
9th Day 2013	9th Day 2013	10th Day 2013
10th Day 2013	10th Day 2013	11th Day 2013
11th Day 2013	11th Day 2013	12th Day 2013
12th Day 2013	12th Day 2013	13th Day 2013
13th Day 2013	13th Day 2013	14th Day 2013
14th Day 2013	14th Day 2013	15th Day 2013
15th Day 2013	15th Day 2013	16th Day 2013
16th Day 2013	16th Day 2013	17th Day 2013
17th Day 2013	17th Day 2013	18th Day 2013
18th Day 2013	18th Day 2013	19th Day 2013
19th Day 2013	19th Day 2013	20th Day 2013
20th Day 2013	20th Day 2013	21st Day 2013
21st Day 2013	21st Day 2013	22nd Day 2013
22nd Day 2013	22nd Day 2013	23rd Day 2013
23rd Day 2013	23rd Day 2013	24th Day 2013
24th Day 2013	24th Day 2013	25th Day 2013
25th Day 2013	25th Day 2013	26th Day 2013
26th Day 2013	26th Day 2013	27th Day 2013
27th Day 2013	27th Day 2013	28th Day 2013
28th Day 2013	28th Day 2013	29th Day 2013
29th Day 2013	29th Day 2013	30th Day 2013
30th Day 2013	30th Day 2013	31st Day 2013
31st Day 2013	31st Day 2013	1st Day 2014
1st Day 2014	1st Day 2014	2nd Day 2014
2nd Day 2014	2nd Day 2014	3rd Day 2014
3rd Day 2014	3rd Day 2014	4th Day 2014
4th Day 2014	4th Day 2014	5th Day 2014
5th Day 2014	5th Day 2014	6th Day 2014
6th Day 2014	6th Day 2014	7th Day 2014
7th Day 2014	7th Day 2014	8th Day 2014
8th Day 2014	8th Day 2014	9th Day 2014
9th Day 2014	9th Day 2014	10th Day 2014
10th Day 2014	10th Day 2014	11th Day 2014
11th Day 2014	11th Day 2014	12th Day 2014
12th Day 2014	12th Day 2014	13th Day 2014
13th Day 2014	13th Day 2014	14th Day 2014
14th Day 2014	14th Day 2014	15th Day 2014
15th Day 2014	15th Day 2014	16th Day 2014
16th Day 2014	16th Day 2014	17th Day 2014
17th Day 2014	17th Day 2014	18th Day 2014
18th Day 2014	18th Day 2014	19th Day 2014
19th Day 2014	19th Day 2014	20th Day 2014
20th Day 2014	20th Day 2014	21st Day 2014
21st Day 2014	21st Day 2014	22nd Day 2014
22nd Day 2014	22nd Day 2014	23rd Day 2014
23rd Day 2014	23rd Day 2014	24th Day 2014
24th Day 2014	24th Day 2014	25th Day 2014
25th Day 2014	25th Day 2014	26th Day 2014
26th Day 2014	26th Day 2014	27th Day 2014
27th Day 2014	27th Day 2014	28th Day 2014
28th Day 2014	28th Day 2014	29th Day 2014
29th Day 2014	29th Day 2014	30th Day 2014
30th Day 2014	30th Day 2014	31st Day 2014
31st Day 2014	31st Day 2014	1st Day 2015
1st Day 2015	1st Day 2015	2nd Day 2015
2nd Day 2015	2nd Day 2015	3rd Day 2015
3rd Day 2015	3rd Day 2015	4th Day 2015
4th Day 2015	4th Day	

5 Press 'MENU' and press ◀ or ▶ to select 'SETUP'.

6 Press ▲ or ▼ to select 'DTV Manual Tuning' and press **OK** to enter the submenu.

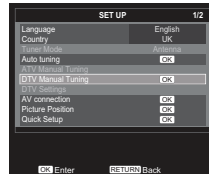

7 Press ▲ or ▼ to select 'RF Channel'. Press ◀ or ▶ to change the RF channel or directly input using the number key pad on the remote.

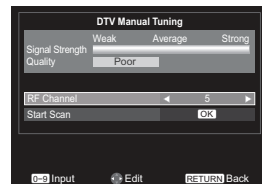

8 Press ▲ or ▼ to select 'Start Scan' and press **OK** to start tuning.

9 Press the 'Menu' button or 'EXIT'. You should find that you now have your preferred service installed.



If you need any more help, contact your retailer, installer, manufacturer or the Digital UK helpline on 08456 50 50 50 *

digitaluk

The Remote Control

Simple at-a-glance reference of your remote control.

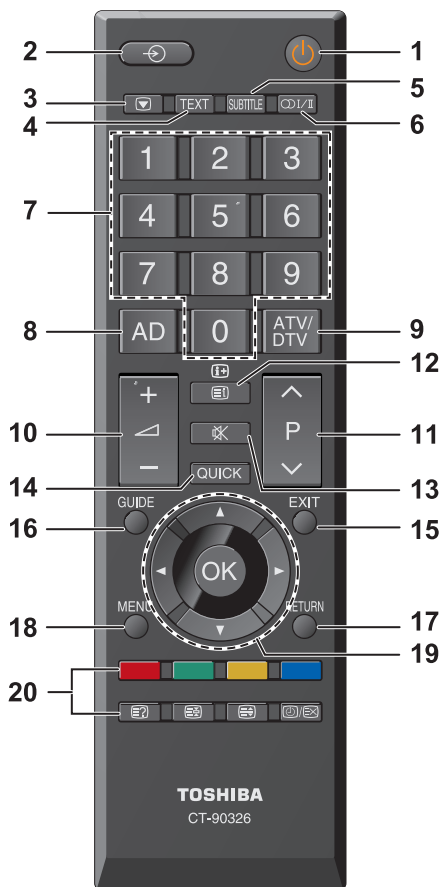

- 1 Toggle between TV ON or Standby
- 2 Toggle between external input sources
- 3 Still Picture
- 4 To display the teletext screen
- 5 TEXT subtitle pages if available
- 6 Stereo/Bilingual transmissions
- 7 Number buttons
- 8 Audio Description
- 9 Switch between ATV and DTV
- 10 Change the volume
- 11 Change the channel

- 12 In TV mode: Display on-screen information
In Text mode: Access the index page
- 13 Mute the sound
- 14 Display the QUICK access menu
- 15 Exit the menu system
- 16 Display EPG
- 17 Go to the previous level of the menu
- 18 Display the on-screen menu
- 19 Menu navigation: ▲, ▼, ◀, ▶:
In Text mode: Change the page
⊙ Confirm the selection
- 20 Colour button: Text control buttons
⊞ Reveal concealed text
⊞ Hold a wanted page
⊞ Enlarge text display size
⊞ Select a page while viewing a normal picture

Inserting batteries and effective range of the remote

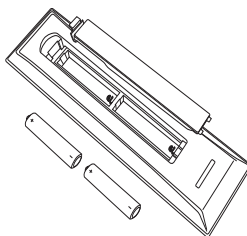

Remove the back cover to reveal the battery compartment and make sure the batteries are inserted the right way round. Suitable battery types for this remote are AAA, 1.5V.

Do not combine a used, old battery with a new one or mix battery types. Remove dead batteries immediately to prevent acid from leaking into the battery compartment. Dispose of them in accordance with instructions on page 64 of this manual. Warning: batteries must not be exposed to excessive heat such as sunlight or fire.

The performance of the remote control will deteriorate beyond a distance of five metres or outside an angle of 30 degrees from the centre of the television. If the operating range becomes reduced the batteries may need replacing.

Connecting External Equipment

Before connecting any external equipment, turn off all main power switches. If there is no switch remove the mains plug from the wall socket.

Connect the power cord into the AC-IN socket found at the back of the TV.

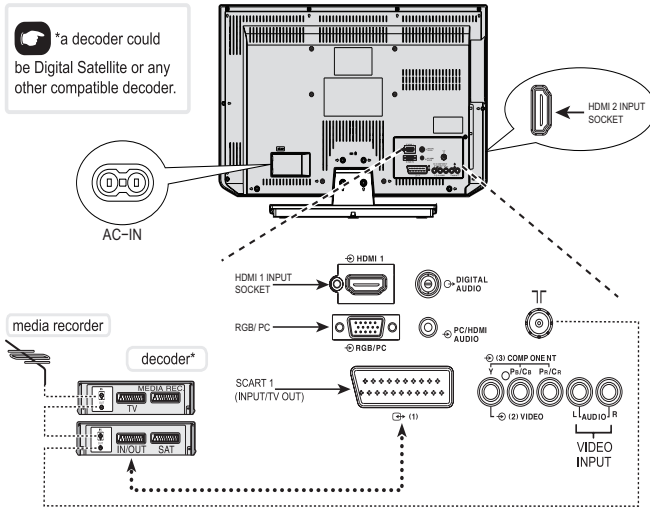

For 26/32EL83*B | 32/42HL83*B

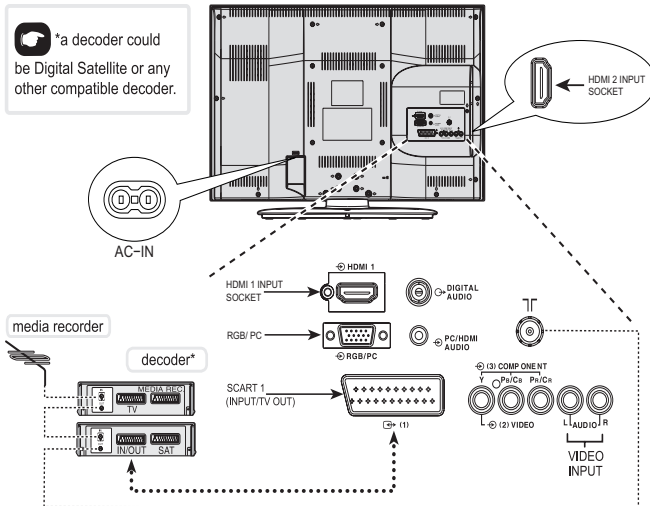

For 32AV83*B | 32/40LV83*B

Aerial cables: -----

Connect the aerial to the ANT socket on the rear of the television.

If you use a decoder and/or media recorder, connect through the decoder and/or media recorder to the television.

SCART cables: -----

Connect the video recorder **IN/OUT** or decoder **TV** socket to the television. Connect the media player **SAT** socket to the decoder **MEDIA REC.** socket.

Before running **Auto Tuning** put your decoder and media recorder to **Standby**.

HDMI® (High-Definition Multimedia Interface) is for use with a DVD, decoder or electrical equipment with digital audio and video output. It is designed for best performance with 1080i high-definition video signals but will also accept and display 480i, 480p, 576i, 576p, 720p and 1080p. HDMI1 also support VGA, SVGA, XGA, WXGA and SXGA.

NOTE: Although this television is able to connect to HDMI equipment it is possible that some equipment may not operate correctly.

A wide variety of external equipment can be connected to the back of the television, therefore the relevant owners manuals for all additional equipment must be referred to.

If the television automatically switches over to monitor external equipment, return to normal television by pressing the desired channel button. To recall external equipment, press  to select.

HDMI, the HDMI Logo, and High-Definition Multimedia Interface are trademarks or registered trademarks of HDMI Licensing LLC in the United States and other countries.

NOTE: Because there is possibility to happen unexpected phenomenon, power cord should not be disconnected frequently.

HDMI-LINK Connections

The basic functions of connected audio/video equipment can be controlled using the television's remote control if a HDMI-LINK compatible device is connected.

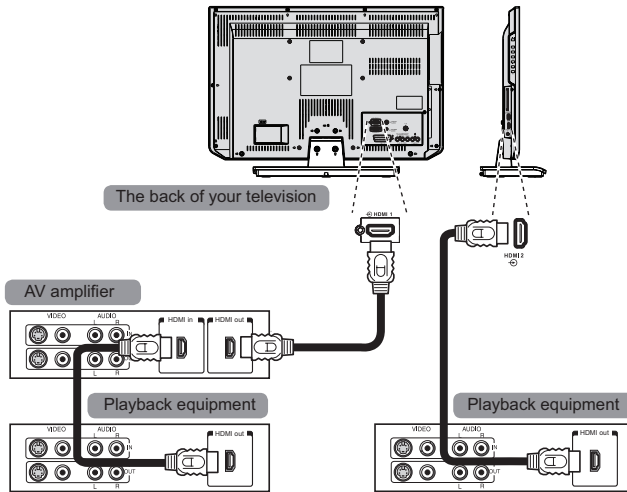

For 26/32EL83*B | 32/42HL83*B

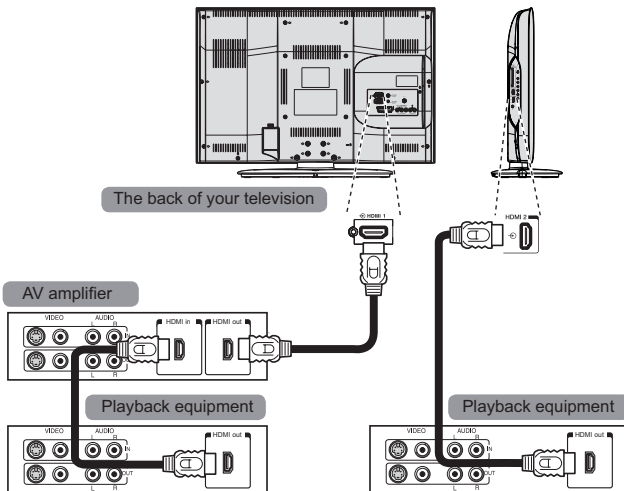

For 32AV83*B | 32/40LV83*B

Connecting an HDMI or DVI device to the HDMI input

The HDMI input on your television receives digital audio and uncompressed digital video from an HDMI source device or uncompressed digital video from a DVI (Digital Visual Interface) source device. This input is designed to accept HDCP (High-Bandwidth Digital-Content Protection) programme material in digital form from EIA/CEA-861-D-compliant [1] consumer electronic devices (such as a set-top box or DVD player with HDMI or DVI output). For acceptable video signal formats, see page 22.

NOTE:

- Some early HDMI equipment may not work properly with your latest HDMI TV, due to the adoption of a new standard.
- Supported Audio format: Linear PCM, sampling rate 32/44.1/48kHz.

To connect an HDMI device

Connect an HDMI cable (type A connector) from the device to the HDMI terminal. For proper operation, it is recommended that you use an HDMI cable with the HDMI Logo (**HDMI**).

- If your HDMI connection is capable of 1080p and/or your television is capable of refresh rates greater than 50Hz, you will need a Category 2 cable. Conventional HDMI/DVI cable may not work properly with this mode.
- HDMI cable transfers both video and audio. Separate analogue audio cables are not required (see illustration).

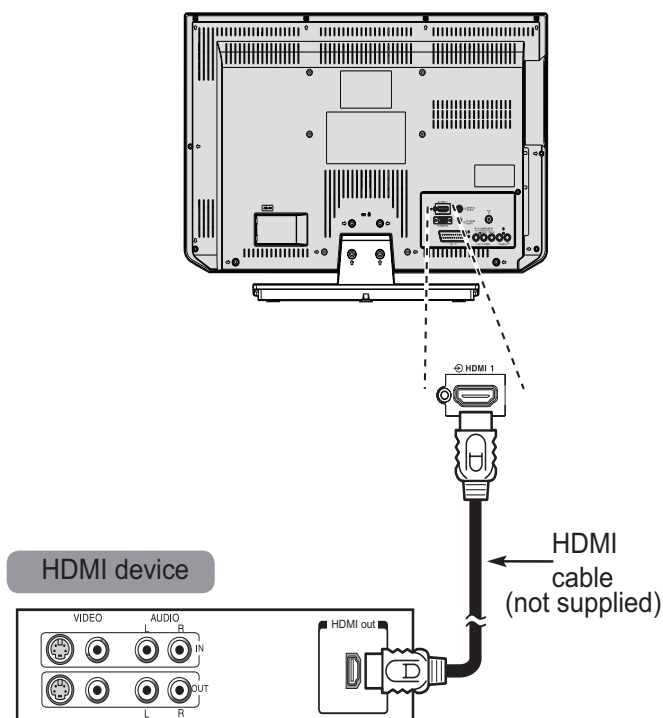

For 26/32EL83*B | 32/42HL83*B

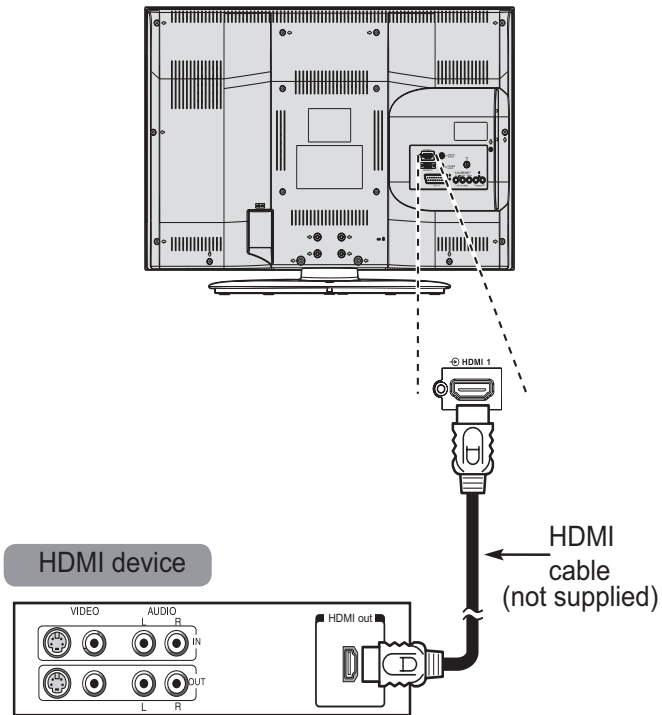

For 32AV83*B | 32/40LV83*B

To view the HDMI device video, press the  button to select HDMI 1 or HDMI 2 mode.

To connect a DVI device

Connect an HDMI-to-DVI adapter cable (HDMI type A connector) to the HDMI 1 terminal and audio cables to the PC/HDMI1 (AUDIO) socket (see illustration).

- The recommended HDMI-to-DVI adapter cable length is 6.6ft (2m).
- An HDMI-to-DVI adapter cable transfers video only.
- Separate analogue audio cables are required for audio receivers.

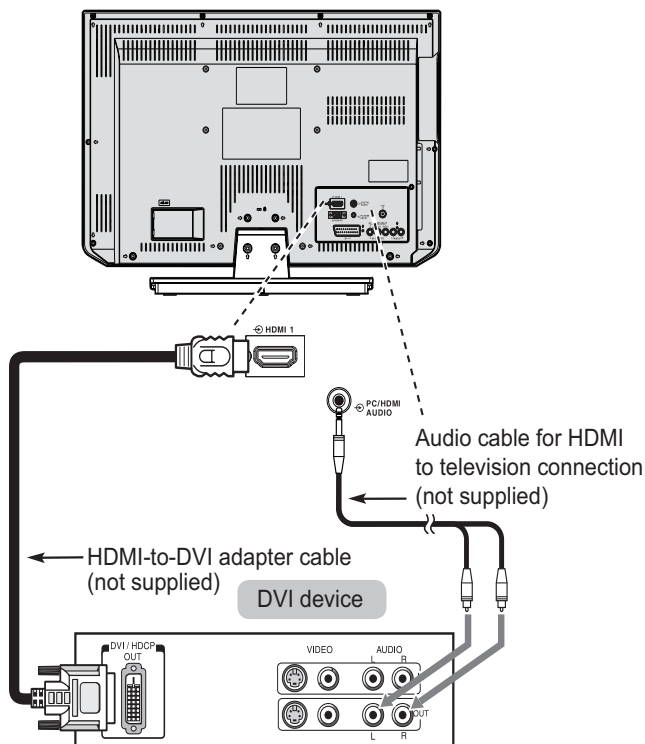

For 26/32EL83*B | 32/42HL83*B

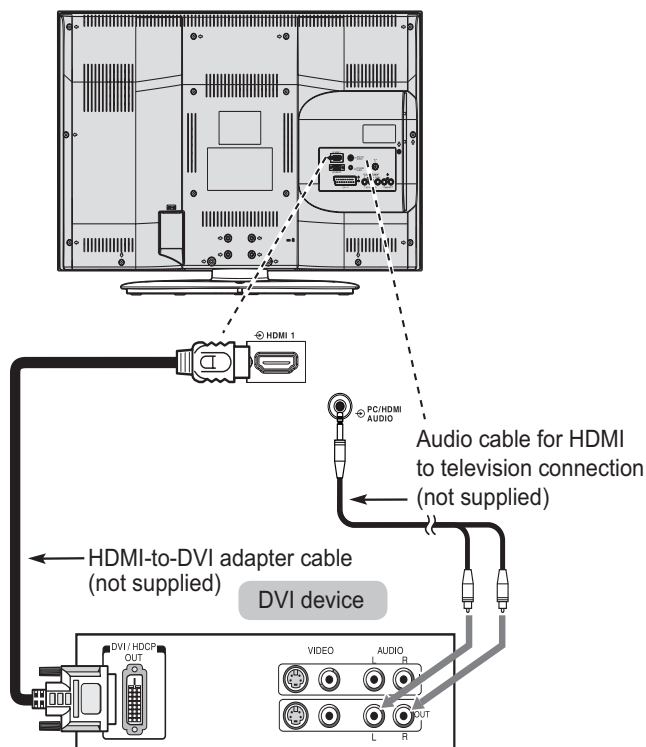

For 32AV83*B | 32/40LV83*B

To ensure that the HDMI or DVI device is reset properly, it is recommended that you follow these procedures:

- When turning on your electronic components, turn on the television first, and then the HDMI or DVI device.
- When turning off your electronic components, turn off the HDMI or DVI device first, and then the television.

[1] EIA/CEA-861-D compliance covers the transmission of uncompressed digital video with high-bandwidth digital content protection, which is being standardized for reception of high-definition video signals. Because this is an evolving technology, it is possible that some devices may not operate properly with the television.

HDMI, the HDMI Logo, and High-Definition Multimedia Interface are trademarks or registered trademarks of HDMI Licensing LLC in the United States and other countries.

Connecting a Computer

With either an RGB/PC or an HDMI connection, you can watch your computer's display on the television and hear the sound from the television's speakers.

To connect a PC to the HDMI terminal

When connecting a PC to the HDMI terminal on the television, use an HDMI-to-DVI adapter cable and an analogue audio cable.

If connecting a PC with an HDMI terminal, use an HDMI cable (type A connector). A separate analogue cable is not necessary.

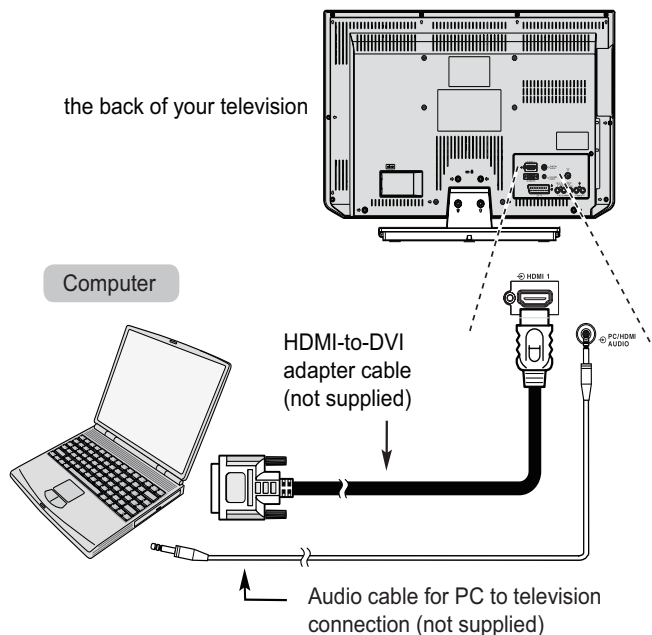

For 26/32EL83*B | 32/42HL83*B

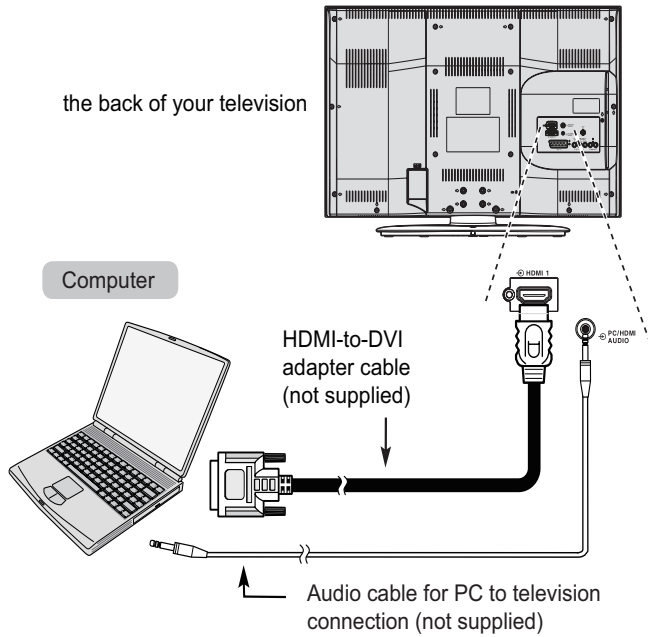

For 32AV83*B | 32/40LV83*B

For acceptable PC and video signal formats, see page 22.

NOTE:

- The edges of the images may be hidden.
- If connecting a certain PC model with a unique PC signal, the PC signal may not be detected correctly.

Acceptable Video signals through HDMI terminals

Resolution	H. Frequency (KHz)	V. Frequency (Hz)
480i	15.734	60.000
480p	31.500	60.000
576i	15.625	50.000
576p	31.250	50.000
720p	37.500	50.000
720p	45.000	60.000
1080i	28.125	50.000
1080i	33.750	60.000
1080p	27.000	24.000
1080p	28.125	25.000
1080p	33.750	30.000
1080p	56.250	50.000
1080p	67.500	60.000

Acceptable PC signals through HDMI terminals

Resolution	H (KHz)	V(Hz)	Pixel Clock (MHz)	H-Polarity	V-Polarity	H-Total	V-Total
640 x 480	31.369	59.940	25.175	Negative	Negative	800	525
640 x 480	37.861	72.809	31.500	Negative	Negative	832	520
640 x 480	37.500	75.000	31.500	Negative	Negative	840	500
800 x 600	35.160	56.250	36.000	Positive	Positive	1024	625
800 x 600	37.879	60.317	40.000	Positive	Positive	1056	628
800 x 600	48.077	72.188	50.000	Positive	Positive	1040	666
800 x 600	46.875	75.000	49.500	Positive	Positive	1056	625
1024 x 768	48.363	60.004	65.000	Negative	Negative	1344	806
1024 x 768	60.023	75.029	78.750	Positive	Positive	1312	800
1280 x 768	47.776	59.870	79.500	Negative	Positive	1664	798
1360 x 768	47.712	60.015	85.500	Positive	Positive	1792	795
1280 x 1024	63.981	60.020	108.000	Positive	Positive	1688	1066
1280 x 1024	79.976	75.025	135.000	Positive	Positive	1688	1066

Digital On-Screen Information and Programme Guide

When viewing in digital mode, the on-screen information and programme guide provide access to programme details for all available channels.

Information

- 1 Press **i+**, and the information screen will appear giving details of the channel and programme currently being viewed.

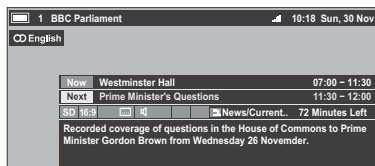

- 2 Press **▲** or **▼** to choose from **Now** or **Next** information guide.

On-Screen Information Icons

Icons will appear on the Information screen giving details about the programmes being broadcast. Details of these icons are listed below:

	Icon	Description
Service info		Service type (TV, Radio, TEXT)
		Skip
Audio info		Mono
		Stereo
		Dual mono
		Multichannel
		Dolby Digital
		Dolby Digital+
Audio/Subtitle info		Hearing Impaired
Event info		Video format (HD, SD)
		Video Aspect
		Teletext
		Subtitle (Single, Multi)
		Multi-audio track
		Parental rating
		Encrypted
Timer info		Recording
		Reminder

Guide

- 1 Select the on-screen guide by pressing **GUIDE**. The guide screen will appear highlighting details of the channel and programme currently being viewed. This may take a few moments to appear.
- 2 Press **◀** or **▶** for information on other programmes scheduled for the channel selected.
- 3 For details of other programmes currently available, press **▲** and **▼** to scroll up and down the channel list.

NOTE: In order for the recording operation to work properly, the media recorder must be set to the same time as the TV. Regarding the process for recording, please refer to the owner's manual of the recording equipment.

Frequently Asked Questions

Q *Why is there no sound or picture?*

A Check that the television is on and that all connections are made properly.

Q *There is a picture, but why is there little or no colour?*

A The colour is factory set to **Auto** to automatically display the best colour system. When using an **external** source, if there is little or no colour, improvements may sometimes be achieved.

To manually change the colour system:

- 1 With the external source playing, select **Manual setting** in the **SETUP** menu.
- 2 Using **▲** or **▼** to choose from **Auto**, **NTSC 4.43**, **NTSC 3.58**, **SECAM** or **PAL**.

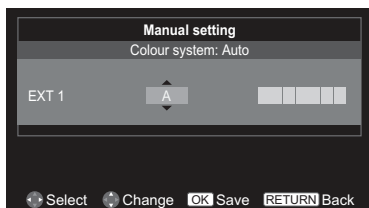

Q *Why doesn't the video/DVD being played show on-screen?*

A Make sure the VCR or DVD player is connected to the television, then select the correct input by pressing **↻**.

Q *Why is there a good picture but no sound?*

A Check all cable connections and that the volume has not been turned down or that the sound has not been muted.

Q *What else can cause a poor picture?*

A Interference or a weak signal. Try a different television station. Manual fine tuning may help:

- 1 Select the **ATV/DTV Manual Tuning** in the **SETUP** menu. Highlight the station and press **OK**, then press **◀** or **▶** to select **Manual fine tuning**.

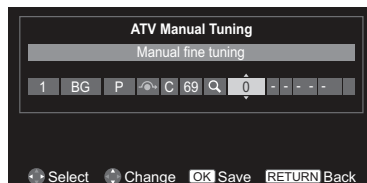

- 2 Using **▲** or **▼** to adjust to get the best picture and sound. Press **OK** and then **EXIT**.

Q *Why doesn't the remote control work?*

A Check that the batteries aren't dead or inserted incorrectly.

Q *Why are there problems with text?*

A Good performance of text depends on a strong broadcast signal. If the text is unreadable or garbled, check the aerial, satellite or cable connection. Go to the main index page of the text service and look for the User Guide. This will explain the basic operation of text in some detail.

Q *Why are the four coloured text numbers visible but no text?*

A Text has been selected while viewing an external source. No text will appear on-screen or a box may appear stating no information is available. Select a broadcasting channel and press **⏏** to access.

Q Why are the colours wrong when an NTSC source is played?

A Connect the source via a SCART cable and play. Select **Manual setting** from the **SETUP** menu and set the Colour System to Auto.

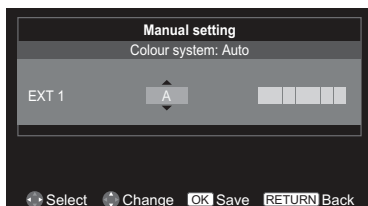

Q What can be done if the user-defined password has been forgotten?

A Use the universal password 1276, then change to a new number of your choice.

Q Why don't the devices connected via HDMI operate properly?

A Make sure to use cables with the HDMI logo (**HDMI**[®]). Some early HDMI equipment may not work properly with the latest HDMI TV products, due to adoption of new standards.

Q Why is the VCR/DVD picture in black and white?

A Check the correct input has been chosen: S-VIDEO or AV.

Q Why did TV turn off by itself?

A After roughly 15 minutes without any input video signal at TV mode, the TV will turn off to save power.

Using the Controls

While all the necessary adjustments and controls for the television are made using the remote control, the buttons on the television may be used for some functions.

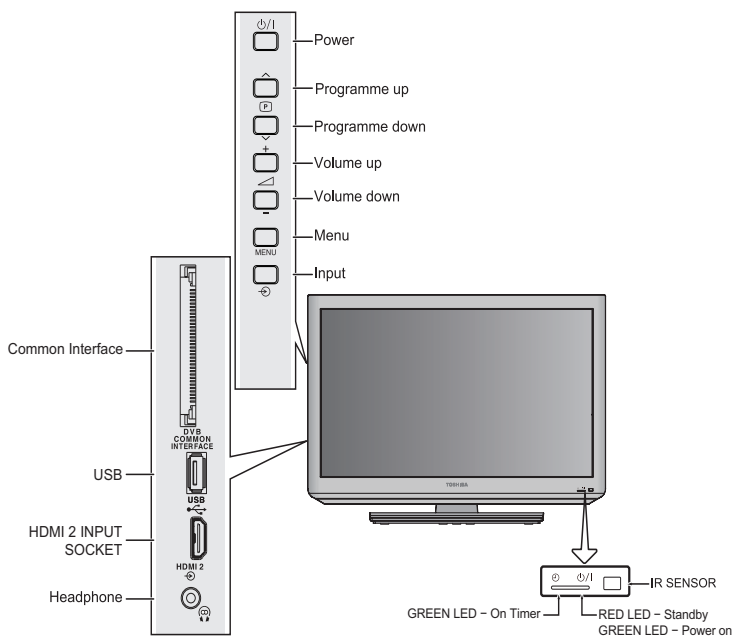

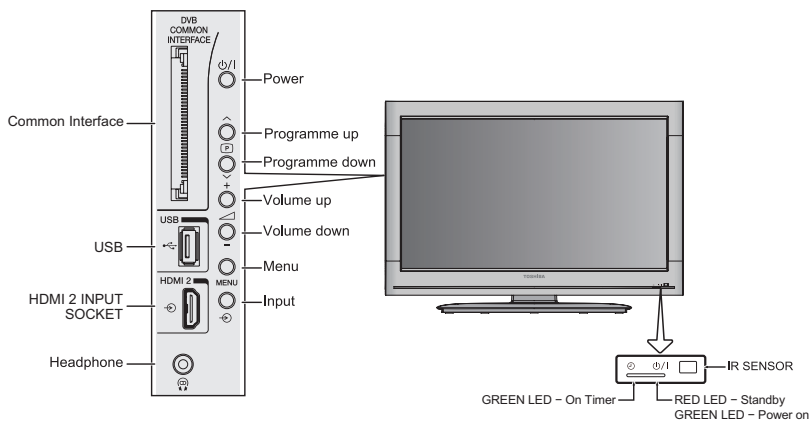

For 26/32EL83*B | 32/42HL83*B



For 32AV83*B | 32/40LV83*B

Switching On





If the RED LED is unlit check that the plug is connected to the power supply. If the picture does not appear press  on the remote control, it may take a few moments.

To put the television into Standby press  on the remote control. To view the television press  again. The picture may take a few seconds to appear.

Using the Remote Control

To set up the television you will now need to use the on screen menus. Press **MENU** on the remote control to see the menus.

The on-screen menu appears as a list of five topics. As each symbol is selected by pressing  or  on the navigation ring on the remote control, its respective options will appear right side.

To use the options, press  to enter the sub menu. Then press  or  on the navigation ring to move up and down through them and use  or to select the required choice. Follow the on-screen instructions. The functions of each menu are described in detail throughout the manual.

Using the Side-Key Controls

To change the volume, press  .

To alter the channel, press  **P** .

Press **MENU** and , ,  or  to control the sound and picture options.

Press **MENU** to finish.

To select an external input, press  and then use  or  to move through the list until the appropriate input source is selected.

Please always refer to the owner's manual of the equipment to be connected for full details.

Please note: Inserting the headphone plug will mute the sound from all speakers.

Tuning the Television







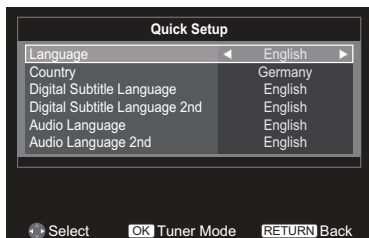













Before switching on the television put your decoder and media recorder to **Standby** if they are connected. To set up the television use the buttons on the remote control as detailed on page 12.

Quick Setup

- 1 For first time use, plug in the television and press the  button. The **Quick Setup** screen will appear.



Note: The **Quick Setup** menu can also be accessed in the **SETUP** menu.



- 2 Press  or  to select **Language** and then press  or  to select your language (English, Français, Deutsch, Español, Italiano, Português, Nederlands, Svenska, Dansk, Norsk, Suomi, Polski, Slovenščina, Magyar, Slovensky, Český, Русский, Română, Български, Срpski, Ελληνικά, Hrvatski, Türkçe or Українська).
- 3 Press  or  to select **Digital Subtitle Language** and then press  or  to select your preferred language.
- 4 Press  or  to select **Digital Subtitle Language 2nd** and then press  or  to select your preferred language.
- 5 Press  or  to select **Audio Language** and then press  or  to select your preferred language.
- 6 Press  or  to select **Audio Language 2nd** and then press  or  to select your preferred language.

- 7 Press  or  to select **Country** and then press  or  to select your country (UK, Italy, Netherlands, Sweden, Bulgaria, Greece, Russia, Norway, Ireland, Portugal, Others, Austria, Belgium, Switzerland, Czech, Germany, Denmark, Spain, Finland, France, Poland, Turkey, Hungary, Slovenia, Ukraine, Slovakia, Luxembourg or Romania).

Press  to select **Tuner Mode**.

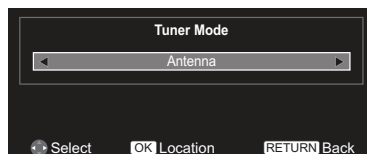
NOTE: This option is country specific in the **Quick Setup** menu



Press  or  to select **Antenna** or **Cable**.

- 8 Press  to select **Location**.

NOTE: The **Location** can also be accessed in the **SETUP** menu.



Press  or  to select **Home** or **Store**.

When **Store** is selected, the confirmation window appears.

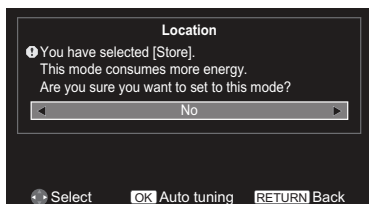

Press ◀ or ▶ to select **Yes** or **No**.

- 9 Press **OK** to enter the **Auto tuning** menu.

NOTE: Please make sure the aerial is connected to the TV before tuning.

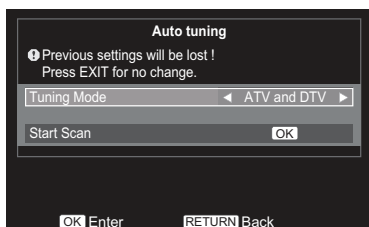

Press ▲ or ▼ to select **Tuning Mode** and then press ◀ or ▶ to select **ATV**, **DTV** or **ATV and DTV**.

Press ▲ or ▼ to select **Start Scan** and press **OK**.

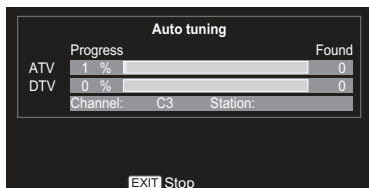

The search will begin for all available stations. The slide bar will move along the line as the search progresses.

You must allow the television to complete the search.

When the search is complete the television will automatically select channel 1. This may not be a clear picture or the signal may be weak, so the station order can be changed using **ATV/DTV Manual Tuning** in the **SETUP** menu.

NOTE: The time will be set automatically by transmission but can be advanced or decreased by using **Local Time Setting** in the **DTV Settings** screen.

Setting the Channels

Note: When **Parental Block** is activated, the 4-digit password is needed.

Auto Tuning

The **Auto tuning** function will completely re-tune the television and can be used to update the channel list.

NOTE: It is recommended that **Auto tuning** is run periodically to ensure that all new services are added.

NOTE: All the current channels and settings, for example, the locked channels, will be lost.

Tuner Mode - Antenna

- 1 Press **MENU**. Press ◀ or ▶ to select **SETUP** and press **OK** to enter the sub-menu..



- 2 Press ▲ or ▼ to select **Auto tuning**, and press **OK** to enter the submenu.

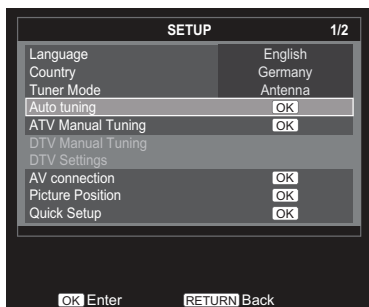

- 3 Press ▲ or ▼ to select **Tuning Mode** and press ◀ or ▶ to select **ATV, DTV** or **ATV and DTV**.

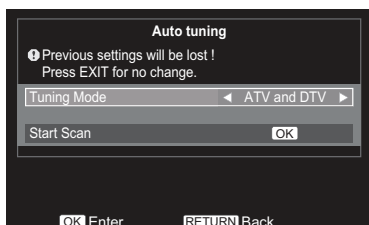

Press ▲ or ▼ to select **Start Scan** and press **OK** to start **Auto Tuning**.

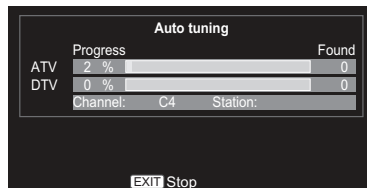

Tuner Mode - Cable

Switching between tuner modes will change the features available on your television.

All the current channels and settings, for example, the locked channels, will be lost.

In the **SETUP** menu, press ▲ or ▼ to select **Tuner Mode** and press **OK**.

Press ◀ or ▶ to select **Yes** or **No**.

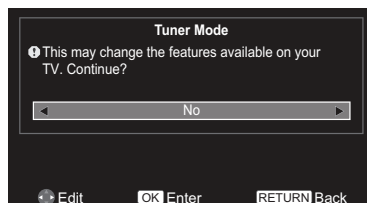

- 1 Press **MENU**. Press ◀ or ▶ to select **SETUP** and press **OK** to enter the sub-menu..
- 2 Press ▲ or ▼ to select **Auto tuning**, and press **OK** to enter the submenu.

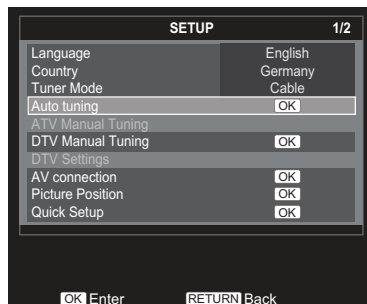

- 3 Press ▲ or ▼ to select **Tuning Mode** and press ◀ or ▶ to select **ATV, DTV** or **ATV and DTV**.

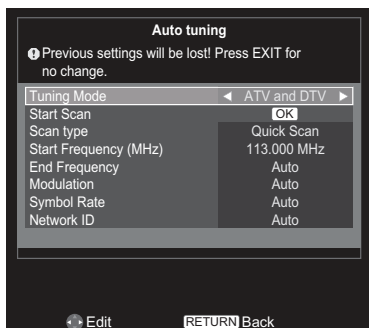

- 4 Press ▲ or ▼ to select **Operator Selection**, and press ◀ or ▶ to select **Others**, **Ziggo** or **UPC**.

NOTE: **Operator Selection** can only be adjusted when **Country** is **Netherlands**.

- 5 Press ▲ or ▼ to select **Scan type**, and press ◀ or ▶ to select **Full Scan** or **Quick Scan**.

NOTE: Channels with a weak signal may be missed by **Quick Scan**.

- 6 Press ▲ or ▼ to select **Operator Start Frequency, End Frequency, Modulation, Symbol Rate** or **Network ID**, and use number key pad on the remote to define the information or select **Auto** for tuning.

Press ▲ or ▼ to select **Start Scan** and press OK to start tuning.

NOTE:

- The information should be given by your cable provider.
- **Network ID** is only available for **Quick Scan**.

Manual Tuning

There are two TV modes: ATV and DTV that can be tuned-in manually using **Manual Tuning**.

ATV mode - Antenna/Cable

- 1 Press **MENU**. Press ◀ or ▶ to select **SETUP** and press OK to enter the submenu.
- 2 Press ▲ or ▼ to select **ATV Manual Tuning** and press OK to enter the submenu.

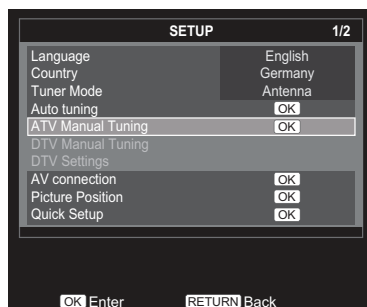

- 3 Press ▲ or ▼ to select the programme position you want to arrange and then press ▶.

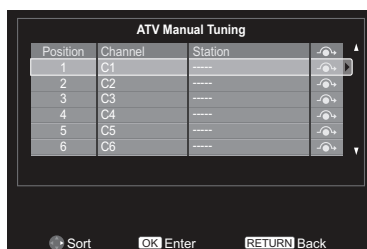

- 4 Press ▲ or ▼ to move through the list to your preferred position. As you do so the other stations will move to make room. Press ◀ to store programme position.

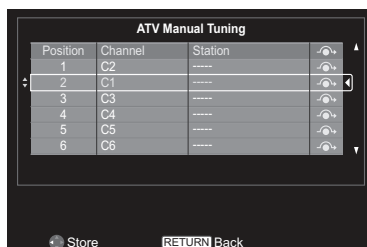

- 5 Press **OK** to display the breakdown menu. Press **◀** or **▶** to select an item, then press **▲** or **▼** to select the item as shown below.

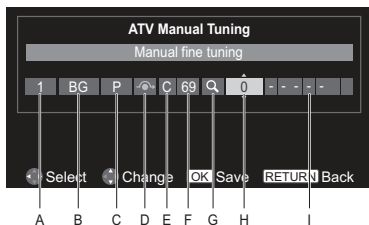

- A Position:**
The number to be pressed on the remote control.
- B System:**
Specific to certain areas.
- C Colour system:**
Factory set to Auto, should only be changed if problems are experienced, i.e. NTSC input from external source.
- D Skip:**
👁 Means nothing has been stored or the facility to skip the channel is **On**.
- E Signal Class:**
The channel classification.
- F Channel:**
The channel number on which a station is being broadcast.
- G Searching:**
Search up and down for a signal.
- H Manual fine tuning:**
Turn on to execute fine tune function.
Turn off to execute manual fine tune function.
- I Station:**
Station identification. Use the **▲** or **▼** and **◀** or **▶** buttons to enter up to seven characters.
- 6 Press **OK** to save.

DTV mode - Antenna

- 1 Press **MENU**. Press **◀** or **▶** to select **SETUP** and press **OK** to enter the submenu..
- 2 Press **▲** or **▼** to select **DTV Manual Tuning** and press **OK** to enter the submenu.

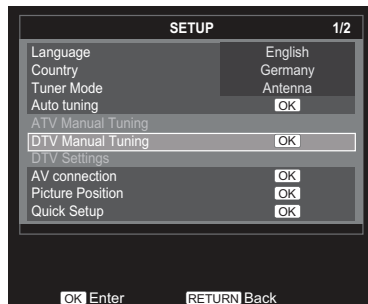

- 3 Press **▲** or **▼** to select **RF Channel** and press **◀** or **▶** to select or use number key pad on the remote to enter a channel.

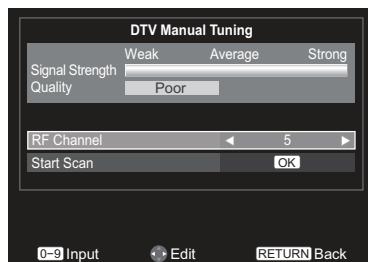

- 4 Press **▲** or **▼** to select **Start Scan** and press **OK** to start tuning.

DTV mode - Cable

- 1 Press **MENU**. Press ◀ or ▶ to select **SETUP** and press **OK** to enter the sub-menu..
- 2 Press ▲ or ▼ to select **DTV Manual Tuning** and press **OK** to enter the submenu.

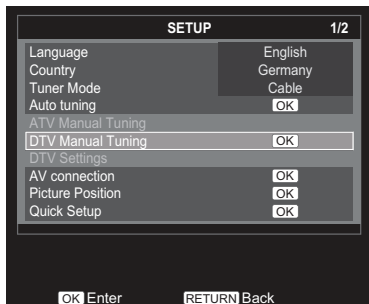

- 3 Press ▲ or ▼ to select **Frequency**, **Modulation** or **Symbol Rate**, and use number key pad on the remote to define the information or select **Auto** for tuning.

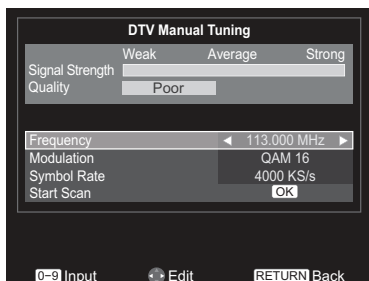

Press ▲ or ▼ to select **Start Scan** and press **OK** to start tuning.

Automatic Power Down

The TV will automatically turn itself off (standby) within 4 hours, if you do not touch the control buttons on the remote control or on the TV control panel. It will also automatically turn off if no input signal is detected after approximately 15 minutes.

- 1 In the **SETUP** menu, press ▲ or ▼ to select **Automatic Power Down**.
- 2 Press ◀ or ▶ to select **On** or **Off**.

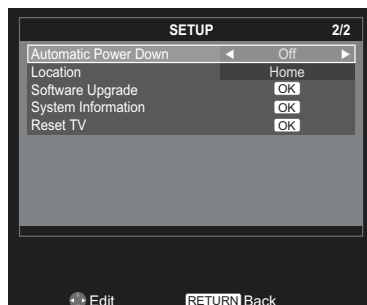

Reset TV

Selecting **Reset TV** will reset all TV settings to their original factory values.

- 1 In the **SETUP** menu, press ▲ or ▼ to select **Reset TV** and press **OK**.
- 2 Press ◀ or ▶ to select **Yes** to confirm or select **No** to exit and press **OK**.

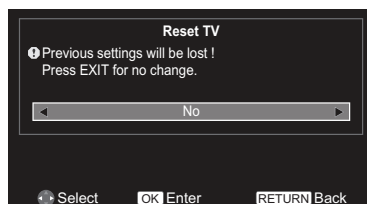

DTV Settings

Channels

The channel order may be changed to suit your personal preference.

NOTE: This function is only available in DTV mode.

- 1 Press **MENU**. Press ◀ or ▶ to select **SETUP** and press **OK** to enter the sub-menu.



- 2 Press ▲ or ▼ to select **DTV Settings** and press **OK** to enter the submenu.
- 3 Press ▲ or ▼ to select **Channels** and press **OK**.

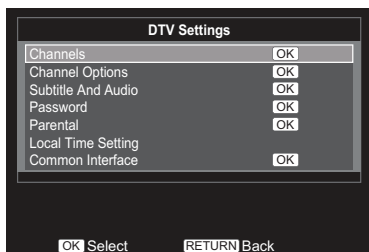

- 4 Press ▲ or ▼ to select **Channels**.

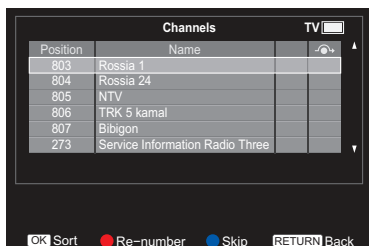

Re-number

- 5 Press the **RENUMBER** button on the remote to renumber the highlighted channel.
- 6 Edit the channel number using the number keys on the remote and press **OK**.

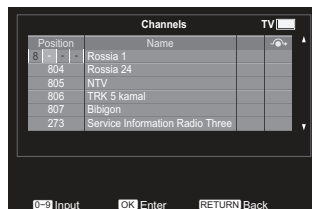

Skip

- 7 Press the **SKIP** button on the remote. A icon appears.

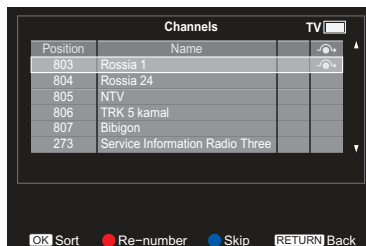

Sort

- 8 Press ▲ or ▼ to select the desired channel and then press **OK**. A tick icon appears.

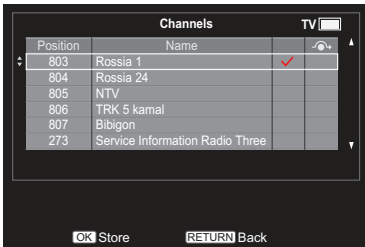

- 9 Press ▲ or ▼ to select the channel you wish to swap with the one selected in Step 8 and then press **OK**. The positions of the two channels are swapped.

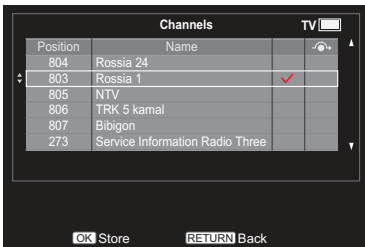

Channel Options

This function is to setup the Skip or Lock for currently watched channel.

Skip Channels

The feature allows you to set channel that will be skipped when **P ▲** or **P ▼** are used to tune.

- 1 In the **DTV Settings** menu, press ▲ or ▼ to select **Channel Options**, and press **OK** to enter the submenu.

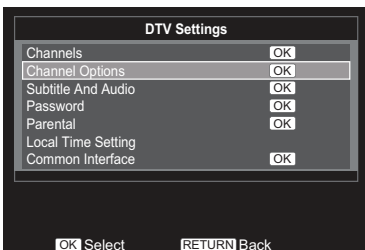

- 2 Press ◀ or ▶ to highlight the skip (⏮) box.

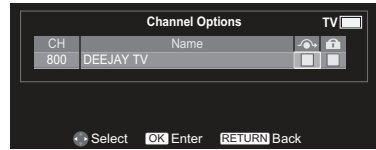

- 3 Press **OK** to select. A tick appears in the box.

NOTE: Skipped channels cannot be selected by **P ▲** or **P ▼** but still be accessed by direct entry (when tuned a ⏮ icon will be displayed in the banner to indicate as a skipped channel).

Parental Control

Locking channels stops the viewing of digital channels, and they can only be accessed by entering the password.

- 1 In the **DTV Settings** menu, press ▲ or ▼ to select **Channel Options**, and press **OK** to enter submenu.
- 2 Press ◀ or ▶ to highlight the lock (🔒) box.
- 3 Press **OK** to select. A tick appears in the box.

If the password has already been set, password entry will be required to set the locked channels.



- 4 From this point on, when any of the channels in the **Channel Options** list are selected, the password must be entered before they can be accessed.

Subtitle and Audio

You can choose the **Subtitle Type** or **Audio Type** from **Normal** or **Hearing Impaired**. If the **Hearing Impaired** is selected, it provides subtitle services to deaf and hard of hearing viewers with additional descriptions.

Subtitle Language or **Audio Language** allow a programme or film to be viewed with a choice of soundtrack language, provided they are currently being broadcast.

- 1 In the **DTV Settings** menu, press **▲** or **▼** to select **Subtitle And Audio**, and press **OK** to enter the submenu.
- 2 Press **▲** or **▼** to select **Subtitle Type** or **Audio Type** and press **◀** or **▶** to select **Normal** or **Hearing Impaired**.
- 3 Press **▲** or **▼** to select **Digital Subtitle Language**, **Digital Subtitle Language 2nd**, **Audio Language** or **Audio Language 2nd** and press **◀** or **▶** to select your preferred language.

Password

Change the 4-digit parental control password.

The factory default password is "0000".

- 1 In the **DTV Settings** menu, press **▲** or **▼** to select **Password**, and press **OK** to enter the submenu.

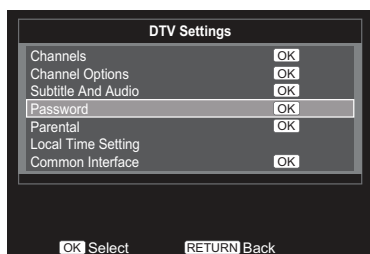

- 2 Enter a new 4-digit password, and re-enter the new password again to confirm.

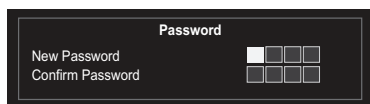

Parental

This function blocks channels or programmes that you do not want to or that you do not want your children to watch.

A password is required to access this function.

The factory default password is "0000".

NOTE: When **Parental Control** is activated, you will need to enter the 4-digit password before you enter the **DTV Settings** submenu under the **SETUP** menu. After auto tuning, all the channel blocks will be cleared.

- 1 In the **DTV Settings** menu, press **▲** or **▼** to select **Parental**, and press **OK** to enter the submenu.
- 2 Enter the 4-digit password.
- 3 Press **◀** or **▶** to set the age rating from age 4~18 or select **None** to turn this function off or **Block All**.

NOTE: This function is available for programmes with Age Rating information.

Common Interface

The Common Interface Slot, situated on the side of the television, enables the insertion of a CAM (Conditional Access Module) and card. These are purchased from a service provider and allow additional subscription broadcasts to be viewed. For information, see a service provider.

- 1 Insert the CAM and card into the Common Interface Slot, following the instructions provided with the CAM. A box will appear on the screen to confirm that the CAM has been inserted.
- 2 In the **DTV Settings** menu, press **▲** or **▼** to select **Common Interface**, and press **OK** to enter the submenu.
- 3 Details of the CAM should now be available.

NOTE: The software updating of CI Plus CAM may be automatically executed. At this time, any Recording/Reminder programme timer will be canceled.

General Controls

The General Controls will allow you to select channels and information, use the sound controls, personalise the picture style, and select external equipment.

Selecting Channels

To select a channel use the numbered buttons on the remote control.

Channels can also be selected using **P** \wedge and **P** \vee .

Stereo and Bilingual Transmissions

If stereo or dual language broadcasts are transmitted the word Stereo or Dual will appear on the screen each time channels are changed, disappearing after a few seconds. If the broadcast is not in stereo the word Mono will appear.

Stereo: Press \odot I/II to select **Stereo** or **Mono**.

Bilingual: If a bilingual programme is offered, the word **Dual** will display on screen. To change between languages, press \odot I/II to switch between **Dual 1** and **Dual 2**.

Quick Access Menu

Quick access helps you access some options quickly such as **Picture Size**, **Picture Mode**, **Sleep Timer** and **System Information**. Press the **QUICK** button to display the **Quick access** menu and use \blacktriangle or \blacktriangledown to select the option you would like to change.

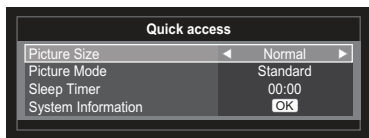

NOTE: **Quick access** items are different depending on the current mode.

Subtitles

If Subtitles are available for your current programme, pressing the **SUBTITLE** button will toggle Subtitles on or off.

Picture Still

This feature is used to hold a still image on the screen. Press \square to hold an image on the screen, press \square again to cancel.

Input Selection

Use the **Input Selection** feature if the television does not switch over automatically when using an external device.

Pressing \ominus , a list will appear on-screen showing all external equipment.

Use \blacktriangle or \blacktriangledown to highlight and \odot to select.

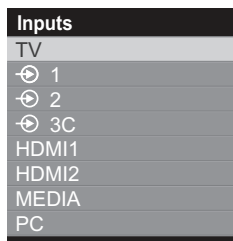

HDMI® displays equipment connected to Input HDMI on the back of the television. It is designed for best performance with 1080i/1080p high definition signals.

Sound Controls

Volume Controls and Mute Sound

Volume

Press or to adjust the volume.

Sound Mute

Press on the remote once to turn the sound off and again to cancel.

Dual

If a programme or film is being broadcast with a soundtrack in more than one language, the **DUAL** feature allows selection between them.

- 1 Press **MENU**. Press or to select **SOUND** and press to enter the submenu..



- 2 Press or to select **Dual**, and press or to choose between **Dual1** or **Dual2**.

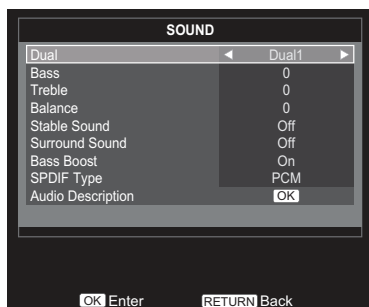

Bass, Treble and Balance

The sound controls are accessible in digital and analogue modes.

- 1 Press **MENU**. Press or to select **SOUND** and press to enter the submenu..
- 2 Press or to select **Bass, Treble** or **Balance** and press or to change the setting.

Stable Sound

The **Stable Sound** feature limits high volume levels in order to prevent the extreme changes in volume that can occur when channels are changed or a programme switches to a commercial.

- 1 Press **MENU**. Press or to select **SOUND** and press to enter the submenu..
- 2 Press or to select **Stable Sound**, and press or to select **On** or **Off**.

Surround Sound

Surround Sound enhances depth of the sound.

- 1 Press **MENU**. Press or to select **SOUND** and press to enter the submenu..
- 2 Press or to select **Surround Sound**, and press or to select **On** or **Off**.

Bass Boost

Bass Boost enhances depth of the sound.

- 1 Press **MENU**. Press or to select **SOUND** and press to enter the submenu..
- 2 Press or to select **Bass Boost**, and press or to select **On** or **Off**.

SPDIF Type

The feature allows you to select a digital audio format.

- 1 Press **MENU** and press or to select **SOUND**.
- 2 Press or to select **SPDIF Type**, and press or to select **PCM** or **Auto**.

Audio Description

Audio Description is an additional narration describing on-screen action, body language, expressions and movements for people with visual disabilities while watching the TV. This function enables you to choose the type of narrations.

- 1 Press **MENU**. Press ◀ or ▶ to select **SOUND** and press **OK** to enter the submenu..
- 2 Press ▲ or ▼ to select **Audio Description** and press **OK** to enter the submenu.
- 3 Press ▲ or ▼ to select **Audio Description**, and press ◀ or ▶ to select **On** or **Off**.

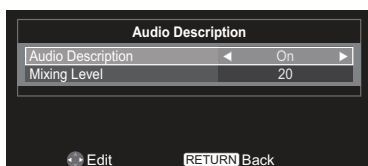

- 4 Press ▲ or ▼ to select **Mixing Level**, and press ◀ or ▶ to change the setting.

Note: **Mixing Level** can only be adjusted when **Audio Description** is **On**.

NOTE: Press the **AD** button on the remote control to switch the **Audio Description On** or **Off**.

Widescreen viewing

Depending on the type of broadcast being transmitted, programmes can be viewed in a number of formats.

Wide

Use this setting when watching a widescreen DVD, widescreen video tape or a 16:9 broadcast (when available). Due to the range of widescreen formats (16:9, 14:9, 20:9 etc.) black bars may be visible on the top and bottom of the screen.

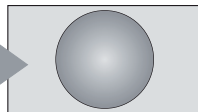

4:3

Use this setting to view a true 4:3 broadcast.

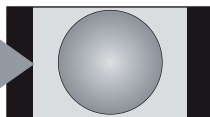

Super Live

This setting will enlarge a 4:3 image to fit the screen by stretching the image horizontally and vertically, holding better proportions at the centre of the image. Some distortion may occur.

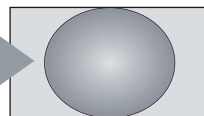

Cinema

When watching letterbox format films/video tapes, this setting will eliminate or reduce the black bars at the top and bottom of the screen by zooming in and selecting the image without distortion.

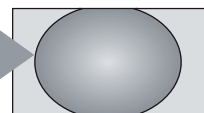

Subtitle

When subtitles are included on a letterbox format broadcast, this setting will raise the picture to ensure that all the text is displayed.

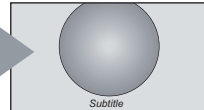

14:9

Use this setting when watching a 14:9 broadcast.

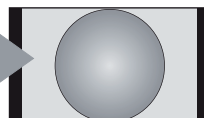

Native

When using a PC connected via HDMI this setting will show the picture without over scan, i.e. WYSIWYG.

This option is only available when watching video signal source via HDMI.

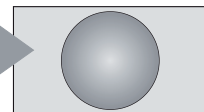

Press **QUICK** to display the **Quick access** menu. Use **▲** or **▼** to select the **Picture Size**, and press **◀** or **▶** to select the option.

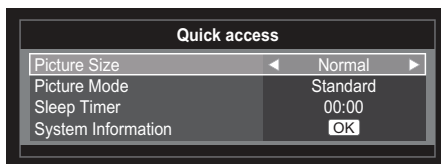

You can choose the picture size from Wide, 4:3, Super Live, Cinema, Subtitle, 14:9, Native or Normal. Using the special functions to change the size of the displayed image (i.e. changing the height/width ratio) for the purposes of public display or commercial gain may infringe on copyright laws.

Available Picture Size and Position Control

		Wide	4:3	Super Live	Cinema	Subtitle	14:9	Native	Normal	Dot by Dot
ATV		o	o	o	o	o	o	x	x	x
DTV	SD	o	o	o	o	o	o	x	x	x
	HD	o	o	o	o	x	o	o	x	x
Scart		o	o	o	o	o	o	x	x	x
CVBS		o	o	o	o	o	o	x	x	x
YPbPr	SD	o	o	o	o	o	o	x	x	x
	HD	o	o	o	o	x	x	x	x	x
HDMI	SD	o	o	o	o	o	o	o	x	x
	HD	o	o	o	o	x	x	o	x	x
D-SUB		o	x	x	x	x	x	x	o	o
DVI		o	x	x	x	x	x	x	o	o

Picture Controls

Most of the picture controls and functions are available in both **digital** and **analogue** modes.

Note: Features not available will be greyed out.

Picture Position

The Picture Position may now be adjusted to suit personal preference.

- 1 Press **MENU**. Press ◀ or ▶ to select **SOUND** and press **OK** to enter the submenu..



- 2 Press ▲ or ▼ to select **Picture Position** and press **OK** to enter the submenu.

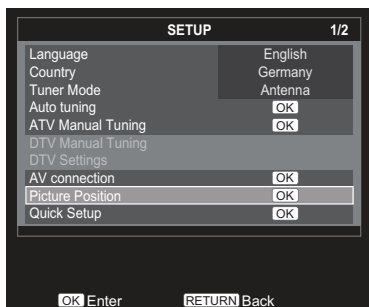

- 3 Press ▲ or ▼ to select an option you want to adjust, and press ◀ or ▶ to adjust the settings as required.

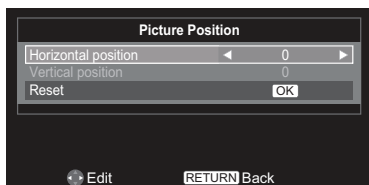

Picture Mode

You can adjust the picture appearance by selecting the preset value in picture mode based on the programme category.

- 1 Press **MENU**. Press ◀ or ▶ to select **PICTURE** and press **OK** to enter the submenu..



- 2 Press ▲ or ▼ to select **Picture Settings** and press **OK** to enter the submenu.

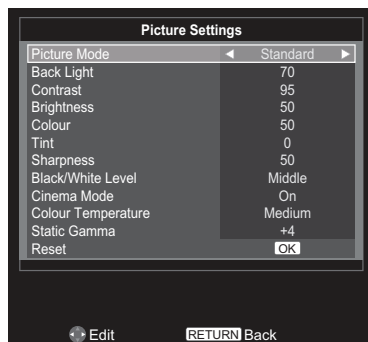

- 3 Press ▲ or ▼ to select **Picture Mode** and press ◀ or ▶ to select **Dynamic, Standard, Mild, Movie, Game** or **User**.

Note: **Game** is not available for the TV input mode.

Picture Preferences

You can customise current picture mode settings while selecting **User**.

- 1 In the **Picture Settings** menu, press ▲ or ▼ to select **Back Light, Contrast, Brightness, Colour, Tint, Sharpness**.
- 2 Press ◀ or ▶ to suit your preference.

Black/White Level

This function increases the strength of dark areas of the picture, which improves picture definition.

- 1 In the **Picture Settings** menu, press ▲ or ▼ to select **Black/White Level**.
- 2 Press ◀ or ▶ to adjust the level from **Off, Low, Middle** to **High**. The effect depends on the broadcast and is most noticeable on dark colours.

Cinema Mode

A movie film's picture runs at 24 frames a second, whereas movie software such as DVD, etc., that you enjoy watching on television at home runs at 30 (NTSC) or 25 (PAL) frames a second. To convert this signal to reproduce a smooth motion and picture quality, select the **Cinema mode**.

- 1 In the **Picture Settings** menu, press ▲ or ▼ to select **Cinema Mode**.
- 2 Press ◀ or ▶ to select **On** or **Off**.

Colour Temperature

Colour Temperature increases the 'warmth' or 'coolness' of a picture by increasing the red or blue tint.

- 1 In the **Picture Settings** menu, press ▲ or ▼ to select **Colour Temperature**.
- 2 Press ▲ or ▼ to select **Colour Temperature** and press ◀ or ▶ to select **Medium, Cool** or **Warm** to suit your preference.

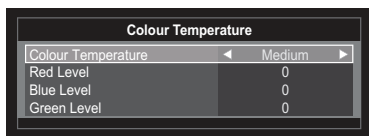

- 3 Press ▲ or ▼ to select **Red Level, Blue Level** or **Green Level** and press ◀ or ▶ to adjust the settings as required.

Static Gamma

The static gamma feature allows you to adjust the levels of black in the picture.

- 1 In the **Picture Settings** menu, press ▲ or ▼ to select **Static Gamma**.
- 2 Press ◀ or ▶ to select the number of **Static Gamma** (-5~+5).

Reset

This feature resets all picture settings to the factory settings.

In the **Picture Settings** menu, press ▲ or ▼ to select **Reset** and press ⓧ to reset settings.

NOTE: If any picture settings have not been changed, **Reset** is not available.

Active Backlight

When **Active Backlight Control** is activated, it will automatically optimise the backlighting levels for dark scenes.

- 1 Press **MENU**. Press ◀ or ▶ to select **PICTURE** and press ⓧ to enter the submenu..
- 2 Press ▲ or ▼ to select **Active Backlight Control**.
- 3 Press ◀ or ▶ to select **On** or **Off**.

3D Colour Management

When **3D Colour management** is set to **On** it allows the "Base colour adjustment" feature to become available.

You can adjust the picture colour quality by selecting from 6 base colour adjustments : **Red, Green, Blue, Yellow, Magenta** or **Cyan**.

- 1 In the **PICTURE** menu, press ▲ or ▼ to select **3D Colour Management**.
- 2 Press ◀ or ▶ to select **On** or **Off**.

NOTE: When a DVD movie with subtitle is playing back, this mode may not work correctly.

Base Colour Adjustment

The **Base Colour adjustment** feature allows the adjustment of individual colours to suit personal preference. This can be useful when using an external source. It only can be adjusted when **3D Colour management** is set to **On**.

- 1 In the **PICTURE** menu, press **▲** or **▼** to select **Base Colour Adjustment** and press **OK** to enter the submenu.
- 2 Press **▲** or **▼** to select an item you want to adjust and press **OK**.

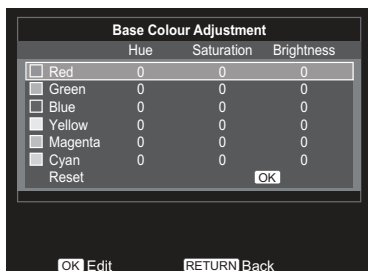

- 3 Press **◀** or **▶** to select **Hue**, **Saturation** or **Brightness**.

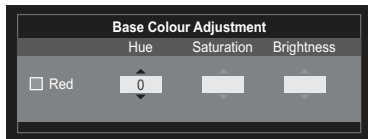

- 4 Press **▲** or **▼** to adjust the settings as required.

NOTE: In the PC Input mode, this function is not available.

MPEG NR – Noise Reduction

When watching a DVD, the compression may cause some words or picture elements to become distorted or pixelated. Using the **MPEG NR** feature reduces this effect by smoothing out the edges.

- 1 In the **PICTURE** menu, press **▲** or **▼** to select **MPEG NR**.
- 2 Press **◀** or **▶** to select **Off**, **Low**, **Middle** or **High**.

Digital Noise Reduction

DNR (Digital Noise Reduction) enables you to “soften” the screen representation of a weak signal to reduce the noise effect.

- 1 In the **PICTURE** menu, press **▲** or **▼** to select **DNR**.
- 2 Press **◀** or **▶** to select **Off**, **Low**, **Middle** or **High**.

NOTE: This function is not available for HDMI input.

Enjoy Photos through USB Port





The Photo Viewer allows you to playback image files from a USB storage device.

Image	Photo	Resolution (Mstat suggest)	Required DRAM size (Mbytes)	Remark
JPEG	Base-line	15360x8704 (1920x8x1088x8)	3.96	Depends on RAM size
	Progressive	1024x768	6.00	
PNG	non-interface	9600x6400	3.66	
	interface	1200x800	3.66	
BMP		9600x6400	3.66	

NOTE:

- Resolution is a reference design, limited only by DRAM (Dynamic Random Access Memory) size and performance
- The larger the resolution, the more memory required
- The smaller the resolution, the less performance required (decrease the time required to display a picture)
- A JPEG decoder is a hardware decoder, with a max resolution of 15360 x 8704
- A PNG/BMP decoder is a software decoder (running on a co-processor), with a max resolution that depends on DRAM size





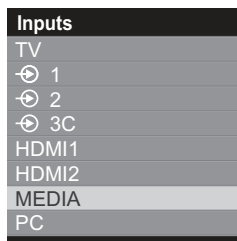

View Photo Files

- 1 Insert a USB storage device and press  on the remote.
Use  or  to select **MEDIA** and press .



- 2 Press  or  to select **PHOTO** and press  to enter the submenu.



- 3 Press , ,  or  to select the folder you wish to view and press  to enter.
Press  or  to page up or down.



- 4 Press ▲, ▼, ◀ or ▶ to select the desired photo and press **OK** to view.
- 5 Press **MENU** to change the settings when viewing a photo.

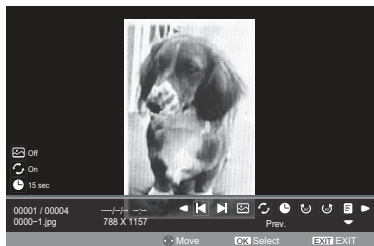

Press ◀ or ▶ to:

- ◀: Go to the previous photo
- ▶: Go to the next photo
- [Slide Show Icon]: Select slide show mode
- [Repeat Icon]: Select repeat mode
- [Interval Time Icon]: Select the desired interval time
- [90° Clockwise Icon]: Clockwise rotation 90°
- [90° Counterclockwise Icon]: Counterclockwise rotation 90°
- [Play List Icon]: Show play list
- [Info Icon]: Photo information

and press **OK** to confirm the setting.

Using Slide Show

This view allows you to watch a slide show of the photos. In this view mode, the only contents it locates on the same directory shall be played.

- 1 Press **MENU** to change the settings when viewing a photo.
- 2 Press ◀ or ▶ to select [Slide Show Icon] and press **OK** to turn **On** or **Off**.

NOTE: Slide Show stops at the last photo in the directory.

Repeat Settings for Slideshow

- 1 Press **MENU** to change the settings when viewing a photo.
- 2 Press ◀ or ▶ to select [Repeat Icon] and press **OK** to turn **On** or **Off**.

Set Interval Time

- 1 Press **MENU** to change the settings when viewing a photo.
- 2 Press ◀ or ▶ to select [Interval Time Icon] and press **OK** to select the desired interval time (3/5/10/15/30/60/90 Sec).

NOTE: If Repeat is On, Slide Show starts photo viewing from the first photo in the folder after reaching the final photo.

Using the Play List

- 1 Press **MENU** to change the settings when viewing a photo.
- 2 Press ◀ or ▶ to select [Play List Icon] and press **OK**.
- 3 Press ▲ or ▼ to select a photo and press **OK** to show the photo. Press **EXIT** on the remote to collapse the list.

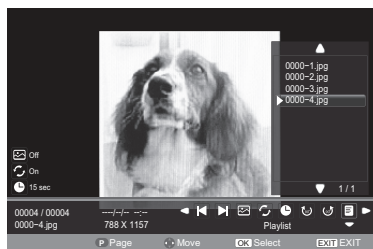
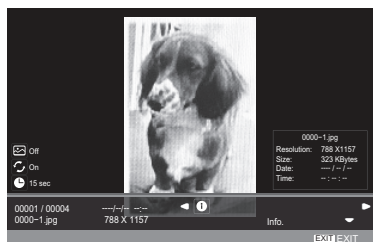

Photo Info

Info displays the file status information (content number, photo title, shooting date and time, resolution etc.).

- 1 Press **MENU** to change the settings when viewing a photo.
- 2 Press ◀ or ▶ to select [Info Icon] and press **OK**.



- 3 The information will be removed by time-out (about 15 sec) or press **OK** to exit.

Enjoy Music through USB Port

The MP3 Player allows you to playback music files from a USB storage device.

Audio Codec	File Extension	Bit Rate	Remark
MPEG1 Layer2	MP3	32Kbps~ 448Kbps(Bit rate) 32KHz ~ 48KHz(Sampling rate)	
MPEG1 Layer3	MP3	32Kbps ~ 320Kbps(Bit rate) 32KHz ~ 48KHz(Sampling rate)	

Play Music Files

- 1 Insert a USB storage device and press on the remote. Use or to select **MEDIA** and press .

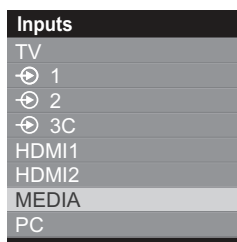

- 2 Press or to select **MUSIC** and press to enter the submenu.



- 3 Press or to select the folder you wish to play and press to enter. Press ^ or v to page up or down.

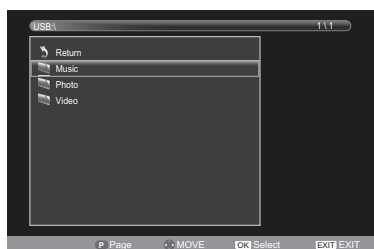

- 4 Press or to select the desired music and press to play.

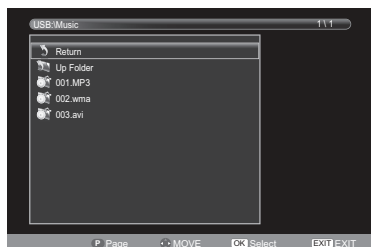

When listening music, press or to:

- : Play or pause the selected music
 - : Rewind the selected music
 - : Fast forward the selected music
 - : Go to the previous music
 - : Go to the next music
 - : Stop play
 - : Select the desired repeat interval:
 - Repeat Off
 - Repeat One: Repeat the selected music once
 - Repeat Folder: Repeat all music files in the selected folder
 - : Show play list
 - : Music information
- and press to confirm the setting.

Repeat Settings

- 1 Press ◀ or ▶ to select .
- 2 Press **OK** to select **Off**, **One** or **Folder**.

Using the Play List

- 1 Press ◀ or ▶ to select  and press **OK**.
- 2 Press ▲ or ▼ to select music and press **OK** to play music.
Press **EXIT** on the remote to collapse the list.

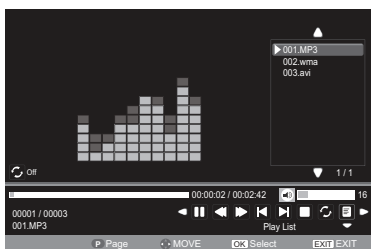

Music Info

Info display file status information (content number, music title, Bit Rate, Artist, Sampling, Year, and size).

- 1 Press ◀ or ▶ to select  and press **OK**.

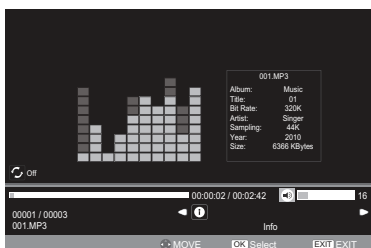

- 2 The information will be removed by time-out (about 15 sec) or press **OK** to exit.

Enjoy Videos through USB Port

The Video Viewer allows you to playback video files from a USB storage device.

File Extension	Container	Video Codec	SPEC	Bit Rate (Mbit/sec)	Profile	Remark
dat, mpg, mpeg	MPG, MPEG	Mpeg1,2	1080P@30fps	20	Main Profile	MP4: GMC is not supported
ts, trp, tp, m2ts	MPEG2-TS H264-TS	MPEG2 ,H.264	1080P@30fps	20	H264: Main Profile and High Profile @Level 4.0 MPEG2: MP@HL	
vob	MPEG2 -PS	MPEG2	1080P@30fps	20	MPEG2: MP@HL	
mp4	AVI, MP4	MPEG4 Xvid 1.00, Xvid 1.01, Xvid 1.02, Xvid 1.03, Xvid 1.10-beta1/2 H.264	1080P@30fps	20	H264: Main Profile and High Profile @Level 4.0 MPEG4: Simple Profile and Advanced Simple Profile @ Level 5	
mkv	MKV	H.264, MPEG1,2,4	1080P@30fps	20	H264: Main Profile and High Profile @ Level 4.0 MPEG4: Simple Profile and Advanced Simple Profile @ Level 5	
avi	AVI(1.0, 2.0), DMF0,1,2	MPEG2, MPEG4 Xvid 1.00, Xvid 1.01, Xvid 1.02, Xvid 1.03, Xvid 1.10-beta1/2 H.264	1080P@30fps	20	MPEG2: MP@HL MPEG4: Simple Profile and Advanced Simple Profile @ Level 5	
Motion JPEG	AVI	JPEG	640x480 @ 30fps	10		

Play Video Files

- 1 Insert a USB storage device and press on the remote. Use or to select **MEDIA** and press .

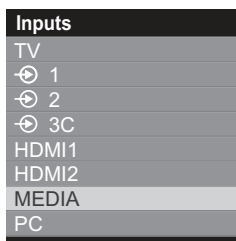

- 2 Press or to select **MOVIE** and press to enter the submenu.



- 3 Press or to select the folder you wish to view and press to enter. Press or to page up or down.

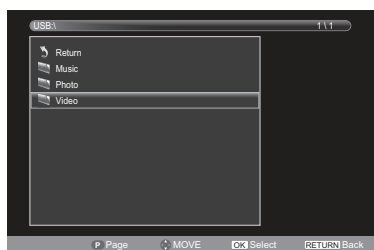

- 4 Press or to select the desired video and press to play.

- 5 Press **MENU** to change the settings when viewing a video.

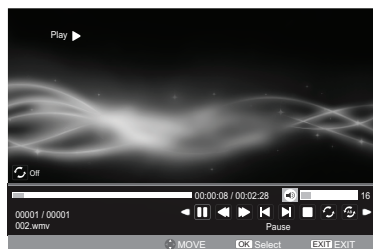

Press or to:

- : Play or pause the selected video
- : Fast back the selected video
- : Fast forward the selected video
- : Go to the previous video
- : Go to the next video
- : Stop play
- : Select the desired repeat interval:
 - Repeat Off
 - Repeat One: Repeat the selected video once
 - Repeat Folder: Repeat all video files in the selected folder
- : Repeat from A to B
 - Set A: A-Set Repeat and Start
 - Set B: B-Set Repeat and repeat from A to B
- : Show play list
- : Video information
- : Slow forward the selected video
- : Step forward the selected video
- : Allows you to input a search time and press to confirm the setting

Repeat Settings

- 1 Press **MENU** to change the settings when playing a video.
- 2 Press **◀** or **▶** to select  and press **OK** to select **Off**, **One** or **Folder**.

Set

- 1 Press **MENU** to change the settings when playing a video.
- 2 Press **◀** or **▶** to select  and press **OK** to select **Set A**, **Set B** or **None**.

Slow Forward

The feature changes forward speeds.

- 1 Press **MENU** to change the settings when playing a video.
- 2 Press **◀** or **▶** to select  and press **OK** to select **SF2X**, **SF4X**, **SF8X**, **SF16X** or **Play**.

Step Forward

The feature allows you to view a video one frame at a time.

- 1 Press **MENU** to change the settings when playing a video.
- 2 Press **◀** or **▶** to select  and press **OK** to play step by step.

Using the Play List

- 1 Press **MENU** to change the settings when playing a video.
- 2 Press **◀** or **▶** to select  and press **OK**.
- 3 Press **▲** or **▼** to select a video and press **OK** to play the video. Press **EXIT** on the remote to collapse the list.

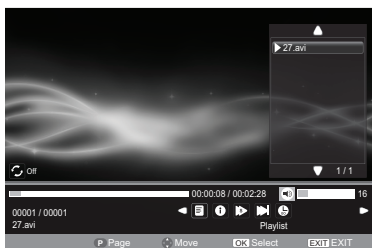

Video Info

Info display file status information (content number, video title, audio track, subtitle, program, size, etc.).

- 1 Press **MENU** to change the settings when playing a video.
- 2 Press **◀** or **▶** to select  and press **OK**.

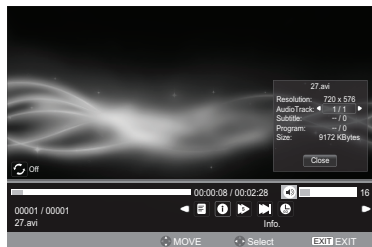

- 3 The information will be removed by time-out (about 15 sec) or press **OK** to exit.

Goto Time

The feature allows you to view a selected time during the video.

- 1 Press **MENU** to change the settings when playing a video.
- 2 Press **◀** or **▶** to select  and press **OK**.
- 3 Use the number key pad on the remote to enter time.

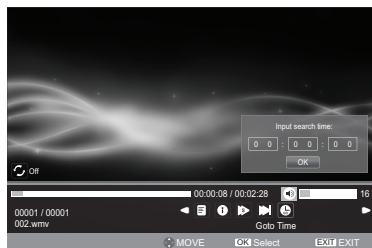

HDMI-LINK Controls

This feature uses **CEC** (Consumer Electronics Control) technology, and allows the control of Toshiba **HDMI-LINK** compatible equipment from the television's remote control.

Note: Not all Toshiba products currently support **HDMI-LINK**.

Equipment Control

The **HDMI-LINK** mode on the television's remote control allows the control of connected **HDMI-LINK** equipment being watched.

To control the **HDMI-LINK** input source, first select the equipment with **HDMI-LINK** input source selection, then switch the mode on the remote control to **HDMI-LINK** and press any buttons.



The available functions are dependent on the equipment connected. Not all the remote control keys may be available. Please refer to the operation manual for each piece of equipment connected.

NOTE: The television features that can be controlled by the connected equipment are: Standby, Volume and Sound Mute.

Input Source Selection

When any equipment using **CEC** technology is connected, the **HDMI-LINK** icon will appear in the input source list allowing selection of individual devices.

Press . A list will appear on screen showing modes and all stored external equipment.

Inputs	
	TV
	1
	2
	3C
	HDMI1
	HDMI2
	MEDIA
	PC

HDMI-LINK Menus

By activating the Enable **HDMI-LINK** feature in the **HDMI-LINK** setup menu, individual **HDMI-LINK** features can then be activated.

One Touch Play

The function of **HDMI-LINK** will automatically power on the television that was in standby mode and switch the television's input source to the port connected with the audio/video equipment by powering-on or playing from the audio/video equipment.

NOTE: This feature is dependent on the connected equipment and television setting.

System Standby

This feature automatically switches the connected equipment into standby when the television goes into standby and conversely for the television to switch into standby when connected equipment goes into standby. It is selected in the **HDMI-LINK** setup menu.

NOTE: This feature is dependent on the connected equipment and television setting.

System Audio Control

Using the **Speaker Preference** feature allows the televisions remote control to adjust the volume or mute the sound of the speakers connected to the television via an AV amplifier.

Ensure that the connected AV amplifier and **HDMI-LINK** equipment are selected in the input source selection and that the **Speaker Preference** is set to **Audio Receiver** in the **HDMI-LINK** setup menu.

NOTE: When the AV Amplifier is switched on, its input source changed or the volume adjusted, the sound will be output from the AV Amplifier's speakers even if TV Speakers has been selected. Turn the television off then on again to output the sound from the TV's speakers.

The full function may not work and is dependent on the Amplifier being used.

Enable HDMI-LINK

When the **Enable HDMI-LINK** is set to **On**, it allows the other functions to be enabled.

- 1 Press **MENU**. Press **◀** or **▶** to select **PREFERENCES** and press **OK** to enter the submenu.



- 2 Press **▲** or **▼** to select **HDMI-LINK Setup**, and press **OK** to enter the submenu.

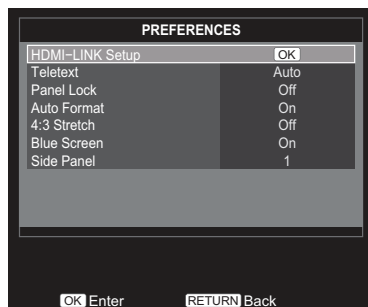

- 3 Press **▲** or **▼** to select **Enable HDMI-LINK**, and press **◀** or **▶** to select **On** or **Off**.

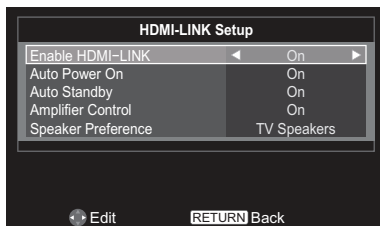

Auto Power On

The **Auto Power On** setting allows the television to be automatically switched **On** or **Off** if a **HDMI-LINK** device is turned **On** or **Off**.

- 1 In the **HDMI-LINK Setup** menu, press **▲** or **▼** to select **Auto Power On**.
- 2 Press **◀** or **▶** to select **On** or **Off**.

Auto Standby

When the **Auto Standby** is enabled, switching off the television will automatically switch off all connected **HDMI-LINK** equipment.

- 1 In the **HDMI-LINK Setup** menu, press ▲ or ▼ to select **Auto Standby**.
- 2 Press ◀ or ▶ to select **On** or **Off**.

Amplifier Control

- 1 In the **HDMI-LINK Setup** menu, press ▲ or ▼ to select **Amplifier Control**.
- 2 Press ◀ or ▶ to select **On** or **Off**.

Speaker Preference

This feature allows the audio output preference to be set to the TV speakers or AV amplifier speakers. The AV Amplifier option lets the television's remote control adjust or mute the volume of the audio.

- 1 In the **HDMI-LINK Setup** menu, press ▲ or ▼ to select **Speaker Preference** when **Amplifier Control** is **On**.
- 2 Press ◀ or ▶ to select **TV Speakers** or **Amplifier**.

NOTE: This function is only available when the TV is connected to audio receivers that support CEC function.

Preference Controls

On Timer

This feature allows you to set the television to turn on automatically to a preset channel at a certain time of day or after a certain length of time. When **On timer** is set to **On**, the green On Timer indicator on the front of the television is lit.

- 1 Press **MENU**. Press ◀ or ▶ to select **APPLICATIONS** and press **OK** to enter the submenu.



- 2 Press ▲ or ▼ to select **On timer** and press **OK** to enter the submenu.

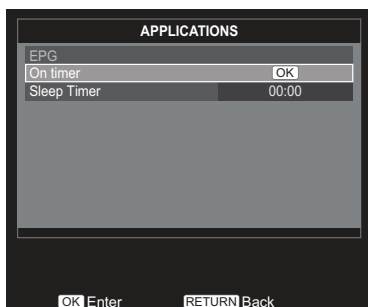

- 3 Press ▲ or ▼ to select **Enable On Timer** and press ◀ or ▶ to select **On** or **Off**.

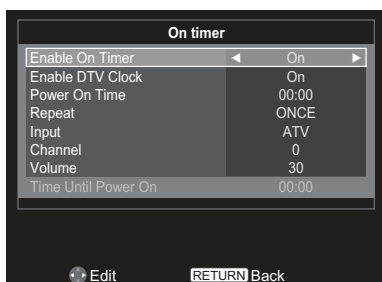

NOTE: The settings are only available when **Enable On Timer** is **On**.

- 4 Press ▲ or ▼ to select **Enable DTV Clock** and press ◀ or ▶ to select **On** or **Off**.

NOTE: **Power On Time** and **Repeat** are only available when **Enable DTV Clock** is **On**.

- 5 Press ▲ or ▼ to select **Power On Time** and press ◀ or ▶ or use the number key pad on the remote to enter the time.

- 6 Press ▲ or ▼ to select **Repeat** and press ◀ or ▶ to select **ONCE**, **DAILY**, **Mon.~Fri.**, **Mon.~Sat.** or **Sat.~Sun.**

- 7 Press ▲ or ▼ to select **Input** and press ◀ or ▶ to select **ATV**, **EXT 1**, **EXT 2**, **EXT 3**, **HDMI 1**, **HDMI 2**, **PC** or **DTV**.

- 8 For DTV, press ▲ or ▼ to select **Channel** and press ◀ or ▶ to change the channel number.

For ATV, press ▲ or ▼ to select **Channel** and press ◀ or ▶ to change the channel number or use the number key pad on the remote to enter the channel number.

NOTE:

- **Channel** is only available when the **Input** is **ATV** or **DTV**.
- Blank screen will appear if not tuned.

- 9 Press ▲ or ▼ to select **Volume** and press ◀ or ▶ to modify the volume, or use the number key pad on the remote to enter the volume.

- 10 Press ▲ or ▼ to select **Time Until Power On** and press ◀ or ▶ or use the number key pad on the remote to enter the time for the TV to turn on automatically.

NOTE: **Time Until Power On** is only available when **Enable DTV Clock** is **Off**.

Sleep Timer

The television can be set to turn itself **Off** after a certain length of time.

- 1 Press **MENU** and press ◀ or ▶ to select **APPLICATIONS**.

- 2 Press ▲ or ▼ to select **Sleep Timer** (Turn off the TV).

- 3 Press ◀ or ▶ to modify the time the TV should turn off, or use the number key pad on the remote to enter the time.

EPG

EPG (Electronic Programme Guide) supports 9 sets of timers. You can set or cancel a timer for a selected programme within the guide. When the TV is on and the timer activates, a dialogue box is shown informing you that the programme is about to start. When the TV is in standby mode and the timer activates, the TV will wake up with backlight off, speaker mute on, and change to the channel selected.

You must set the time correctly before using this function. All set timers are cleared when performing a new channel scan.

- 1 Press **GUIDE** on the remote to display the **Programme Guide**.

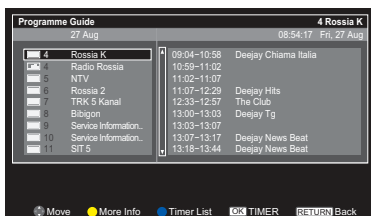

- 2 Press **▲** or **▼** to select the desired channel and press **OK** to enter the programme schedule.
- 3 Press **▲** or **▼** to select the desired programme and press **OK** to enter the **TIMER** menu.

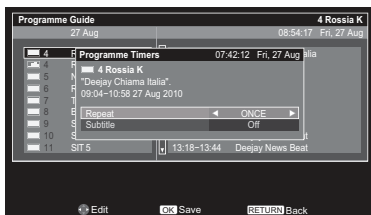

Press **▲** or **▼** to select **Repeat** or **Subtitle** and press **◀** or **▶** to adjust the settings as required.

Press **OK** to save the settings.

- 4 Press the **■** button on the remote to enter the **Timer List** menu.

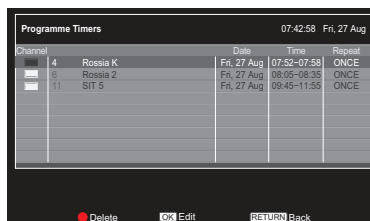

- 5 Press **▲** or **▼** to select the desired programme and press **OK** to edit.

NOTE: Press the **■** button on the remote to delete the timer.

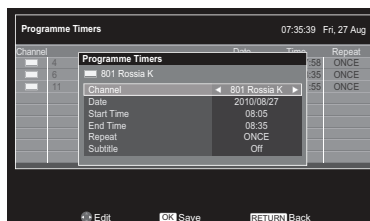

Press **▲** or **▼** to select **Channel**, **Date**, **Start Time**, **End Time**, **Repeat** or **Subtitle** and press **◀** or **▶** to adjust the settings as required.

Press **OK** to save the settings.

NOTE:

- When the timer is set, the Timer LED on the front panel lights on.
- After adjustment, the TV clock may not match the time in the EPG Programme Guide. The EPG Programme Guide time follows the broadcast stream time which can not be adjusted.

Panel Lock

Panel Lock disables the buttons on the television. All buttons on the remote control can still be used.

- 1 Press **MENU**. Press ◀ or ▶ to select **PREFERENCES** and press **OK** to enter the submenu.



- 2 Press ▲ or ▼ to select **Panel Lock** and press ◀ or ▶ to select **On** or **Off**.

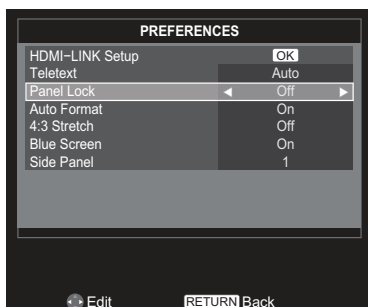

When **Panel Lock** is **On**, a reminder will appear when the buttons on the television are pressed. If the standby button is pressed the television will switch off and can only be brought out of standby by using the remote control.

Auto Format (Widescreen)

When this television receives a true Widescreen picture and Auto format is On, it will automatically be displayed in Widescreen format, irrespective of the television's previous setting.

- 1 In the **PREFERENCES** menu, press ▲ or ▼ to select **Auto Format**.
- 2 Press ◀ or ▶ to select **On** or **Off**.

4:3 Stretch

When **4:3 Stretch** is activated, this function will switch 4:3 format programmes into a full screen picture.

- 1 In the **PREFERENCES** menu, press ▲ or ▼ to select **4:3 Stretch**.
- 2 Press ◀ or ▶ to select **On** or **Off**.

NOTE: In HDMI signal format, this function is available.

Blue Screen

When **Blue Screen** is selected, the screen will turn blue and the sound will be muted when no signal is received.

- 1 In the **PREFERENCES** menu, press ▲ or ▼ to select **Blue Screen**.
- 2 Press ◀ or ▶ to select **On** or **Off**.

NOTE: This function is not available in DTV mode.

Side Panel

The **Side Panel** feature lightens or darkens the band each side of the screen when in 4:3 or 14:9 format. This helps prevent image retention of the band and can also make viewing in bright or dark conditions more comfortable.

- 1 In the **PREFERENCES** menu, press ▲ or ▼ to select **Side Panel**.
- 2 Press ◀ or ▶ to adjust the settings as required.

System Information

In the **SETUP** menu, press ▲ or ▼ to select **System Information** and press **OK** to display the model information and firmware version.

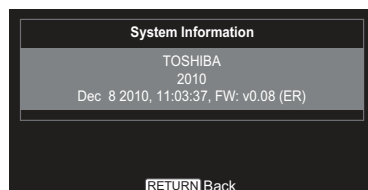

System Upgrade

- 1 Press **MENU**. Press ◀ or ▶ to select **SETUP** and press **OK** to enter the submenu.



- 2 Press ▲ or ▼ to select **System Upgrade** and press **OK** to enter the submenu.

- 3 Press ▲ or ▼ to select **Auto Upgrade** and press ◀ or ▶ to select **On** or **Off**.

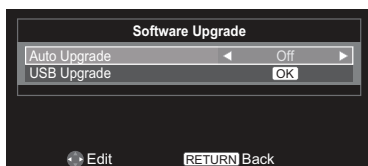

- 4 Insert a USB storage device. Press ▲ or ▼ to select **USB Upgrade** and press **OK** to start upgrading the firmware.

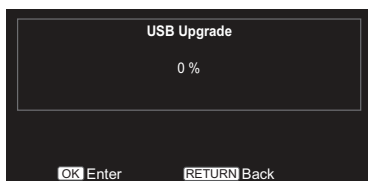

NOTE: Firmware upgrading is suggested to be done by the professional service personnel.

Text Services and Text Information

This television has a multi-page text memory, which takes a few moments to load.

Setting the Modes

- 1** In the **PREFERENCES** menu, press **▲** or **▼** to select **Teletext**.

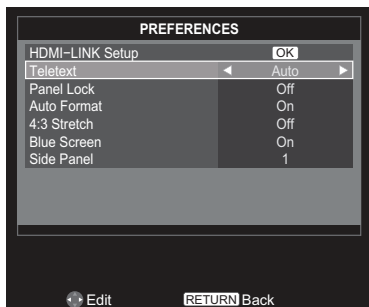

- 2** Press **◀** or **▶** to select **Auto** or **LIST**.

Navigating Pages using Auto

If Fastext is available, four coloured titles will appear at the base of the screen.

To access one of the four given subjects, press the relevant coloured button on the remote control.

For further information on your particular text system(s), see the broadcast text index page or, consult your local Toshiba dealer.

Navigating Pages using LIST

If Fastext is available, four coloured titles with numbers 100, 200, 300 and 400 have been programmed into the television's memory.

To view these pages press the relevant coloured buttons.

To change these stored pages press the relevant coloured button and enter a new 3 digit number. This number will change in the top left of the screen and in the coloured highlight. Press **OK** to store. The bars at the bottom of the screen will flash white. Whenever **OK** is pressed all four page numbers showing at the bottom will be stored and the previous ones will be lost.

If **OK** is not pressed the selection will be forgotten when text is cancelled.

Other pages may be viewed by entering the 3 digit page number – but **DO NOT** press **OK** or these pages will be stored.

Control Buttons

Below is a guide to the functions of the remote control text buttons.

Ⓜ Displays the index/initial page:

Press **Ⓜ** to access the index/initial page. The page displayed is dependant on the broadcaster.

Ⓜ Reveals concealed text:

To discover the solutions on quiz and joke pages press the **Ⓜ** button.

Ⓜ Holds a wanted page:

At times it is convenient to hold a page of text. Press **Ⓜ** and **Ⓜ** will appear in the top left of the screen. The page will be held on-screen until the button is pressed again.

Ⓜ Enlarges the text display size:

Press **Ⓜ** once to enlarge the top half of the page, press again to enlarge the bottom half of the page. Press again to revert to normal size.

Ⓜ Selects a page while viewing a normal picture:

Enter the page number then press **Ⓜ**, a normal picture will be displayed. The television will indicate when the page is present by displaying the page number at the top of the screen.

To display news flashes:

Select the news flash page for the chosen text service (see the index page of your text service).

By pressing **Ⓜ**, news flashes will be displayed as and when they are broadcast. Press **Ⓜ** again to cancel the display.

How to change the page:

Press **▲** or **▼** to change the page.

Press **◀** or **▶** to change the sub page when a sub page is available.

The news flash page must be cancelled before changing channels.

PC Settings

- Most of the picture controls and functions are available. However features not available will be greyed out.
- In the PC input mode, the **Manual Setting** is not displayed.
- First press \odot until the video input mode list appears on the screen, then press \blacktriangle or \blacktriangledown and \odot in order to select the PC input mode.
- This function may not be available for some signal or if no signal is received.
- The optimum points of the clock phase and sampling clock adjustments may be incomprehensible according to the input signals.

Horizontal and Vertical Position

Connect the PC (as shown in the “Connecting a Computer” section) and ensure that a picture is showing on the television screen. The picture position may now be adjusted to suit personal preference.

- 1 Press **MENU**. Press \blacktriangleleft or \blacktriangleright to select **SETUP** and press \odot to enter the submenu.



- 2 Press \blacktriangle or \blacktriangledown to select **PC Setting**, and press \odot to enter the submenu.

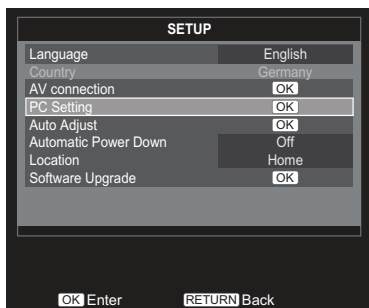

- 3 Press \blacktriangle or \blacktriangledown to select **Horizontal Position** or **Vertical Position** and press \blacktriangleleft or \blacktriangleright to adjust the settings as required.

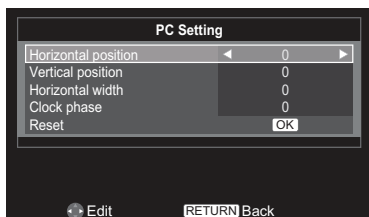

Horizontal Width

- 1 In the **PC Setting** menu, press \blacktriangle or \blacktriangledown to select **Horizontal width**.
- 2 Press \blacktriangleleft or \blacktriangleright to adjust the settings as required.

Clock Phase

The **Clock phase** matches the PC signal with the LCD display.

Adjusting this can clear horizontal stripes and picture blur.

- 1 In the **PC Setting** menu, press \blacktriangle or \blacktriangledown to select **Clock phase**.
- 2 Press \blacktriangleleft or \blacktriangleright to obtain a clear picture.

Reset

This feature resets all PC settings to the factory settings.

Note: If any PC settings have not been changed, **Reset** is not available.

- 1 In the **PC Setting** menu, press \blacktriangle or \blacktriangledown to select **Reset**.
- 2 Press \odot .

NOTE:

- When a PC is connected using HDMI none of these functions will be available.
- The screen is disrupted momentarily when adjusting PC setting. This is not a sign of malfunction.
- The default settings and adjustment ranges may vary depending on the input signal format.

Input Selection and AV Connections

Use the Input Selection feature if the television does not switch over automatically when using an external device.

HDMI1 Audio

If the connected HDMI source does not support digital audio, plug the audio cable into **PC/HDMI 1 (AUDIO)** on the back of the television (as shown in the "Connecting an HDMI or DVI device to the HDMI input" section), then use the HDMI 1 Audio setting.

- 1 Press **MENU**. Press ◀ or ▶ to select **SETUP** and press **OK** to enter the sub-menu.



- 2 Press ▲ or ▼ to select **AV connection**, and press **OK** to enter the sub-menu.

- 3 Press ▲ or ▼ to select **HDMI1 audio**, press ◀ or ▶ to select **Auto**, **Digital** or **Analogue**.

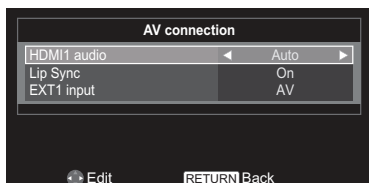

NOTE: The **Lip Sync** function is only available in HDMI mode.

Lip Sync Mode

This option activates an auto audio/video display timing adjustment function that allows HDMI source devices to accurately perform synchronization automatically.

All of the above HDMI settings require a proper HDMI source device.

If HDMI source products do not support these functions, the TV may not work properly when activating these functions.

NOTE:

- In a non-HDMI signal mode, this function is not available.
- In your HDMI connection is capable of 1080p and/or your TV is capable of refresh rates greater than 60Hz or supports Deep Colour, you will need a Category2 cable. Conventional HDMI/DVI cables may not work properly with this mode.

Input Signal Selection

You can select source of **AV** or **S-VIDEO** from this function.

- 1 In the **AV connection** menu, press ▲ or ▼ to select **EXT1 input**.
- 2 Press ◀ or ▶ to select **AV** or **S-VIDEO**.

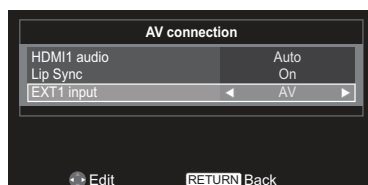

Specifications and Accessories

- This television complies with the specification listed below.
- Design and specifications are subject to change without notice.

DVB-T Broadcast systems/channels		Broadcast systems/channels		Sound Output (At 10% Distortion)	Model 26	5W + 5W	32	5W + 5W	40	7W + 7W	7W + 7W
UK	UHF 21-68	PAL-I	UHF UK21-UK69								
France	VHF 05-10 (VHF 01-05) UHF 21-69	PAL-B/G	UHF E21-E69 VHF E2-E12, S1-S41								
Germany	VHF 05-12 UHF 21-69	SECAM-L	UHF F21-F69 VHF F1-F10, B-Q								
Austria	VHF 05-12 UHF 21-69	SECAM-D/K	UHF R21-R69 VHF R1-R12								
Switzerland	VHF 05-12 UHF 21-69										
Italia	VHF 05-12 (D,E,F,G,H,H1,H2) UHF 21-69										
Spain	UHF 21-69										
Nederlands	VHF 05-12 UHF 21-69										
Sweden	VHF 05-12 UHF 21-69										
Finland	VHF 05-12 UHF 21-69										
Greece	VHF 05-12 UHF 21-69										
Video Input	PAL, SECAM, NTSC 3.58/4.43										
External connections											
EXT2/EXT3	Input	RCA jacks	(EXIT2) Video (EXIT3)/Y, P _R /C _B /P _R /C _R								
EXT1	Input/Output	21-pin SCART	Auto, Mixed, RGB, Composite, S-Video / TV Out								
RGB/PC	Input	D-sub	RGB								
HDMI 1/2	Input	HDMI®									
PC/HDMI1		Phone jacks	Audio L + R								
Audio											
Component		RCA jacks	Audio L + R								
Digital Audio		Output	Coaxial (S/PDIF)								
USB Port	Interface version: USB Class: File system:	USB 2.0 USB Flash Driver FAT32									
Stereo		Nicam 2 Carrier System									
Visible Screen Size (H x V mm) (approx.)	Model	26EL83*B	575.69 x 323.71								
		32AV83*B	697.68 x 392.56								
		32LV83*B	698.40 x 392.85								
		32EL83*B	697.68 x 392.25								
		32HL83*B	698.40 x 392.85								
		40LV83*B	885.60 x 498.15								
		42HL83*B	930.24 x 523.26								
Display	16:9										

Power Consumption		
26EL83*B	Annual power consumption (approx.)	59.7kWh
	On mode power consumption(approx.)	40.9W
	Standby power consumption (approx.)	< 0.3W
	Off mode power consumption (approx.)	< 0.3W

32AV83*B	Annual power consumption (approx.)	100.0kWh
	On mode power consumption(approx.)	68.5W
	Standby power consumption (approx.)	< 0.3W
	Off mode power consumption (approx.)	< 0.3W

32LV83*B	Annual power consumption (approx.)	100.6kWh
	On mode power consumption(approx.)	68.9W
	Standby power consumption (approx.)	< 0.3W
	Off mode power consumption (approx.)	< 0.3W

32EL83*B	Annual power consumption (approx.)	69.1kWh
	On mode power consumption(approx.)	47.3W
	Standby power consumption (approx.)	< 0.3W
	Off mode power consumption (approx.)	< 0.3W

32HL83*B	Annual power consumption (approx.)	73.7kWh
	On mode power consumption(approx.)	50.5W
	Standby power consumption (approx.)	< 0.3W
	Off mode power consumption (approx.)	< 0.3W

40LV83*B	Annual power consumption (approx.)	148.2kWh
	On mode power consumption(approx.)	101.5W
	Standby power consumption (approx.)	< 0.3W
	Off mode power consumption (approx.)	< 0.3W

42HL83*B	Annual power consumption (approx.)	117.5kWh
	On mode power consumption(approx.)	80.5W
	Standby power consumption (approx.)	< 0.3W
	Off mode power consumption (approx.)	< 0.3W

*** Operating 4 hours a day and 365 days a year.**

Dimensions (H x W x D mm) (approx.)	Model	26EL83*B	467 x 643 x 181
		32AV83*B	558 x 786 x 233
		32LV83*B	
		32EL83*B	542 x 770 x 201
		32HL83*B	
		40LV83*B	679 x 977 x 274
		42HL83*B	677 x 1007 x 238

Weight (approx.)	Model	26EL83*B	6.5kg
		32AV83*B	
		32LV83*B	10.0kg
		32EL83*B	
		32HL83*B	
		40LV83*B	16.5kg
		42HL83*B	15.0kg

Headphone Socket R3.5mm stereo

Operating Conditions Temperature: 5°C - 35°C
(41°F - 94°F)
Humidity: 20% - 80%
(non-condensing)

Accessories Remote control
2 batteries
(AAA, IEC R03 1.5V)
Power cord
User Manual



Register your TV online at:
www.toshiba.co.uk/registration

ECO USE:

- energy efficiency reduces power consumption and thus saves money by reducing electricity bills,
- turning the television off at its mains supply, or un-plugging it, will cut energy use to zero for all televisions, and is recommended when the television is not being used for a long time, e.g. when on holiday,
- using the hard off-switch will reduce energy use to near zero (where one is fitted),
- putting the television into standby mode, will reduce energy consumption, but will still draw some power,
- reducing the brightness of the screen will reduce energy use.

Cleaning the screen and cabinet...

Turn off the power, clean the screen and cabinet with a soft, dry cloth. We recommend that you do not use any proprietary polishes or solvents on the screen or cabinet as this may cause damage.

Disposal...**The following information is only for EU-member states:**

Disposal of products The crossed out wheeled dust bin symbol indicates that products must be collected and disposed of separately from household waste. Integrated batteries and accumulators can be disposed of with the product. They will be separated at the recycling centres.



The black bar indicates that the product was placed on the market after August 13, 2005. By participating in separate collection of products and batteries, you will help to assure the proper disposal of products and batteries and thus help to prevent potential negative consequences for the environment and human health. 2002/96/EC

For more detailed information about the collection and recycling programmes available in your country, please contact your local city office or the shop where you purchased the product.

Disposal of batteries and/or accumulators.

The crossed out wheeled dust bin symbol indicates that batteries and/or accumulators must be collected and disposed of separately from household waste.



If the battery or accumulator contains more than the specified values of lead (Pb), mercury (Hg), and/or cadmium (Cd) defined in the Battery Directive (2006/66/EC), then the chemical symbols for lead (Pb), mercury (Hg) and/or cadmium (Cd) will appear below the crossed out wheeled dust bin symbol. By participating in separate collection of batteries, you will help to assure the proper disposal of products and batteries and thus help to prevent potential negative consequences for the environment and human health.

For more detailed information about the collection and recycling programmes available in your country, please contact your local city office or the shop where you purchased the product.



Manufactured under license from Dolby Laboratories.

Dolby and the double-D symbol are trademarks of Dolby Laboratories.

DVB is a registered trademark of the DVB Project

HDMI, the HDMI Logo, and High-Definition Multimedia Interface are trademarks or registered trademarks of HDMI Licensing LLC in the United States and other countries.



Printed on recycled paper. 100% Chlorine free.

© TOSHIBA Television Central Europe Sp. z o.o.
All rights reserved.

Reproduction in whole or part without written permission is strictly prohibited.

TOSHIBA Television Central Europe Sp. z o.o.
ul. Pokoju 1, Biskupice Podgórne, 55-040 Kobierzyce, Poland
Specification is subject to change without notice.