

INSTRUMENT APPROACH CHART-ICAO

VAR 4° W

AERODROME ELEV 1400

THR RWY13 ELEV 1395.5

TWR 118.15(118.8)

ZBDS ORDOS/Ejin Horo

RNAV ILS/DME z RWY31

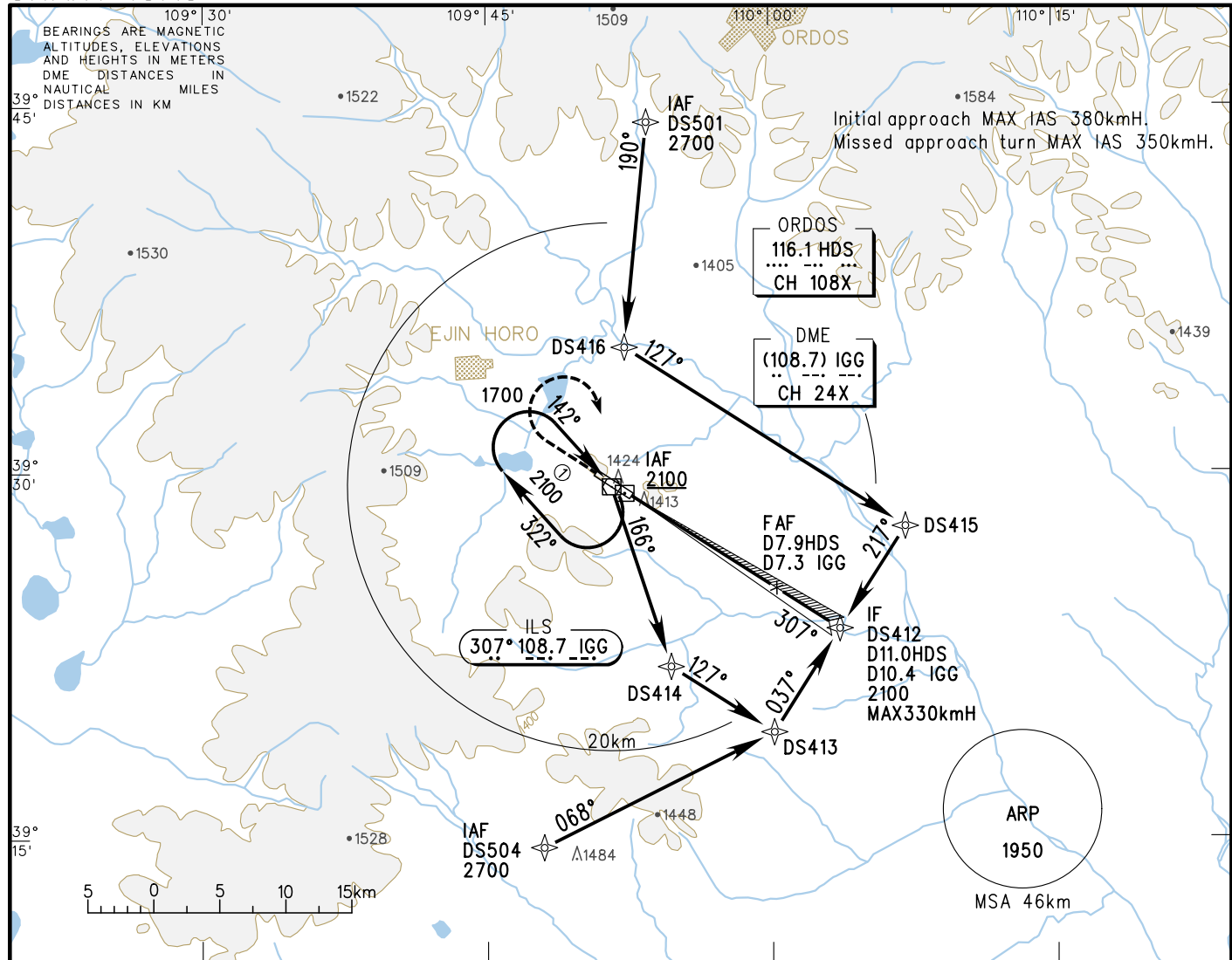

GP INOP	DME (HDS) (NM)	2	3	4	5	6	7	8
	ALT (m)		1529	1625	1723	1820	1917	2014

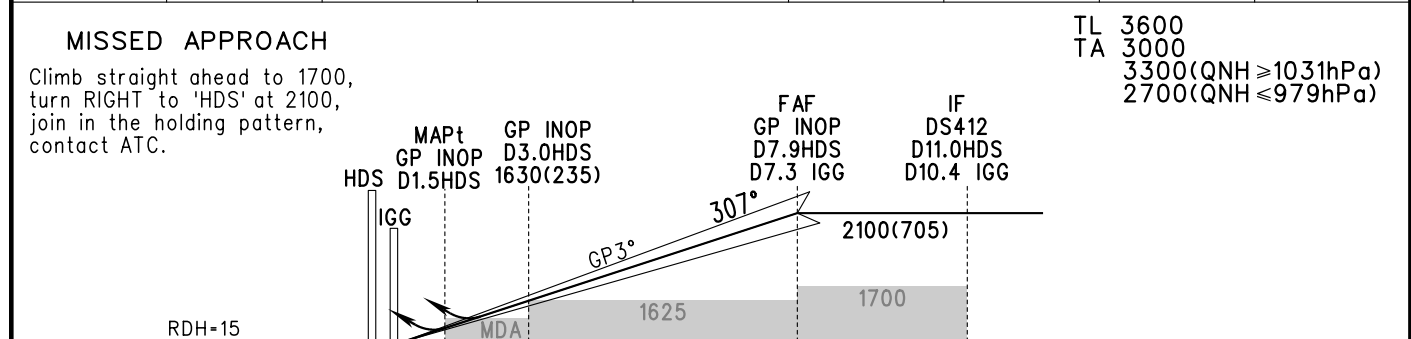

	A	B	C	D	FAF-MAPt(GP INOP) 11.8km						
					GS in kt	80	100	120	140	160	180
ILS/DME DA(H) RVR/VIS	1466(70) 550/800	1471(75) 550/800	1476(80) 550/800		80	100	120	140	160	180	
GP INOP MDA(H) VIS	1528(133) 1700				min:sec	4:47	3:49	3:11	2:44	2:23	2:07
CIRCLING MDA(H) VIS	1636(236) 3800	1670(270) 3800	1670(270) 4000		Rate of descent m/s	2.2	2.7	3.2	3.8	4.3	4.9

Changes: New chart.